

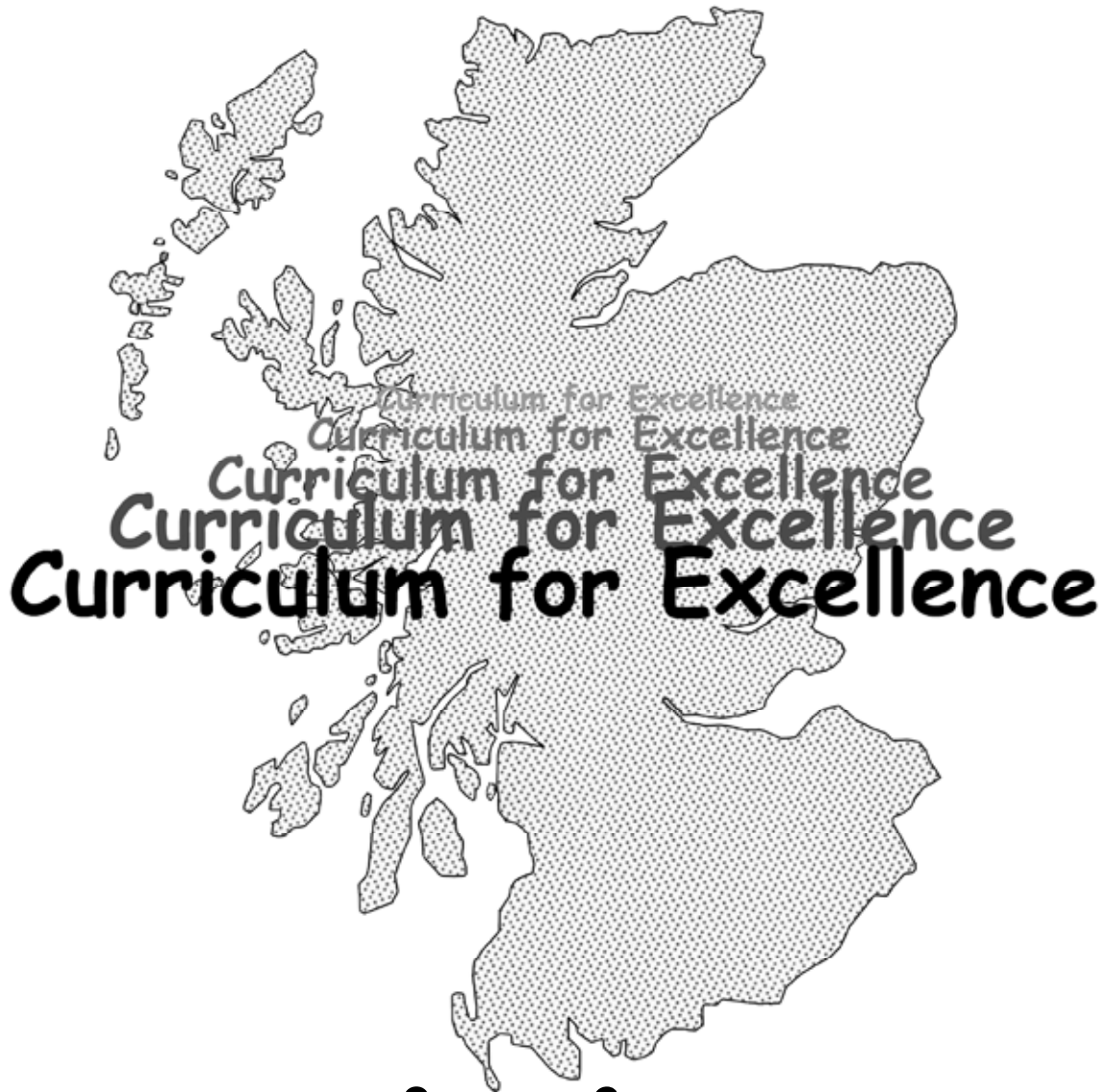

TeeJay  
Publishers

# Book 1b



# Worksheets

1. What does the 6 stand for in :-

a 165

b 1206

c 693

d 6097

2. Write the following numbers using **digits** :-

a one hundred and thirty four

b one thousand four hundred and sixty nine

c three thousand eight hundred and seventy two

d five thousand three hundred and fifty six

e nine thousand five hundred and thirty eight

f six thousand nine hundred and ten

g four thousand seven hundred

h seven thousand and ninety nine

i one thousand one hundred and one

3. Write these numbers using **words** :-

a 482

b 697

c 2114

d 9330

e 5666

Show this to your teacher, then go to page 2 Exercise 1

1. Write the number that comes :-

a 10 after 190

b 100 after 2300

c 20 after 780

d 50 after 3450

e 200 after 1800

f 1000 after 6300

2. Write the number that comes :-

a 10 before 310

b 100 before 5200

c 20 before 610

d 50 before 6150

e 300 before 5200

f 2000 before 7100

3. Put each of these groups of numbers in the correct order.

Start with the **lowest**.

a 698, 702, 689

b 278, 308, 380, 280

c 2987, 2978, 2897, 2888

d 1756, 1876, 1777, 1798, 1808

4. Put each of these groups of numbers in the correct order.

Start with the **highest**.

a 938, 899, 983

b 598, 618, 680, 589

c 4376, 4763, 4736, 4637

d 2098, 2108, 2801, 2189, 2089

**Continued on next sheet**

5. To what numbers are the arrows pointing ?

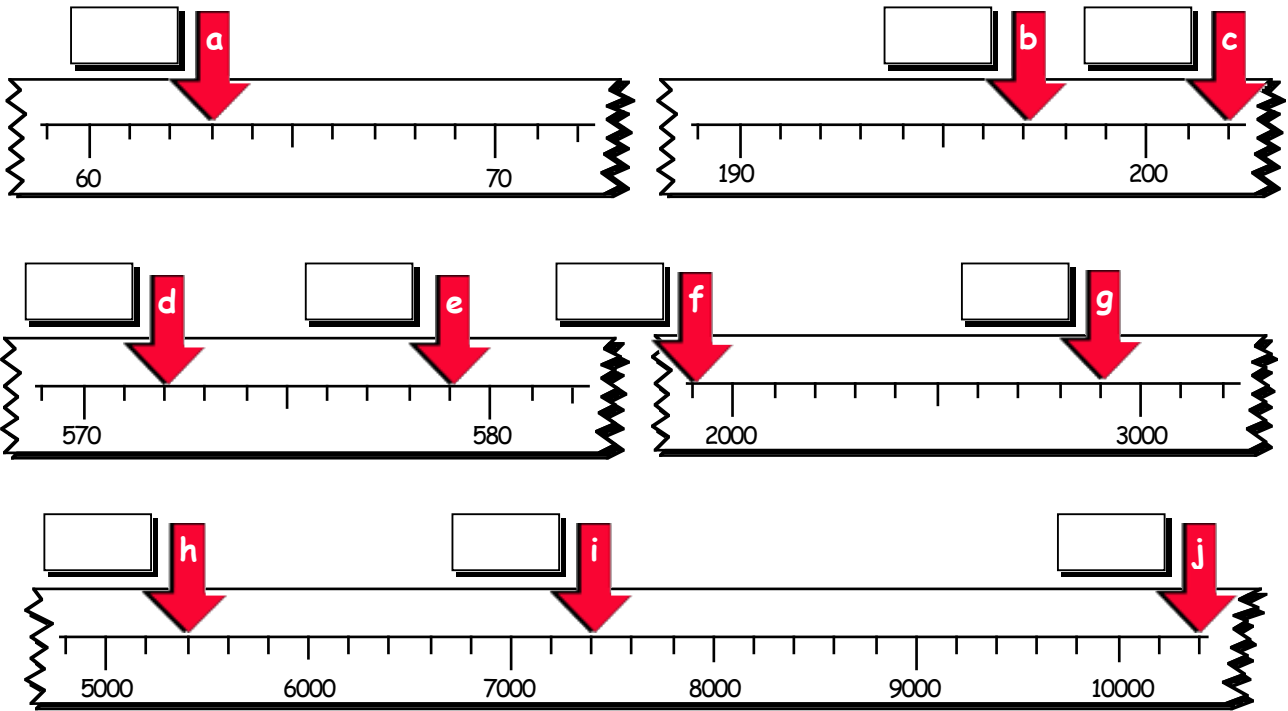

6. To what numbers are the arrows pointing ?

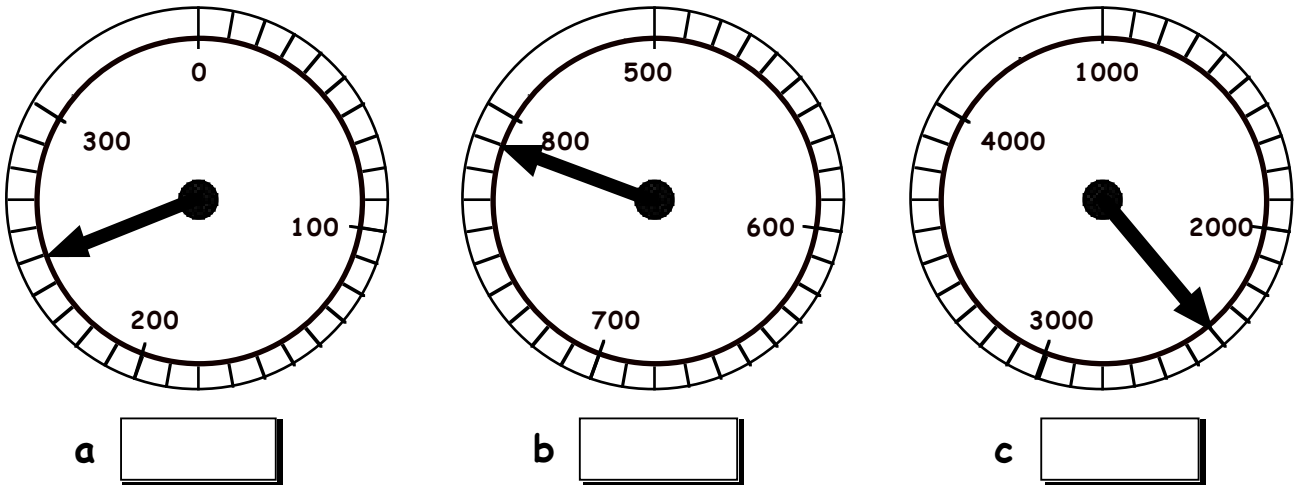

7. How heavy are the 2 animals ?

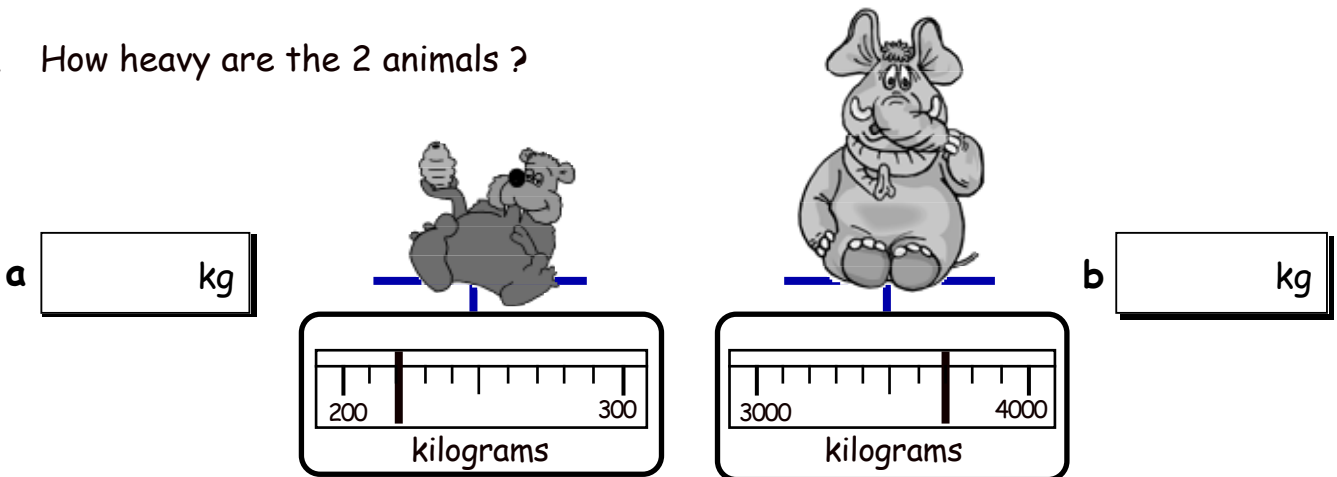

Show this to your teacher, then go to page 3, Question 5

1. Use the scales below to **round** the arrowed numbers to the nearest **ten**.  
Answer in the boxes.

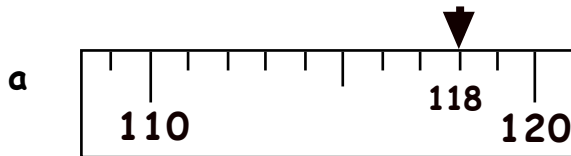

120

(118 is nearer to 120 than it is to 110)

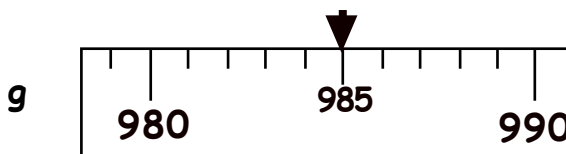
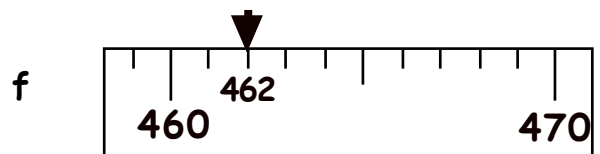
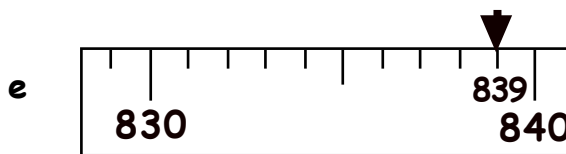
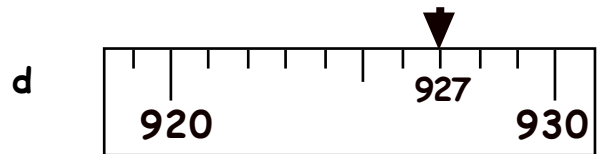
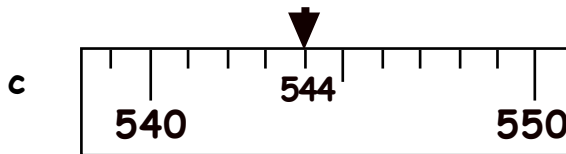
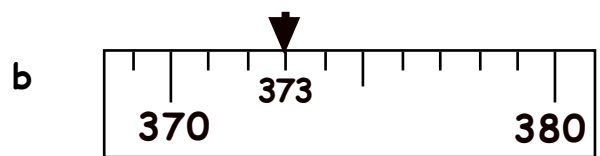

2. Round each number to the nearest 10.

a 118 →

b 323 →

c 629 →

d 945 →

e 254 →

f 757 →

g 569 →

h 874 →

i 496 →

j 1092 →

k 2324 →

l 5097 →

Show this to your teacher, then go to page 4, Exercise 2

Estimate the answers to these using **rounding** to the nearest 10 :-

1.  $117 + 129$  is about the same as  $120 + 130$  which is about  $250$
2.  $139 + 238$  is about the same as  $\quad + \quad$  which is about  $\quad$
3.  $212 + 157$  is about the same as  $\quad + \quad$  which is about  $\quad$
4.  $514 + 96$  is about the same as  $\quad + \quad$  which is about  $\quad$
5.  $338 + 296$  is about the same as  $\quad + \quad$  which is about  $\quad$
6.  $429 + 161$  is about the same as  $\quad + \quad$  which is about  $\quad$
7.  $627 + 233$  is about the same as  $\quad + \quad$  which is about  $\quad$
8.  $718 + 153$  is about the same as  $\quad + \quad$  which is about  $\quad$
9.  $829 + 138$  is about the same as  $\quad + \quad$  which is about  $\quad$
10.  $609 + 324$  is about the same as  $\quad + \quad$  which is about  $\quad$
11.  $468 - 133$  is about the same as  $470 - 130$  which is about  $\quad$
12.  $562 - 115$  is about the same as  $\quad - \quad$  which is about  $\quad$
13.  $879 - 259$  is about the same as  $\quad - \quad$  which is about  $\quad$
14.  $991 - 749$  is about the same as  $\quad$  which is about  $\quad$
15.  $653 - 629$  is about the same as  $\quad$  which is about  $\quad$
16.  $837 - 29$  is about the same as  $\quad$  which is about  $\quad$

Show this to your teacher, then go to page 6 Exercise 3

1. Shade or colour the shapes that have **symmetry**.

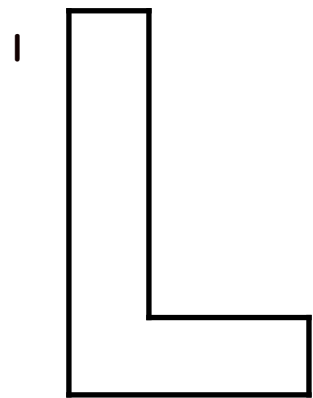
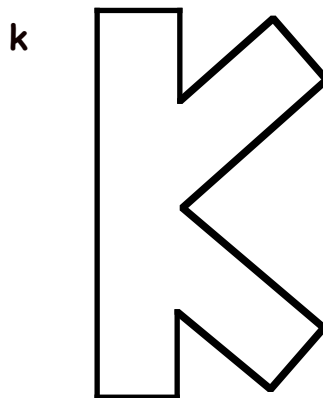
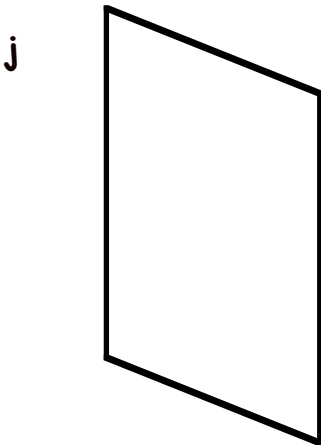
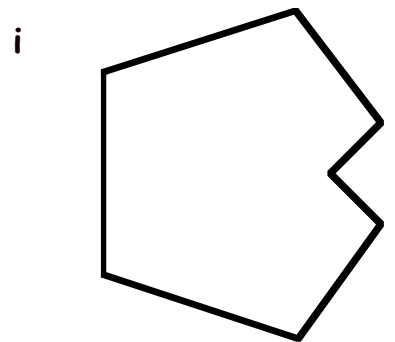
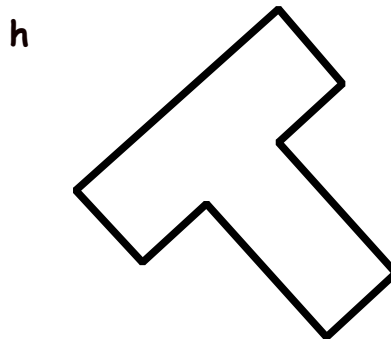
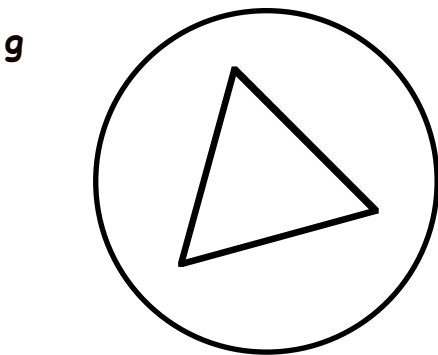
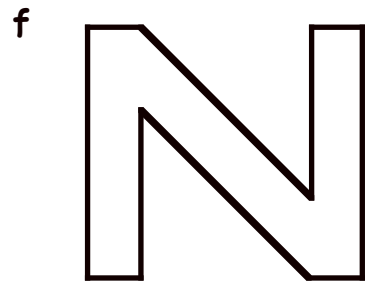
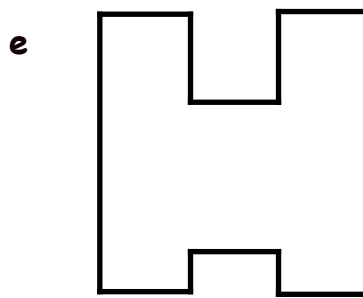
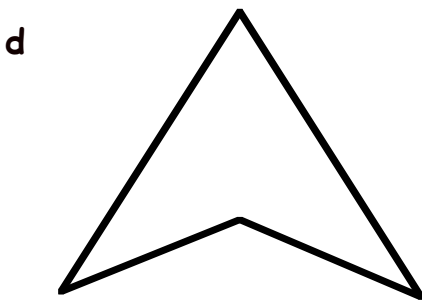
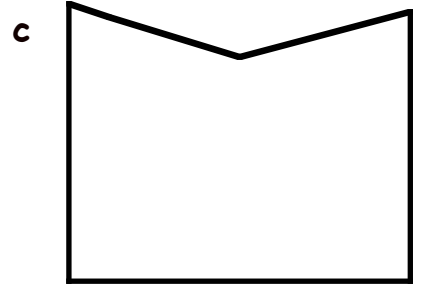
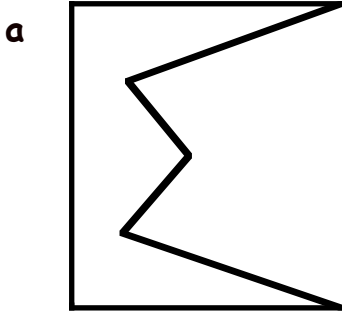

Show this to your teacher, then go to page 10 Exercise 1

1. Use a coloured pencil to draw in all the lines of symmetry.

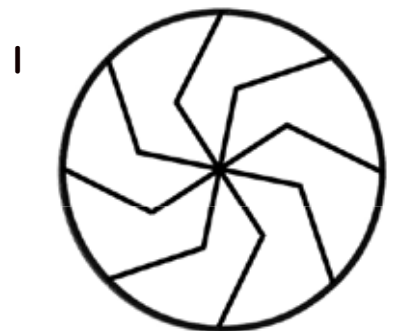
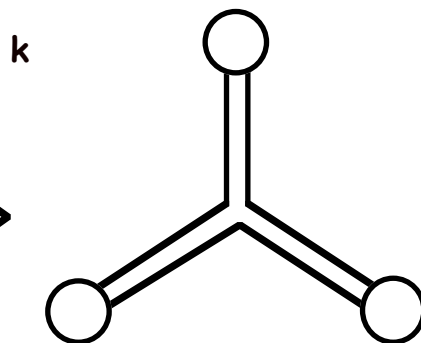
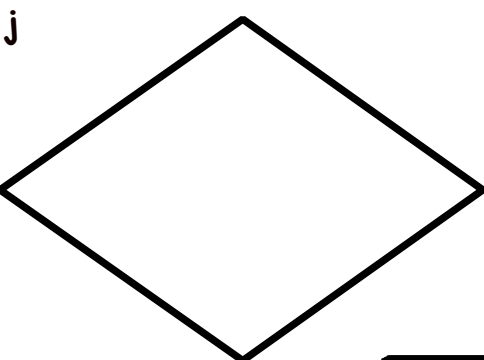
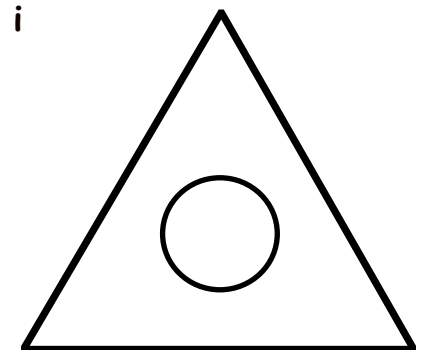
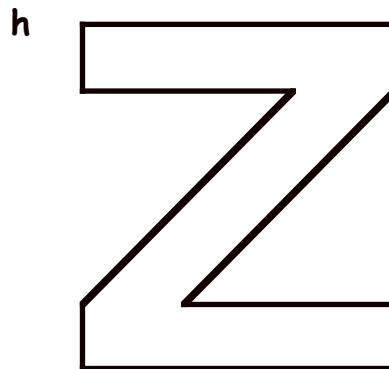
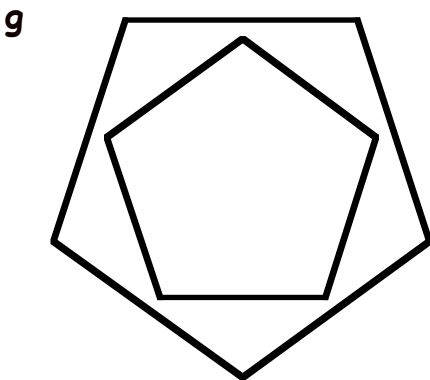
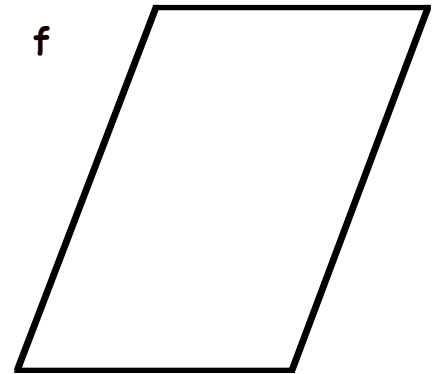
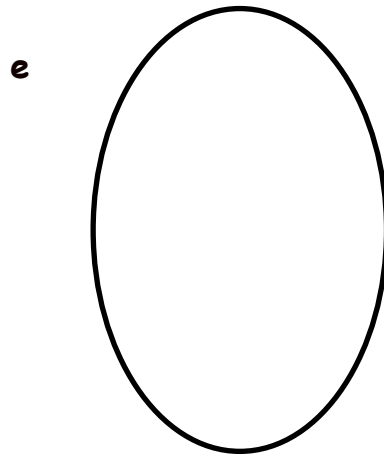
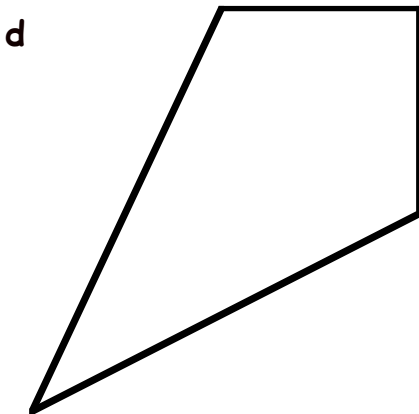
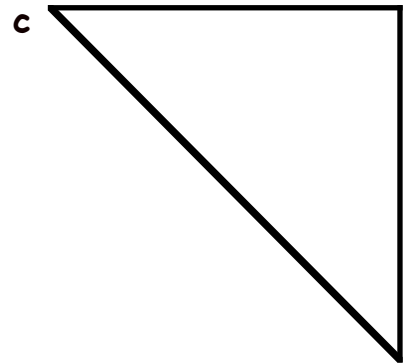
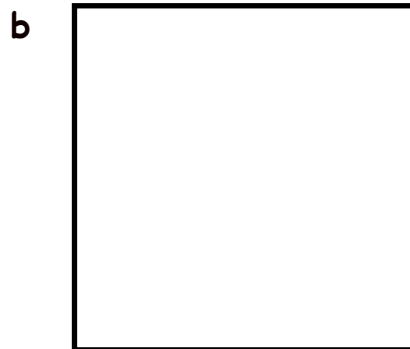
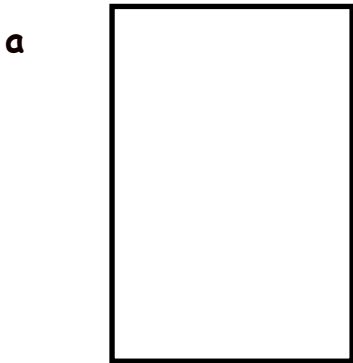

Show this to your teacher, then go to page 11 Question 2



1. Write down **how many** lines of symmetry each of these shapes has.  
Draw the lines of symmetry using a coloured pencil.

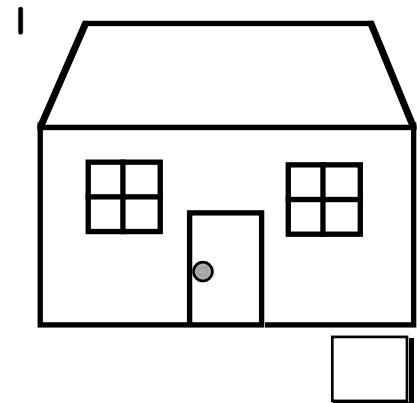
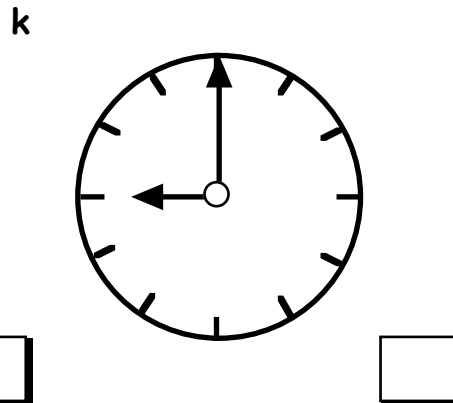
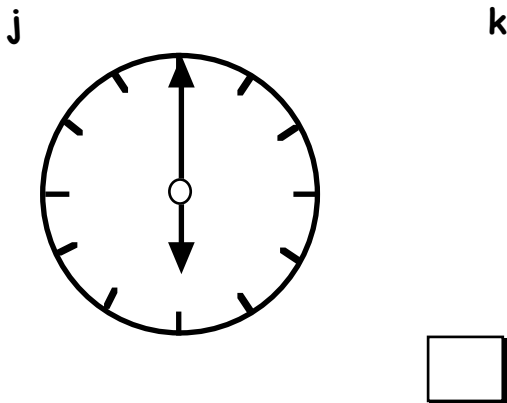
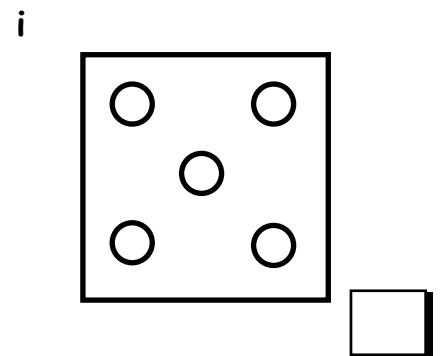
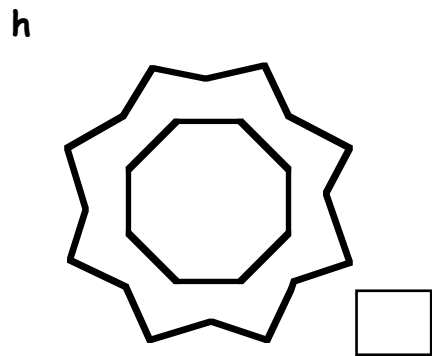
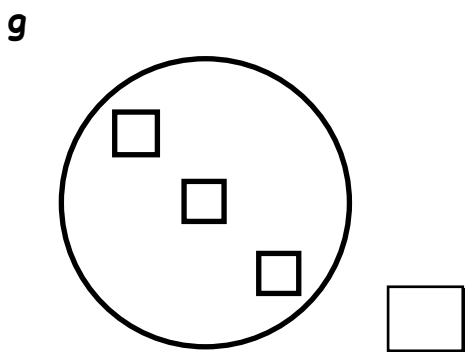
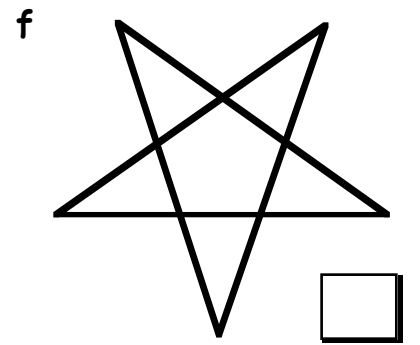
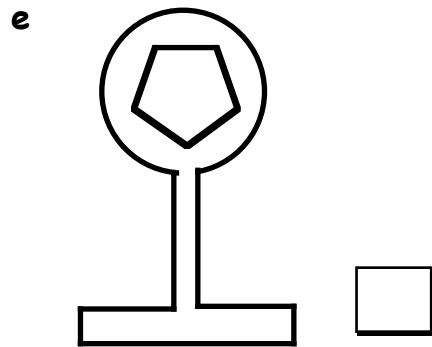
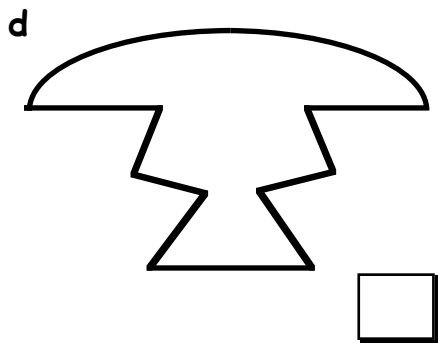
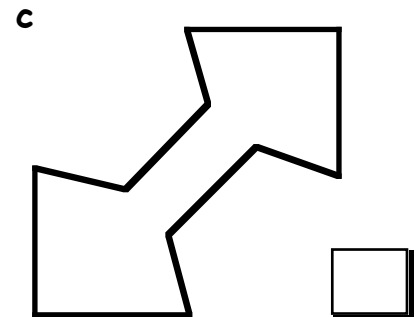
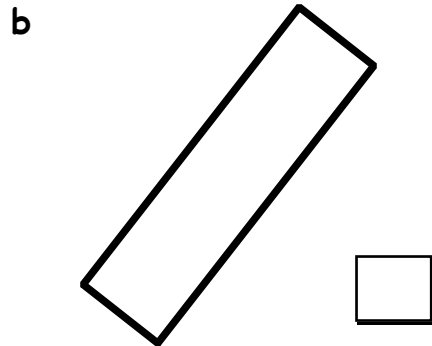
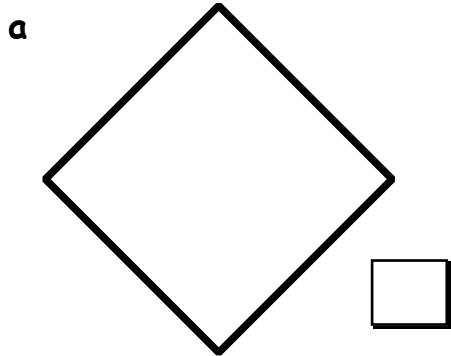

Show this to your teacher, then go to page 13 Question 4

1. Draw the other half of each shape so that the shape has symmetry.

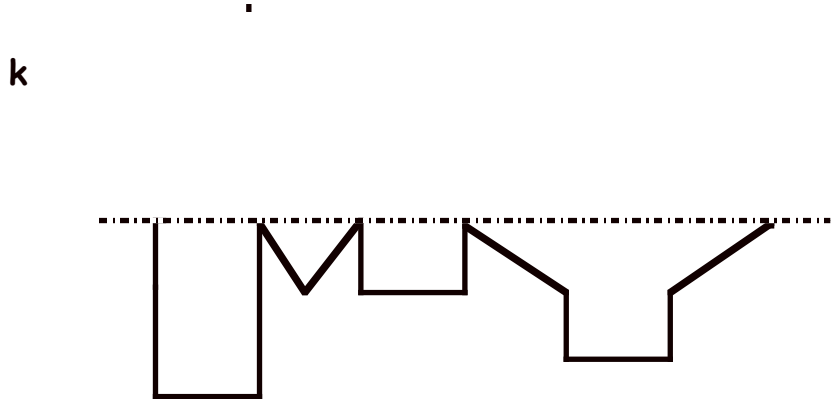
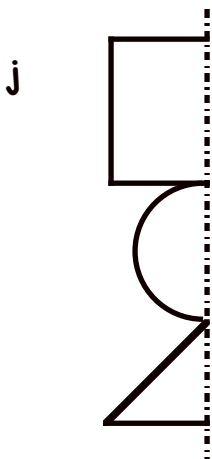
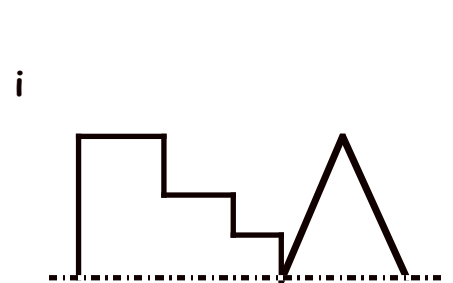
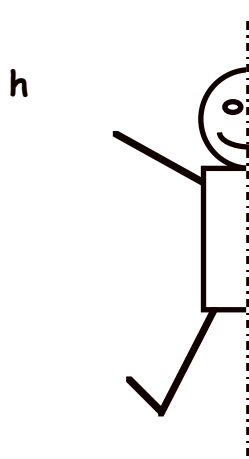
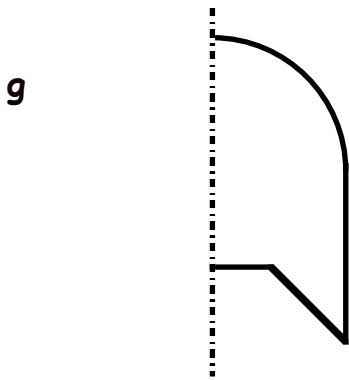
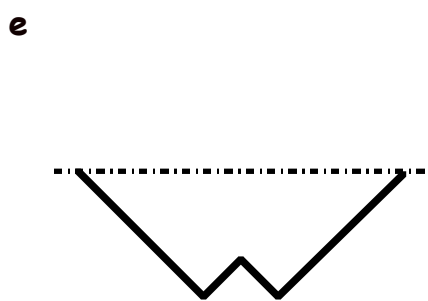
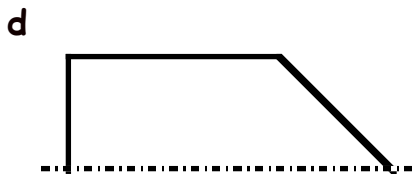
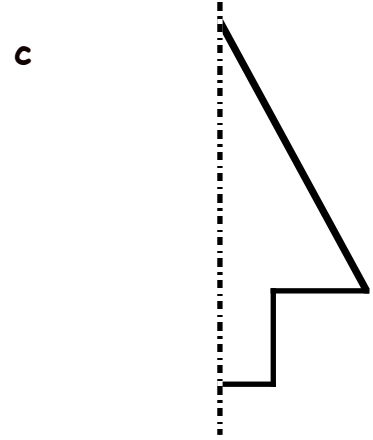
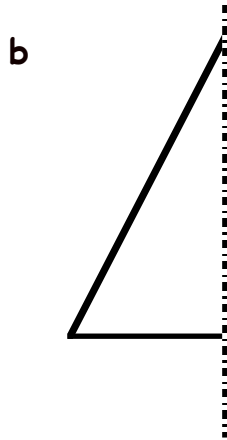
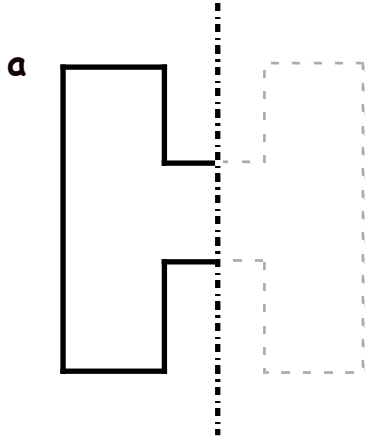

continued on the next page ->

2. Draw the other half of each shape so that the shape has symmetry.

a

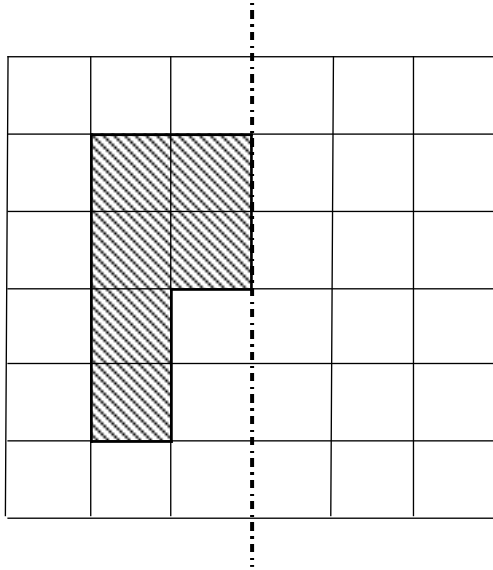

b

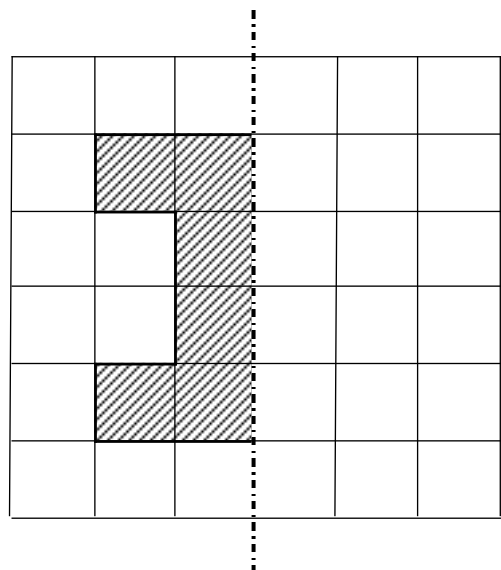

c

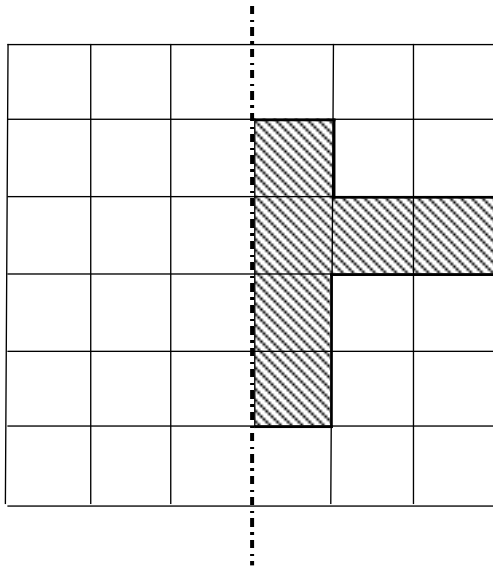

d

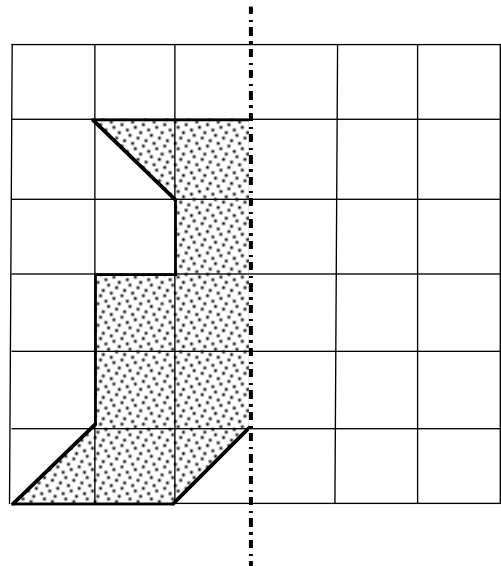

e

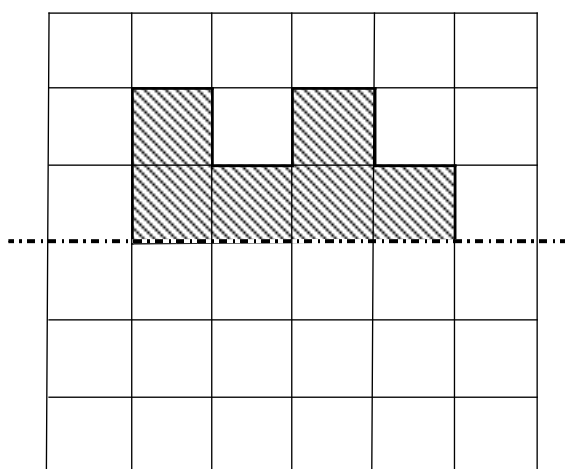

f

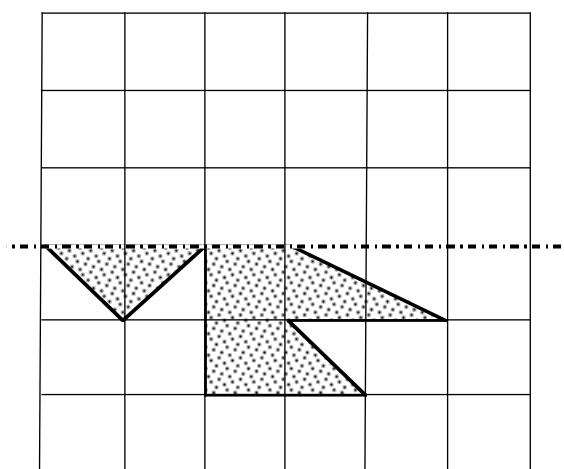

Show this to your teacher, then go to page 15 Exercise 2

1. Complete each shape so that the dotted line becomes a line of symmetry :-

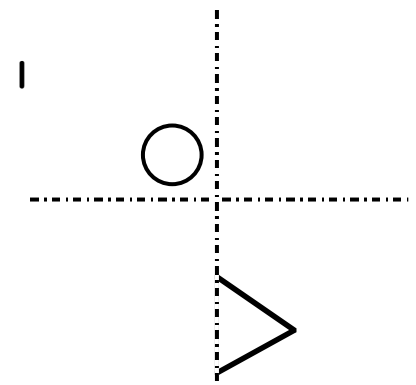
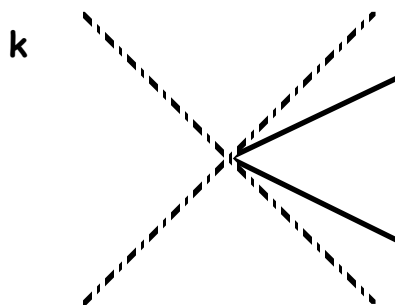
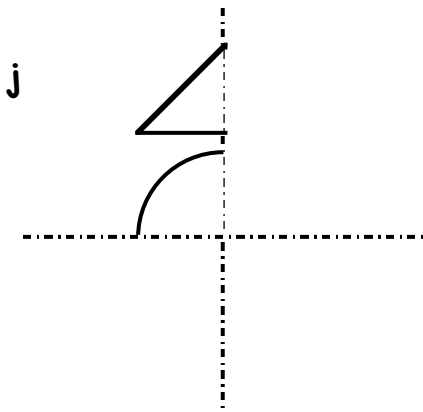
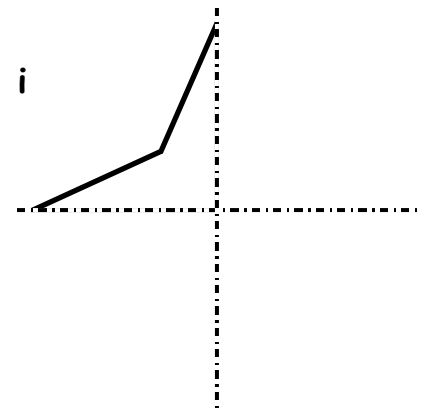
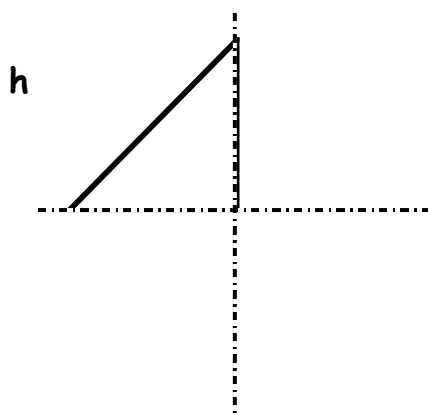
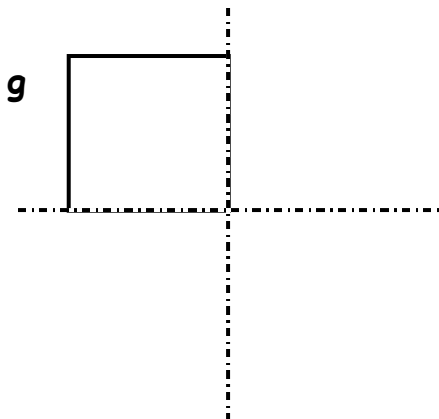
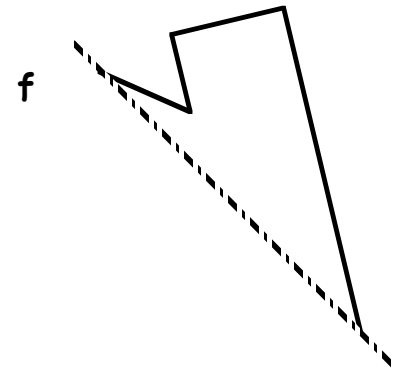
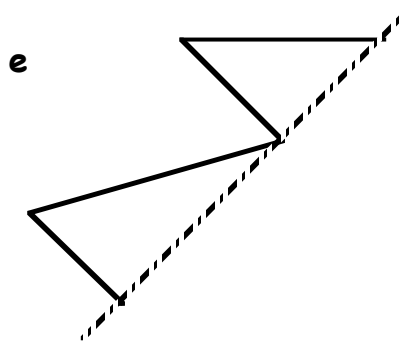
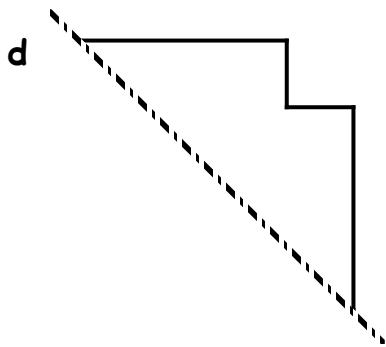
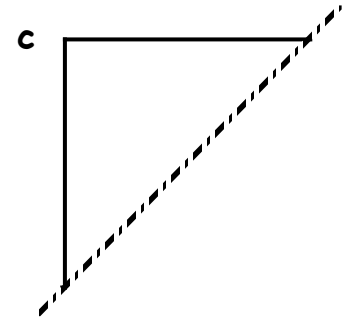
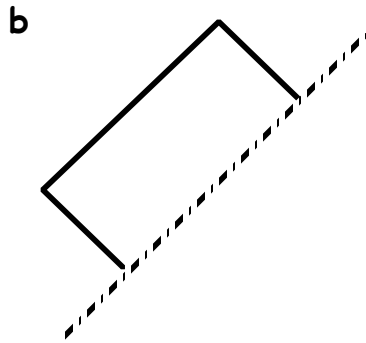
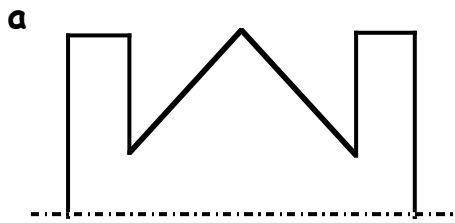

Show this to your teacher, then go to page 17 Question 3

## The 4 times table

Complete the 4 times table :-

$$4 \text{ sets of } 0 = 0$$

$$4 \text{ sets of } 1 = 4$$

$$4 \text{ sets of } 2 = 8$$

$$4 \text{ sets of } 3 = 12$$

$$4 \text{ sets of } 4 = \dots$$

$$4 \text{ sets of } \dots = \dots$$

$$4 \text{ sets of } \dots = \dots$$

$$4 \text{ sets of } \dots = \dots$$

$$4 \text{ sets of } \dots = \dots$$

$$4 \text{ sets of } \dots = \dots$$

$$4 \text{ sets of } \dots = \dots$$

$$4 \times 0 = 0$$

$$4 \times 1 = 4$$

$$4 \times 2 = 8$$

$$4 \times 3 = \dots$$

$$4 \times 4 = \dots$$

$$4 \times 5 = \dots$$

$$4 \times 6 = \dots$$

$$4 \times 7 = \dots$$

$$4 \times \dots = \dots$$

$$4 \times \dots = \dots$$

$$4 \dots \dots = \dots$$

**LEARN**

Memorise the 4 times table, go to Page 21 Questions 1 & 2 then go to the next sheet

Complete these multiplications :-

1     16  
   x 4  
-----

2     48  
   x 4  
-----

3     59  
   x 4  
-----

4     34  
   x 4  
-----

5     20  
   x 4  
-----

6     41  
   x 4  
-----

7     49  
   x 4  
-----

8     32  
   x 4  
-----

9     61  
   x 4  
-----

10    38  
   x 4  
-----

11    24  
   x 4  
-----

12    66  
   x 4  
-----

13    30  
   x 4  
-----

14    43  
   x 4  
-----

15    68  
   x 4  
-----

16    64  
   x 4  
-----

17    52  
   x 4  
-----

18    36  
   x 4  
-----

19    25  
   x 4  
-----

20    81  
   x 4  
-----

21    190  
   x 4  
-----

Show this to your teacher, then go to page 22 Question 3

## The 5 times table

Complete the 5 times table :-

$5 \text{ sets of } 0 = 0$

$5 \text{ sets of } 1 = 5$

$5 \text{ sets of } 2 = 10$

$5 \text{ sets of } 3 = 15$

$5 \text{ sets of } 4 = 20$

$5 \text{ sets of } \dots = \dots$

$5 \text{ sets of } \dots = \dots$

$5 \text{ sets of } \dots = \dots$

$5 \text{ sets of } \dots = \dots$

$5 \text{ sets of } \dots = \dots$

$5 \text{ sets of } \dots = \dots$

$5 \times 0 = 0$

$5 \times 1 = 5$

$5 \times 2 = 10$

$5 \times 3 = 15$

$5 \times 4 = \dots$

$5 \times 5 = \dots$

$5 \times 6 = \dots$

$5 \times 7 = \dots$

$5 \times \dots = \dots$

$5 \times \dots = \dots$

$5 \dots \dots = \dots$

**LEARN**

Memorise the 5 times table, go to Page 21 Questions 1 & 2 then go to the next sheet

Complete these multiplications :-

1      14  
    x 5  
            
    □

2      46  
    x 5  
            
    □

3      57  
    x 5  
            
    □

4      32  
    x 5  
            
    □

5      18  
    x 5  
            
    □

6      39  
    x 5  
            
    □

7      47  
    x 5  
            
    □

8      30  
    x 5  
            
    □

9      59  
    x 5  
            
    □

10     36  
    x 5  
            
    □

11     22  
    x 5  
            
    □

12     64  
    x 5  
            
    □

13     28  
    x 5  
            
    □

14     41  
    x 5  
            
    □

15     66  
    x 5  
            
    □

16     62  
    x 5  
            
    □

17     50  
    x 5  
            
    □

18     34  
    x 5  
            
    □

19     23  
    x 5  
            
    □

20     79  
    x 5  
            
    □

21     188  
    x 5  
            
    □

Show this to your teacher, then go to page 24 Question 3



## The 10 times table

Complete the 10 times table :-

$$10 \text{ sets of } 0 = 0$$

$$10 \text{ sets of } 1 = 10$$

$$10 \text{ sets of } 2 = 20$$

$$10 \text{ sets of } 3 = 30$$

$$10 \text{ sets of } 4 = 40$$

$$10 \text{ sets of } .. = ..$$

$$10 \text{ sets of } .. = ..$$

$$10 \text{ sets of } .. = ..$$

$$10 \text{ sets of } .. = ..$$

$$10 \text{ sets of } .. = ..$$

$$10 \text{ sets of } .. = ..$$

$$10 \times 0 = 0$$

$$10 \times 1 = 10$$

$$10 \times 2 = 20$$

$$10 \times 3 = ..$$

$$10 \times 4 = ..$$

$$10 \times 5 = ..$$

$$10 \times 6 = ..$$

$$10 \times 7 = ..$$

$$10 \times .. = ..$$

$$10 \times .. = ..$$

$$10 .. .. = ..$$

**LEARN**

Memorise the 10 times table, go to Page 21 Questions 1 & 2 then go to the next sheet

Complete these multiplications :-

$$\begin{array}{r} 1 \quad 17 \\ \times 10 \\ \hline \end{array}$$

$$\begin{array}{r} 2 \quad 24 \\ \times 10 \\ \hline \end{array}$$

$$\begin{array}{r} 3 \quad 32 \\ \times 10 \\ \hline \end{array}$$

$$\begin{array}{r} 4 \quad 38 \\ \times 10 \\ \hline \end{array}$$

$$\begin{array}{r} 5 \quad 45 \\ \times 10 \\ \hline \end{array}$$

$$\begin{array}{r} 6 \quad 49 \\ \times 10 \\ \hline \end{array}$$

$$\begin{array}{r} 7 \quad 60 \\ \times 10 \\ \hline \end{array}$$

$$\begin{array}{r} 8 \quad 63 \\ \times 10 \\ \hline \end{array}$$

$$\begin{array}{r} 9 \quad 67 \\ \times 10 \\ \hline \end{array}$$

$$\begin{array}{r} 10 \quad 74 \\ \times 10 \\ \hline \end{array}$$

$$\begin{array}{r} 11 \quad 79 \\ \times 10 \\ \hline \end{array}$$

$$\begin{array}{r} 12 \quad 81 \\ \times 10 \\ \hline \end{array}$$

$$\begin{array}{r} 13 \quad 90 \\ \times 10 \\ \hline \end{array}$$

$$\begin{array}{r} 14 \quad 14 \\ \times 10 \\ \hline \end{array}$$

$$\begin{array}{r} 15 \quad 76 \\ \times 10 \\ \hline \end{array}$$

$$\begin{array}{r} 16 \quad 108 \\ \times 10 \\ \hline \end{array}$$

$$\begin{array}{r} 17 \quad 194 \\ \times 10 \\ \hline \end{array}$$

$$\begin{array}{r} 18 \quad 175 \\ \times 10 \\ \hline \end{array}$$

$$\begin{array}{r} 19 \quad 236 \\ \times 10 \\ \hline \end{array}$$

$$\begin{array}{r} 20 \quad 440 \\ \times 10 \\ \hline \end{array}$$

$$\begin{array}{r} 21 \quad 538 \\ \times 10 \\ \hline \end{array}$$

Show this to your teacher.

1. Write each time in words. The first one has been done for you.

a **5:30**

half past 5.

b **8:30**

c **3:00**

d **6:45**

e **4:15**

f **7:45**

2. Fill in the digital time shown on the clock faces.

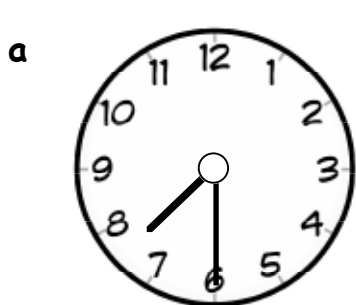

:

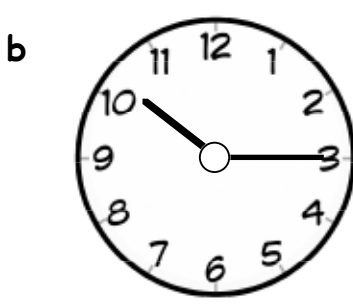

:

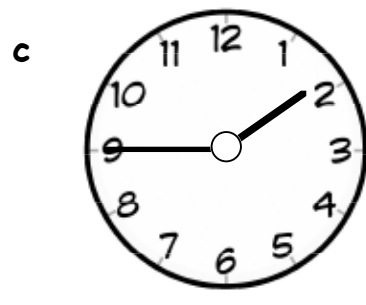

:

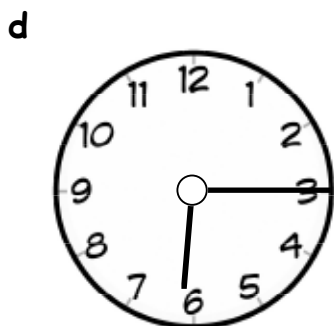

:

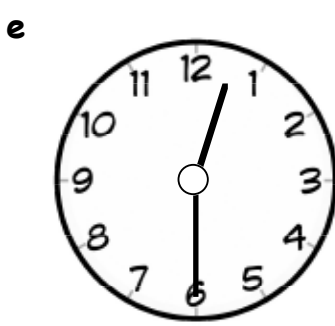

:

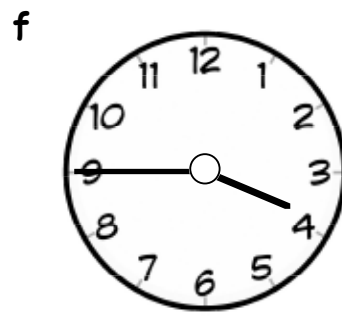

:

**Show this to your teacher, then go to page 34 Exercise 1**

1. Write each time on the digital clocks :-

a quarter to 3

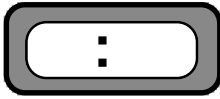

b quarter past 2

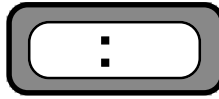

c half past 8

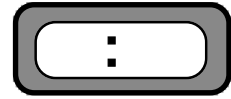

d quarter past 7

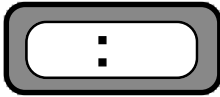

e twenty past 11

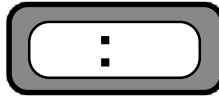

f ten to 5

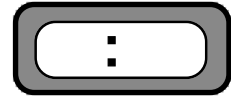

g ten past 12

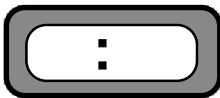

h twenty five to 7

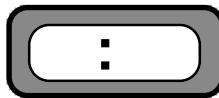

i five past 6

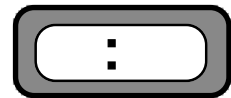

2. Fill in the digital time shown on the clock faces :-

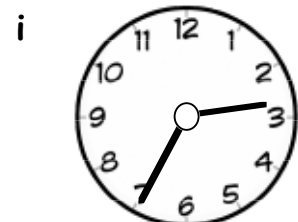
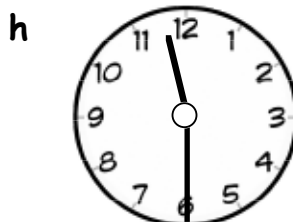
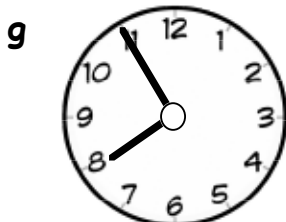
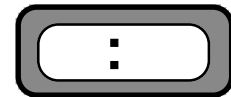
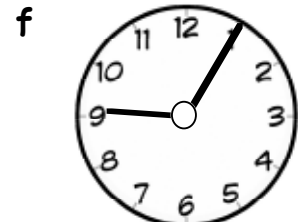
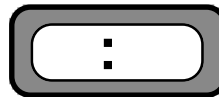
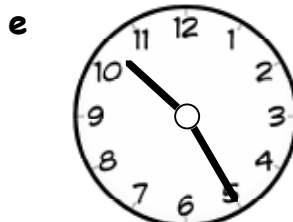
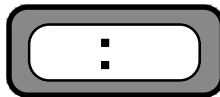
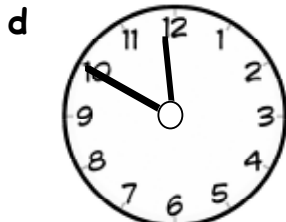
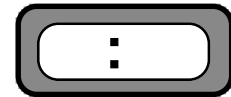
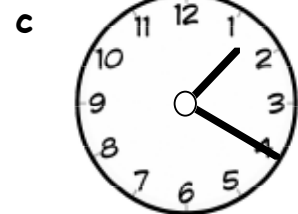
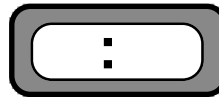
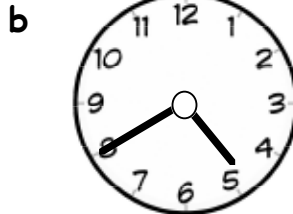
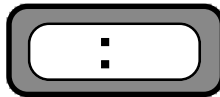
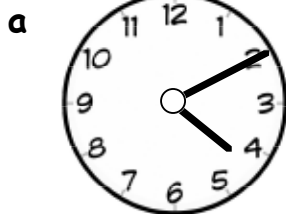

Show this to your teacher, then go to page 35 question 3

1. Complete each division :-

a  $\frac{\square}{4 \overline{)41}}$

b  $\frac{\square}{4 \overline{)45}}$

c  $\frac{\square}{4 \overline{)48}}$

d  $\frac{\square}{4 \overline{)47}}$

e  $\frac{\square}{4 \overline{)44}}$

f  $\frac{\square}{4 \overline{)80}}$

g  $\frac{\square}{4 \overline{)40}}$

h  $\frac{\square}{4 \overline{)83}}$

i  $\frac{\square}{4 \overline{)89}}$

j  $\frac{\square}{4 \overline{)88}}$

k  $\frac{\square}{4 \overline{)86}}$

l  $\frac{\square}{4 \overline{)840}}$

2. Show all your working.

a 43 fish were **divided equally** among 4 tanks.

How many fish were in each tank and how many were left over ?

	..... each
	.....left over



b Each crate can hold 4 large dolls.

How many full crates can be packed if there are 81 dolls and how many dolls are left over ?

	..... crates
	.....left over



cont'd over page .....

3. Complete each calculation :-

a  $\frac{\square}{4 \overline{)73}}$

b  $\frac{\square}{4 \overline{)57}}$

c  $\frac{\square}{4 \overline{)69}}$

d  $\frac{\square}{4 \overline{)82}}$

e  $\frac{\square}{4 \overline{)53}}$

f  $\frac{\square}{4 \overline{)38}}$

g  $\frac{\square}{4 \overline{)43}}$

h  $\frac{\square}{4 \overline{)77}}$

i  $\frac{\square}{4 \overline{)93}}$

j  $\frac{\square}{4 \overline{)75}}$

k  $\frac{\square}{4 \overline{)87}}$

l  $\frac{\square}{4 \overline{)491}}$

4. Show all your working.

- a 59 boxes of coconuts were **divided equally** among 4 shops.  
How many boxes did each shop get and how many were left over ?

..... boxes  
.....left over



- b Each new car needs 4 tyres.  
How many cars can be fitted with 37 tyres and how many tyres will be left over?

..... cars  
.....left over



- c How many toy cars are left over if I **share equally** 77 cars between Ben and his three friends.

.....left over



Show this to your teacher, then go to page 50 Exercise 2

1. Complete each calculation :-

a  $\boxed{\phantom{00}}$   
 $5 \overline{)20}$

b  $\boxed{\phantom{00}}$   
 $5 \overline{)35}$

c  $\boxed{\phantom{00}}$   
 $5 \overline{)40}$

d  $\boxed{\phantom{00}}$   
 $5 \overline{)15}$

e  $\boxed{\phantom{00}}$   
 $5 \overline{)14}$

f  $\boxed{\phantom{00}}$   
 $5 \overline{)9}$

g  $\boxed{\phantom{00}}$   
 $5 \overline{)18}$

h  $\boxed{\phantom{00}}$   
 $5 \overline{)22}$

i  $\boxed{\phantom{00}}$   
 $5 \overline{)16}$

j  $\boxed{\phantom{00}}$   
 $5 \overline{)8}$

k  $\boxed{\phantom{00}}$   
 $5 \overline{)27}$

l  $\boxed{\phantom{00}}$   
 $5 \overline{)31}$

m  $\boxed{\phantom{00}}$   
 $5 \overline{)26}$

n  $\boxed{\phantom{00}}$   
 $5 \overline{)11}$

o  $\boxed{\phantom{00}}$   
 $5 \overline{)41}$

p  $\boxed{\phantom{00}}$   
 $5 \overline{)192}$

2. Show all your working.

a 45 shirts were **stored equally** on 5 shelves.  
How many shirts were on each shelf ?

b A bowl containing 59 cherries  
was **split equally** into 5 small bags.  
How many were in each small bag  
and how many were left over ?



..... cherries

.....left over

cont'd over page .....

3. Complete each calculation :-

a  $\begin{array}{r} \square \\ 5 \overline{) 27} \end{array}$

b  $\begin{array}{r} \square \\ 5 \overline{) 51} \end{array}$

c  $\begin{array}{r} \square \\ 5 \overline{) 71} \end{array}$

d  $\begin{array}{r} \square \\ 5 \overline{) 59} \end{array}$

e  $\begin{array}{r} \square \\ 5 \overline{) 34} \end{array}$

f  $\begin{array}{r} \square \\ 5 \overline{) 66} \end{array}$

g  $\begin{array}{r} \square \\ 5 \overline{) 82} \end{array}$

h  $\begin{array}{r} \square \\ 5 \overline{) 79} \end{array}$

i  $\begin{array}{r} \square \\ 5 \overline{) 48} \end{array}$

j  $\begin{array}{r} \square \\ 5 \overline{) 77} \end{array}$

k  $\begin{array}{r} \square \\ 5 \overline{) 39} \end{array}$

l  $\begin{array}{r} \square \\ 5 \overline{) 19} \end{array}$

m  $\begin{array}{r} \square \\ 5 \overline{) 61} \end{array}$

n  $\begin{array}{r} \square \\ 5 \overline{) 42} \end{array}$

o  $\begin{array}{r} \square \\ 5 \overline{) 88} \end{array}$

p  $\begin{array}{r} \square \\ 5 \overline{) 531} \end{array}$

4. Show all your working.

a A bag can hold 5 bowling balls.  
78 bowling balls were packed **equally**.

How many balls were left over ?

.....left over

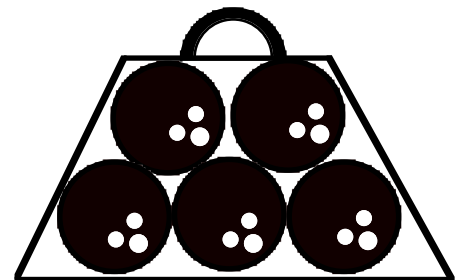

b Carol, Danni, Jen and their two friends **share** 65 Scrunchies **equally**.

How many Scrunchies will each girl get ?

..... each

Show this to your teacher, then go to page 55 Exercise 4



1. Mark with a small box any right angles below :-

a



b

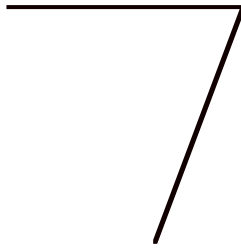

c

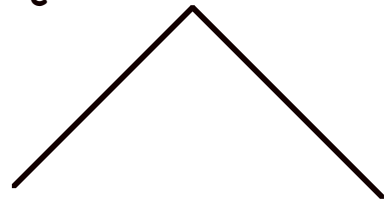

d

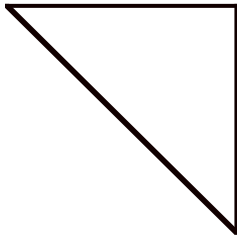

e

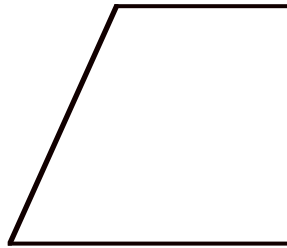

f

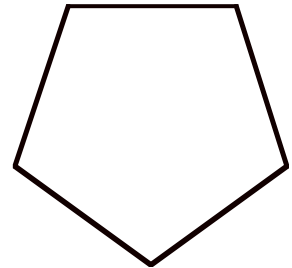

2. Mark all right angles in each diagram.

a

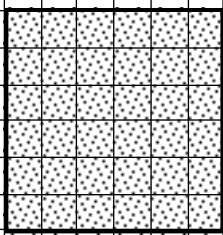

b

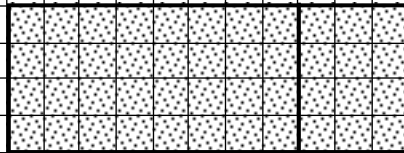

c

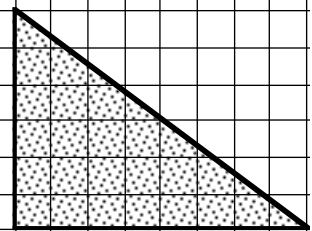

d

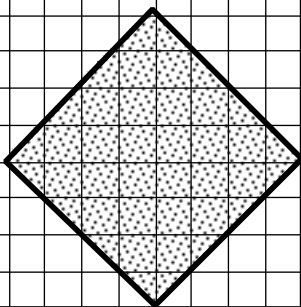

e

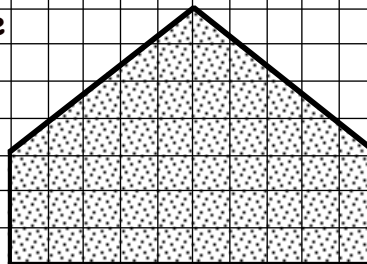

f

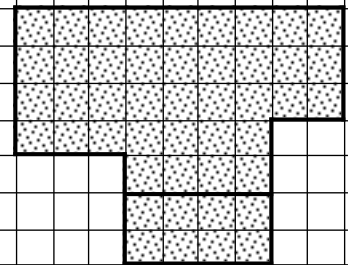

g

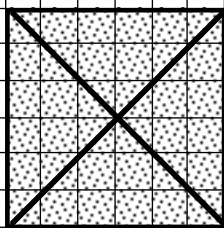

h

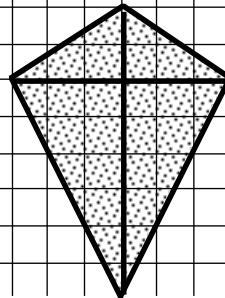

i

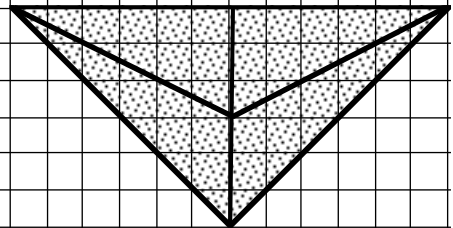

cont'd over page .....

3. Use your **template** to find the 7 Right Angles. Tick **YES** or **NO** in the box.

a

yes	
no	

b

yes	
no	

c

yes	
no	

d

yes	
no	

e

yes	
no	

f

yes	
no	

g

yes	
no	

h

yes	
no	

i

yes	
no	

j

yes	
no	

k

yes	
no	

l

yes	
no	

Show this to your teacher, then go to page 68 Question 2

1. a The third month of the year is
- b  is the month before October.
- c Four months after October is
- d There are  months in a year.
- e There are  days in November.
- f There are  days in May.
- g There are  days in January.

2. Write the months of the year backwards :-

December - November - October

S		

3. Complete the calendar shown for June.

a List the dates of all the Fridays :-

4th, , ,

b The third Monday in

June is the  st.

c Which day of the week is the 1st of July ?

Answer -

June 2003						
Su	Mo	Tu	We	Th	Fr	Sa
		1	2	...	...	...
...	...	...	9	10	...	...
...	...	...	...	...	...	...
...	...	...	...	...	...	...

cont'd over page .....

4. a Complete the dates of the two months below :-

March 2012						
Su	Mo	Tu	We	Th	Fr	Sa
...	...	...	...	...	...	...
4	...	...	...	...	...	...
...	...	...	...	...	...	...
...	...	...	...	...	...	...
...	...	...	...	...	...	31

April 2012						
Su	Mo	Tu	We	Th	Fr	Sa
...	...	...	...	...	...	...
...	...	...	...	...	13	14
15	16	...	...	...	...	...
...	...	...	...	...	...	...
...	...	...	...	...	...	...

b Which day of the week is the 12th April 2012 ?

c Which day of the week is the 29th March 2012 ?

d Which day of the week is 1st May 2012 ?

e Which day of the week is 29th February 2012 ?

Write down the date of :-

f the first Thursday in April 2012 -

g the last Friday in March 2012 -

h the 3rd Tuesday in March 2012 -

5. Harder. Complete the October calendar.

Which day of the week is :-

a 30th September

b 1st November

c 8th November

d 28th September

October 2012						
Su	Mo	Tu	We	Th	Fr	Sa
...	...	...	...	...	...	...
...	...	...	...	...	...	...
...	...	...	...	...	...	...
...	...	30	...	...	...	...

**Show this to your teacher, then go to page 85 Exercise 1**

1. These grids are to go with questions 5 to 10 on pages 95 and 96 of the textbook.

Qu 5

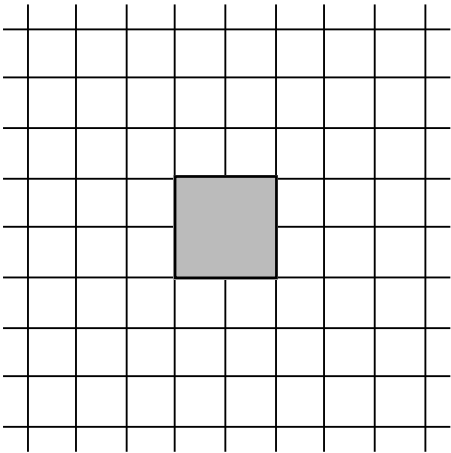

Qu 6

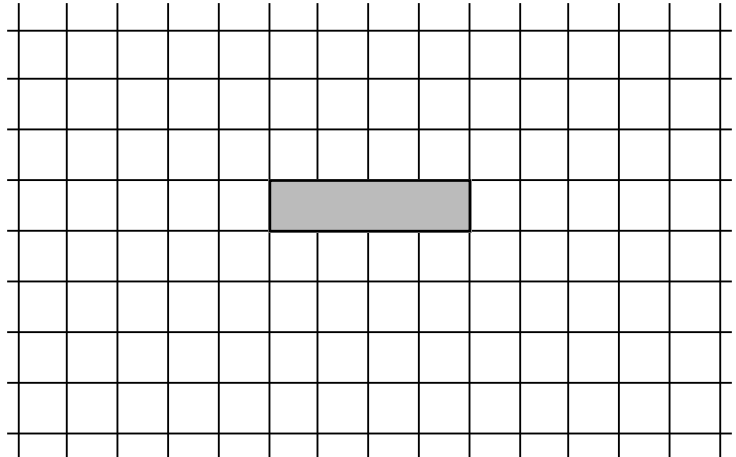

Qu 7

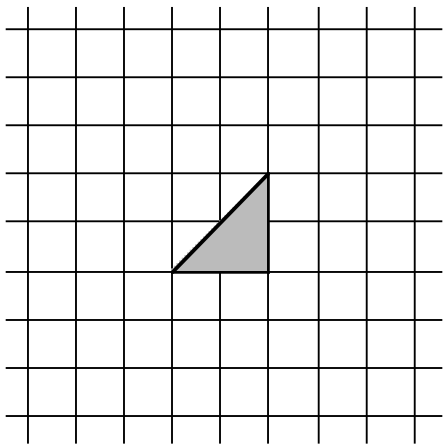

Qu 8

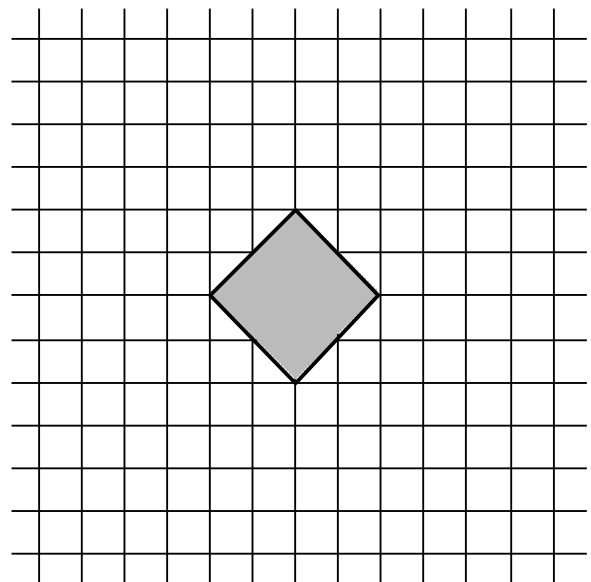

Qu 9

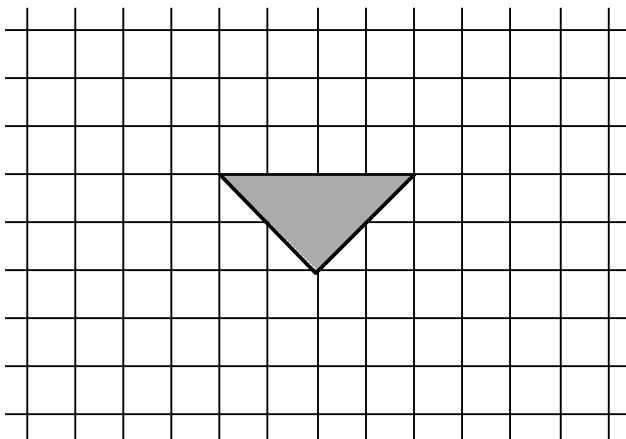

Qu 10

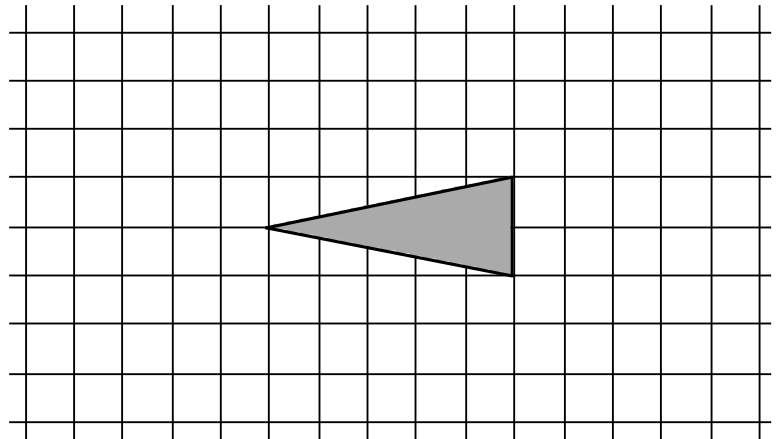

Show this to your teacher.

These grids are to go with questions 3, 4a and 4b on page 99 of the textbook.

Qu 3

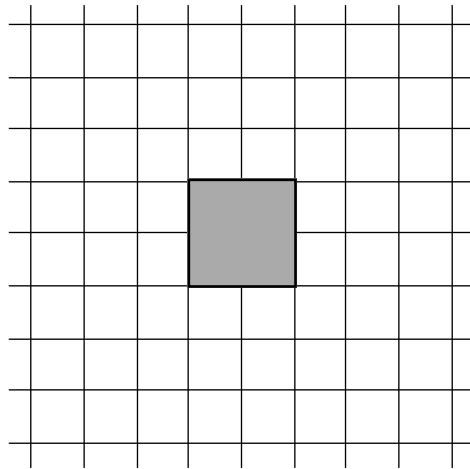

Qu 4a

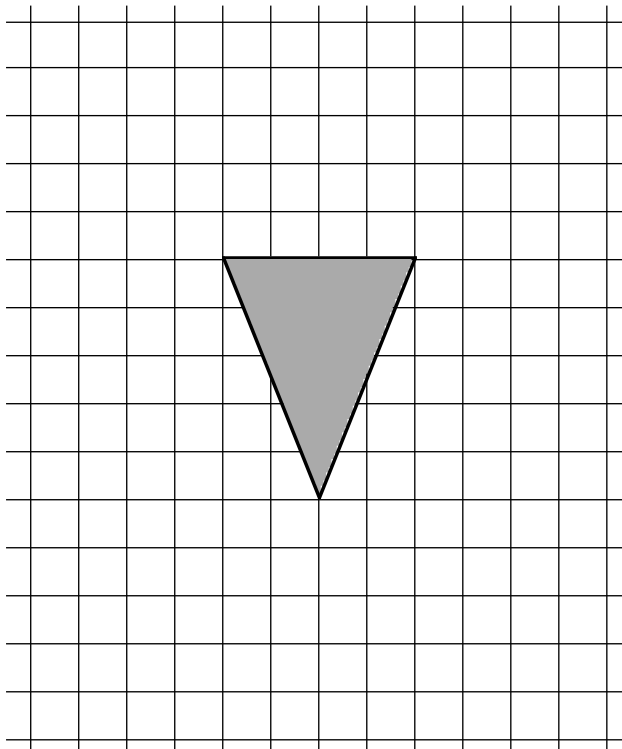

Qu 4b

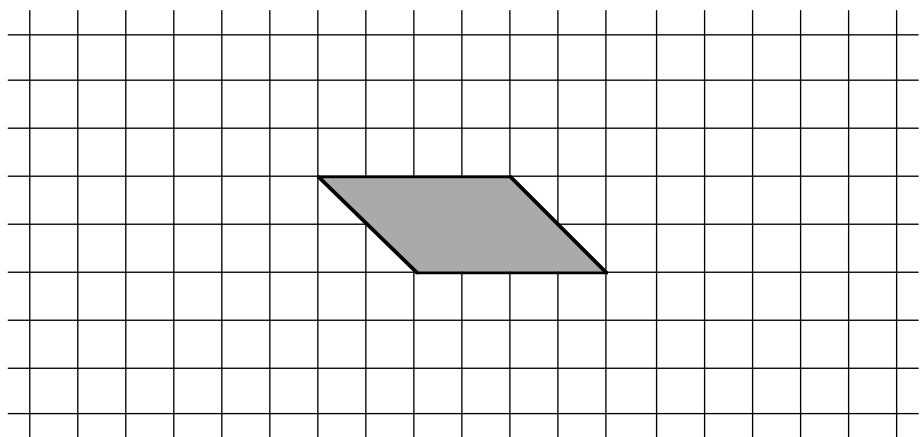

These grids are to go with questions 4c, 4d, 5, and 6 on page 100 of the textbook.

Qu 4c

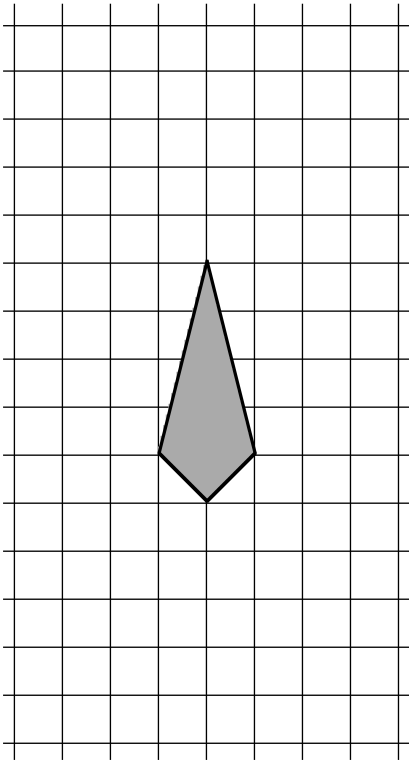

Qu 4d

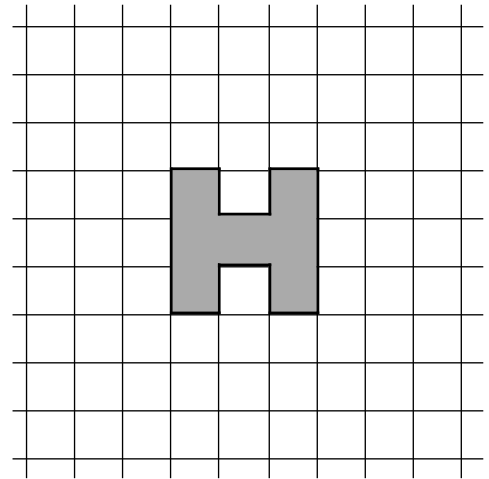

Qu 5a

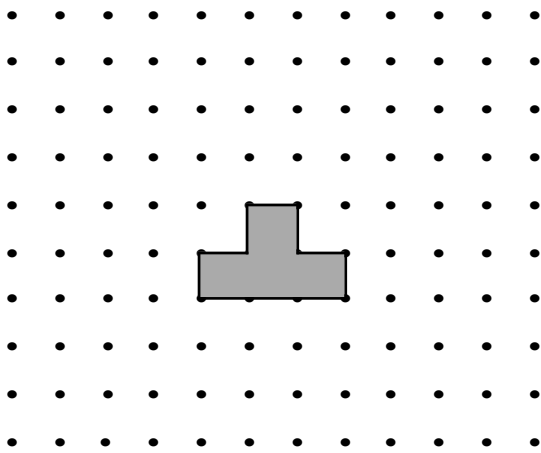

Qu 5b

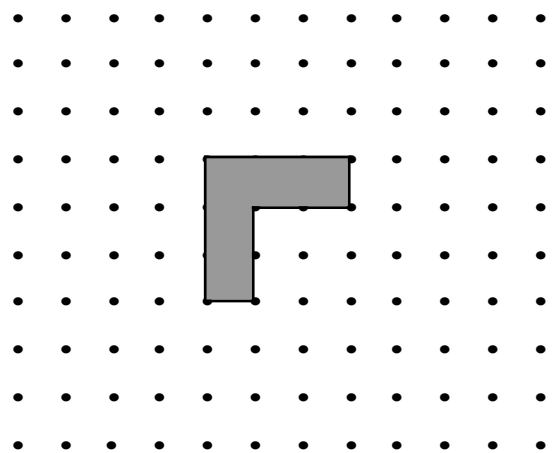

Qu 6

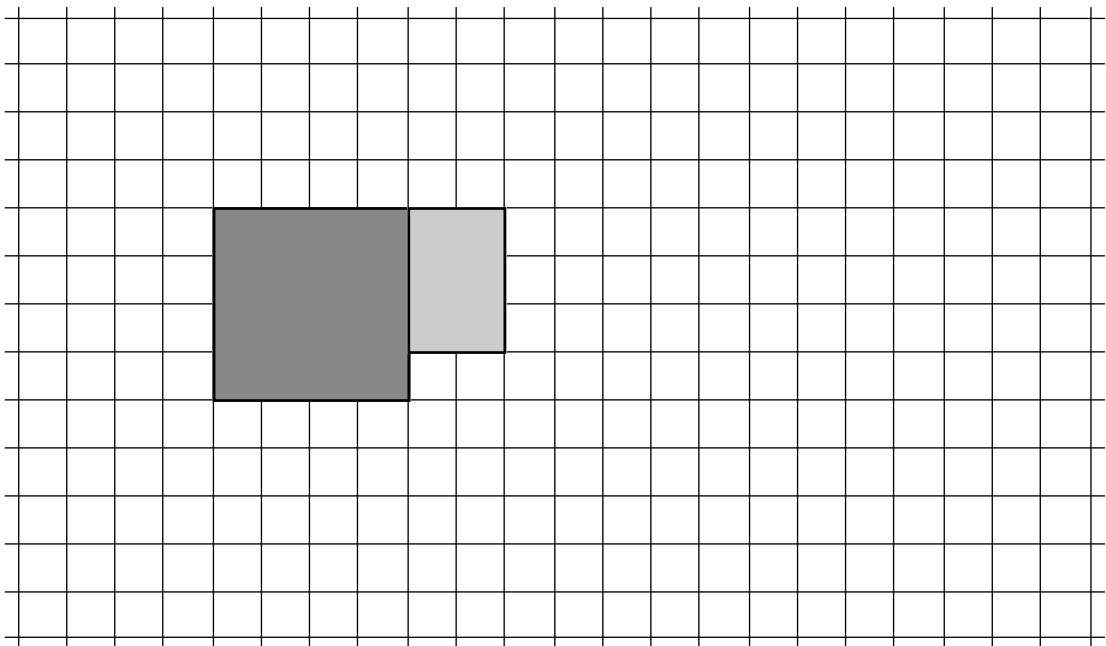

## The 6 times table

Complete the 6 times table :-

$$6 \text{ sets of } 0 = 0$$

$$6 \text{ sets of } 1 = 6$$

$$6 \text{ sets of } 2 = 12$$

$$6 \text{ sets of } 3 = 18$$

$$6 \text{ sets of } 4 = 24$$

$$6 \text{ sets of } \dots = \dots$$

$$6 \text{ sets of } \dots = \dots$$

$$6 \text{ sets of } \dots = \dots$$

$$6 \text{ sets of } \dots = \dots$$

$$6 \text{ sets of } \dots = \dots$$

$$6 \text{ sets of } \dots = \dots$$

$$6 \times 0 = 0$$

$$6 \times 1 = 6$$

$$6 \times 2 = 12$$

$$6 \times 3 = 18$$

$$6 \times 4 = \dots$$

$$6 \times 5 = \dots$$

$$6 \times 6 = \dots$$

$$6 \times 7 = \dots$$

$$6 \times \dots = \dots$$

$$6 \times \dots = \dots$$

$$6 \dots \dots = \dots$$

**LEARN**

Memorise the 6 times table, go to Page 103 Exercise 1, then go to the next sheet



Complete these multiplications :-

$$\begin{array}{r} 1 \quad 17 \\ \times 6 \\ \hline \end{array}$$

$$\begin{array}{r} 2 \quad 47 \\ \times 6 \\ \hline \end{array}$$

$$\begin{array}{r} 3 \quad 58 \\ \times 6 \\ \hline \end{array}$$

$$\begin{array}{r} 4 \quad 36 \\ \times 6 \\ \hline \end{array}$$

$$\begin{array}{r} 5 \quad 40 \\ \times 6 \\ \hline \end{array}$$

$$\begin{array}{r} 6 \quad 51 \\ \times 6 \\ \hline \end{array}$$

$$\begin{array}{r} 7 \quad 39 \\ \times 6 \\ \hline \end{array}$$

$$\begin{array}{r} 8 \quad 33 \\ \times 6 \\ \hline \end{array}$$

$$\begin{array}{r} 9 \quad 71 \\ \times 6 \\ \hline \end{array}$$

$$\begin{array}{r} 10 \quad 45 \\ \times 6 \\ \hline \end{array}$$

$$\begin{array}{r} 11 \quad 26 \\ \times 6 \\ \hline \end{array}$$

$$\begin{array}{r} 12 \quad 67 \\ \times 6 \\ \hline \end{array}$$

$$\begin{array}{r} 13 \quad 50 \\ \times 6 \\ \hline \end{array}$$

$$\begin{array}{r} 14 \quad 44 \\ \times 6 \\ \hline \end{array}$$

$$\begin{array}{r} 15 \quad 58 \\ \times 6 \\ \hline \end{array}$$

$$\begin{array}{r} 16 \quad 65 \\ \times 6 \\ \hline \end{array}$$

$$\begin{array}{r} 17 \quad 53 \\ \times 6 \\ \hline \end{array}$$

$$\begin{array}{r} 18 \quad 37 \\ \times 6 \\ \hline \end{array}$$

$$\begin{array}{r} 19 \quad 28 \\ \times 6 \\ \hline \end{array}$$

$$\begin{array}{r} 20 \quad 91 \\ \times 6 \\ \hline \end{array}$$

$$\begin{array}{r} 21 \quad 180 \\ \times 6 \\ \hline \end{array}$$

**Show this to your teacher, then go to page 105 Exercise 2**

## The 7 times table

Complete the 7 times table :-

$$7 \text{ sets of } 0 = 0$$

$$7 \text{ sets of } 1 = 7$$

$$7 \text{ sets of } 2 = 14$$

$$7 \text{ sets of } 3 = 21$$

$$7 \text{ sets of } 4 = \dots$$

$$7 \text{ sets of } \dots = \dots$$

$$7 \text{ sets of } \dots = \dots$$

$$7 \text{ sets of } \dots = \dots$$

$$7 \text{ sets of } \dots = \dots$$

$$7 \text{ sets of } \dots = \dots$$

$$7 \text{ sets of } \dots = \dots$$

$$7 \times 0 = 0$$

$$7 \times 1 = 7$$

$$7 \times 2 = 14$$

$$7 \times 3 = \dots$$

$$7 \times 4 = \dots$$

$$7 \times 5 = \dots$$

$$7 \times 6 = \dots$$

$$7 \times 7 = \dots$$

$$7 \times \dots = \dots$$

$$7 \times \dots = \dots$$

$$7 \dots \dots = \dots$$

**LEARN**

Memorise the 7 times table, go to Page 107 Exercise 3, then go to the next sheet

Complete these multiplications :-

$$\begin{array}{r} 1 \quad 19 \\ \times 7 \\ \hline \end{array}$$

$$\begin{array}{r} 2 \quad 38 \\ \times 7 \\ \hline \end{array}$$

$$\begin{array}{r} 3 \quad 49 \\ \times 7 \\ \hline \end{array}$$

$$\begin{array}{r} 4 \quad 54 \\ \times 7 \\ \hline \end{array}$$

$$\begin{array}{r} 5 \quad 60 \\ \times 7 \\ \hline \end{array}$$

$$\begin{array}{r} 6 \quad 31 \\ \times 7 \\ \hline \end{array}$$

$$\begin{array}{r} 7 \quad 59 \\ \times 7 \\ \hline \end{array}$$

$$\begin{array}{r} 8 \quad 37 \\ \times 7 \\ \hline \end{array}$$

$$\begin{array}{r} 9 \quad 91 \\ \times 7 \\ \hline \end{array}$$

$$\begin{array}{r} 10 \quad 48 \\ \times 7 \\ \hline \end{array}$$

$$\begin{array}{r} 11 \quad 34 \\ \times 7 \\ \hline \end{array}$$

$$\begin{array}{r} 12 \quad 66 \\ \times 7 \\ \hline \end{array}$$

$$\begin{array}{r} 13 \quad 50 \\ \times 7 \\ \hline \end{array}$$

$$\begin{array}{r} 14 \quad 73 \\ \times 7 \\ \hline \end{array}$$

$$\begin{array}{r} 15 \quad 45 \\ \times 7 \\ \hline \end{array}$$

$$\begin{array}{r} 16 \quad 68 \\ \times 7 \\ \hline \end{array}$$

$$\begin{array}{r} 17 \quad 72 \\ \times 7 \\ \hline \end{array}$$

$$\begin{array}{r} 18 \quad 46 \\ \times 7 \\ \hline \end{array}$$

$$\begin{array}{r} 19 \quad 25 \\ \times 7 \\ \hline \end{array}$$

$$\begin{array}{r} 20 \quad 71 \\ \times 7 \\ \hline \end{array}$$

$$\begin{array}{r} 21 \quad 170 \\ \times 7 \\ \hline \end{array}$$

Show this to your teacher, then go to page 109 Exercise 4

These questions are from textbook Chapter 11 page 117 questions 7, 8 and 9.

Use the grids below and coloured pencils to follow each set of instructions.

7. a Colour B2 red.  
 b Colour these squares blue:-  
     A2, D5, E1  
 c Colour C1, C4 and E3 brown.  
 d Colour A1 and B5 pink.

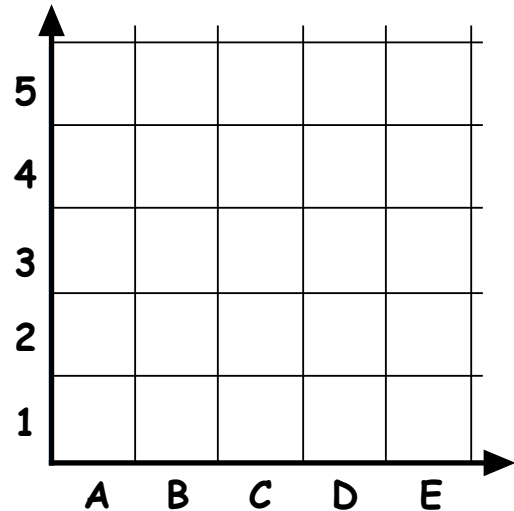

8. Use this grid and follow the instructions.

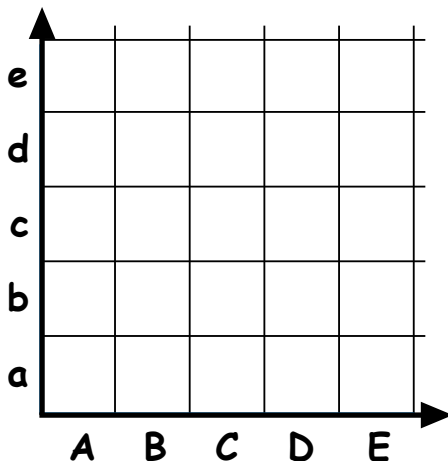

- a Colour these squares blue :-  
     Bb, De, Ea, and Ae.  
 b Colour these squares red :-  
     Ce, Cc, Aa and Ec.

9. Use this grid and follow the instructions.

- a This time make a pattern of your own, using colours.  
 b For each square you coloured in, write down its colour and its grid position.  
 (Example : red - B2)

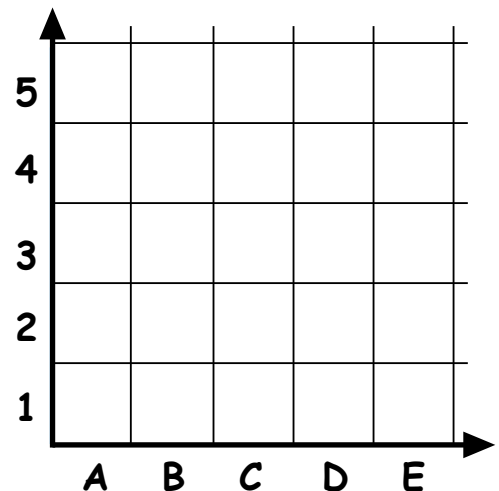

**Show this to your teacher, then go to page 118 Question 10**

## The 8 times table

Complete the 8 times table :-

$$8 \text{ sets of } 0 = 0$$

$$8 \text{ sets of } 1 = 8$$

$$8 \text{ sets of } 2 = 16$$

$$8 \text{ sets of } 3 = 24$$

$$8 \text{ sets of } 4 = \dots$$

$$8 \text{ sets of } \dots = \dots$$

$$8 \text{ sets of } \dots = \dots$$

$$8 \text{ sets of } \dots = \dots$$

$$8 \text{ sets of } \dots = \dots$$

$$8 \text{ sets of } \dots = \dots$$

$$8 \text{ sets of } \dots = \dots$$

$$8 \times 0 = 0$$

$$8 \times 1 = 8$$

$$8 \times 2 = 16$$

$$8 \times 3 = \dots$$

$$8 \times 4 = \dots$$

$$8 \times 5 = \dots$$

$$8 \times 6 = \dots$$

$$8 \times 7 = \dots$$

$$8 \times \dots = \dots$$

$$8 \times \dots = \dots$$

$$8 \dots \dots = \dots$$

**LEARN**

Memorise the 8 times table, go to Page 125 Exercise 1, then go to the next sheet

Complete these multiplications :-

$$\begin{array}{r} 1 \quad 17 \\ \times 8 \\ \hline \square \end{array}$$

$$\begin{array}{r} 2 \quad 46 \\ \times 8 \\ \hline \square \end{array}$$

$$\begin{array}{r} 3 \quad 54 \\ \times 8 \\ \hline \square \end{array}$$

$$\begin{array}{r} 4 \quad 37 \\ \times 8 \\ \hline \square \end{array}$$

$$\begin{array}{r} 5 \quad 40 \\ \times 8 \\ \hline \square \end{array}$$

$$\begin{array}{r} 6 \quad 51 \\ \times 8 \\ \hline \square \end{array}$$

$$\begin{array}{r} 7 \quad 47 \\ \times 8 \\ \hline \square \end{array}$$

$$\begin{array}{r} 8 \quad 52 \\ \times 8 \\ \hline \square \end{array}$$

$$\begin{array}{r} 9 \quad 53 \\ \times 8 \\ \hline \square \end{array}$$

$$\begin{array}{r} 10 \quad 36 \\ \times 8 \\ \hline \square \end{array}$$

$$\begin{array}{r} 11 \quad 34 \\ \times 8 \\ \hline \square \end{array}$$

$$\begin{array}{r} 12 \quad 39 \\ \times 8 \\ \hline \square \end{array}$$

$$\begin{array}{r} 13 \quad 50 \\ \times 8 \\ \hline \square \end{array}$$

$$\begin{array}{r} 14 \quad 55 \\ \times 8 \\ \hline \square \end{array}$$

$$\begin{array}{r} 15 \quad 79 \\ \times 8 \\ \hline \square \end{array}$$

$$\begin{array}{r} 16 \quad 75 \\ \times 8 \\ \hline \square \end{array}$$

$$\begin{array}{r} 17 \quad 63 \\ \times 8 \\ \hline \square \end{array}$$

$$\begin{array}{r} 18 \quad 77 \\ \times 8 \\ \hline \square \end{array}$$

$$\begin{array}{r} 19 \quad 36 \\ \times 8 \\ \hline \square \end{array}$$

$$\begin{array}{r} 20 \quad 92 \\ \times 8 \\ \hline \square \end{array}$$

$$\begin{array}{r} 21 \quad 290 \\ \times 8 \\ \hline \square \end{array}$$

Show this to your teacher, then go to page 127 Exercise 2

## The 9 times table

Complete the 9 times table :-

$$9 \text{ sets of } 0 = 0$$

$$9 \text{ sets of } 1 = 9$$

$$9 \text{ sets of } 2 = 18$$

$$9 \text{ sets of } 3 = 27$$

$$9 \text{ sets of } 4 = \dots$$

$$9 \text{ sets of } \dots = \dots$$

$$9 \text{ sets of } \dots = \dots$$

$$9 \text{ sets of } \dots = \dots$$

$$9 \text{ sets of } \dots = \dots$$

$$9 \text{ sets of } \dots = \dots$$

$$9 \text{ sets of } \dots = \dots$$

$$9 \times 0 = 0$$

$$9 \times 1 = 9$$

$$9 \times 2 = 18$$

$$9 \times 3 = \dots$$

$$9 \times 4 = \dots$$

$$9 \times 5 = \dots$$

$$9 \times 6 = \dots$$

$$9 \times 7 = \dots$$

$$9 \times \dots = \dots$$

$$9 \times \dots = \dots$$

$$9 \dots \dots = \dots$$

**LEARN**

Memorise the 9 times table, go to Page 129 Exercise 3, then go to the next sheet

Complete these multiplications :-

1     14  
   x 9  
-----

2     23  
   x 9  
-----

3     31  
   x 9  
-----

4     42  
   x 9  
-----

5     20  
   x 9  
-----

6     41  
   x 9  
-----

7     53  
   x 9  
-----

8     44  
   x 9  
-----

9     61  
   x 9  
-----

10    38  
   x 9  
-----

11    29  
   x 9  
-----

12    66  
   x 9  
-----

13    40  
   x 9  
-----

14    63  
   x 9  
-----

15    72  
   x 9  
-----

16    83  
   x 9  
-----

17    62  
   x 9  
-----

18    33  
   x 9  
-----

19    39  
   x 9  
-----

20    81  
   x 9  
-----

21    390  
   x 9  
-----

Show this to your teacher, then go to page 131 Exercise 4



name ..... score :- .....

1. a Mark on this grid with coloured pencils any number patterns that you can find.

X	1	2	3	4	5	6	7	8	9
1	1	2	3	4	5	6	7	8	9
2	2	4	6	8	10	12	14	16	18
3	3	6	9	12	15	18	21	24	27
4	4	8	12	16	20	24	28	32	36
5	5	10	15	20	25	30	35	40	45
6	6	12	18	24	30	36	42	48	54
7	7	14	21	28	35	42	49	56	63
8	8	16	24	32	40	48	56	64	72
9	9	18	27	36	45	54	63	72	81

b Describe below any number patterns you found :-

**Show this to your teacher, then go to page 143 Question 3**

1. Use your own ruler to measure these lines and write your answers in the box to the nearest centimetre.

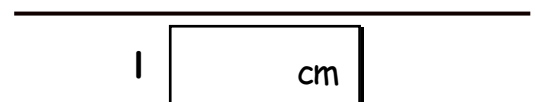
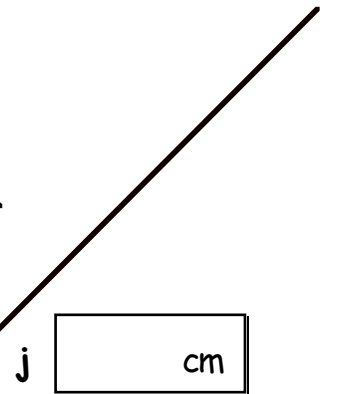
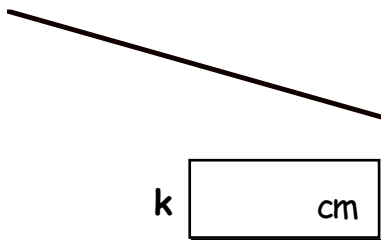
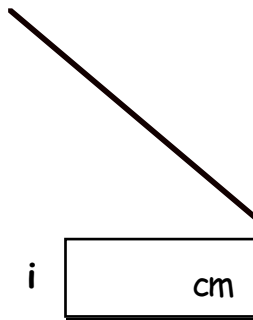
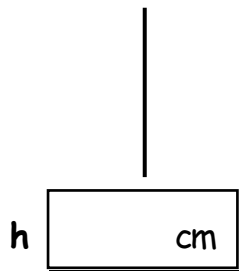
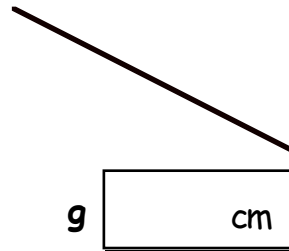
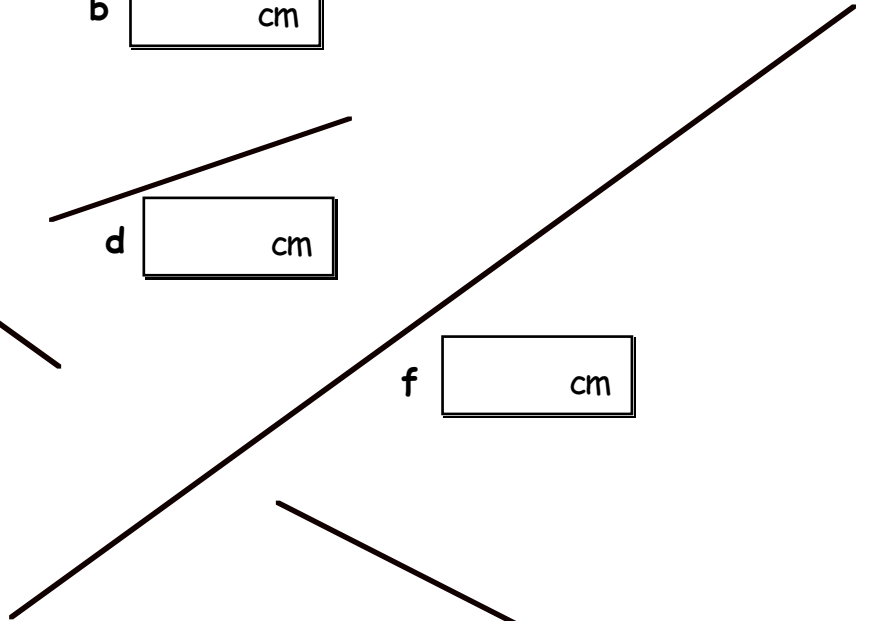
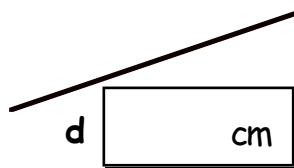
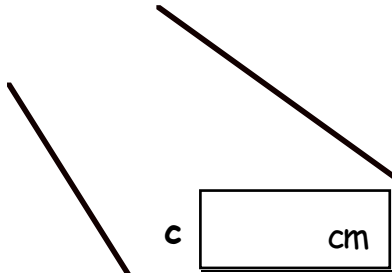
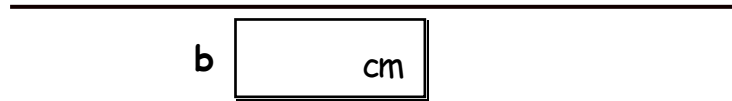
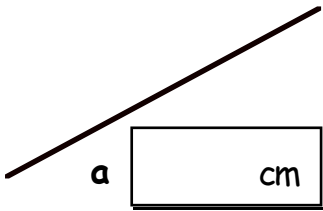

Show this to your teacher, then go to page 175 Exercise 1

1. Write down the lengths of these objects to the nearest centimetre.

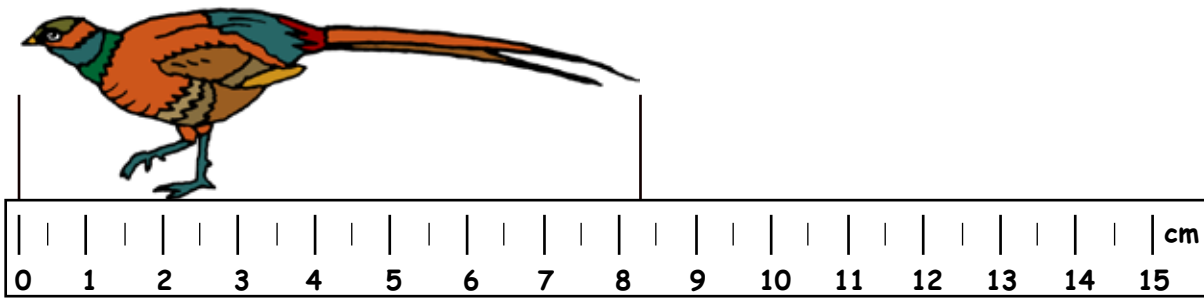

a  
cm

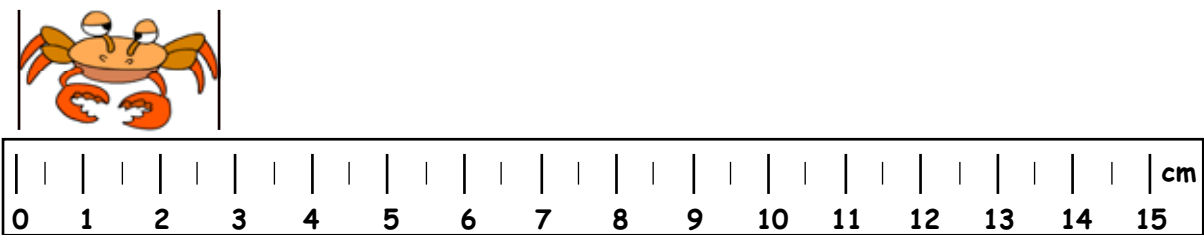

b  
cm

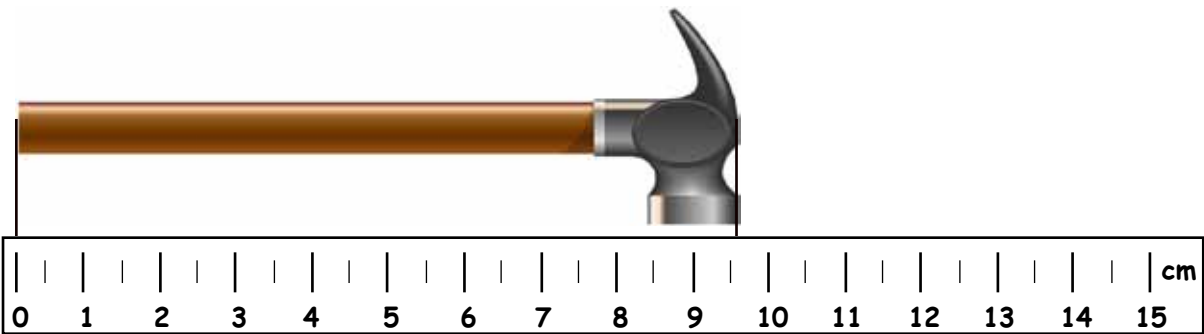

c  
cm

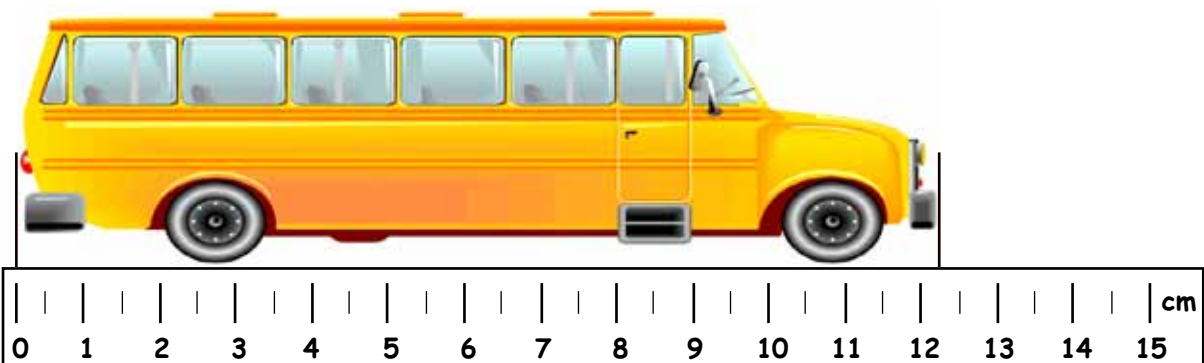

d  
cm

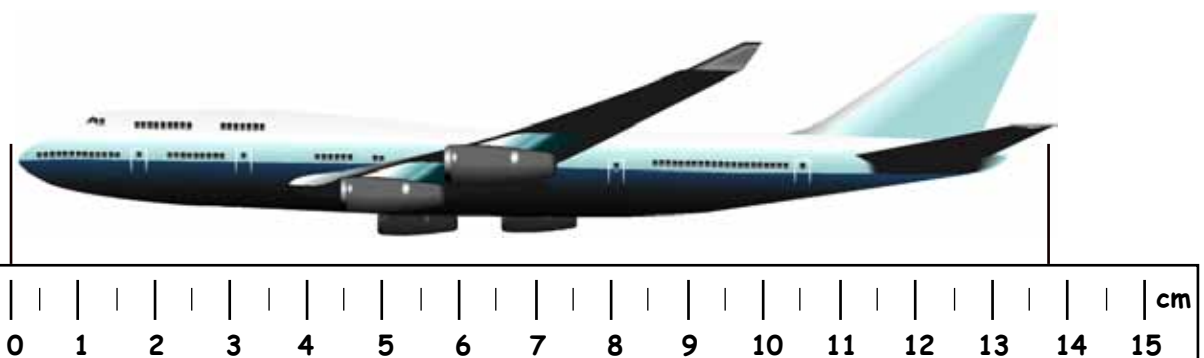

e  
cm

cont'd over page .....

2. Measure the size of each picture and write in your answer to the nearest centimetre.

b  cm  
 c  cm  
 a  cm  
 d  cm  
 e  cm  
 f  cm  
 g  cm  
 h  cm  
 i  cm

Show this to your teacher, then go to page 176 Question 4

1. Write down the area (...cm<sup>2</sup>) of each shape below :-

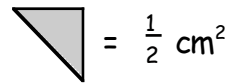

a

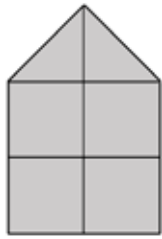

cm<sup>2</sup>

b

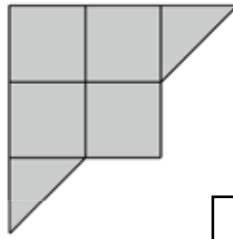

cm<sup>2</sup>

c

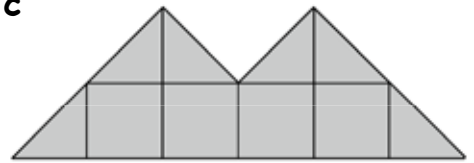

cm<sup>2</sup>

d

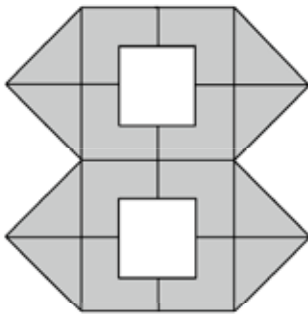

cm<sup>2</sup>

e

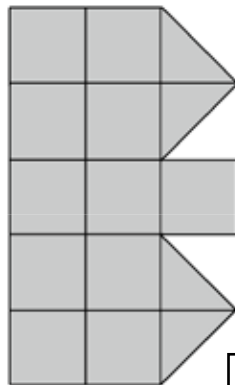

cm<sup>2</sup>

f

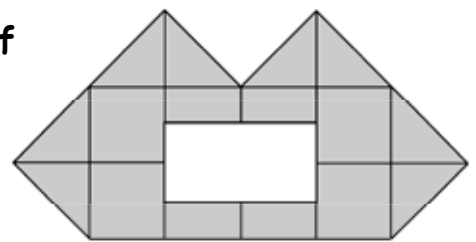

cm<sup>2</sup>

g

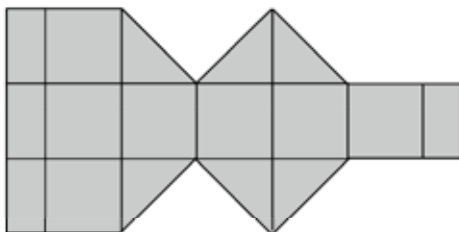

cm<sup>2</sup>

h

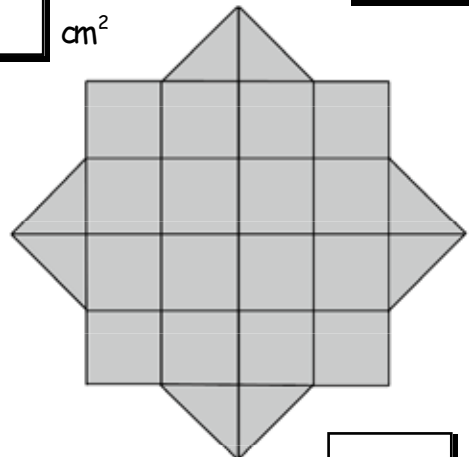

cm<sup>2</sup>

i

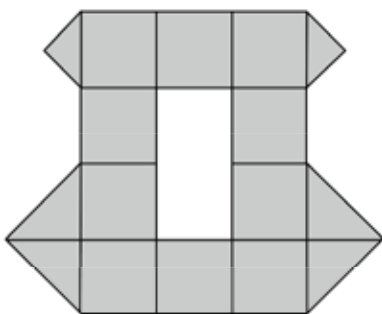

cm<sup>2</sup>

j

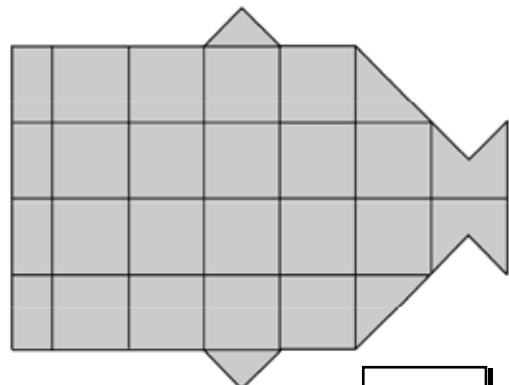

cm<sup>2</sup>

Show this to your teacher.

1. Estimate the area (...cm<sup>2</sup>) of the following shapes :-

a

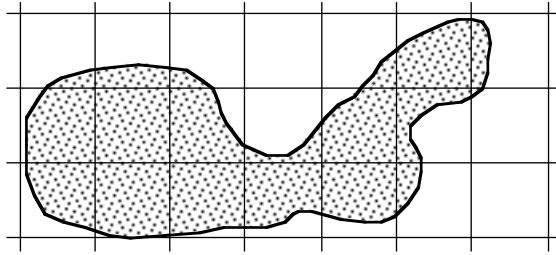

cm<sup>2</sup>

b

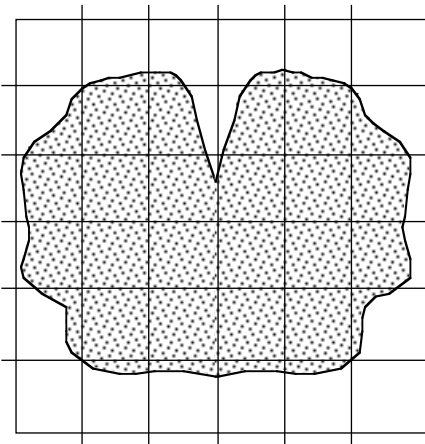

c

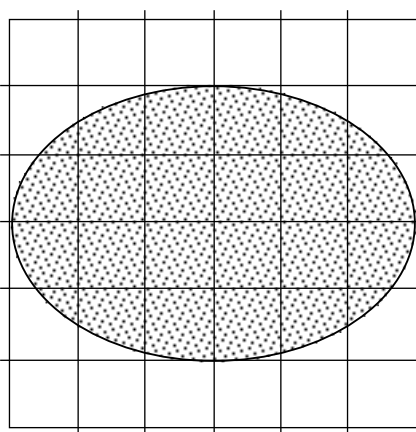

d

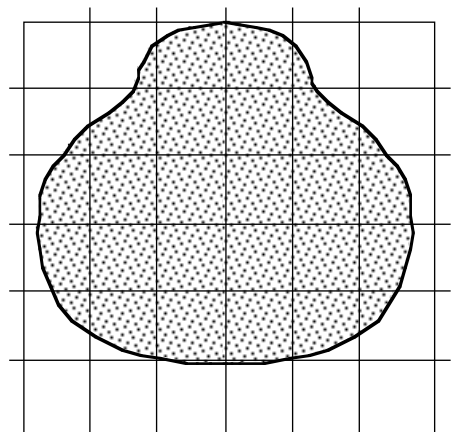

e

cm<sup>2</sup>

cm<sup>2</sup>

cm<sup>2</sup>

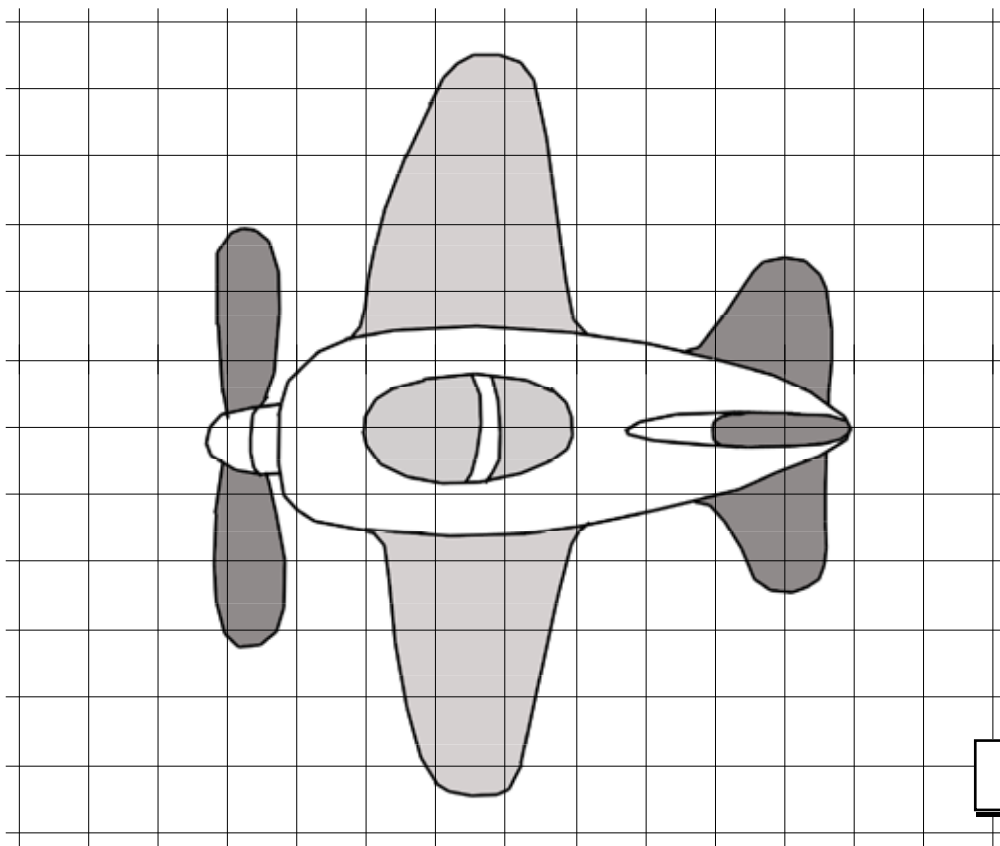

cm<sup>2</sup>

Show this to your teacher, then go to page 181 Exercise 4

These questions are from textbook Chapter 16 page 186 questions 8 and 9.

8. a What is  $\frac{1}{6}$  of 24 ?

b Colour  $\frac{1}{6}$  of the rectangle red.

c Colour  $\frac{1}{8}$  of it blue  
and  $\frac{1}{4}$  of it yellow.

d How many squares are not coloured ?

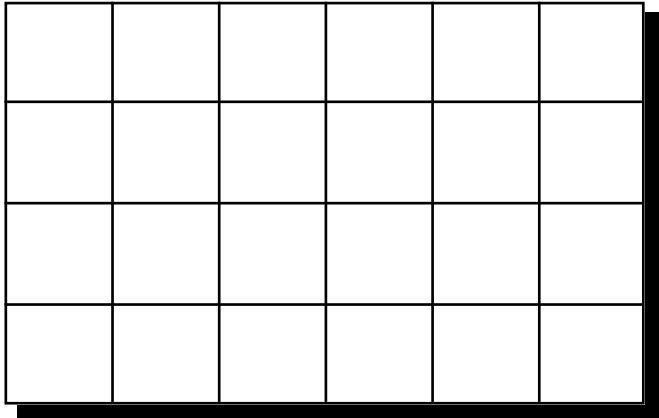

9. a Colour :-

- one half red
- one quarter blue
- one eighth green.

b How many squares are not coloured ?

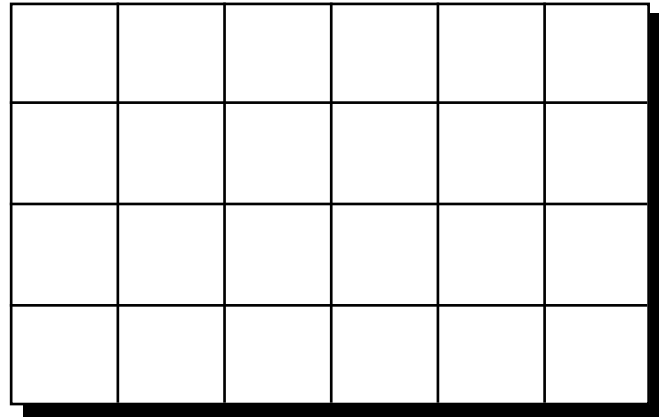

**Extra question**

a How many small triangles ?

b Colour  $\frac{1}{2}$  of the shape red.

c Colour  $\frac{1}{6}$  of the shape blue.

d Colour  $\frac{1}{4}$  of the shape green.

e How many triangles are not coloured ?

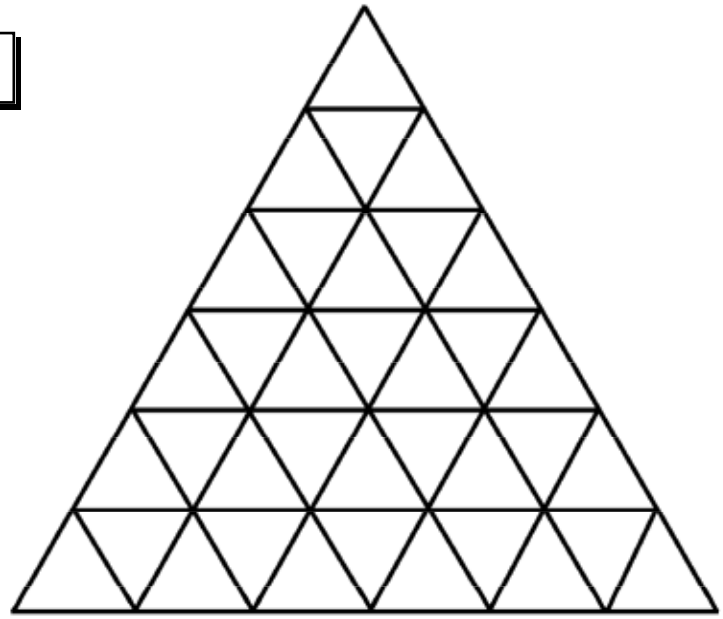

**Show this to your teacher, then go to page 187 Question 10**

These questions are from textbook Chapter 16 page 189 questions 4 and 5.

4. a Colour in 2 boxes red in figure 1.

b What fraction have you shaded ?

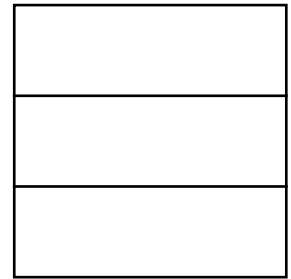

figure 1

c Colour in the correct number of boxes in figure 2 so that both figures look the same.

d Use your drawings to complete :-

$$\frac{\square}{3} = \frac{\square}{6}$$

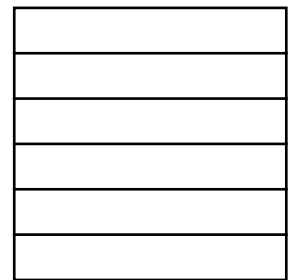

figure 2

5. a Colour in 3 parts of this circle in figure 3.

b What fraction have you shaded ?

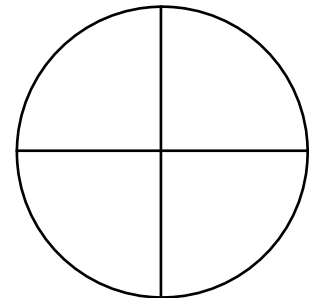

figure 3

c Colour in the correct number of parts in figure 4 so that both figures look the same.

d Use your drawings to complete :-

$$\frac{\square}{4} = \frac{6}{\square}$$

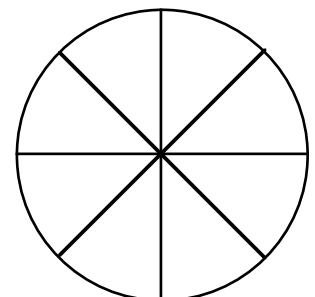

figure 4

**Show this to your teacher.**