



1. Tom plays all day in the mud and dirt.

He plays so hard it is just like work.

He plays with his large red truck, He plays with his little, blue car. He plays all day out in the park.



2. My bird may bite you: my bird is mean.

My bird may bite you and make you scream.

I do not think you should play with my bird, maybe you will get hurt.

1. Is the person that plays in the park a boy or girl?

2. List the things that Tom plays with

3. Write a pair of rhyming words from text 2.

4. Why might the bird make you scream?

5. Draw and colour the toys from text 1.

The Great Fire of London

1 More and 1 Less

I can find one more and one less of a number to ten.

Look at the numbers on the burning houses. Write the numbers that are one more and one less on the buckets to put out the flames.

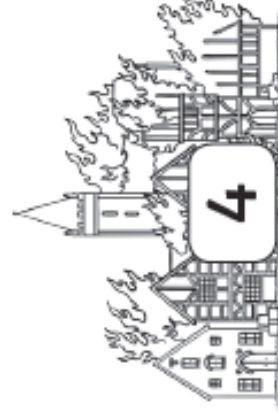
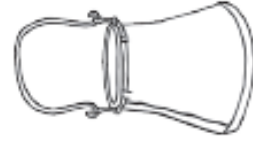
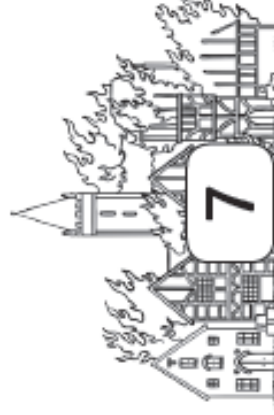
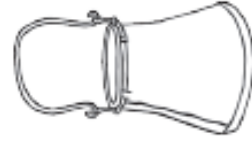
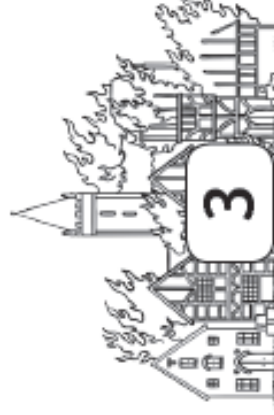
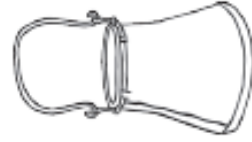
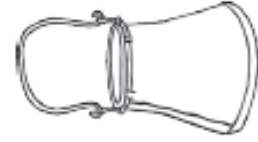

Extra challenge: Colour all the even numbers in one colour and colour all the odd numbers in a different colour.



visit [twinkl.com](https://www.twinkl.com)











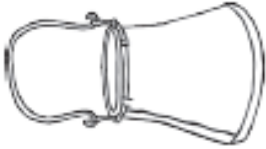

MILD

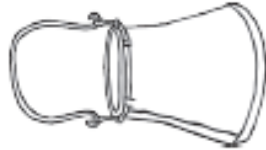
The Great Fire of London

1 More and 1 Less

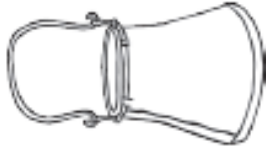
I can find one more and one less of a number to twenty.

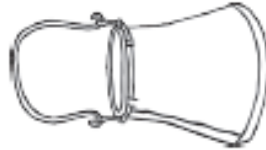
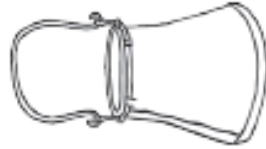
Look at the numbers on the burning houses. Write the numbers that are one more and one less on the buckets to put out the flames.

Extra challenge: Colour all the even numbers in one colour and colour all the odd numbers in a different colour.

The Great Fire of London

1 More and 1 Less

I can find one more and one less of a number to fifty.

Look at the numbers on the burning houses. Write the numbers that are one more and one less on the buckets to put out the flames.

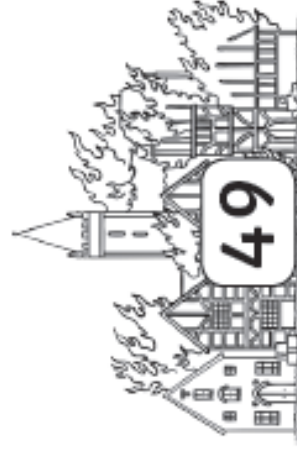
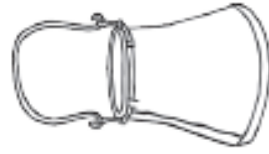
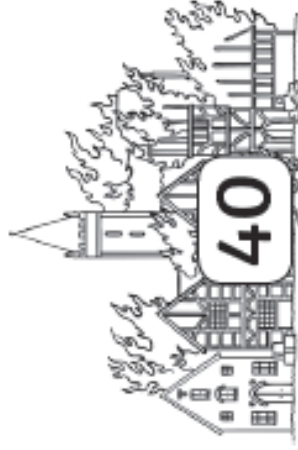
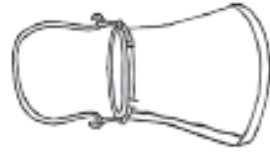

Extra challenge: Colour all the even numbers in one colour and colour all the odd numbers in a different colour.



HOT

visit [twinkl.com](https://www.twinkl.com)





LITERACY

Comprehension (understanding of texts)

Today we are going to work on our understanding and listening skills. We have tried a few of these types of activities in class and they are very important.

I have attached two short rhyming stories and I would like you to have a go at answering the questions. You can either do this orally and if parents could make a note of answers or you could have a go at writing your answers using your sounds!

Have fun and listen carefully 😊



NUMERACY!

1 less

Today I would like us to look at the number word before (NWB) and the number word after (NWA) certain numbers.

As a warm up, use your numeral cards to pick a random card and say the NWB and the NWA! Then you can pick one of the levels below!

Mild: numbers to 10

Spicy: numbers to 20

Hot: numbers to 50

Extension: Write out or colour in the odd and even numbers.



Other



Are you getting at least 60 minutes (one hour) of physical fitness EVERY day? I wonder if you would be able to make a chart for every day this week to track what activities you do!

Weekly Reading:

Please find your weekly reading book allocated on Active Learn! It will be one of the following:

The Fox Twins

Cookies

Get Up and Go!

Sid and Duck

P1 Activities 01/06/20

A note from your teacher

Please complete these tasks in the jotter provided each day.