

# S1 Revision Assessment 2



---

3<sup>rd</sup> Level

## Simplifying Expressions

---

Question 1: Simplify each of the following

- (a)  $y + y + y + y$       (b)  $w + w + w + w + w$       (c)  $a + a + a + a + a + a$       (d)  $s + s + s$   
(e)  $n + n$       (f)  $g + g + g + g - g$       (g)  $y + y + y + y - y - y$       (h)  $p + p - p - p$   
(i)  $3y + 2y$       (j)  $4a + 3a$       (k)  $9k + 5k$       (l)  $7m + m$   
(m)  $15c + 20c$       (n)  $6w - 3w$       (o)  $10y + 3y - 5y$       (p)  $20t - 14t$   
(q)  $7x - 3x - x$       (r)  $8k - 8k$       (s)  $7y - 2y + y$       (t)  $5u - 4u$   
(u)  $y^2 + y^2$       (v)  $a^2 + a^2 + a^2$       (w)  $c^2 + c^2 + c^2 + c^2 + c^2$       (x)  $7y^2 + 3y^2$   
(y)  $2w^2 + 4w^2 + 8w^2$       (z)  $6y^2 - 2y^2 + 3y^2$



Scan here

Question 2: Simplify the following expressions

- (a)  $4u - 6u$       (b)  $8w - 9w$       (c)  $4a + 2a - 9a$       (d)  $2y - 9y$   
(e)  $-3g - 2g$       (f)  $-4f + 9f$       (g)  $-m - 7m$       (h)  $5y^2 - 7y^2$   
(i)  $6a^2 + 2a^2 - 9a^2$       (j)  $ab + ab + ab$

Question 3: Simplify the following expressions

- (a)  $3a + 2b + 4a + b$       (b)  $7y + 5y + 2h + 2h$       (c)  $g + 8a + 2a + g$   
(d)  $7m + 7p + 8m + p + 2p$       (e)  $9e + 2 + e + 2$       (f)  $4 + 3a + 2a + 8$   
(g)  $2y + 4 + 3y - 1$       (h)  $8 + 3w - w - 3$       (i)  $5 - 4s - 2 + 10s$   
(j)  $3x + 6y + 5x - 2y$       (k)  $6m - 2s + 11s + m$       (l)  $2a + 3b - 2 + a + 3b + 4$   
(m)  $3a - 2b + a - 5b$       (n)  $2x - 2y - 6x + 5y$       (o)  $y - 4m - 3y - 5m$   
(p)  $7p - 2q - q + 3r + 4r$       (q)  $11c + 8d - 6c - 11d$

## Multiplying and dividing algebraic terms

---

Question 1: Simplify the following expressions.

- (a)  $3 \times y$       (b)  $w \times 3$       (c)  $7 \times x$       (d)  $a \times 4$   
(e)  $a \times c$       (f)  $f \times g$       (g)  $h \times d$       (h)  $a \times y \times m$   
(i)  $t \times t$       (j)  $p \times p$       (k)  $a \times a \times a$       (l)  $m \times m \times m$



Scan here

Question 1: Simplify the following expressions.

- (a)  $12x \div 2$       (b)  $9y \div 3$       (c)  $15a \div 5$       (d)  $28c \div 7$   
(e)  $8m \div 2m$       (f)  $10c \div 2c$       (g)  $18d \div 3d$       (h)  $35m \div 5m$



Scan here

Question 2: Simplify the following expressions.

- (a)  $\frac{14c}{2}$       (b)  $\frac{56w}{7}$       (c)  $\frac{45a}{9a}$       (d)  $\frac{105y}{5y}$

## Substitution

---

Question 3: If  $a = -2$     $b = 5$     $c = -6$     $d = 10$    and    $e = 9$   
Find the value of each expression.

- (a)  $a + 4$       (b)  $b - 8$       (c)  $c + e$       (d)  $a - d$   
(e)  $d - c$       (f)  $2c$       (g)  $7a$       (h)  $-7b$   
(i)  $2d + 3c$       (j)  $6e + 3a$       (k)  $5a + 7$       (l)  $20 + 4a$   
(m)  $ac$       (n)  $40 - d$       (o)  $2e - a$       (p)  $bd + a$   
(q)  $\frac{a}{2}$       (r)  $\frac{d}{4}$       (s)  $\sqrt{e}$       (t)  $c^2$



Scan here

## Solving Equations

---

Question 1: Solve the following equations

- (a)  $w + 5 = 7$       (b)  $c + 2 = 10$       (c)  $a - 1 = 6$       (d)  $x - 4 = 5$   
(e)  $x + 4 = 13$       (f)  $3w = 12$       (g)  $2x = 18$       (h)  $\frac{w}{2} = 6$   
(i)  $\frac{x}{4} = 7$       (j)  $5y = 30$       (k)  $x + 10 = 40$       (l)  $2x = 34$   
(m)  $x - 9 = 7$       (n)  $\frac{m}{6} = 8$       (o)  $w - 15 = 35$       (p)  $\frac{x}{10} = 5$   
(q)  $11y = 55$       (r)  $2x = 11$       (s)  $b + 6 = 4$       (t)  $\frac{x}{3} = 1.5$   
(u)  $4y = 10$       (v)  $10g = 37$       (w)  $a - 7 = -3$       (x)  $v + 2 = -6$   
(y)  $\frac{w}{4} = 2.7$       (z)  $5y = 24$



Scan here

Question 2 Solve the following equations

(a)  $2x + 3 = 9$

(b)  $3w - 1 = 14$

(c)  $7y + 2 = 30$

(d)  $5x + 20 = 35$

(e)  $6c - 12 = 48$

(f)  $8m - 4 = 20$

(g)  $7w + 13 = 90$

(h)  $12p - 18 = 30$

(i)  $9w - 5 = 67$

(j)  $10a + 40 = 100$

(k)  $9x - 24 = 84$

(l)  $7w + 1 = 1$

(m)  $6x - 19 = 5$

(n)  $3w + 4 = 43$

(o)  $\frac{x}{3} + 1 = 5$

(p)  $\frac{c}{2} - 4 = 6$

(q)  $\frac{x}{10} + 3 = 9$

(r)  $\frac{n}{9} - 8 = 1$

### Converting units of measurement

---

Question 1: Convert the following lengths into centimetres (cm)

(a) 4 m

(b) 9 m

(c) 12 m

(d) 59 m

(e) 750 m

(f) 105 m

(g) 2.5 m

(h) 8.2 m

(i) 1.53 m

(j) 0.6 m

(k) 0.38 m

(l) 0.03 m

Question 2: Convert the following lengths into metres (m)

(a) 300 cm

(b) 700 cm

(c) 900 cm

(d) 1400 cm

(e) 250 cm

(f) 740 cm

(g) 1000 cm

(h) 348 cm

(i) 80 cm

(j) 70 cm

(k) 53 cm

(l) 2 cm

Question 3: Convert the following lengths into centimetres (cm)

(a) 60 mm

(b) 30 mm

(c) 65 mm

(d) 87 mm

(e) 280 mm

(f) 812 mm

(g) 2030 mm

(h) 9000 mm

(i) 7 mm

(j) 4 mm

(k) 1.3 mm

(l) 0.6 mm

Question 4: Convert the following lengths into millimetres (mm)

(a) 2 cm

(b) 6 cm

(c) 4.5 cm

(d) 9.2 cm

(e) 13 cm

(f) 78 cm

(g) 124 cm

(h) 520 cm

(i) 0.5 cm

(j) 0.2 cm

(k) 0.8 cm

(l) 0.16 cm



Scan here

# Area

Question 1: Calculate the area of each of these rectangles

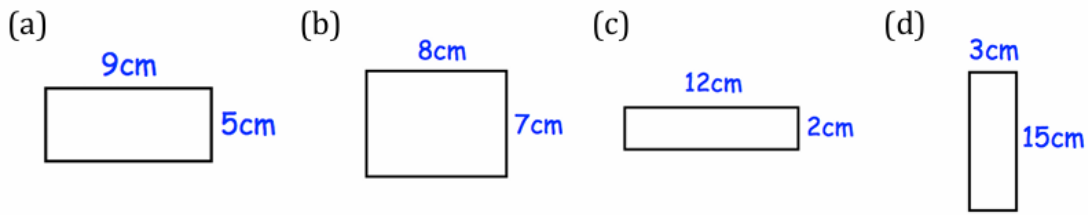

Scan here

Question 2: Work out the area of each of these squares

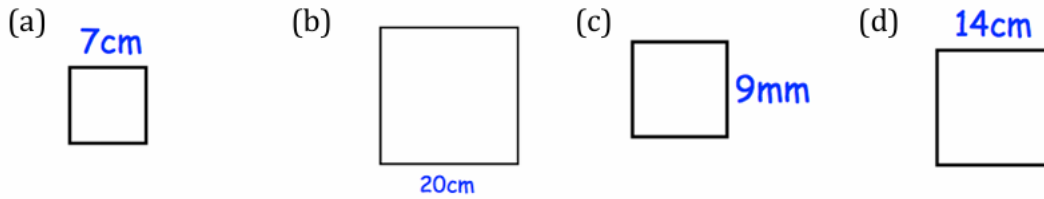

Question 1: Find the area of each triangle.

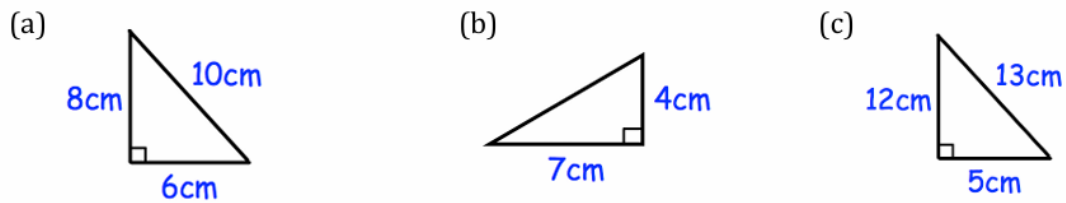

Scan here

Question 3: Find the area of each triangle.

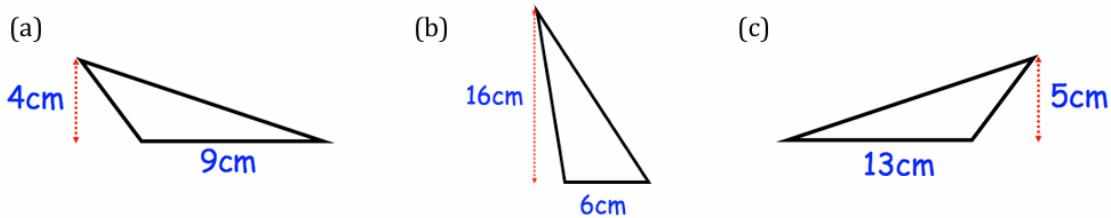

Question 1: Work out the area of each of these shapes.

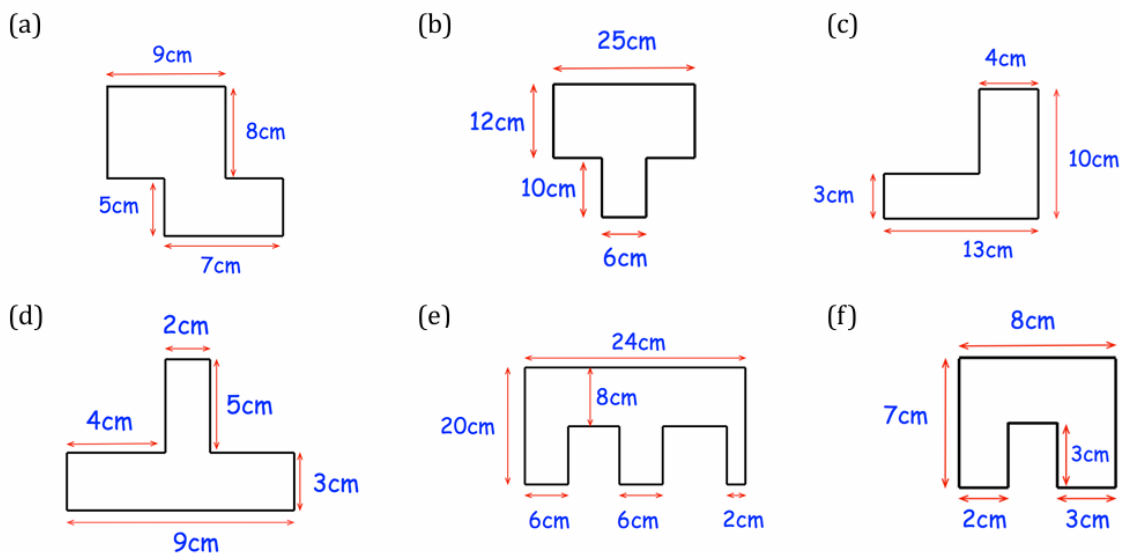

Scan here

# Volume

Question 1: Work out the volume of each cuboid.  
Include suitable units.



Scan here

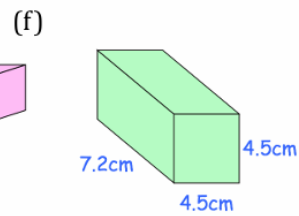
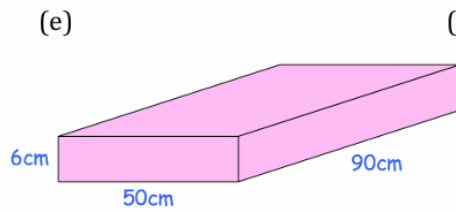
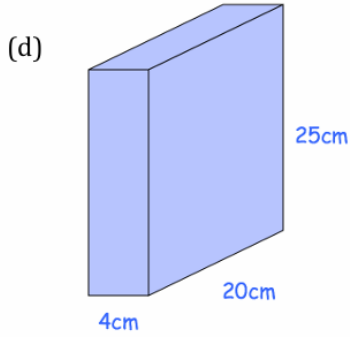
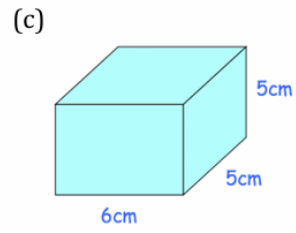
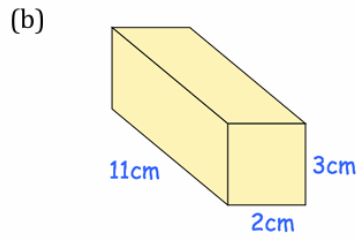
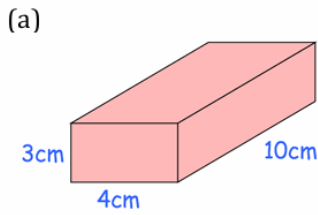

Question 3: Find the length of each cuboid.

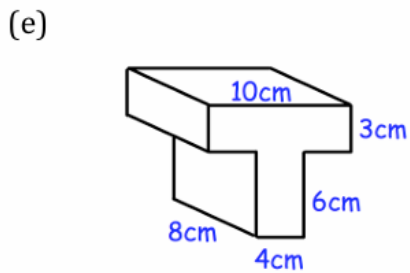
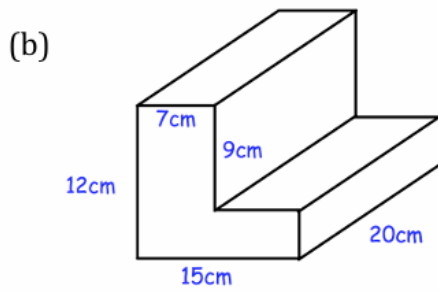
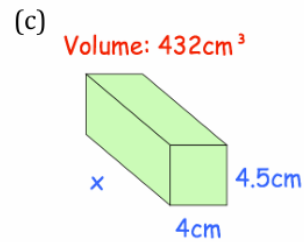
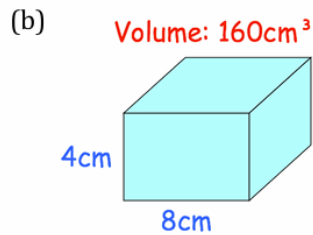
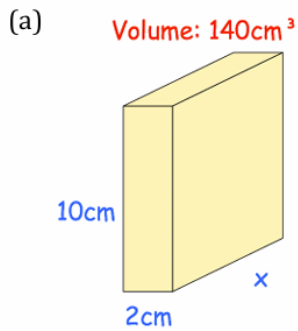

## Coordinates

Question 1: Write down the coordinates of the points A, B, C, D, E, F, G and H.



Scan here

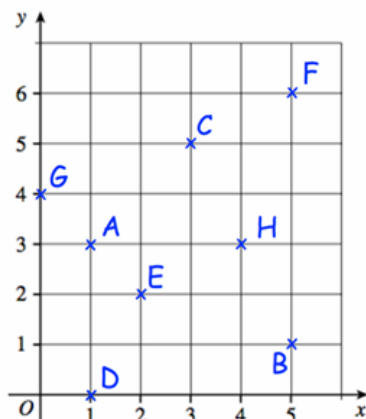

Question 2: Make a copy of the grid shown and then plot the points:

- (a) A (3, 1)
- (b) B (2, 5)
- (c) C (5, 4)
- (d) D (1, 1)
- (e) E (4, 0)
- (f) F (0, 1)
- (g) G (3, 3)
- (h) H (0, 0)

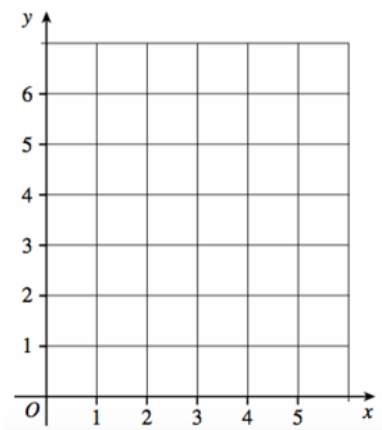

Question 3: Write down the coordinates of the points A, B, C, D, E, F, G and H.

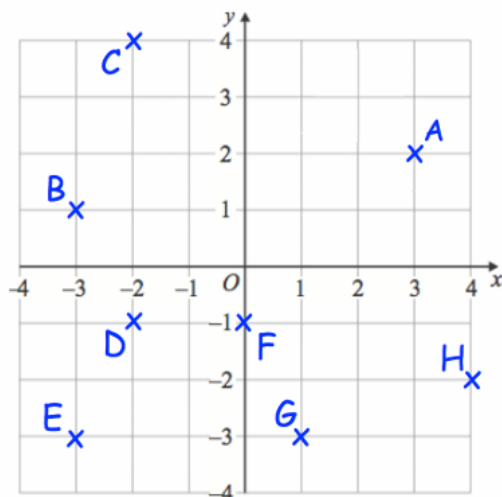

© CORBETTMATHS 2018

Question 1: Three points are shown on a grid.  
ABCD is a rectangle.

- (a) Plot D
- (b) Write down the coordinates of the point D

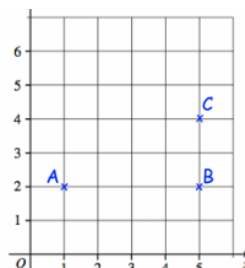

# Angles

Question 1: Write down if each angle below is acute, obtuse or reflex.

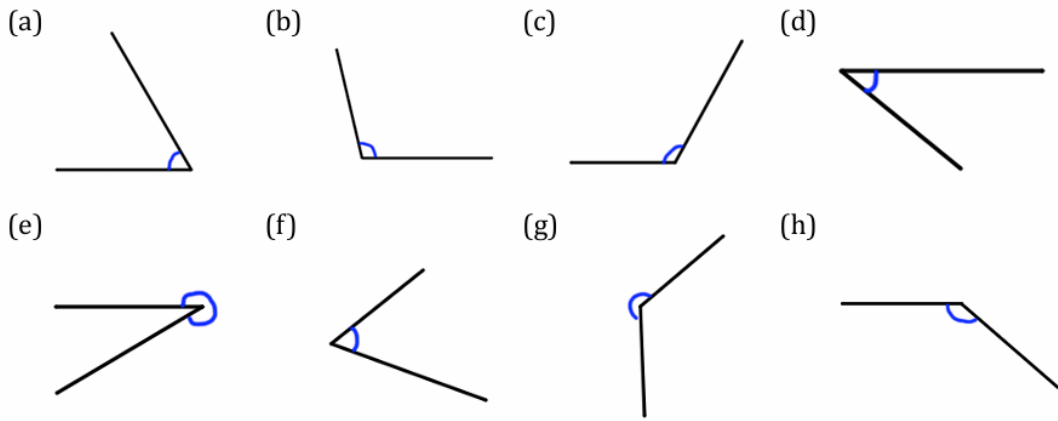

Scan here

Question 1: Find the size of each missing angle.

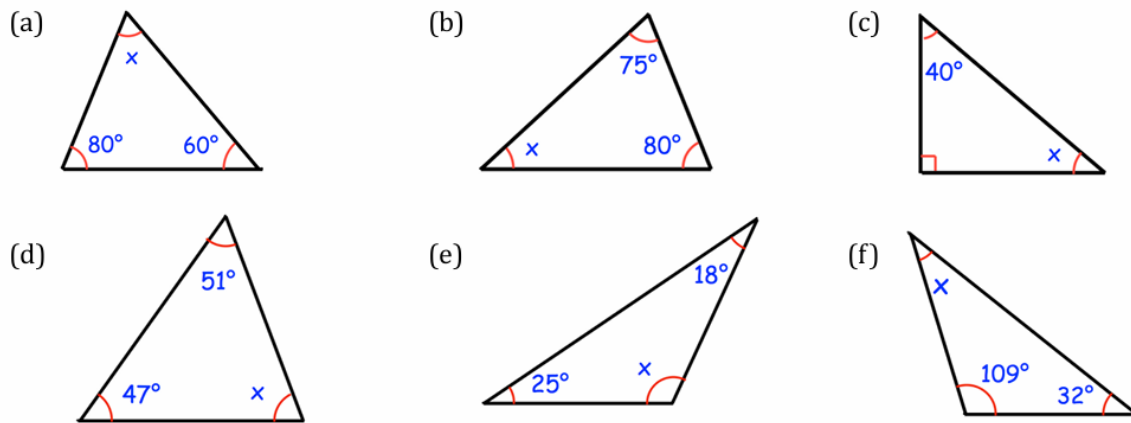

Scan here

Question 1: Calculate the size of the missing angles

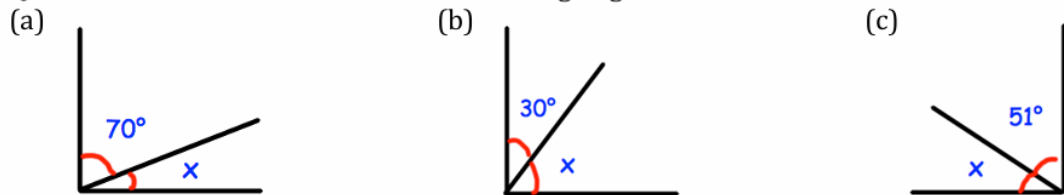

Scan here

Question 2: Calculate the size of the missing angles

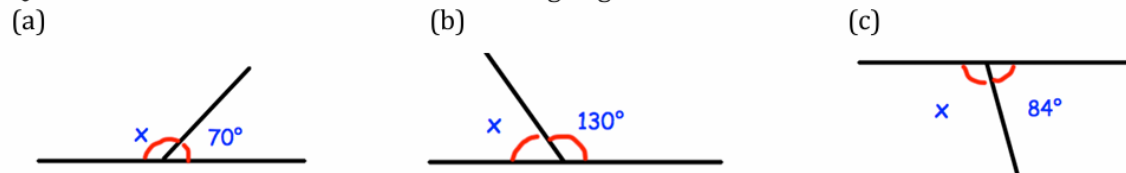

Question 3: Calculate the size of the missing angles

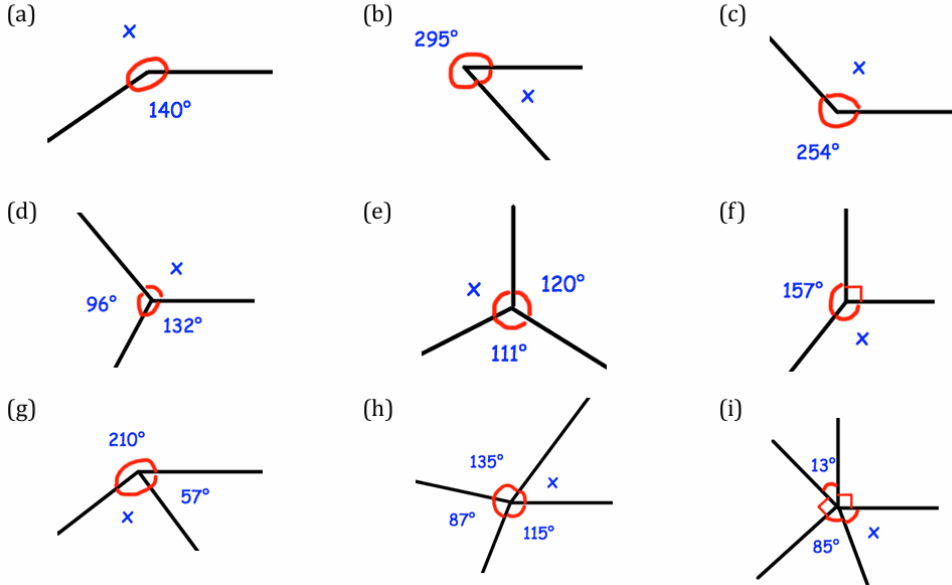

Question 4: Find the angle  $x$  in each question below.  
Give reasons for your answer.

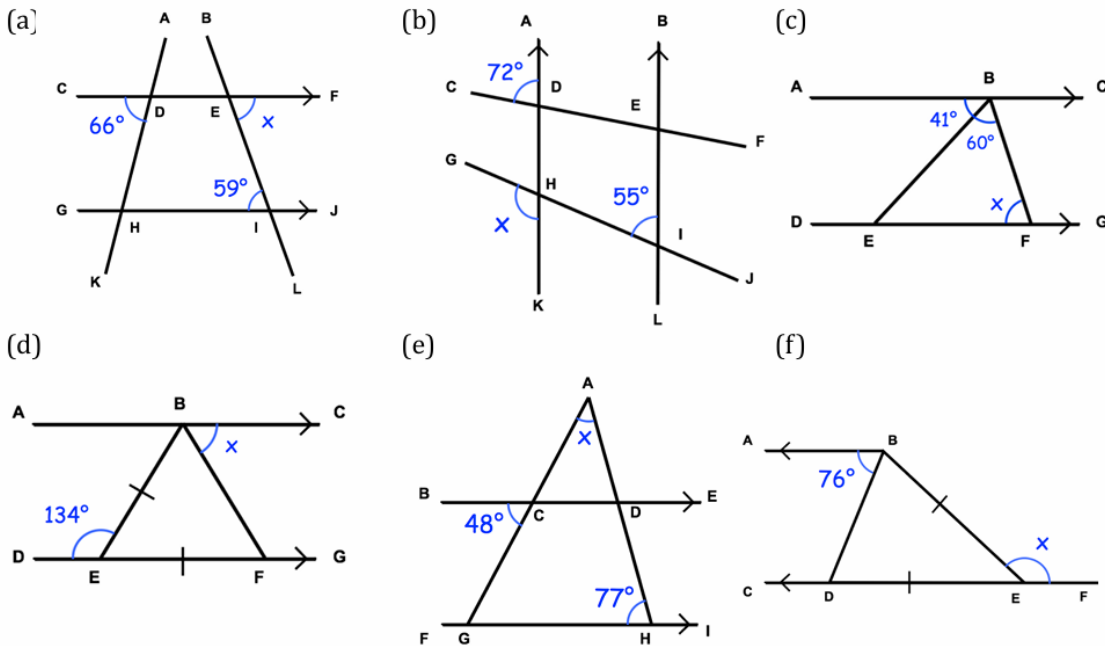

Scan here

## Symmetry

Copy and complete the diagrams to complete each symmetrical pattern:

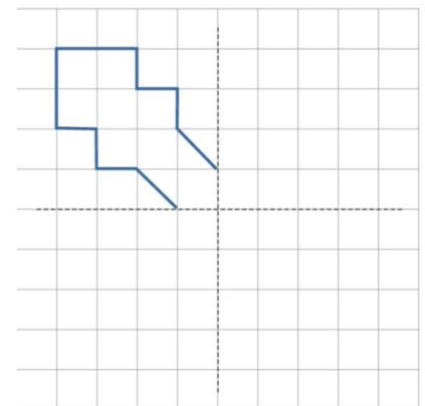
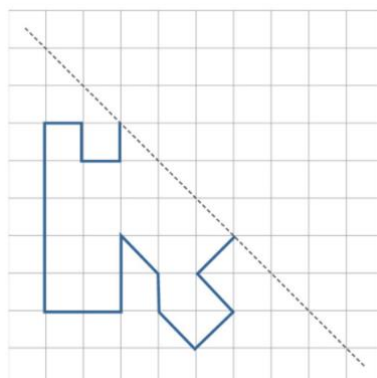
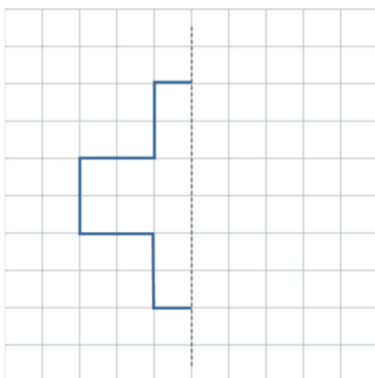

## Answers

### Simplifying Expressions

Question 1

- (a)  $4y$       (b)  $5w$       (c)  $6a$       (d)  $3s$       (e)  $2n$   
(f)  $3g$       (g)  $2y$       (h)  $0$       (i)  $5y$       (j)  $7a$   
(k)  $14k$       (l)  $8m$       (m)  $35c$       (n)  $3w$       (o)  $8y$   
(p)  $6t$       (q)  $3x$       (r)  $0$       (s)  $6y$       (t)  $u$   
(u)  $2y^2$       (v)  $3a^2$       (w)  $5c^2$       (x)  $10y^2$       (y)  $14w^2$   
(z)  $7y^2$

Question 2

- (a)  $-2u$       (b)  $-w$       (c)  $-3a$       (d)  $-7y$       (e)  $-5g$   
(f)  $5f$       (g)  $-8m$       (h)  $-2y^2$       (i)  $-a^2$       (j)  $3ab$

Question 3:

- (a)  $7a + 3b$       (b)  $12y + 4h$       (c)  $10a + 2g$       (d)  $15m + 10p$   
(e)  $10e + 4$       (f)  $5a + 12$       (g)  $5y + 3$       (h)  $2w + 5$   
(i)  $3 + 6s$       (j)  $8x + 4y$       (k)  $7m + 9s$       (l)  $3a + 6b + 2$   
(m)  $4a - 7b$       (n)  $3y - 4x$       (o)  $-2y - 9m$       (p)  $7p - 3q + 7r$   
(q)  $5c - 3d$

### Multiplying and dividing algebraic terms

Question 1:

- (a)  $3y$       (b)  $3w$       (c)  $7x$       (d)  $4a$   
(e)  $ac$       (f)  $fg$       (g)  $dh$       (h)  $amy$   
(i)  $t^2$       (j)  $p^2$       (k)  $a^3$       (l)  $m^3$

Question 1:

- (a)  $6x$       (b)  $3y$       (c)  $3a$       (d)  $4c$       (e)  $4$       (f)  $5$   
(g)  $6$       (h)  $7$

Question 2:

- (a)  $7c$       (b)  $8w$       (c)  $5$       (d)  $21$

### Substitution

Question 3:

- (a)  $2$       (b)  $-3$       (c)  $3$       (d)  $-12$   
(e)  $16$       (f)  $-12$       (g)  $-14$       (h)  $-35$   
(i)  $2$       (j)  $48$       (k)  $-3$       (l)  $12$   
(m)  $12$       (n)  $30$       (o)  $20$       (p)  $48$   
(q)  $-1$       (r)  $2.5$       (s)  $3$       (t)  $36$

## Solving Equations

### Question 1

- (a)  $w = 2$       (b)  $c = 8$       (c)  $a = 7$   
(d)  $x = 9$       (e)  $x = 9$       (f)  $w = 4$   
(g)  $x = 9$       (h)  $w = 12$       (i)  $x = 28$   
(j)  $y = 6$       (k)  $x = 30$       (l)  $x = 17$   
(m)  $x = 16$       (n)  $m = 48$       (o)  $w = 50$   
(p)  $x = 50$       (q)  $y = 5$       (r)  $x = 5.5$   
(s)  $b = -2$       (t)  $x = 4.5$       (u)  $y = 2.5$   
(v)  $g = 3.7$       (w)  $a = 4$       (x)  $v = -8$   
(y)  $w = 10.8$       (z)  $y = 4.8$

### Question 2

- (a)  $x = 3$       (b)  $w = 5$       (c)  $y = 4$   
(d)  $x = 3$       (e)  $c = 10$       (f)  $m = 3$   
(g)  $w = 11$       (h)  $p = 4$       (i)  $I = 8$   
(j)  $a = 6$       (k)  $x = 12$       (l)  $w = 0$   
(m)  $x = 4$       (n)  $w = 13$       (o)  $x = 12$   
(p)  $c = 20$       (q)  $x = 60$       (r)  $n = 81$   
(s)  $x = 84$       (t)  $c = 96$       (u)  $x = 225$

## Converting units

Question 1: Convert the following lengths into centimetres (cm)

- (a) 4 m  $400\text{cm}$     (b) 9 m  $900\text{cm}$     (c) 12 m  $1200\text{cm}$     (d) 59 m  $5900\text{cm}$   
(e) 750 m  $75000\text{cm}$     (f) 105 m  $10500\text{cm}$     (g) 2.5 m  $250\text{cm}$     (h) 8.2 m  $820\text{cm}$   
(i) 1.53 m  $153\text{cm}$     (j) 0.6 m  $60\text{cm}$     (k) 0.38 m  $38\text{cm}$     (l) 0.03 m  $3\text{cm}$

Question 2: Convert the following lengths into metres (m)

- (a) 300 cm  $3\text{m}$     (b) 700 cm  $7\text{m}$     (c) 900 cm  $9\text{m}$     (d) 1400 cm  $14\text{m}$   
(e) 250 cm  $2.5\text{m}$     (f) 740 cm  $7.4\text{m}$     (g) 1000 cm  $10\text{m}$     (h) 348 cm  $3.48\text{m}$   
(i) 80 cm  $0.8\text{m}$     (j) 70 cm  $0.7\text{m}$     (k) 53 cm  $0.53\text{m}$     (l) 2 cm  $0.02\text{m}$

Question 3: Convert the following lengths into centimetres (cm)

- (a) 60 mm  $6\text{cm}$     (b) 30 mm  $3\text{cm}$     (c) 65 mm  $6.5\text{cm}$     (d) 87 mm  $8.7\text{cm}$   
(e) 280 mm  $28\text{cm}$     (f) 812 mm  $81.2\text{cm}$     (g) 2030 mm  $203\text{cm}$     (h) 9000 mm  $900\text{cm}$   
(i) 7 mm  $0.7\text{cm}$     (j) 4 mm  $0.4\text{cm}$     (k) 1.3 mm  $0.13\text{cm}$     (l) 0.6 mm  $0.06\text{cm}$

Question 4: Convert the following lengths into millimetres (mm)

- (a) 2 cm  $20\text{mm}$     (b) 6 cm  $60\text{mm}$     (c) 4.5 cm  $45\text{mm}$     (d) 9.2 cm  $92\text{mm}$   
(e) 13 cm  $130\text{mm}$     (f) 78 cm  $780\text{mm}$     (g) 124 cm  $1240\text{mm}$     (h) 520 cm  $5200\text{mm}$   
(i) 0.5 cm  $5\text{mm}$     (j) 0.2 cm  $2\text{mm}$     (k) 0.8 cm  $8\text{mm}$     (l) 0.16 cm  $1.6\text{mm}$

## Area

### Question 1

- (a)  $45\text{cm}^2$       (b)  $56\text{cm}^2$       (c)  $24\text{cm}^2$       (d)  $45\text{cm}^2$

### Question 2

- (a)  $49\text{cm}^2$       (b)  $400\text{cm}^2$       (c)  $81\text{mm}^2$       (d)  $196\text{cm}^2$

### Question 1

- (a)  $24\text{cm}^2$       (b)  $14\text{cm}^2$       (c)  $30\text{cm}^2$

### Question 3

- (a)  $18\text{cm}^2$       (b)  $48\text{cm}^2$       (c)  $32.5\text{cm}^2$

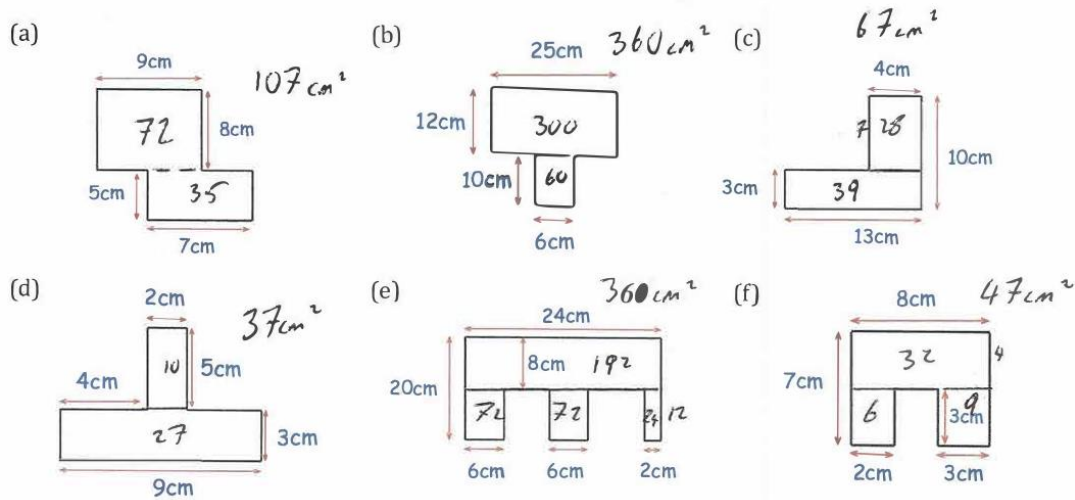

### Volume

- Question 1      Question 3:      (b)  $2160\text{cm}^3$
- (a)  $120\text{cm}^3$       (a)  $7\text{cm}$       (e)  $432\text{cm}^3$
- (b)  $66\text{cm}^3$       (b)  $5\text{cm}$
- (c)  $150\text{cm}^3$       (c)  $24\text{cm}$
- (d)  $2000\text{cm}^3$
- (e)  $27000\text{cm}^3$
- (f)  $145.8\text{cm}^3$

### Coordinates

Question 1: Write down the coordinates of the points A, B, C, D, E, F, G and H.

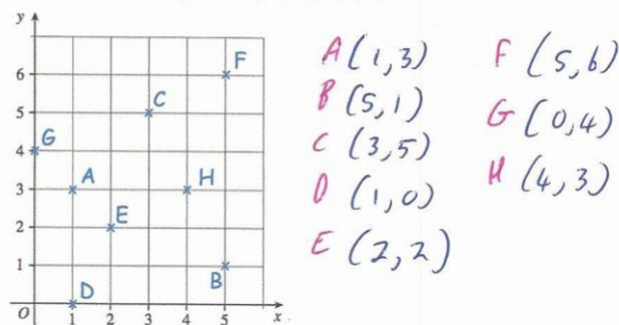

Question 2: Make a copy of the grid shown and then plot the points:

- (a) A (3, 1)  
 (b) B (2, 5)  
 (c) C (5, 4)  
 (d) D (1, 1)  
 (e) E (4, 0)  
 (f) F (0, 1)  
 (g) G (3, 3)  
 (h) H (0, 0)

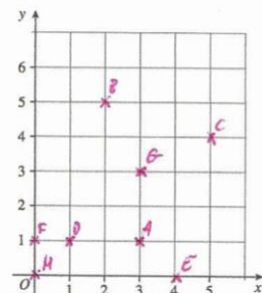

Question 3: Write down the coordinates of the points A, B, C, D, E, F, G and H.

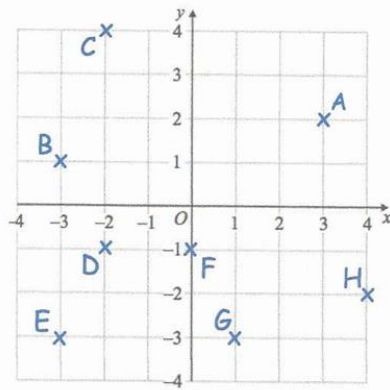

- $A(3, 2)$        $F(0, -1)$   
 $B(-3, 1)$        $G(1, -3)$   
 $C(-2, 4)$        $H(4, -2)$   
 $D(-2, -1)$        $E(-3, -3)$

Question 1: Three points are shown on a grid. ABCD is a rectangle.

- (a) Plot D  
 (b) Write down the coordinates of the point D

$(1, 4)$

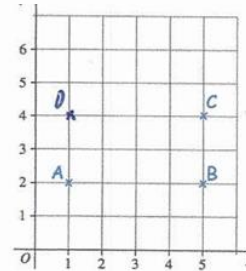

## Angles

Question 1

- (a) Acute                      (b) Obtuse                      (c) Obtuse                      (d) Acute  
 (e) Reflex                      (f) Acute                      (g) Reflex                      (h) Obtuse

Question 1

- (a)  $40^\circ$                       (b)  $25^\circ$                       (c)  $50^\circ$   
 (d)  $82^\circ$                       (e)  $137^\circ$                       (f)  $39^\circ$

Question 1:

- (a)  $20^\circ$                       (b)  $60^\circ$                       (c)  $39^\circ$

Question 2:

- (a)  $110^\circ$                       (b)  $50^\circ$                       (c)  $96^\circ$

Question 3:

- (a)  $220^\circ$                       (b)  $65^\circ$                       (c)  $106^\circ$                       (d)  $132^\circ$   
 (e)  $129^\circ$                       (f)  $113^\circ$                       (g)  $93^\circ$                       (h)  $23^\circ$   
 (i)  $82^\circ$

Question 4:

(a)  $x = 59^\circ$   $\angle HIE = \angle IEF$  as they are alternate angles so are equal.

(b)  $x = 125^\circ$   $\angle EIH = \angle GHD$  as they are corresponding angles so  $\angle GHD = 55^\circ$

$\angle GHD$  and  $\angle GHK$  are in a straight line, so  $\angle GHK = 125^\circ$

(c)  $x = 79^\circ$   $\angle ABE = \angle BEF$  as they are alternate angles so  $\angle BEF = 41^\circ$

BEF is a triangle so the angles add to  $180^\circ$

$\angle BFE = 79^\circ$

(d)  $x = 67^\circ$   $\angle DEB$  and  $\angle BEF$  are in a straight line so  $\angle BEF = 46^\circ$

Triangle EBF is isosceles so  $\angle EFB = 67^\circ$

$\angle EFB = \angle FBC$  as they are alternate angles

(e)  $x = 55^\circ$   $\angle BCG = \angle CGH$  as they are alternate angles,  $\angle CGH = 48^\circ$

AGH is a triangle so the angles add up to  $180^\circ$

$\angle GAH = 55^\circ$

(f)  $x = 152^\circ$   $\angle ABD = \angle BDE$  as they are alternate angles,  $\angle BDE = 76^\circ$

Triangle BDE is isosceles, so  $\angle BED = 28^\circ$

$\angle BED$  and  $\angle BEF$  are in a straight line, so add to  $180^\circ$

## Symmetry

