

CFE National 5 - Pack 1

Unit : Expressions & Formulae (EF)

WORKSHEETS



- ❖ Worksheets covering all the unit topics
- ❖ + Answers

1.1 Working with surds

- Simplification
- Rationalising denominators

1.2 Simplifying expressions

- Multiplication and division using positive and negative indices including fractions
- Calculations using Scientific Notation

1.3 Rounding to a given number of significant figures**2.1 Working with algebraic expressions with brackets**

- $a(bx + c) + d(ex + f)$
- $(ax + b)(cx + d)$
- $ax(bx + c)$
- $(ax + b)(cx^2 + dx + e)$ a, b, c, d and e are integers

2.2 Factorising an algebraic expression

- Common factor
- Difference of two squares $x^2 - y^2$; $px^2 - y^2$
- Common factor with difference of two squares
- Trinomials with unitary x^2 coefficient
- Trinomials with non-unitary x^2 coefficient

2.3 Completing the square in a quadratic expression with unitary x^2 coefficient

2.4 Reducing an algebraic expression to its simplest form

➤ a/b where a and b are of the form $(x + p)n$ or $(x + p)(x + q)$

2.5 Applying the four operations to algebraic fractions

➤ $a/b \ c/d$ where a, b, c and d are simple constants or variables

➤ * can be add, subtract, multiply or divide

3.1 Determining the gradient of a straight line given two points

➤ $m = y_2 - y_1 / x_2 - x_1$

3.2 Working with the length of arc and area of a sector of a circle

3.3 Working with the volume of a solid sphere, cone, pyramid

1.1 WORKING with SURDS

1. Express each of the following in its simplest form:

- (a) $\sqrt{8}$ (b) $\sqrt{12}$ (c) $\sqrt{50}$ (d) $\sqrt{20}$ (e) $\sqrt{24}$ (f) $\sqrt{108}$
(g) $\sqrt{60}$ (h) $\sqrt{72}$ (i) $\sqrt{300}$ (j) $\sqrt{27}$ (k) $\sqrt{96}$ (l) $\sqrt{48}$
(m) $\sqrt{45}$ (n) $\sqrt{98}$ (o) $\sqrt{90}$ (p) $\sqrt{18}$ (q) $\sqrt{28}$ (r) $\sqrt{80}$
(s) $\sqrt{32}$ (t) $\sqrt{160}$ (u) $\sqrt{150}$ (v) $\sqrt{44}$ (w) $\sqrt{63}$ (x) $\sqrt{175}$

2. Simplify:

- (a) $5\sqrt{8}$ (b) $3\sqrt{32}$ (c) $5\sqrt{40}$ (d) $2\sqrt{12}$ (e) $4\sqrt{18}$ (f) $3\sqrt{24}$
(g) $3\sqrt{27}$ (h) $10\sqrt{48}$ (i) $2\sqrt{108}$ (j) $3\sqrt{45}$ (k) $2\sqrt{63}$ (l) $4\sqrt{20}$

3. Express each of the following in its simplest form:

- (a) $5\sqrt{2} + 3\sqrt{2}$ (b) $3\sqrt{7} - \sqrt{7}$ (c) $4\sqrt{3} + 2\sqrt{3} - 3\sqrt{3}$
(d) $5\sqrt{6} - 2\sqrt{6} + \sqrt{6}$ (e) $4\sqrt{3} + 5\sqrt{3}$ (f) $8\sqrt{6} - 2\sqrt{6}$
(g) $\sqrt{2} + 2\sqrt{2}$ (h) $3\sqrt{7} - 9\sqrt{7}$ (i) $5\sqrt{10} - 5\sqrt{10}$
(j) $\sqrt{5} + 5\sqrt{5} - 3\sqrt{5}$ (k) $2\sqrt{3} + \sqrt{3} - 5\sqrt{3}$ (l) $5\sqrt{11} + 7\sqrt{11} - \sqrt{11}$

4. Express each of the following in its simplest form:

- (a) $\sqrt{12} + \sqrt{27}$ (b) $\sqrt{32} - \sqrt{8}$ (c) $\sqrt{72} - \sqrt{50}$
(d) $\sqrt{2} + \sqrt{98}$ (e) $\sqrt{80} + \sqrt{20}$ (f) $\sqrt{24} + \sqrt{54}$
(g) $\sqrt{180} - \sqrt{45}$ (h) $\sqrt{1000} - \sqrt{90}$ (i) $\sqrt{50} - \sqrt{8}$
(j) $\sqrt{3} - \sqrt{12}$ (k) $\sqrt{75} + \sqrt{108} - \sqrt{3}$ (l) $\sqrt{5} + \sqrt{20} + \sqrt{80}$
(m) $\sqrt{108} + \sqrt{12}$ (n) $\sqrt{32} - \sqrt{8}$ (o) $\sqrt{72} - \sqrt{50}$
(p) $\sqrt{2} + \sqrt{98}$ (q) $\sqrt{80} + \sqrt{20}$ (r) $\sqrt{24} + \sqrt{54}$
(s) $\sqrt{8} + 5\sqrt{2}$ (t) $3\sqrt{12} + \sqrt{27}$ (u) $3\sqrt{2} + 2\sqrt{8} - \sqrt{18}$

5. Simplify:

(a) $\sqrt{5} \times \sqrt{5}$

(b) $\sqrt{2} \times \sqrt{2}$

(c) $\sqrt{11} \times \sqrt{11}$

(d) $\sqrt{a} \times \sqrt{a}$

(e) $\sqrt{6} \times \sqrt{6}$

(f) $\sqrt{c} \times \sqrt{c}$

(g) $\sqrt{k} \times \sqrt{k}$

(h) $\sqrt{3} \times \sqrt{6}$

(i) $\sqrt{8} \times \sqrt{2}$

(j) $\sqrt{6} \times \sqrt{2}$

(k) $\sqrt{3} \times \sqrt{5}$

(l) $\sqrt{x} \times \sqrt{y}$

(m) $\sqrt{2} \times \sqrt{8}$

(n) $\sqrt{12} \times \sqrt{3}$

(o) $\sqrt{5} \times \sqrt{20}$

(p) $\sqrt{2} \times \sqrt{32}$

(q) $\sqrt{a} \times \sqrt{b}$

(r) $\sqrt{10} \times \sqrt{x}$

(s) $\sqrt{p} \times \sqrt{q}$

(t) $\sqrt{k} \times \sqrt{6}$

(u) $\sqrt{2} \times \sqrt{10}$

(v) $\sqrt{24} \times \sqrt{3}$

(w) $\sqrt{5} \times \sqrt{10}$

(x) $\sqrt{6} \times \sqrt{12}$

(y) $\sqrt{20} \times \sqrt{3}$

(z) $\sqrt{4} \times \sqrt{8}$

6. (a) $3\sqrt{2} \times \sqrt{2}$ (b) $2\sqrt{5} \times 3\sqrt{5}$ (c) $3\sqrt{2} \times 2\sqrt{7}$ (d) $4\sqrt{3} \times 2\sqrt{3}$

(e) $\sqrt{5} \times 3\sqrt{2}$ (f) $2\sqrt{6} \times 3\sqrt{3}$ (g) $8\sqrt{2} \times \sqrt{12}$ (h) $5\sqrt{3} \times 3\sqrt{5}$

7. Simplify:

(a) $\frac{\sqrt{8}}{\sqrt{2}}$

(b) $\frac{\sqrt{27}}{\sqrt{12}}$

(c) $\frac{\sqrt{2}}{\sqrt{32}}$

(d) $\frac{\sqrt{3}}{\sqrt{27}}$

(e) $\frac{\sqrt{20}}{\sqrt{5}}$

(f) $\frac{\sqrt{12}}{\sqrt{48}}$

(g) $\frac{\sqrt{54}}{\sqrt{24}}$

(h) $\frac{\sqrt{175}}{\sqrt{63}}$

(i) $\frac{\sqrt{18}}{\sqrt{72}}$

(j) $\frac{\sqrt{6}}{\sqrt{54}}$

(k) $\frac{\sqrt{288}}{\sqrt{8}}$

(l) $\frac{\sqrt{1000}}{\sqrt{90}}$

(m) $\frac{\sqrt{48}}{\sqrt{6}}$

(n) $\frac{\sqrt{3}}{\sqrt{24}}$

(o) $\frac{\sqrt{98}}{\sqrt{7}}$

(p) $\frac{\sqrt{50}}{\sqrt{250}}$

8. Expand and simplify:

(a) $\sqrt{2}(1 - \sqrt{2})$

(b) $\sqrt{3}(\sqrt{3} + 1)$

(c) $\sqrt{5}(\sqrt{5} - 1)$

(d) $\sqrt{2}(5 + \sqrt{2})$

(e) $\sqrt{2}(3 + \sqrt{6})$

(f) $2\sqrt{3}(\sqrt{8} + 1)$

(g) $\sqrt{3}(\sqrt{6} - 2\sqrt{8})$

(h) $\sqrt{5}(\sqrt{5} + 2)$

(i) $4\sqrt{6}(2\sqrt{6} - \sqrt{8})$

(j) $\sqrt{8}(\sqrt{2} + 4)$

(k) $2\sqrt{12}(\sqrt{3} + \sqrt{6})$

(l) $\sqrt{5}(\sqrt{200} + \sqrt{50})$

(m) $\sqrt{3}(\sqrt{2} + 1)$

(n) $\sqrt{2}(\sqrt{8} + \sqrt{2})$

(o) $\sqrt{3}(\sqrt{2} + \sqrt{6})$

(p) $\sqrt{5}(3 - \sqrt{5})$

9. Expand and simplify where possible:

(a) $(\sqrt{2} + 3)(\sqrt{2} - 1)$

(b) $(\sqrt{5} + 1)(2\sqrt{5} - 4)$

(c) $(2\sqrt{2} + 3)(\sqrt{2} + 4)$

(d) $(\sqrt{3} + 1)(\sqrt{3} - 1)$

(e) $(2 + \sqrt{5})(2 - \sqrt{5})$

(f) $(\sqrt{3} + \sqrt{2})(\sqrt{3} - \sqrt{2})$

(g) $(\sqrt{2} - 4)(3\sqrt{2} - 1)$

(h) $(\sqrt{8} + 2)(\sqrt{8} + 1)$

(i) $(2\sqrt{3} + \sqrt{2})(\sqrt{3} + 3\sqrt{2})$

(j) $(\sqrt{2} + 3)^2$

(k) $(\sqrt{2} + \sqrt{3})^2$

(l) $(2\sqrt{3} - 1)^2$

(m) $(2\sqrt{7} - \sqrt{2})^2$

(n) $(5 - 2\sqrt{3})^2$

(o) $(\sqrt{3} + \sqrt{5})(\sqrt{3} - \sqrt{5})$

(p) $(\sqrt{7} + 1)^2$

(q) $(\sqrt{6} + \sqrt{2})^2$

(r) $(\sqrt{2} + \sqrt{3})(\sqrt{2} - \sqrt{3})$

10. Express each of the following with a *rational denominator* and simplify where possible:

(a) $\frac{1}{\sqrt{2}}$

(b) $\frac{1}{\sqrt{3}}$

(c) $\frac{1}{\sqrt{5}}$

(d) $\frac{6}{\sqrt{3}}$

(e) $\frac{10}{\sqrt{5}}$

(f) $\frac{2}{\sqrt{3}}$

(g) $\frac{3}{\sqrt{5}}$

(h) $\frac{20}{\sqrt{2}}$

(i) $\frac{2}{\sqrt{2}}$

(j) $\frac{12}{\sqrt{3}}$

(k) $\frac{3}{\sqrt{6}}$

(l) $\frac{4}{\sqrt{5}}$

(m) $\frac{10}{\sqrt{2}}$

(n) $\frac{35}{\sqrt{7}}$

11. Express each of the following with a *rational denominator* and simplify where possible:

(a) $\frac{1}{2\sqrt{5}}$ (b) $\frac{4}{5\sqrt{2}}$ (c) $\frac{3}{3\sqrt{2}}$ (d) $\frac{12}{5\sqrt{6}}$

(e) $\frac{8}{3\sqrt{2}}$ (f) $\frac{20}{7\sqrt{5}}$ (g) $\frac{50}{3\sqrt{10}}$ (h) $\frac{10}{3\sqrt{2}}$

12. Express each of the following in its simplest form with a rational denominator.

(a) $\frac{\sqrt{3}}{\sqrt{2}}$ (b) $\frac{\sqrt{2}}{\sqrt{5}}$ (c) $\frac{\sqrt{8}}{\sqrt{2}}$ (d) $\frac{\sqrt{18}}{\sqrt{3}}$

(e) $\frac{\sqrt{5}}{\sqrt{20}}$ (f) $\frac{\sqrt{2}}{\sqrt{12}}$ (g) $\frac{\sqrt{15}}{\sqrt{5}}$ (h) $\frac{\sqrt{8}}{\sqrt{6}}$

(i) $\frac{\sqrt{5}}{\sqrt{2}}$ (j) $\frac{\sqrt{11}}{\sqrt{2}}$ (k) $\frac{\sqrt{7}}{\sqrt{3}}$ (l) $\frac{\sqrt{13}}{\sqrt{5}}$

(m) $\frac{\sqrt{8}}{3\sqrt{2}}$ (n) $\frac{2\sqrt{3}}{3\sqrt{2}}$ (o) $\frac{5\sqrt{3}}{3\sqrt{5}}$ (p) $\frac{4\sqrt{5}}{5\sqrt{3}}$

(q) $\frac{\sqrt{6}}{\sqrt{18}}$ (r) $\frac{\sqrt{50}}{\sqrt{10}}$ (s) $\sqrt{\frac{3}{12}}$ (l) $\sqrt{\frac{5}{2}}$

13. Express each of the following with a *rational denominator* and simplify where possible:

(a) $\frac{1}{\sqrt{50}}$ (b) $\frac{18}{\sqrt{27}}$ (c) $\frac{5}{\sqrt{50}}$ (d) $\frac{3}{\sqrt{20}}$

(e) $\frac{6}{\sqrt{18}}$ (f) $\frac{2}{\sqrt{8}}$ (g) $\frac{10}{\sqrt{12}}$ (h) $\frac{3}{\sqrt{50}}$

(i) $\frac{4}{\sqrt{32}}$ (j) $\frac{2\sqrt{3}}{\sqrt{54}}$ (k) $\frac{3\sqrt{2}}{\sqrt{24}}$ (l) $\frac{2\sqrt{5}}{\sqrt{45}}$

14. Rationalise the denominator, in each fraction, using the appropriate conjugate surd.

(a)	$\frac{1}{\sqrt{2}-1}$	(b)	$\frac{1}{\sqrt{5}+1}$	(c)	$\frac{12}{2-\sqrt{3}}$	(d)	$\frac{1}{1-\sqrt{2}}$
(e)	$\frac{1}{1+\sqrt{3}}$	(f)	$\frac{3}{\sqrt{5}-1}$	(g)	$\frac{2}{\sqrt{2}+2}$	(h)	$\frac{3}{2-\sqrt{6}}$
(i)	$\frac{5}{3+\sqrt{2}}$	(j)	$\frac{4}{1+\sqrt{3}}$	(k)	$\frac{1}{\sqrt{7}-2}$	(l)	$\frac{1}{\sqrt{3}-\sqrt{2}}$
(m)	$\frac{6}{\sqrt{3}+\sqrt{2}}$	(n)	$\frac{12}{\sqrt{10}-\sqrt{2}}$	(o)	$\frac{3}{\sqrt{5}+\sqrt{6}}$	(p)	$\frac{14}{9-\sqrt{2}}$

SURDS

PROBLEMS

1. A right angled triangle has sides a , b and c as shown.

For each case below calculate the length of the third side, expressing your answer as a surd in its simplest form.

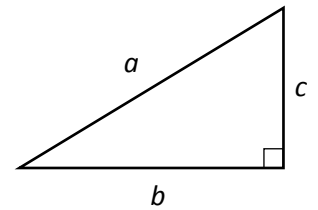

- (a) Find a if $b = 6$ and $c = 3$. (b) Find c if $a = 2$ and $b = 1$.
- (c) Find c if $a = 18$ and $b = 12$ (d) Find b if $a = 2\sqrt{8}$ and $c = 2\sqrt{6}$.
2. Given that $x = 1 + \sqrt{2}$ and $y = 1 - \sqrt{2}$, simplify:
- (a) $5x + 5y$ (b) $2xy$ (c) $x^2 + y^2$ (d) $(x + y)(x - y)$
3. Given that $p = \sqrt{5} + \sqrt{3}$ and $q = \sqrt{5} - \sqrt{3}$, simplify:
- (a) $2p - 2q$ (b) $4pq$ (c) $p^2 - q^2$
4. A rectangle has sides measuring $(2 + \sqrt{2})$ cm and $(2 - \sqrt{2})$ cm.
Calculate the exact value of (a) its area (b) the length of a diagonal.
5. A curve has as its equation $y = 2 + \frac{1}{2}x^2$.
- (a) If the point $P(\sqrt{2}, k)$ lies on this curve find the exact value of k .
- (b) Find the exact length of OP where O is the origin.

6. In $\triangle ABC$, $AB = AC = 12\text{cm}$ and $BC = 8\text{cm}$. Express the length of the altitude from A to BC as a surd in its simplest form. [The line AM in the diagram]

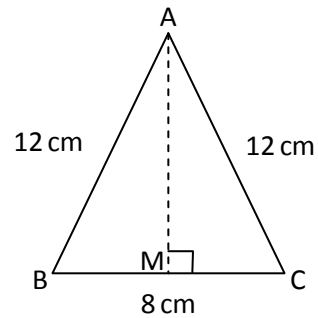

7. An equilateral triangle has each of its sides measuring $2a$ metres.
- (a) Find the exact length of an altitude of the triangle in terms of a .
- (b) Hence find the exact area of the triangle in terms of a .

[Draw a diagram to help you with this question]

8. The exact **area** of a rectangle is $2(\sqrt{6} + \sqrt{3})$ square centimetres. Given that the breadth of the rectangle is $\sqrt{6}$ cm, show that the length is equal to $(2 + \sqrt{2})$ cm.

9. (a challenge) Given that $\tan 75^\circ = \frac{\sqrt{3} + 1}{\sqrt{3} - 1}$, show that $\tan 75^\circ = 2 + \sqrt{3}$.

1.2 INDICES

1. Write each of the following in its simplest index form.

(a) $3^4 \times 3^2$	(b) 2×2^3	(c) $10^5 \times 10^2$	(d) $8^3 \times 8^5$
(e) $7^6 \times 7$	(f) $5^4 \times 5^4$	(g) $9^6 \times 9^2$	(h) $6^8 \times 6^5$
(i) $x^3 \times x^5$	(j) $c^2 \times c^9$	(k) $a^2 \times a^{12}$	(l) $y^5 \times y^5$
(m) $b^{10} \times b^{30}$	(n) $p \times p^9$	(o) $d^2 \times d^4$	(p) $q^{11} \times q^9$
(q) $t^3 \times t^7$	(r) $f^4 \times f^3$	(s) $k \times k^{12}$	(t) $z^{50} \times z^{50}$
(u) $x^{30} \times x^{50}$	(v) $y^{19} \times y$	(w) $a^{25} \times a^{65}$	(x) $b^1 \times b^0$

2. Write each of the following in its simplest index form.

(a) $2^8 \div 2^3$	(b) $5^4 \div 5^2$	(c) $12^9 \div 12^6$	(d) $7^{11} \div 7^4$
(e) $20^5 \div 20$	(f) $8^8 \div 8^4$	(g) $3^{18} \div 3^3$	(h) $4^{15} \div 4^{13}$
(i) $x^7 \div x^2$	(j) $a^9 \div a^5$	(k) $y^{20} \div y^{10}$	(l) $b^4 \div b^1$
(m) $p^{12} \div p^{11}$	(n) $c^7 \div c^7$	(o) $q^8 \div q^2$	(p) $d^4 \div d$
(q) $\frac{x^9}{x^3}$	(r) $\frac{a^8}{a^2}$	(s) $\frac{m^{14}}{m}$	(t) $\frac{s^7}{s^7}$
(u) $\frac{d^{20}}{d^{12}}$	(v) $\frac{y^{100}}{y^{10}}$	(w) $\frac{t^{100}}{t}$	(x) $\frac{w^{10}}{w^0}$

3. Write each of the following in its simplest index form.

(a) $(3^2)^4$	(b) $(8^2)^2$	(c) $(10^3)^2$	(d) $(2^2)^5$
(e) $(4^5)^3$	(f) $(1^7)^2$	(g) $(12^3)^3$	(h) $(5^5)^5$
(i) $(x^4)^2$	(j) $(y^8)^5$	(k) $(a^3)^7$	(l) $(m^4)^4$
(m) $(b^3)^6$	(n) $(p^5)^3$	(o) $(k^5)^{20}$	(p) $(z^6)^0$

4. Write the following without brackets.

- (a) $(2b)^2$ (b) $(7a)^3$ (c) $(3x)^4$ (d) $(2y)^5$
(e) $(ab)^4$ (f) $(xy)^7$ (g) $(wz)^5$ (h) $(st)^3$
(i) $(pq^2)^3$ (j) $(x^4y)^2$ (k) $(a^2b^3)^5$ (l) $(6a^5)^2$
(m) $(10x^2)^3$ (n) $(2c^4)^5$ (o) $(3ab^2)^3$ (p) $(4m^2k)^2$

5. Simplify these expressions.

- (a) $2a^3 \times 5a^5$ (b) $7x \times 9x^8$ (c) $12p^7 \div 4p^4$ (d) $50b^{12} \div 10b^6$
(e) $3y \times (2y^2)^3$ (f) $(4q^3)^2 \times 5q^4$ (g) $(4c^3)^3 \div 8c^2$ (h) $72z^{12} \div (3z^4)^2$
(i) $k^2(k^3 + k^5)$ (j) $m^5(m^2 - m^3)$ (k) $2x^4(x^3 + 3x^2)$ (l) $5a^5(2a^2 - 3a^3)$
(m) $\frac{x^5 \times x^4}{x^6}$ (n) $\frac{(m^5)^4}{m^6}$ (o) $\frac{5c^3 \times 4c^7}{2c^6}$ (p) $\frac{(3q^3)^2 \times 4q^4}{6q^7}$
(q) $\frac{(3xy^5)^3}{9x^2y}$ (r) $\frac{(2a^2b^5)^6}{(4ab)^2}$ (s) $\frac{(4p^4)^3}{2p^3 \times 8p^6}$ (t) $\frac{(2ab^3)^5}{3a^2b \times 4ab^2}$

6. Write down the value of

- (a) 5^0 (b) 2^0 (c) 100^0 (d) $(-3)^0$ (e) 25^0
(f) $\frac{1}{2}^0$ (g) a^0 (h) k^0 (i) $(mn)^0$ (j) $(ab^2)^0$
(k) $(10x^3)^0$ (l) $(16y^2z^3)^0$

7. Rewrite the following with positive indices.

- (a) 3^{-2} (b) 5^{-4} (c) 2^{-6} (d) 10^{-3} (e) 4^{-5} (f) 200^{-7}
(g) a^{-5} (h) x^{-2} (i) p^{-7} (j) y^{-10} (k) $2b^{-3}$ (l) $10q^{-x}$
(m) $\frac{1}{x^{-3}}$ (n) $\frac{1}{w^{-5}}$ (o) $\frac{3}{a^{-2}}$ (p) $\frac{10}{c^{-8}}$ (q) $\frac{2}{3t^{-1}}$ (r) $\frac{5}{4y^{-3}}$

8. Rewrite the following with negative indices.

(a) $\frac{1}{3^2}$ (b) $\frac{1}{6^9}$ (c) $\frac{1}{5^4}$ (d) $\frac{1}{2^7}$ (e) $\frac{1}{10^3}$ (f) $\frac{1}{4^4}$
(g) $\frac{1}{x^3}$ (h) $\frac{1}{a^5}$ (i) $\frac{1}{p^4}$ (j) $\frac{1}{y^{10}}$ (k) $\frac{1}{q^6}$ (l) $\frac{1}{c^8}$

9. Simplify the following expressions.

(a) $m^3 \times m^{-5}$ (b) $x^7 \times x^{-2}$ (c) $p^{-8} \times p^5$ (d) $a^{-3} \times a^{-5}$
(e) $(y^3)^{-4}$ (f) $(c^{-5})^3$ (g) $(q^3)^{-5}$ (h) $(w^{-2})^{-4}$
(i) $4b^{-4} \times 5b^5$ (j) $3x^6 \times 9x^{-6}$ (k) $4k^3 \div 2k^{-2}$ (l) $18d \div 12d^4$
(m) $x^2(x^3 + x^{-1})$ (n) $p^{-3}(p^4 - p^{-8})$ (o) $3a^5(2a + 3a^{-2})$
(p) $\frac{1}{2} m^{-2}(4m^{-3} - 10m^6)$ (q) $\frac{v^3 \times v^5}{v^{-2}}$ (r) $\frac{4h^7 \times 3h^{-4}}{2h^4}$
(s) $\frac{4c^{-5} \times 9c^6}{6c^{-4}}$ (t) $\frac{5x^4 \times 6x^{-8}}{3x^{-4}}$

10. Find the value of

(a) $16^{\frac{1}{4}}$ (b) $8^{\frac{1}{3}}$ (c) $36^{\frac{1}{2}}$ (d) $27^{\frac{2}{3}}$ (e) $64^{\frac{1}{3}}$ (f) $1000^{\frac{1}{3}}$
(g) $25^{\frac{1}{2}}$ (h) $81^{\frac{3}{4}}$ (i) $125^{\frac{2}{3}}$ (j) $64^{\frac{1}{2}}$ (k) $216^{\frac{1}{3}}$ (l) $16^{-\frac{1}{4}}$
(m) $4^{\frac{1}{2}}$ (n) $16^{-\frac{1}{2}}$ (o) $9^{-\frac{1}{2}}$ (p) $27^{-\frac{2}{3}}$ (q) $256^{-\frac{3}{4}}$ (r) $1000^{-\frac{2}{3}}$
(s) $16^{\frac{3}{2}}$ (t) $8^{\frac{4}{3}}$ (u) $8^{\frac{4}{3}}$ (v) $(-8)^{\frac{1}{3}}$ (w) $64^{\frac{2}{3}}$ (x) $100^{-\frac{3}{2}}$
(y) $(\frac{1}{2})^{-1}$ (z) $(\frac{1}{8})^{\frac{4}{3}}$

11. Simplify the following expressions, giving your answers with positive indices.

(a)	$(x^2)^6$	(b)	$(p^3)^6$	(c)	$(a^4)^8$	(d)	$(y^{\frac{2}{3}})^9$
(e)	$(q^{\frac{1}{5}})^{10}$	(f)	$(k^{\frac{2}{5}})^1$	(g)	$(g^4)^{\frac{1}{2}}$	(h)	$(m^{12})^{\frac{2}{3}}$
(i)	$(c^9)^{\frac{2}{3}}$	(j)	$(h^5)^{\frac{1}{2}}$	(k)	$(z^4)^{\frac{3}{4}}$	(l)	$(b^{16})^{\frac{3}{4}}$
(m)	$x^{\frac{1}{2}} \times x^{\frac{1}{2}}$	(n)	$y^{\frac{1}{3}} \times y^{\frac{2}{3}}$	(o)	$d^{\frac{1}{4}} \times d^{\frac{9}{4}}$	(p)	$s^{\frac{7}{2}} \times s^{\frac{1}{2}}$
(q)	$3x^{\frac{1}{2}} \times 4x^{\frac{1}{2}}$	(r)	$6x^{\frac{1}{2}} \times 2x^{\frac{1}{2}}$	(s)	$2x^{\frac{1}{2}} \times 5x^{\frac{1}{2}}$	(t)	$3x^{\frac{2}{3}} \times 2x^{\frac{1}{3}}$
(u)	$x^{\frac{1}{2}} \div x^{\frac{1}{2}}$	(v)	$2x^{\frac{1}{2}} \div x^{\frac{1}{2}}$	(w)	$8x^{\frac{2}{3}} \div 2x^{\frac{1}{3}}$	(x)	$6x^{\frac{1}{3}} \div 4x^{\frac{2}{3}}$

12. Write the following in surd form.

(a)	$x^{\frac{1}{2}}$	(b)	$y^{\frac{1}{3}}$	(c)	$a^{\frac{1}{4}}$	(d)	$y^{\frac{2}{3}}$
(e)	$b^{\frac{3}{4}}$	(f)	$x^{\frac{5}{3}}$	(g)	$c^{\frac{3}{5}}$	(h)	$a^{\frac{4}{5}}$
(i)	$c^{\frac{1}{3}}$	(j)	$z^{\frac{1}{2}}$	(k)	$m^{\frac{2}{3}}$	(l)	$k^{\frac{3}{5}}$
(m)	$p^{\frac{4}{3}}$	(n)	$x^{\frac{5}{3}}$	(o)	$w^{\frac{4}{5}}$	(p)	$d^{\frac{2}{7}}$

13. Write the following in index form.

(a)	\sqrt{x}	(b)	$\sqrt[3]{a}$	(c)	$\sqrt{y^3}$	(d)	$\sqrt[3]{z^2}$
(e)	$\sqrt[3]{c^2}$	(f)	$\sqrt[4]{x^3}$	(g)	$\sqrt[3]{p^5}$	(h)	$\sqrt[5]{m^2}$
(i)	$\frac{1}{\sqrt{a}}$	(j)	$\frac{1}{\sqrt[3]{z}}$	(k)	$\frac{1}{\sqrt[3]{x^4}}$	(l)	$\frac{1}{\sqrt{a^5}}$
(m)	$\frac{1}{\sqrt[3]{b^2}}$	(n)	$\frac{1}{\sqrt[5]{m^3}}$	(o)	$\frac{1}{\sqrt[4]{y}}$	(p)	$\frac{1}{\sqrt[3]{c^5}}$

14. Simplify each of the following by (i) changing root signs to fractional powers;
(ii) moving x 's onto the numerators;
(iii) expanding brackets where necessary.

(a) $x^{\frac{1}{2}}(x^4 + 1)$ (b) $x^{-\frac{1}{2}}(x^{\frac{3}{2}} - x^2)$ (c) $\frac{1}{x^2}(x^{\frac{1}{2}} + x)$

(d) $\frac{2}{x^{-3}}(x^2 + \frac{1}{x})$ (e) $\frac{1}{\sqrt{x}}(x^2 - \sqrt{x})$ (f) $\left(x^2 + \frac{1}{x}\right)^2$

(g) $\frac{1}{x}(\sqrt{x} + x)$ (h) $\left(x + \frac{1}{\sqrt{x}}\right)^2$ (i) $x^{-2}\left(\frac{1}{x} - \sqrt[3]{x}\right)$

(j) $\frac{x^2 + 3}{x}$ (k) $\frac{\sqrt{x} - x}{x^2}$ (l) $\frac{(2x + 1)^2}{x^{\frac{3}{2}}}$

INDICES

EXAM QUESTIONS

1. (a) Simplify $\frac{7a^3b^2}{a\sqrt{b}}$

(b) If $a = -1$ and $b = 4$, find the value of the expression in part (a).

2. Given that $y = 2x^{-\frac{2}{3}}$, find y when $x = 8$.

3. Simplify $x^{\frac{2}{3}}(x^{\frac{2}{3}} + x^{-\frac{2}{3}})$

4. (a) Simplify $\frac{m^5}{m^{-3}}$ (b) Evaluate $125^{-\frac{2}{3}}$

5. Express $\frac{p^5 \times 8p}{2p^{-3}}$ in its simplest form.

6. Simplify, writing your answer with a positive index: $3a^4 \times a^{-6}$

7. Simplify the fraction, giving your answer in positive index form: $\frac{x^3 \times x^4}{x^9}$

8. Simplify $\frac{a^2 \times a^5}{a^{-3}}$.

9. (a) Remove the brackets and simplify: $p^{\frac{1}{2}}(p^{\frac{5}{2}} - 2)$.

(b) Hence, or otherwise, find the value of $p^{\frac{1}{2}}(p^{\frac{5}{2}} - 2)$ when $p = 4$.

1.2 CALCULATIONS USING SCIENTIFIC NOTATION

1. Rewrite these sentences with the numbers written out in full

- (a) The speed of light is 3×10^8 metres per second.
- (b) The diameter of the earth is 1.268×10^4 kilometres.
- (c) A Building Society has $\pounds 2.15 \times 10^9$ in its funds.
- (d) The radius of the orbit of an electron is 5×10^{-8} mm.
- (e) A space probe reached a speed of 1.49×10^5 m.p.h.
- (f) The earth weighs 6.6×10^{21} tonnes.
- (g) A film of oil is 8×10^{-7} mm thick.

2. Use your calculator to answer the following, giving your answers in Standard Form.

- (a) $(2.2 \times 10^5) \times (4 \times 10^6)$
- (b) $(3.15 \times 10^7) \times (2.2 \times 10^8)$
- (c) $(1.8 \times 10^3) \times (2.3 \times 10^4)$
- (d) $(9.1 \times 10^6) \times (1.5 \times 10^{12})$
- (e) $(1.4 \times 10^{13}) \times (4.9 \times 10^{11})$
- (f) $(2.3 \times 10^5) \times (2.4 \times 10^7)$
- (g) $(4.25 \times 10^4) \times (2.8 \times 10^2)$
- (h) $(1.95 \times 10^{-8}) \times (3.2 \times 10^9)$
- (i) $(8.7 \times 10^5) \times (7.3 \times 10^{-10})$
- (j) $(5.05 \times 10^{-21}) \times (1.8 \times 10^{-17})$
- (k) $(2.2 \times 10^{15}) \div (4 \times 10^8)$
- (l) $(3.15 \times 10^4) \div (5 \times 10^{13})$
- (m) $(1.8 \times 10^{23}) \div (2.4 \times 10^7)$
- (n) $(1.302 \times 10^{14}) \div (1.4 \times 10^8)$
- (o) $(1.131 \times 10^{18}) \div (8.7 \times 10^{10})$
- (p) $(8.25 \times 10^5) \div (3.3 \times 10^{-7})$
- (q) $(4.25 \times 10^{-14}) \div (2.5 \times 10^{-5})$
- (r) $(8.82 \times 10^{-22}) \div (6.3 \times 10^{11})$
- (s) $(9.167 \times 10^4) \div (1.03 \times 10^{-4})$
- (t) $(6.846 \times 10^{34}) \div (6.52 \times 10^{15})$
- (u) $\frac{1.28 \times 10^6}{0.4 \times 10^2}$
- (v) $\frac{4.17 \times 10^2}{3 \times 10^{-3}}$
- (w) $\frac{18 \times 10^{-2}}{0.2 \times 10^5}$

3. Answer each of the following questions leaving your answers in standard form.

- (a) Light travels at 1.85×10^5 miles per second. How far will it travel in an hour?
- (b) The radius of the earth is 6.45×10^6 metres. What is its circumference (in km)?
- (c) If a heart beats 70 times a minute, how many times will it beat in a lifetime of 80 years?[Take all years to have 365 days]
- (d) 100 grams of water contains 2000 drops. How many drops would there be in a tank containing 1 tonne of water?
- (e) In 1 gram of carbon there are 6×10^{26} atoms. How many carbon atoms are there in 5kg of pure carbon?

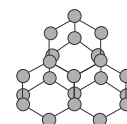

4. Answer each of the following questions leaving your answers in standard form

- (a) The weight of a droplet of water is 8.7×10^{-5} grams. Calculate the weight of 10 000 droplets.
- (b) A space probe can travel at a speed of 3.6×10^6 miles per day. What distance will it travel in a week?
- (c) A biscuit factory produces 6.7×10^6 teacakes every day. How many teacakes were produced in the month of **February 2008**?
- (d) The speed of light is approximately 299 million metres per second. How far can light travel in a minute?
- (e) Last year 1.68×10^6 copies of a DVD were sold on its first day of release. If the cost of one DVD was £12, how much money was collected on that first day?
- (f) In a reality TV show there were 7.9×10^6 calls made to vote for the contestants. If each call cost 24p calculate how much the calls cost in total. Give your answer in pounds.
- (g) There are 8.64×10^4 seconds in one day. How many seconds are there in the month of April?
- (h) Organisers of the London Marathon provide enough water to give each runner 7 litres during the race. If 747 000 runners take part, how many litres of water are provided?
- (i) The exchange rate in Turkey is £1 = 2 670 000 Turkish Lira. Stephen is going on an Adriatic cruise and changes £700 into Turkish Lira. How much will he get in Lira?

SCIENTIFIC NOTATION

EXAM QUESTIONS

1. The distance between the earth and mars is on average approximately 1.65×10^8 miles.



A spaceship has been designed to travel between the earth and mars at an average speed of 20 000 miles per hour.



How many days will the spaceship take to reach mars?

Give your answer correct to the nearest day.

2. Uranium is a radioactive isotope which has a half-life of 4.5×10^9 years. This means that only half of the original mass will be radioactive after 4.5×10^9 years.

How long will it take for the radioactivity of a piece of Uranium to reduce to **one eighth** of its original level? Give your answer in **scientific notation**.

3. The population of Scotland in June 2001 was 5.06×10^6 people.

The population of China in June 2001 was approximately 250 times larger than that of Scotland .

Calculate, correct to three significant figures, the population of China in 2001, expressing your answer in standard form.

4. The Blackbird is a two-seater high speed jet.

In December 1964 it broke a world speed record by travelling at 1.02×10^4 metres per second.



Calculate, correct to three significant figures, the distance travelled if the jet were to maintain this speed for one hour. Express your answer in scientific notation.

1.3 SIGNIFICANT FIGURES

1. Round to 1 significant figure :

- | | | | |
|----------|-----------|----------|------------|
| (a) 23 | (b) 5.5 | (c) 78 | (d) 31 |
| (e) 125 | (f) 309 | (g) 291 | (h) 843.6 |
| (i) 7646 | (j) 1928 | (k) 8003 | (l) 5192.7 |
| (m) 10.9 | (n) 556.2 | (o) 3.98 | (p) 12345 |
| (q) 1.01 | (r) 93 | (s) 0.86 | (t) 606 |

2. Round to 2 significant figures :

- | | | | |
|------------|-------------|-------------|-----------|
| (a) 8.72 | (b) 92.8 | (c) 0.186 | (d) 679 |
| (e) 2.112 | (f) 6.463 | (g) 31.4 | (h) 25.8 |
| (i) 24.27 | (j) 18.76 | (k) 6397 | (l) 4.99 |
| (m) 0.0526 | (n) 0.00613 | (o) 0.08702 | (p) 13814 |
| (q) 2.456 | (r) 45192 | (s) 29.302 | (t) 0.756 |

3. Round to 3 significant figures :

- | | | | |
|---------------|-----------|-------------|---------------|
| (a) 49.32 | (b) 2.345 | (c) 0.5928 | (d) 4765 |
| (e) 6.081 | (f) 24180 | (g) 0.06281 | (h) 29.514 |
| (i) 0.0094682 | (j) 56248 | (k) 0.09803 | (l) 24.47 |
| (m) 28.32 | (n) 2463 | (o) 3174 | (p) 30.03 |
| (q) 2.6759 | (r) 3085 | (s) 2.007 | (t) 0.0003175 |

4. Round 248382 correct to

- | | | | |
|-----------------|-----------------|-----------------|----------------|
| (a) 4 sig. figs | (b) 3 sig. figs | (c) 2 sig. figs | (d) 1 sig. fig |
|-----------------|-----------------|-----------------|----------------|

5. Round 0.0286016 correct to

- | | | | |
|-----------------|-----------------|-----------------|----------------|
| (a) 4 sig. figs | (b) 3 sig. figs | (c) 2 sig. figs | (d) 1 sig. fig |
|-----------------|-----------------|-----------------|----------------|

6. Calculate and give your answer correct to 2 significant figures

- | | | |
|---------------------------------|---------------------------------|----------------------------------|
| (a) 5.16×22.7 | (b) $27.3 \div 6.84$ | (c) 3.14×9^2 |
| (d) $25.8 \times 1.76 \div 1.1$ | (e) 13.2×3.72 | (f) $25.8 \div 52.9$ |
| (g) $1.14^2 \times 2.92$ | (h) $5.2 \times 0.49 \div 30.3$ | (i) $234 \div (0.028 \times 33)$ |
| (j) $(0.08 \times 25^2) \div 3$ | (k) $(1.05)^2 \times 455$ | (l) $3.14 \times 12^2 \div 7$ |

7. Calculate and give your answer correct to 3 significant figures

- | | | |
|----------------------------------|--------------------------------|----------------------------------|
| (a) 2.29×58.1 | (b) $325.9 \div 68.2$ | (c) 3.14×18 |
| (d) 0.08×12349 | (e) $3.7^2 \div 1.56$ | (f) $1001 \div 3$ |
| (g) $12.7 \times (1.24 + 0.321)$ | (h) $0.13 \times 99 \div 0.49$ | (i) $0.77 \div (4.2 \times 1.9)$ |
| (j) $(26.9 - 1.85) \times 13$ | (k) $60 \div 29$ | (l) $11 \times 2.6 \div 30$ |

8. The speed of light is approximately 8×10^5 times faster than the speed of sound in air.

If the speed of sound in air is 372 metres per second, calculate the speed of light.

Give your answer in **scientific notation correct to 3 significant figures**.

2.1 ALGEBRAIC EXPRESSIONS with BRACKETS

1. Multiply out the brackets:

(a) $3(x - 5)$ (b) $5(y + 7)$ (c) $8(a + 6)$ (d) $6(3 + t)$

(e) $x(x + 9)$ (f) $y(3 - y)$ (g) $b(b - 4)$ (h) $p(5 + p)$

(i) $a(b + c)$ (j) $x(x - y)$ (k) $p(q - r)$ (l) $a(a + x)$

2. Expand the brackets:

(a) $4(2a + 5)$ (b) $7(3y - 4)$ (c) $2(12x + 11)$ (d) $9(4c - 7)$

(e) $2a(a + 3)$ (f) $5x(x - 8)$ (g) $10y(3 - y)$ (h) $3t(t + 6)$

(i) $3x(2x - 9)$ (j) $2y(7 - 5y)$ (k) $4b(3b - 8)$ (l) $5x(5x + 4)$

3. Expand and simplify:

(a) $3(3a - 1) + 2a$ (b) $2(5x + 3) - 3x$ (c) $8(b + 2) - 9$

(d) $4(2h - 1) + 7$ (e) $5(3 - 4x) + 11x$ (f) $3(2c + 1) - 8$

(g) $2(4t + 3) - 10t$ (h) $p(p + q) - 3pq$ (i) $7(1 - 3c) - 10$

(j) $3 + 2(2x + 5)$ (k) $7a + 3(2a - 3)$ (l) $5 - 2(2x - 7)$

(m) $6 + 5(3y - 2)$ (n) $9b - 2(4b - 1)$ (o) $8 - 3(5x + 7)$

(p) $12x - 4(4x - 5)$ (q) $3c + 5(1 - 2c)$ (r) $7 - 2(5a - 12)$

4. Multiply out the brackets:

(a) $(x + 2)(x + 3)$ (b) $(y + 5)(y + 2)$ (c) $(a + 4)(a + 6)$

(d) $(b + 3)(b + 4)$ (e) $(x + 9)(x + 5)$ (f) $(s + 3)(s + 8)$

(g) $(y + 7)(y + 4)$ (h) $(b + 3)(b + 3)$ (i) $(c + 6)(c + 7)$

(j) $(a + 8)(a + 4)$ (k) $(y + 4)(y + 2)$ (l) $(x + 9)(x + 8)$

(m) $(p + 12)(p + 7)$ (n) $(c + 5)(c + 6)$ (o) $(t + 7)(t + 9)$

(p) $(x + 4)(x + 9)$ (q) $(y + 12)(y + 5)$ (r) $(a + 11)(a + 9)$

5. Multiply out the brackets:

(a) $(x - 1)(x - 5)$

(b) $(c - 4)(c - 2)$

(c) $(y - 3)(y - 7)$

(d) $(b - 6)(b - 8)$

(e) $(x - 5)(x - 2)$

(f) $(s - 8)(s - 5)$

(g) $(y - 2)(y - 9)$

(h) $(a - 4)(a - 4)$

(i) $(t - 3)(t - 6)$

(j) $(x - 6)(x - 5)$

(k) $(b - 5)(b - 3)$

(l) $(c - 10)(c - 4)$

(m) $(a - 3)(a - 9)$

(n) $(y - 8)(y - 7)$

(o) $(x - 12)(x - 3)$

(p) $(s - 4)(s - 7)$

(q) $(d - 1)(d - 15)$

(r) $(b - 10)(b - 1)$

6. Multiply out the brackets:

(a) $(x - 1)(x + 5)$

(b) $(a + 3)(a - 7)$

(c) $(t - 5)(t + 4)$

(d) $(y + 8)(y - 4)$

(e) $(c + 2)(c - 7)$

(f) $(x - 6)(x + 1)$

(g) $(b - 2)(b + 9)$

(h) $(p - 10)(p + 2)$

(i) $(y - 8)(y + 7)$

(j) $(z + 4)(z - 6)$

(k) $(x + 1)(x - 1)$

(l) $(a + 2)(a - 15)$

(m) $(c - 3)(c + 3)$

(n) $(p - 7)(p + 1)$

(o) $(b + 10)(b - 5)$

7. Multiply out the brackets:

(a) $(x + 3)^2$

(b) $(w - 2)^2$

(c) $(a - 5)^2$

(d) $(c + 8)^2$

(e) $(y - 4)^2$

(f) $(a + 6)^2$

(g) $(b + 1)^2$

(h) $(s + 7)^2$

(i) $(b - 9)^2$

(j) $(x - 10)^2$

(k) $(c - 1)^2$

(l) $(y - 3)^2$

(m) $(2x - 1)^2$

(n) $(5y + 2)^2$

(o) $(3x + 4)^2$

(p) $(4b - 5)^2$

8. Multiply out the brackets:

(a) $(a + b)(c + d)$

(b) $(2 + x)(3 + y)$

(c) $(a + 4)(b + 5)$

(d) $(p - q)(r - s)$

(e) $(1 - a)(7 - b)$

(f) $(c - 6)(d + 8)$

9. Multiply out the brackets:

(a) $x(x^2 + x - 1)$

(b) $3(2x^2 - 3x + 5)$

(c) $x(3x^2 - 5x + 8)$

(d) $2x(x^2 + 2x + 3)$

(e) $-5(x^2 - 8x + 2)$

(f) $x(x^2 - 4x - 7)$

10. Multiply out the brackets and simplify:

(a) $(x + 2)(x^2 + 3x + 1)$

(c) $(x + 1)(x^2 + 5x + 4)$

(e) $(x + 8)(x^2 + 2x + 3)$

(g) $(x + 12)(x^2 + x + 7)$

(i) $(x + 9)(x^2 + 12x + 7)$

(k) $(x + 3)(x^2 - 5x + 2)$

(m) $(x + 2)(x^2 - 8x + 3)$

(o) $(x + 10)(x^2 + 3x - 6)$

(q) $(x + 11)(x^2 + x - 2)$

(b) $(x + 5)(x^2 + 4x + 2)$

(d) $(x + 3)(x^2 + x + 5)$

(f) $(x + 4)(x^2 + 7x + 6)$

(h) $(x + 10)(x^2 + 3x + 9)$

(j) $(x + 7)(x^2 + 9x + 1)$

(l) $(x - 6)(x^2 - x + 11)$

(n) $(x + 5)(x^2 - 6x + 7)$

(p) $(x + 9)(x^2 + 5x - 6)$

(r) $(x + 7)(x^2 + 8x - 3)$

11. Multiply out the brackets and simplify:

(a) $(x - 1)(x^2 + x + 1)$

(c) $(x - 2)(x^2 + 4x + 3)$

(e) $(x - 3)(x^2 - 2x + 5)$

(g) $(x - 4)(x^2 - x + 2)$

(i) $(x - 9)(x^2 + 3x - 2)$

(k) $(x - 8)(x^2 + x - 7)$

(m) $(x - 5)(x^2 - 4x - 1)$

(o) $(x - 6)(x^2 - 7x - 2)$

(b) $(x - 7)(x^2 + 3x + 5)$

(d) $(x - 4)(x^2 + 6x + 1)$

(f) $(x - 6)(x^2 - 5x + 2)$

(h) $(x - 1)(x^2 - 2x + 7)$

(j) $(x - 5)(x^2 + 8x + 6)$

(l) $(x - 3)(x^2 + 9x - 12)$

(n) $(x - 10)(x^2 - 3x - 8)$

(p) $(x - 1)(x^2 - 17x - 13)$

12. Multiply out the brackets and simplify:

(a) $(x + 5)(2x^2 + 4x + 9)$

(c) $(x - 2)(6x^2 - 5x + 7)$

(e) $(x - 4)(5x^2 - x - 8)$

(g) $(2x + 1)(3x^2 + 4x + 1)$

(i) $(5x - 2)(2x^2 + 3x - 7)$

(b) $(x - 3)(5x^2 + x + 6)$

(d) $(x + 7)(3x^2 + 9x - 2)$

(f) $(x + 1)(7x^2 - 2x + 11)$

(h) $(3x + 4)(x^2 - 11x + 2)$

(j) $(4x - 3)(3x^2 - 5x - 4)$

13. Expand and simplify each of the following expressions:

(a) $3(x-4) + (x+2)^2$ **(b)** $(2x-1)(x+3) + 2x(x-3)$

(c) $(2x+3)^2 - 4(x+1)$ **(d)** $-(x+2)^2 + 4x$

(e) $-3(2x-1)^2 + 12x^2$ **(f)** $(x-3)(x+2) - (x+4)^2$

(g) $3x(x-4) - (x+2)(x-4)$ **(h)** $(x+2)^2 + (2x-1)^2 - (x+3)$

(i) $(2x-3)^2 - 4(x-3)(2x+1)$ **(j)** $3x(x+3)^2 + 2x(x-3)$

(k) $2x(x^2 - x + 2) + (x-3)^2$ **(l)** $(x-1)^2 - x(x+1)^2$

2.2 FACTORISING an ALGEBRAIC EXPRESSION

1. Factorise by first finding a common factor:

- | | | | |
|---------------|---------------|-----------------|-----------------|
| (a) $2x + 2y$ | (b) $3c + 3d$ | (c) $6s + 6t$ | (d) $12x + 12y$ |
| (e) $9a + 9b$ | (f) $8b + 8c$ | (g) $5p + 5q$ | (h) $7g + 7h$ |
| (i) $4m + 4n$ | (j) $9e + 9f$ | (k) $13j + 13k$ | (l) $14v + 14w$ |

2. Factorise by finding the common factor:

- | | | | |
|----------------|----------------|----------------|----------------|
| (a) $2x + 4$ | (b) $3d + 9$ | (c) $6s + 3$ | (d) $12x + 4$ |
| (e) $6 + 9a$ | (f) $2b + 8$ | (g) $5y + 10$ | (h) $10 + 15c$ |
| (i) $12x + 16$ | (j) $18m + 24$ | (k) $30 + 36a$ | (l) $14y + 21$ |

3. Factorise by finding the common factor:

- | | | | |
|----------------|----------------|----------------|----------------|
| (a) $3x - 6$ | (b) $4y - 8$ | (c) $16 - 8a$ | (d) $10c - 15$ |
| (e) $9s - 12$ | (f) $2b - 14$ | (g) $12x - 20$ | (h) $22m - 33$ |
| (i) $15x - 10$ | (j) $18 - 12y$ | (k) $25b - 20$ | (l) $18d - 30$ |

4. Factorise by finding the common factor:

- | | | | |
|-----------------|-----------------|-----------------|-----------------|
| (a) $2a + 4b$ | (b) $10x - 12y$ | (c) $18m + 24n$ | (d) $10c + 15d$ |
| (e) $6a - 9x$ | (f) $18s - 12t$ | (g) $12x + 15y$ | (h) $14a - 7b$ |
| (i) $25c + 10d$ | (j) $9b - 15y$ | (k) $18x + 24y$ | (l) $6a + 28b$ |

5. Factorise by finding the common factor

- | | | |
|-----------------|-------------------|-----------------|
| (a) $ax + ay$ | (b) $xy^2 + xa^2$ | (c) $pqr + pst$ |
| (d) $xay - bac$ | (e) $pq + p$ | (f) $y^2 + y$ |
| (g) $a^2 - ab$ | (h) $ab - bc$ | (i) $n^2 - 3n$ |
| (j) $xy + y^2$ | (k) $abc - abd$ | (l) $fgh - efg$ |

6. Factorise by finding the highest common factor:

(a) $2ax + 6a$ (b) $3y + 9y^2$ (c) $24a - 16ab$

(d) $pq^2 - pq$ (e) $12xy - 9xz$ (f) $6b^2 - 4b$

(g) $3a^2 + 27ah$ (h) $15abc + 20abd$ (i) $3s^3 - 9s^2$

(j) $14x - 12xyz$ (k) $10b^2c - 15bcd$ (l) $2\pi r^2 + 2\pi rh$

7. Factorise by finding the highest common factor:

(a) $ap + aq - ar$ (b) $2a + 2b + 2c$ (c) $6e - 2f + 4g$

(d) $p^2 + pq + xp$ (e) $3ab - 6bc - 9bd$ (f) $\frac{1}{2}ah + \frac{1}{2}bh + \frac{1}{2}ch$

(g) $5x^2 - 8xy + 5x$ (h) $4ac + 6ad - 10a^2$ (i) $15p^2 + 10pq + 20ps$

8. Factorise the following expressions, which contain a difference of squares:

(a) $a^2 - b^2$ (b) $x^2 - y^2$ (c) $p^2 - q^2$ (d) $s^2 - t^2$

(e) $a^2 - 3^2$ (f) $x^2 - 2^2$ (g) $p^2 - 9^2$ (h) $c^2 - 5^2$

(i) $b^2 - 1$ (j) $y^2 - 16$ (k) $m^2 - 25$ (l) $a^2 - 9$

(m) $36 - d^2$ (n) $4 - q^2$ (o) $49 - w^2$ (p) $x^2 - 64$

9. Factorise the following expressions, which contain a difference of squares:

(a) $a^2 - 4b^2$ (b) $x^2 - 25y^2$ (c) $p^2 - 64q^2$ (d) $16c^2 - d^2$

(e) $81 - 4g^2$ (f) $36w^2 - y^2$ (g) $4a^2 - 1$ (h) $g^2 - 81h^2$

(i) $49x^2 - y^2$ (j) $9c^2 - 16d^2$ (k) $4p^2 - 9q^2$ (l) $b^2 - 100c^2$

(m) $25 - 16a^2$ (n) $4d^2 - 121$ (o) $225 - 49k^2$ (p) $9x^2 - 0.25$

10. Factorise the following expressions which contain a common factor and a difference of two squares:

(a) $2a^2 - 2b^2$ (b) $5p^2 - 5$ (c) $45 - 5x^2$ (d) $4d^2 - 36$

(e) $2y^2 - 50$ (f) $4b^2 - 100$ (g) $3q^2 - 27$ (h) $8a^2 - 32b^2$

(i) $ab^2 - 64a$ (j) $xy^2 - 25x$ (k) $abc^2 - ab$ (l) $8p^2 - 50q^2$

(m) $2x^2 - 2 \cdot 88$ (n) $ak^2 - 121a$ (o) $10s^2 - 2 \cdot 5$ (p) $\frac{1}{2}y^2 - 450$

11. Factorise the following quadratic expressions:

(a) $x^2 + 3x + 2$

(b) $a^2 + 2a + 1$

(c) $y^2 + 5y + 4$

(d) $x^2 + 8x + 7$

(e) $x^2 + 6x + 9$

(f) $b^2 + 8b + 12$

(g) $a^2 + 9a + 14$

(h) $w^2 + 10w + 9$

(i) $d^2 + 7d + 10$

(j) $x^2 + 10x + 21$

(k) $p^2 + 9p + 20$

(l) $c^2 + 10c + 24$

(m) $s^2 + 12s + 36$

(n) $x^2 + 11x + 28$

(o) $y^2 + 10y + 25$

12. Factorise the following quadratic expressions:

(a) $a^2 - 8a + 15$

(b) $x^2 - 9x + 8$

(c) $c^2 - 9c + 18$

(d) $y^2 - 4y + 4$

(e) $b^2 - 6b + 5$

(f) $x^2 - 15x + 14$

(g) $c^2 - 10c + 16$

(h) $x^2 - 7x + 6$

(i) $y^2 - 12n + 32$

(j) $p^2 - 11p + 24$

(k) $a^2 - 13a + 36$

(l) $x^2 - 15x + 36$

(m) $b^2 - 4b + 3$

(n) $q^2 - 11q + 10$

(o) $a^2 - 7y + 12$

13. Factorise the following quadratic expressions:

(a) $b^2 + 3b - 10$

(b) $x^2 + 6x - 7$

(c) $y^2 - y - 6$

(d) $a^2 - a - 20$

(e) $q^2 + 2q - 8$

(f) $x^2 - 8x - 20$

(g) $d^2 + 4d - 21$

(h) $c^2 + 9c - 36$

(i) $p^2 - 5p - 24$

(j) $y^2 - 7y - 8$

(k) $a^2 + 5a - 6$

(l) $x^2 - 5x - 36$

(m) $b^2 - 4b - 5$

(n) $s^2 + 2s - 24$

(o) $d^2 + 6d - 16$

14. Factorise the following quadratic expressions:

(a) $3x^2 + 7x + 2$

(b) $2a^2 + 5a + 2$

(c) $3c^2 + 8c + 5$

(d) $2p^2 + 11p + 9$

(e) $2y^2 + 11y + 5$

(f) $3d^2 + 11d + 6$

(g) $5q^2 + 9q + 4$

(h) $4b^2 + 8b + 3$

(i) $6x^2 + 13x + 6$

(j) $3a^2 + 14a + 15$

(k) $10x^2 + 17x + 3$

(l) $9c^2 + 6c + 1$

(m) $6y^2 + 11y + 3$

(n) $3b^2 + 5b + 2$

(o) $8x^2 + 14x + 3$

15. Factorise the following quadratic expressions:

- | | | |
|-----------------------|-----------------------|-----------------------|
| (a) $2x^2 - 7x + 3$ | (b) $2a^2 - 5a + 3$ | (c) $5p^2 - 17p + 6$ |
| (d) $5b^2 - 7b + 2$ | (e) $6x^2 - 7x + 2$ | (f) $4y^2 - 11y + 6$ |
| (g) $7c^2 - 29c + 4$ | (h) $4m^2 - 9m + 2$ | (i) $16a^2 - 10a + 1$ |
| (j) $8y^2 - 22y + 5$ | (k) $3p^2 - 37p + 12$ | (l) $4x^2 - 25x + 6$ |
| (m) $15a^2 - 16a + 4$ | (n) $24c^2 - 22c + 3$ | (o) $6b^2 - 35b + 36$ |

16. Factorise the following quadratic expressions:

- | | | |
|-----------------------|------------------------|-----------------------|
| (a) $3x^2 - 2x - 1$ | (b) $2a^2 - a - 3$ | (c) $4p^2 - p - 3$ |
| (d) $2c^2 + 7c - 4$ | (e) $6y^2 - 11y - 2$ | (f) $3w^2 + 10w - 8$ |
| (g) $3m^2 + 2m - 5$ | (h) $4q^2 + 5q - 6$ | (i) $6b^2 + 7b - 20$ |
| (j) $4t^2 - 4t - 3$ | (k) $12z^2 + 16z - 3$ | (l) $4d^2 - 4d - 15$ |
| (m) $7s^2 - 27s - 4$ | (n) $15x^2 + 16x - 15$ | (o) $36v^2 + v - 2$ |
| (p) $3v^2 + 10v + 7$ | (q) $2l^2 - 11l + 5$ | (r) $12m^2 - 31m + 7$ |
| (s) $3n^2 - 19v + 28$ | (t) $4b^2 - 20b + 25$ | (u) $9c^2 + 18c + 8$ |
| (v) $3q^2 + 14q - 5$ | (w) $6a^2 + a - 12$ | (x) $8b^2 - 2b - 15$ |
| (y) $12m^2 - 8m - 15$ | (z) $2n^2 - n - 28$ | |

17. Fully factorise these expressions:

- | | | |
|------------------------|------------------------|-----------------------|
| (a) $3x^2 - 3$ | (b) $2p^2 + 12p + 10$ | (c) $9x^2 - 36$ |
| (d) $5x^2 + 25x + 30$ | (e) $ax^2 + 5ax + 6a$ | (f) $3y^2 - 12y - 15$ |
| (g) $15c^2 + 27c + 12$ | (h) $16b^2 + 28b + 6$ | (i) $9q^2 + 33q + 18$ |
| (j) $10s^2 - 35s + 15$ | (k) $8m^2 - 20m + 12$ | (l) $8a^2 - 36a + 36$ |
| (m) $4t^2 + 2t - 56$ | (n) $90d^2 - 60d - 80$ | (o) $400x^2 - 4$ |

2.3 COMPLETING THE SQUARE

1. Write the following in the form $(x + a)^2 + b$ and write down the minimum value of each one.
- (a) $x^2 + 4x$ (b) $x^2 + 10x$ (c) $x^2 + 7x$ (d) $x^2 + 9x$
(e) $x^2 - 6x$ (f) $x^2 - 8x$ (g) $x^2 - 5x$ (h) $x^2 - 11x$
2. Write the following in the form $(x + a)^2 + b$ and write down the minimum value of each one.
- (a) $x^2 + 2x + 7$ (b) $x^2 + 6x + 2$ (c) $x^2 + 8x + 9$
(d) $x^2 + 10x + 27$ (e) $x^2 + 4x - 8$ (f) $x^2 + 16x - 3$
(g) $x^2 - 6x + 11$ (h) $x^2 - 2x + 5$ (i) $x^2 - 8x + 8$
(j) $x^2 - 14x - 15$ (k) $x^2 - 12x + 21$ (l) $x^2 - 20x - 6$
3. Write the following in the form $(x + a)^2 + b$ and write down the maximum value of each one.
- (a) $4 + 2x - x^2$ (b) $7 + 4x - x^2$ (c) $3 - 6x - x^2$
(d) $10 - 10x - x^2$ (e) $14 + 3x - x^2$ (f) $5 - 7x - x^2$

2.4 REDUCING an ALGEBRAIC FRACTION to SIMPLEST FORM

1. Express these fractions in their simplest form:

(a) $\frac{3}{6}$

(b) $\frac{8}{12}$

(c) $\frac{30}{16}$

(d) $\frac{54}{72}$

(e) $\frac{10a}{5}$

(f) $\frac{9b}{6}$

(g) $\frac{18}{12x}$

(h) $\frac{25}{15y}$

(i) $\frac{4c}{16c^2}$

(j) $\frac{32a}{8a^3}$

(k) $\frac{13p^2}{52p^3}$

(l) $\frac{36ab}{6bc}$

(m) $\frac{4a}{2a^2}$

(n) $\frac{10x^2}{12xy}$

(o) $\frac{3v^2t}{9vt^2}$

(p) $\frac{10ab^3}{2a^2b}$

(q) $\frac{30p^2q}{25pq^2}$

(r) $\frac{81x^2y^2}{6y^2}$

(s) $\frac{42mn^2}{56mn}$

(t) $\frac{8def^2}{10e^2f}$

(u) $\frac{3ab^2c}{4a^2c}$

(v) $\frac{4k^2m}{28km^2}$

(w) $\frac{5efg^2}{10e^2fg^3}$

(x) $\frac{21xy^2}{36x^3}$

2. Simplify by first finding the common factor:

(a) $\frac{3a + 6b}{6}$

(b) $\frac{4x + 12y}{2}$

(c) $\frac{3a + a^2}{ab}$

(d) $\frac{xy + y^2}{2y}$

(e) $\frac{xy + x^2}{6x + xy}$

(f) $\frac{3ab + 6b^2}{9b^2}$

(g) $\frac{25b^2 + 15b^3}{10b}$

(h) $\frac{14p + 10q}{2s}$

(i) $\frac{3a}{2ab - ac}$

(j) $\frac{6x}{9x + 9y}$

(k) $\frac{2st}{6rs - 2st}$

(l) $\frac{5c}{10ac + 15bc}$

(m) $\frac{14p + 28p^2}{8 + 16p}$

(n) $\frac{8c + 4d}{6ac + 3ad}$

(o) $\frac{8n^2 - 2n}{12n - 3}$

(p) $\frac{15x^2 + 6xy}{10x + 4y}$

3. Simplify the following by first factorising the numerator and/or denominator:

(a) $\frac{b^2 - 4}{b + 2}$ (b) $\frac{x^2 - 81}{x - 9}$ (c) $\frac{a^2 - 25}{a + 5}$ (d) $\frac{y^2 - 36}{y + 6}$

(e) $\frac{c^2 - 49}{2c - 14}$ (f) $\frac{a^2 - 64}{2a + 16}$ (g) $\frac{p^2 - 1}{5p - 5}$ (h) $\frac{q^2 - 9}{3q + 9}$

(i) $\frac{a^2 - b^2}{3a + 3b}$ (j) $\frac{x^2 - y^2}{5x - 5y}$ (k) $\frac{2m^2 - 18}{2m + 6}$ (l) $\frac{3d^2 - 48}{12d - 48}$

(m) $\frac{x^2 + 3x + 2}{x + 1}$ (n) $\frac{p - 1}{p^2 - 2p + 1}$ (o) $\frac{ax - 5a}{x^2 - 25}$ (p) $\frac{a^2 - 1}{a^2 + 2a + 1}$

(q) $\frac{b^2 + 6p - 9}{b^2 - 9}$ (r) $\frac{c^2 + 2c - 15}{c^2 - 25}$ (s) $\frac{3x^2 + 5x - 2}{x^2 - 4}$

(t) $\frac{y^2 + 6y + 8}{y^2 + y - 12}$ (u) $\frac{p^2 - 4p - 5}{p^2 + 2p + 1}$ (v) $\frac{c^2 + 4c - 32}{c^2 + c - 56}$

(w) $\frac{2x^2 + 13x + 6}{x^2 + 9x + 18}$ (x) $\frac{6a^2 - 13a - 5}{3a^2 - 11a - 4}$ (y) $\frac{10b^2 - 33b - 7}{10b^2 - 37b + 7}$

2.5 APPLYING the FOUR OPERATIONS to ALGEBRAIC FRACTIONS

1. Express each sum as a fraction in its simplest form:

(a) $\frac{1}{5} + \frac{3}{5}$	(b) $\frac{2}{5} + \frac{1}{10}$	(c) $\frac{3}{4} + \frac{1}{8}$	(d) $\frac{1}{6} + \frac{2}{3}$
(e) $\frac{1}{9} + \frac{2}{3}$	(f) $\frac{1}{3} + \frac{1}{4}$	(g) $\frac{3}{5} + \frac{1}{4}$	(h) $\frac{1}{4} + \frac{1}{6}$
(i) $\frac{1}{3} + \frac{5}{8}$	(j) $\frac{1}{2} + \frac{2}{5}$	(k) $\frac{3}{4} + \frac{1}{6}$	(l) $\frac{1}{2} + \frac{3}{7}$
(m) $\frac{2}{7} + \frac{1}{8}$	(n) $\frac{1}{5} + \frac{3}{8}$	(o) $\frac{2}{9} + \frac{3}{7}$	(p) $\frac{1}{3} + \frac{4}{7}$

2. Express each difference as a fraction in its simplest form:

(a) $\frac{3}{4} - \frac{1}{4}$	(b) $\frac{1}{2} - \frac{1}{6}$	(c) $\frac{5}{6} - \frac{2}{3}$	(d) $\frac{11}{12} - \frac{5}{6}$
(e) $\frac{11}{12} - \frac{2}{3}$	(f) $\frac{1}{2} - \frac{1}{16}$	(g) $\frac{2}{3} - \frac{1}{4}$	(h) $\frac{1}{2} - \frac{2}{5}$
(i) $\frac{4}{5} - \frac{1}{2}$	(j) $\frac{7}{8} - \frac{3}{16}$	(k) $\frac{11}{12} - \frac{1}{3}$	(l) $\frac{7}{12} - \frac{1}{3}$
(m) $\frac{5}{8} - \frac{2}{5}$	(n) $\frac{5}{6} - \frac{3}{5}$	(o) $\frac{7}{9} - \frac{3}{7}$	(p) $\frac{5}{8} - \frac{7}{16}$

3. Express each product as a fraction in its simplest form:

(a) $\frac{1}{4} \times \frac{4}{7}$	(b) $\frac{1}{3} \times \frac{3}{10}$	(c) $\frac{1}{2} \times \frac{4}{7}$	(d) $\frac{2}{3} \times \frac{1}{8}$
(e) $\frac{4}{5} \times \frac{1}{16}$	(f) $\frac{6}{7} \times \frac{2}{3}$	(g) $\frac{3}{5} \times \frac{10}{21}$	(h) $\frac{3}{8} \times \frac{4}{21}$
(i) $\frac{21}{32} \times \frac{4}{7}$	(j) $\frac{1}{9} \times \frac{12}{13}$	(k) $\frac{5}{16} \times \frac{6}{25}$	(l) $\frac{5}{7} \times \frac{14}{15}$
(m) $\frac{7}{9} \times \frac{12}{35}$	(n) $\frac{12}{13} \times \frac{39}{48}$	(o) $\frac{2}{3} \times \frac{5}{9}$	(p) $\frac{5}{8} \times \frac{11}{15}$

4. Express as a single fraction:

(a) $\frac{1}{4} \div \frac{1}{3}$

(b) $\frac{2}{5} \div \frac{2}{7}$

(c) $\frac{4}{5} \div \frac{3}{4}$

(d) $\frac{3}{7} \div \frac{2}{5}$

(e) $\frac{5}{12} \div \frac{5}{3}$

(f) $\frac{5}{9} \div \frac{1}{3}$

(g) $\frac{2}{5} \div \frac{9}{10}$

(h) $\frac{3}{7} \div \frac{11}{14}$

(i) $\frac{4}{9} \div \frac{2}{3}$

(j) $\frac{2}{5} \div \frac{4}{5}$

(k) $\frac{24}{35} \div \frac{20}{21}$

(l) $\frac{6}{25} \div \frac{9}{20}$

(m) $\frac{8}{21} \div \frac{9}{14}$

(n) $\frac{10}{21} \div \frac{8}{9}$

(o) $\frac{20}{33} \div \frac{15}{44}$

(p) $\frac{7}{30} \div \frac{5}{20}$

5. Express each sum as a fraction in its simplest form:

(a) $\frac{a}{5} + \frac{a}{5}$

(b) $\frac{2b}{5} + \frac{b}{10}$

(c) $\frac{3x}{4} + \frac{x}{8}$

(d) $\frac{p}{6} + \frac{2p}{3}$

(e) $\frac{y}{9} + \frac{2y}{3}$

(f) $\frac{3}{m} + \frac{2}{m}$

(g) $\frac{5}{x} + \frac{1}{x}$

(h) $\frac{2}{a} + \frac{5}{2a}$

(i) $\frac{4}{3y} + \frac{3}{y}$

(j) $\frac{8}{p} + \frac{3}{5p}$

(k) $\frac{3}{a} + \frac{2}{b}$

(l) $\frac{5}{x} + \frac{3}{y}$

(m) $\frac{2}{m} + \frac{7}{n}$

(n) $\frac{4}{p} + \frac{3}{q}$

(o) $\frac{9}{c} + \frac{7}{d}$

(p) $\frac{3}{2x} + \frac{2}{3y}$

(q) $\frac{4}{3a} + \frac{5}{2b}$

(r) $\frac{2}{3a} + \frac{9}{3b}$

(s) $\frac{5}{4m} + \frac{3}{2n}$

(t) $\frac{7}{3p} + \frac{2}{6q}$

(u) $\frac{1}{a} + \frac{2}{a^2}$

(v) $\frac{5}{x^2} + \frac{3}{x}$

(w) $\frac{3}{3b} + \frac{4}{b^2}$

(x) $\frac{8}{2m} + \frac{5}{3m^2}$

6. Express each difference as a fraction in its simplest form:

(a) $\frac{3a}{5} - \frac{a}{5}$

(b) $\frac{2b}{5} - \frac{b}{10}$

(c) $\frac{3x}{4} - \frac{x}{8}$

(d) $\frac{5p}{6} - \frac{2p}{3}$

(e) $\frac{8y}{9} + \frac{2y}{3}$

(f) $\frac{5}{m} - \frac{2}{m}$

(g) $\frac{7}{x} - \frac{3}{x}$

(h) $\frac{5}{a} - \frac{1}{2a}$

(i) $\frac{8}{3y} - \frac{2}{y}$

(j) $\frac{8}{p} - \frac{3}{5p}$

(k) $\frac{3}{a} - \frac{2}{b}$

(l) $\frac{5}{x} - \frac{3}{y}$

6. (continued)

(m) $\frac{7}{m} - \frac{2}{n}$	(n) $\frac{4}{p} - \frac{3}{q}$	(o) $\frac{9}{c} - \frac{7}{d}$	(p) $\frac{3}{2x} - \frac{2}{3y}$
(q) $\frac{5}{3a} - \frac{3}{2b}$	(r) $\frac{5}{3a} - \frac{2}{3b}$	(s) $\frac{5}{4m} - \frac{3}{2n}$	(t) $\frac{7}{3p} - \frac{2}{6q}$
(u) $\frac{1}{a} - \frac{2}{a^2}$	(v) $\frac{7}{x^2} - \frac{3}{x}$	(w) $\frac{4}{3b} - \frac{3}{b^2}$	(x) $\frac{7}{2p^2} - \frac{4}{3p}$

7. Express each product as a fraction in its simplest form

(a) $\frac{x}{3} \times \frac{x}{6}$	(b) $\frac{y}{2} \times \frac{y}{4}$	(c) $\frac{a}{2} \times \frac{b}{7}$	(d) $\frac{p}{3} \times \frac{q}{8}$
(e) $\frac{c^2}{5} \times \frac{c}{6}$	(f) $\frac{6}{a} \times \frac{2}{a}$	(g) $\frac{3}{x} \times \frac{10}{y}$	(h) $\frac{3}{p} \times \frac{4}{p}$
(i) $\frac{2}{3m} \times \frac{4}{5m}$	(j) $\frac{1}{b} \times \frac{11}{3c}$	(k) $\frac{5m}{6} \times \frac{3}{2m}$	(l) $\frac{5}{7x} \times \frac{4x}{3}$
(m) $\frac{2y}{9} \times \frac{12}{5y^2}$	(n) $\frac{2}{3a} \times \frac{3}{7a^2}$	(o) $\frac{5}{3p} \times \frac{2}{p^3}$	(p) $\frac{3t^2}{5s} \times \frac{2s^2}{6t^3}$
(q) $\frac{5pq}{2} \times \frac{3}{4pq^2}$	(r) $\frac{7ab^2}{6c} \times \frac{2c^3}{3a^2}$	(s) $\frac{4}{5mn} \times \frac{2m^4}{n^2}$	
(t) $\frac{4yz}{9x} \times \frac{3xz}{2y^3}$	(u) $\frac{5ab^3}{3c} \times \frac{3a}{2bc^2}$	(v) $\frac{2cd}{7a} \times \frac{3a^2}{4cd^2}$	
(w) $\frac{10xy^2}{3} \times \frac{12xy}{5y^2}$	(x) $\frac{3}{8s^3} \times \frac{4st}{t^3}$	(y) $\frac{4pq^2}{3a} \times \frac{6a^2}{5p^3}$	

8. Express as a single fraction:

(a) $\frac{a}{4} \div \frac{a}{2}$	(b) $\frac{x}{2} \div \frac{y}{2}$	(c) $\frac{ab}{5} \div \frac{a}{2}$
(d) $\frac{p^2}{10} \div \frac{p}{5}$	(e) $\frac{2c}{3} \div \frac{c^2}{6}$	(f) $\frac{3}{t} \div \frac{6}{t}$

8. (continued)

(g) $\frac{2}{k} \div \frac{4}{m}$

(h) $\frac{3}{y} \div \frac{9}{y^2}$

(i) $\frac{4}{bc} \div \frac{2}{c}$

(j) $\frac{3}{2x} \div \frac{12}{x^2}$

(k) $\frac{24xy}{35z} \div \frac{20xy}{21z}$

(l) $\frac{6q^2}{25p} \div \frac{9q}{20p^2}$

(m) $\frac{8ab}{21c} \div \frac{9b}{14ac}$

(n) $\frac{10m}{21n^2} \div \frac{8mn}{9}$

(o) $\frac{20ax}{33y} \div \frac{15x}{44ay^2}$

9. Simplify the following:

(a) $\frac{x+2}{3} + \frac{x+3}{6}$

(b) $\frac{a+6}{4} + \frac{a-2}{3}$

(c) $\frac{d-3}{2} - \frac{d+2}{6}$

(d) $\frac{2a-1}{4} - \frac{a+2}{5}$

(e) $\frac{a+3b}{2} + \frac{a-2b}{4}$

(f) $\frac{2u+v}{3} - \frac{u-v}{4}$

(g) $\frac{2}{x+3} + \frac{3}{x+2}$

(h) $\frac{4}{x+5} + \frac{5}{x+1}$

(i) $\frac{7}{x-3} + \frac{4}{x+2}$

(j) $\frac{2}{x+4} - \frac{3}{x-3}$

(k) $\frac{1}{x-3} - \frac{5}{x-2}$

(l) $\frac{2}{x-5} - \frac{3}{x-4}$

ALGEBRAIC FRACTIONS**EXAM QUESTIONS**

1. Write as a single fraction in its simplest form $\frac{5}{x+2} + \frac{4}{x} : x \neq -2, x \neq 0.$

2. Simplify this fraction $\frac{2x^2 - 5x + 3}{4x^2 - 9}$

3. Simplify fully the fraction $\frac{6e^2 - 3e}{4e^2 - 1}$

4. Simplify $\frac{3}{x+2} - \frac{5}{x-1}$

5. Write as a single fraction in its simplest form: $\frac{3a}{5x} \div \frac{a}{x^2}$

6. Express as a single fraction in its simplest form: $\frac{3}{x} - \frac{2}{x-5}.$

3.1 DETERMINING the GRADIENT of a STRAIGHT LINE given TWO POINTS

1. (a) Calculate the gradient of each line in the diagram opposite.

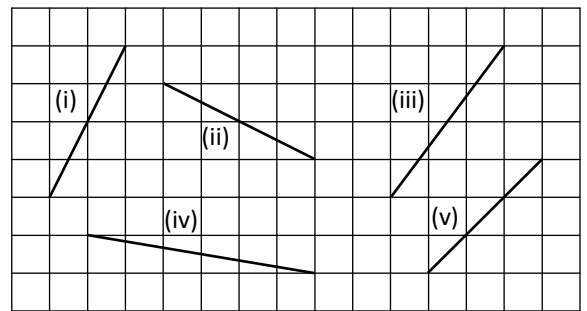

- (b) Copy and complete each statement below:

The gradient of any horizontal line is _____.

The gradient of any vertical line is _____.

A line sloping upwards from left to right has a _____ gradient.

A line sloping upwards from right to left has a _____ gradient.

2. Find the **gradients** of the lines shown in each of the diagrams below:

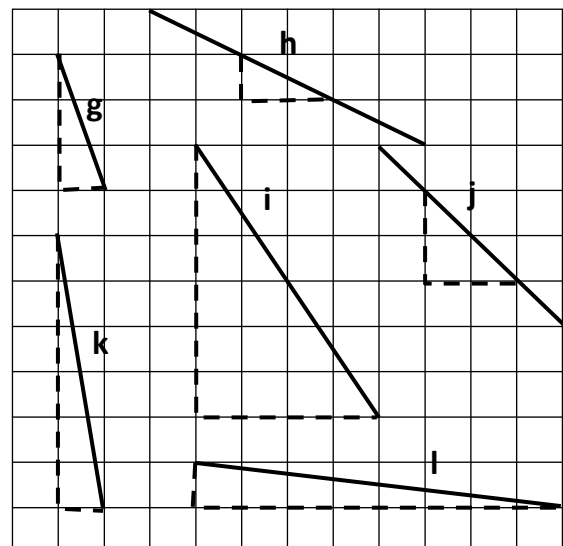
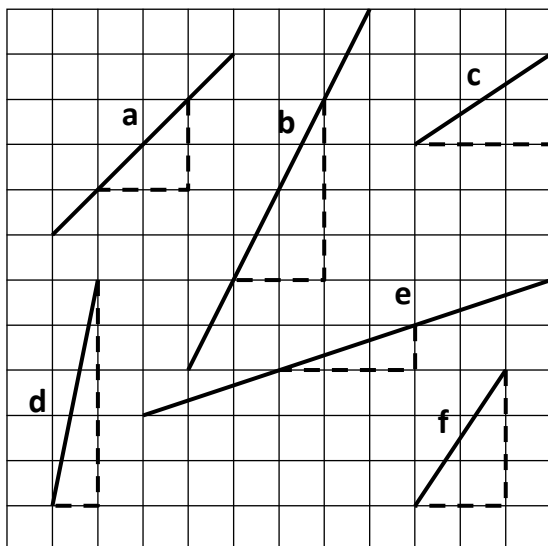

3. Find the **gradients** of the lines below:

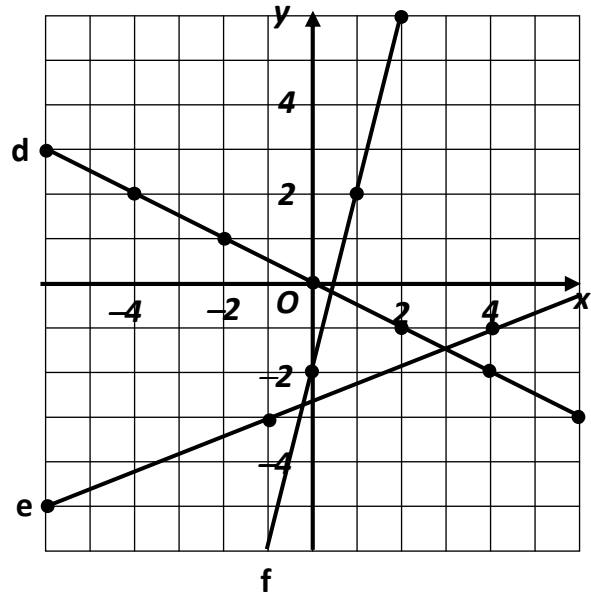
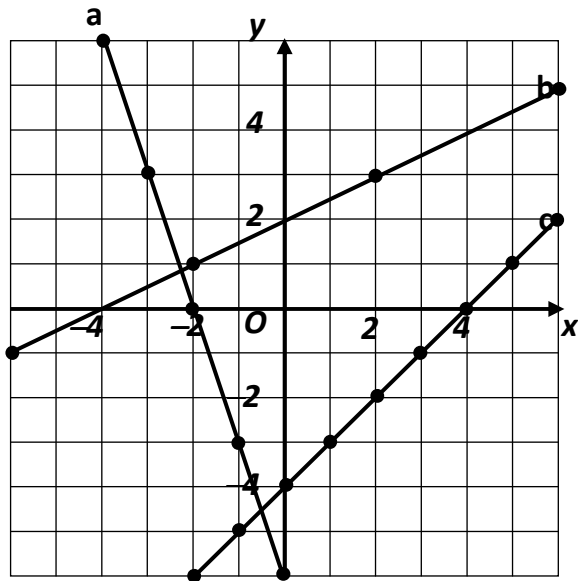

4. Calculate the gradient of the line joining each pair of points below:

- (a) (2, 1) and (6, 3) (b) (1, 5) and (3, 1) (c) (2, 0) and (4, 6)
 (d) (4, 3) and (8, 11) (e) (1, 9) and (3, 1) (f) (7, 3) and (5, 2)
 (g) (-2, -3) and (2, 3) (h) (-1, 2) and (5, -1) (i) (-4, 2) and (4, -4)
 (j) (-6, -2) and (-5, 3) (k) (4, -3) and (6, 5) (l) (-2, 3) and (0, -2)

5. Calculate the gradient of the line joining each pair of points below:

- (a) A(-2, 6) and B(8, 8) (b) C(3, -3) and D(4, -1)
 (c) E(5, -9) and F(8, -15) (d) G(0, 6) and H(5, 11)
 (e) I(-1, -3) and J(7, -9) (f) K(-4, 0) and L(-1, 5)
 (g) M(2, 2) and N(-3, 4) (h) P(5, -1) and Q(-2, 10)
 (i) R(-3, -5) and S(8, -4) (j) T(4, -6) and U(7, -2)
 (k) V(5, -6) and W(-2, 6) (l) X(-1, 7) and Y(-2, 6)
 (m) J(6, 8) and K(-3, -5) (n) S(3, -5) and T(-2, 8)
 (o) D(6, -3) and E(0, 4) (p) F(6, 9) and G(-5, -5)

6. Prove that the following sets of points are collinear:
- (a) $A(-6, -1)$, $B(2, 3)$ and $C(4, 4)$
 - (b) $P(1, -1)$, $Q(-3, 5)$ and $R(7, -10)$
 - (c) $E(5, -3)$, $F(11, -2)$ and $G(-7, -5)$
 - (d) $K(5, -4)$, $L(-1, 4)$ and $M(9\frac{1}{2}, -10)$
7. Given that each set of points are collinear, find the value of k in each case:
- (a) $P(-4, -2)$, $Q(-1, -1)$ and $R(8, k)$
 - (b) $A(1, 3)$, $B(3, k)$ and $C(4, -6)$
 - (c) $E(-4, -1)$, $F(k, -1)$ and $G(8, 7)$
 - (d) $S(k, 2)$, $T(9, 1)$ and $U(-3, 4)$
8. The points E and F have coordinates $(2, -5)$ and $(-4, a)$ respectively. Given that the gradient of the line EF is $\frac{2}{3}$, find the value of a .
9. If the points $(3, 2)$, $(-1, 0)$ and $(4, k)$ are collinear, find k .
10. Given that the points $(3, -2)$, $(4, 5)$ and $(-1, a)$ are collinear, find the value of a .
11. The line which passes through $(1, 4)$ and $(2, 5)$ is parallel to the line through $(3, 7)$ and $(k, 5)$. Find the value of k .
12. The line which passes through $(-2, 3)$ and $(-5, -9)$ is parallel to the line through $(4, k)$ and $(-1, -1)$. Find the value of k .

3.2 WORKING with the LENGTH of an ARC of a CIRCLE

1. Calculate the length of the arc in each diagram below, giving your answer correct to 1 d.p.

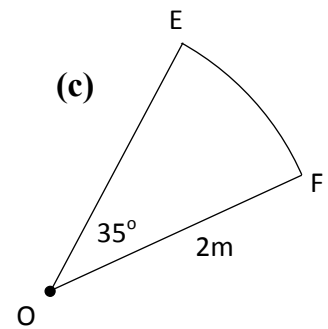
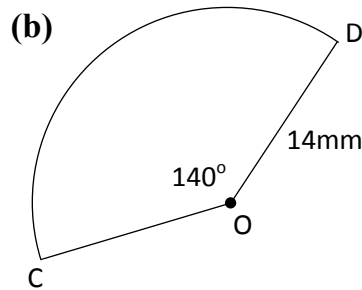
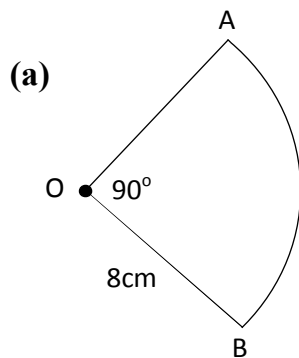

2. Calculate the perimeter of each sector in Question 1. Giving your answers correct to 1 d.p.

3. Find the length of the minor arc AB in each of the following circles, giving your answers correct to 1 d.p.

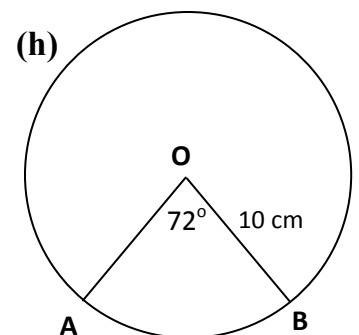
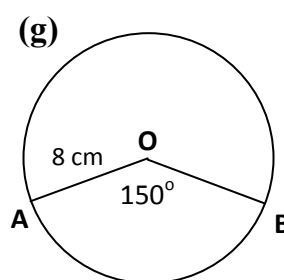
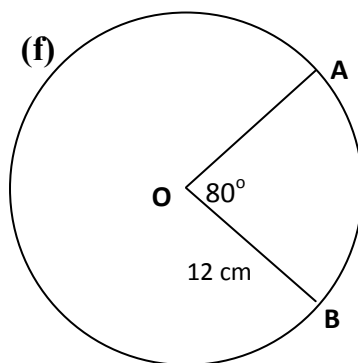
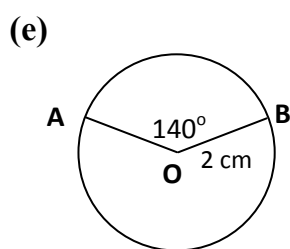
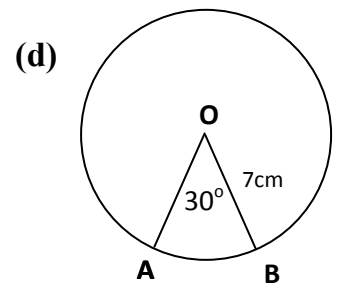
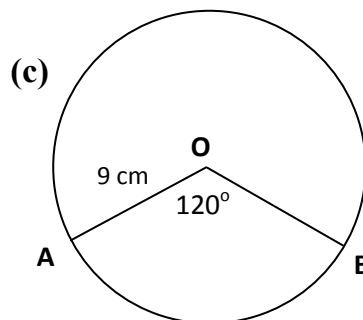
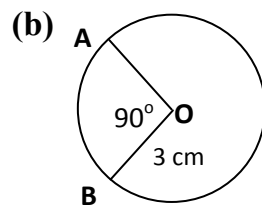
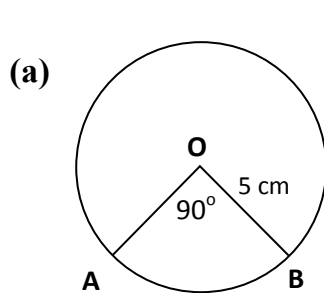

4. Calculate the length of the major arc in the circles shown in Question 3, giving your answers correct to 1 d.p.

3.2 WORKING with the AREA of a SECTOR of a CIRCLE

1. Calculate the area of the sector in each diagram below, giving your answer correct to 3 significant figures.

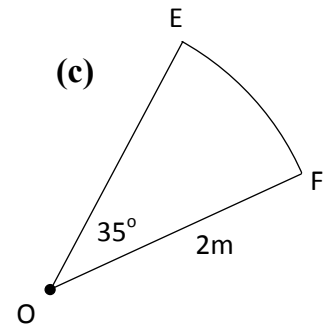
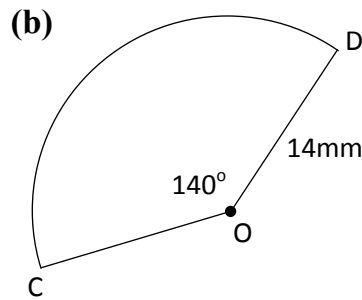
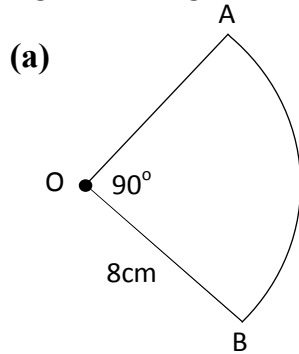

2. Calculate the area of minor sector OAB in the circles shown below, giving your answers correct to 3 significant figures.

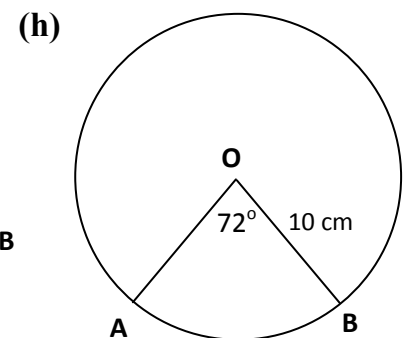
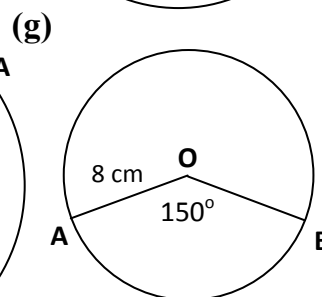
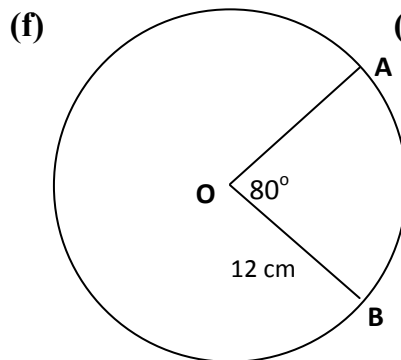
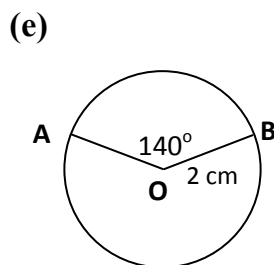
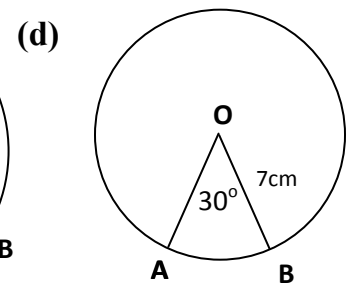
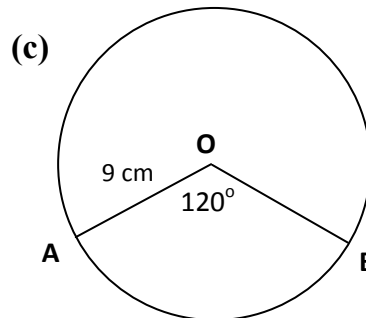
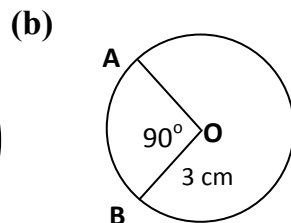
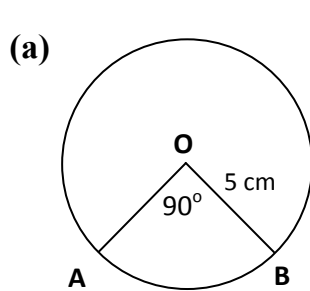

3. Calculate the area of the major sector for the circles in Question 2, giving your answers correct to 3 significant figures.

4. The length of minor arc CD is 7.33 cm.

Calculate the area of the circle.

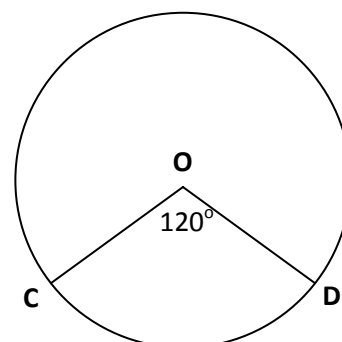

3.2 WORKING with the ARCS and SECTORS of a CIRCLE EXAM QUESTIONS

Give your answers correct to 3 significant figures unless otherwise stated.

1. Calculate the area of the sector shown in the diagram, given that it has radius 6.8cm .

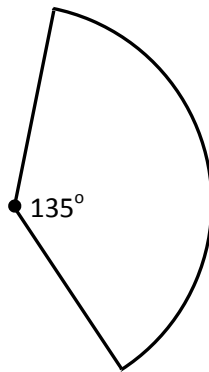

2. A table is in the shape of a sector of a circle with radius 1.6m .

The angle at the centre is 130° as shown in the diagram.

Calculate the perimeter of the table.

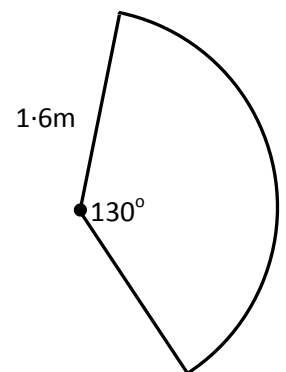

3. The door into a restaurant kitchen swings backwards and forwards through 110° .



The width of the door is 90cm .

Calculate the area swept out by the door as it swings back and forth.

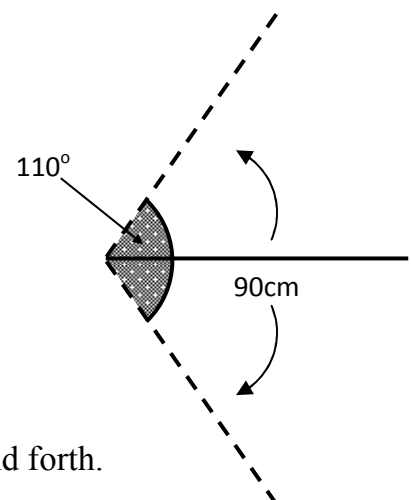

4. The YUMMY ICE CREAM Co uses this logo.



It is made up from an isosceles triangle and a sector of a circle as shown in the diagram.

- The equal sides of the triangle are 6cm
- The radius of the sector is 3.3cm.

Calculate the perimeter of the logo.

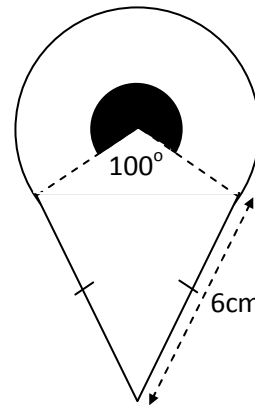

5. A sensor on a security system covers a horizontal area in the shape of a sector of a circle of radius 3.5m.

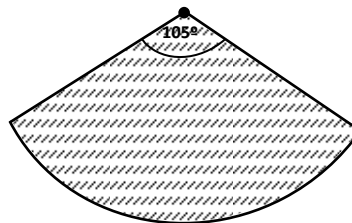

The sensor detects movement in an area with an angle of 105° .

Calculate the area covered by the sensor.

6. A biscuit is in the shape of a sector of a circle with triangular part removed as shown in the diagram.

The radius of the circle, PQ, is 7 cm and $PS = 1.5$ cm.

Angle $QPR = 80^\circ$.

Calculate the area of the biscuit.

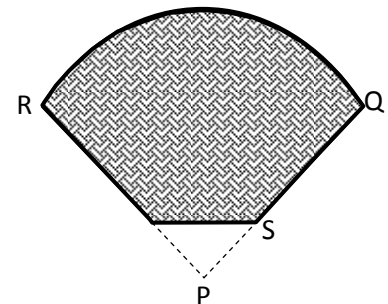

7. Two congruent circles overlap to form the symmetrical shape shown below. Each circle has a diameter of 12 cm and have centres at B and D.

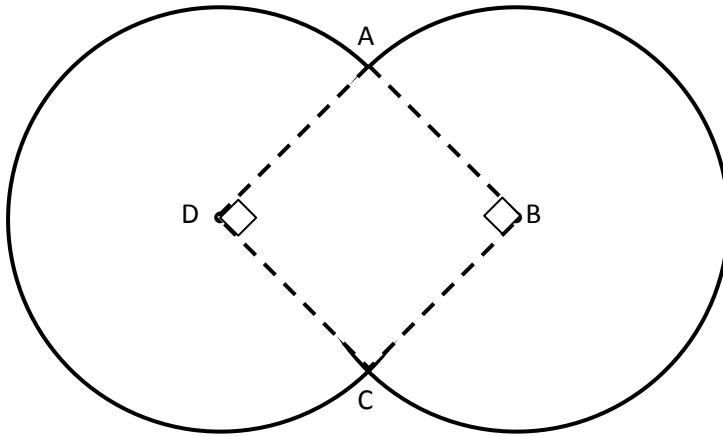

Calculate the area of the shape.

8. A sector of a circle with radius 6cm is shown opposite.

Angle $AOB = x^\circ$

If the exact **area** of the sector is 4π square centimetres, calculate the size of the angle marked x .

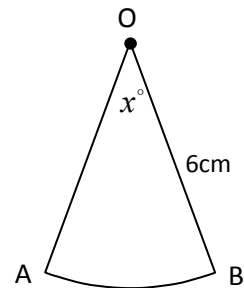

9. A hand fan is made of wooden slats with material on the outer edge.

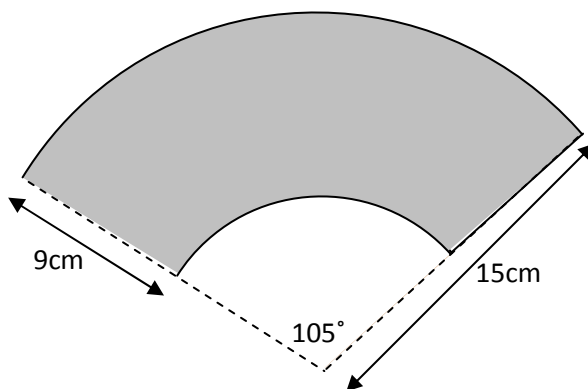

- (a) Calculate the area of material needed for the hand fan.
- (b) Calculate the perimeter of the shaded area in the diagram above.

10.

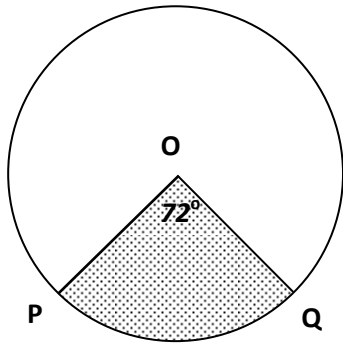

The area of the shaded sector is 5.024 cm^2 .
Calculate the area of the circle.

11. The area sector OPQ is 78.5 cm^2 .
Calculate the size of angle x° of the circle.

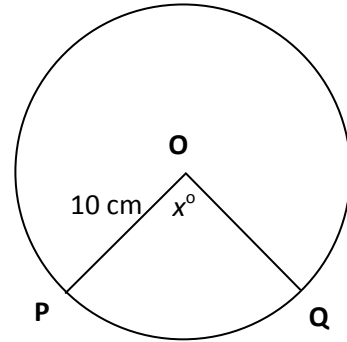

12. A school baseball field is in the shape of a sector of a circle as shown.

Given that O is the centre of the circle, calculate:

- (a) the perimeter of the playing field;
- (b) the area of the playing field.

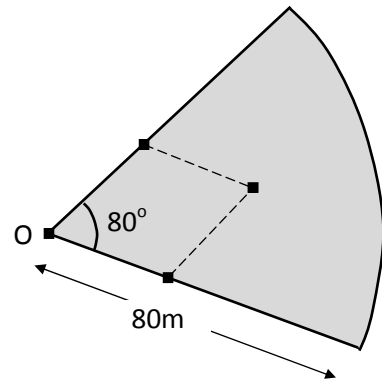

13. In the diagram opposite, O is the centre of two concentric circles with radii 16cm and 20cm as shown.

Angle $AOB = 120^\circ$.

- Calculate:
- (a) The **perimeter** of the shaded shape.
 - (b) The shaded area.

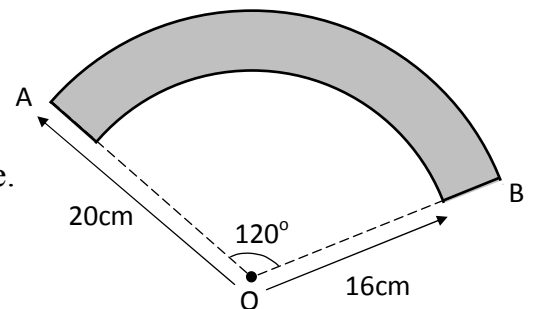

14. A Japanese paper fan is fully opened when angle $PQR = 150^\circ$ as shown.

- (a) Using the dimensions shown in *diagram 1*, calculate the approximate area of paper material in the fan.

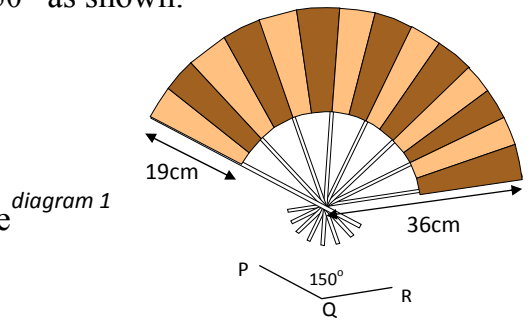
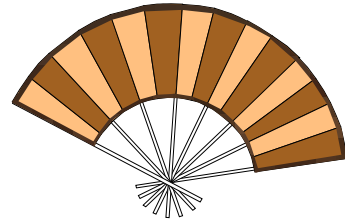

diagram 2

- (b) Decorative silk bands are placed along the edges as shown in *diagram 2*, calculate the approximate total length of this silk edging strip.



15. A grandfather clock has a pendulum which travels along an arc of a circle, centre O.

- The arm length of the pendulum is 60cm.
- The pendulum swings from position OA to OB.
- The length of the arc AB is 21cm.

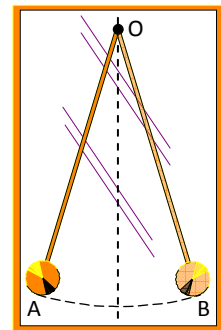

Calculate the size of angle AOB to the nearest degree.

16. The shape opposite is the sector of a circle, centre P, radius 20m.

The area of the sector is 251.2 square metres.

Find the length of the arc QR.

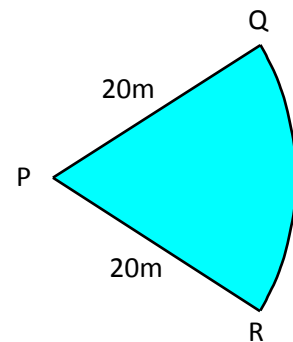

17. A metal strip has been moulded into an arc of a circle of radius 155 centimetres which subtends an angle of 82° at the centre of the circle as shown in the diagram below.

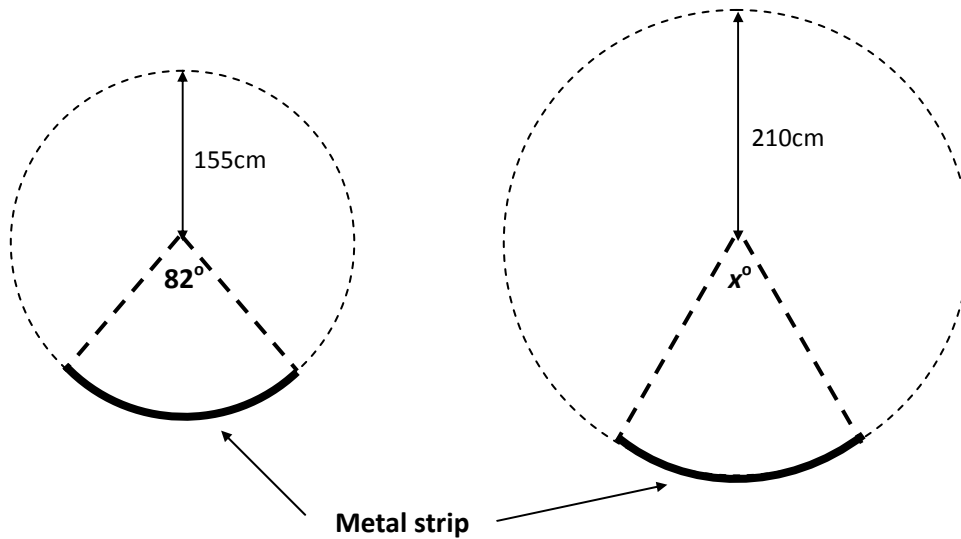

The **same strip** of metal has now been remoulded to form an arc of a circle of radius 210 centimetres as shown.

Calculate the size of x , the angle now subtended by the metal strip.

18. Draw a diagram to help you answer these questions.
- (a) A circle, centre O, has an arc PQ of length 40cm.
If the diameter of the circle is 80cm, calculate the size of angle POQ correct to 1 d.p.
- (b) A circle, centre O, has a sector EOF with an area of 50cm^2 .
If the radius of the circle is 8cm, calculate the size of angle EOF correct to 1 d.p.
- (c) An arc AB on a circle, centre O, has a length of 16mm.
If angle AOB = 75° , calculate the radius of this circle.
- (d) A sector of a circle has an area of 12cm^2 . If the angle at the centre is 60° , calculate the diameter of the circle correct to 2-decimal places.

WORKING with VOLUME of a CYLINDER

This topic is not mentioned in National 5 arrangements but worth covering at this stage

1. Circular – based prism (cylinder)

Find the volume of a circular-based prism for the values of r and h given.

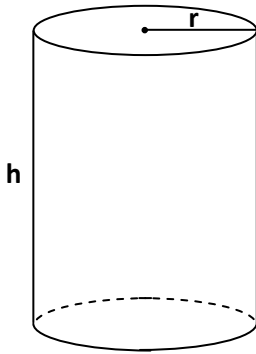

- | | | |
|-----|--------------|--------------|
| (a) | $r = 6$ cm | $h = 15$ cm |
| (b) | $r = 8$ cm | $h = 24$ cm |
| (c) | $r = 4$ cm | $h = 12$ cm |
| (d) | $r = 10$ cm | $h = 8$ cm |
| (e) | $r = 20$ cm | $h = 60$ cm |
| (f) | $r = 7$ cm | $h = 20$ cm |
| (g) | $r = 15$ cm | $h = 40$ cm |
| (h) | $r = 11$ cm | $h = 35$ cm |
| (i) | $r = 44$ cm | $h = 125$ cm |
| (j) | $r = 8.8$ cm | $h = 30$ cm |

2. A milk dispenser is cylindrical in shape with diameter 30cm.

- (a) If 14 litres of milk are poured into it, calculate the depth of the milk in the cylinder.

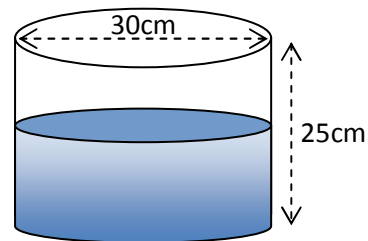

- (b) The height of the cylinder is 25cm.

How many **more** litres of milk are needed to completely fill it?

3.

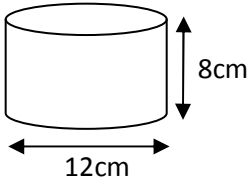

Calculate the volume of a cylinder with diameter 12cm and height 8cm.

4. This paint tin has diameter 20 cm and height 30 cm as shown in the diagram.

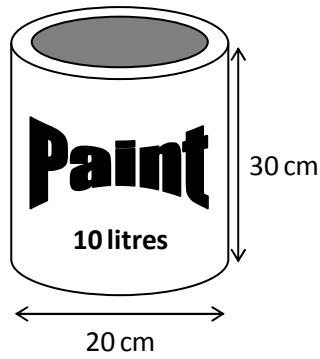

It is claimed that it can hold 10 litres of paint. Is this claim correct?

You must show all working and give a reason for your answer.

3.3 WORKING with the VOLUME of a SOLID SPHERE, CONE, PYRAMID

1. Calculate the volume of each sphere described below, rounding your answer to 1 decimal place.

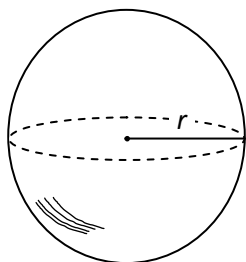

- (a) $r = 6\text{cm}$
(b) $r = 2\text{m}$
(c) $r = 9\text{mm}$
(d) $r = 3\text{cm}$

2. Find the volume of a sphere for the following values of r and d .
(give your answers correct to 3 significant figures)

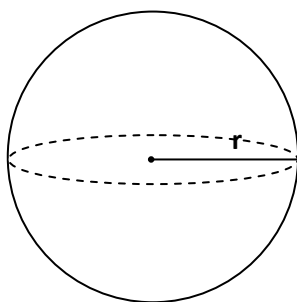

- | | |
|------------------------|-----------------------|
| (a) $r = 10\text{cm}$ | (f) $d = 18\text{cm}$ |
| (b) $r = 25\text{cm}$ | (g) $r = 80\text{mm}$ |
| (c) $d = 2\text{m}$ | (h) $d = 55\text{cm}$ |
| (d) $r = 200\text{mm}$ | (i) $r = 3.5\text{m}$ |
| (e) $d = 11\text{cm}$ | (j) $d = 48\text{cm}$ |

3. A sphere has a diameter of 8cm.

Calculate its volume giving your answer correct to 3 significant figures.

4. Find the volume of a cone for the following values of r and h .

(give your answers correct to 3 significant figures)

- | | |
|-----------------------|-------------------|
| (a) $r = 5\text{cm}$ | $h = 14\text{cm}$ |
| (b) $r = 7\text{cm}$ | $h = 25\text{cm}$ |
| (c) $r = 3\text{cm}$ | $h = 22\text{cm}$ |
| (d) $r = 12\text{cm}$ | $h = 7\text{cm}$ |

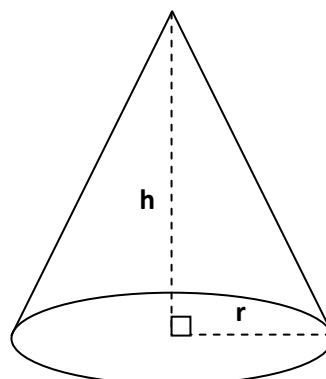

5. Find the volume of a cone for the following values of d and h .

(give your answers correct to 3 significant figures)

- (a) $d = 15\text{cm}$ $h = 40\text{cm}$
(b) $d = 11\text{cm}$ $h = 37\text{cm}$
(c) $d = 22\text{cm}$ $h = 125\text{cm}$
(d) $d = 8.8\text{cm}$ $h = 30\text{cm}$

6. Calculate the volume of each cone described below, rounding your answers to 1 decimal place.

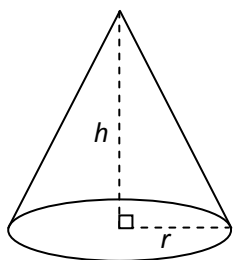

- (a) $r = 3\text{cm}$ and $h = 6\text{cm}$
(b) $r = 8\text{mm}$ and $h = 12\text{mm}$
(c) $r = 3\text{cm}$ and $h = 5\text{cm}$
(d) $r = 2\text{m}$ and $h = 6\text{m}$

7. A cone has a base diameter of 8cm and a height of 5cm. Calculate the volume of this cone.

8. A cone has a base diameter of 10cm and a **slant height** of 13cm.

Calculate the volume of the cone.

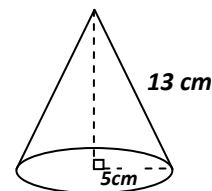

9. A cone has a base radius of 9cm and a **slant height** of 15cm.

Calculate the volume of the cone.

10. A pyramid has a square base of side 4cm and a vertical height of 7cm.

Calculate the volume of the pyramid correct to 2 significant figures.

11. A pyramid has a rectangular base measuring 16mm by 12mm and a vertical height of 10mm.

Calculate the volume of the pyramid.

WORKING with the VOLUME of a SOLID SPHERE, CONE, PYRAMID & CYLINDER

EXAM QUESTIONS

1. The Stockholm Globe Arena is the largest hemispherical building in the world.

The radius of the building is 110 m.

Calculate the volume of the building in cubic metres, giving your answer in scientific notation correct to 3 significant figures.



2. A metal bottle stopper is made up from a cone topped with a sphere.

The sphere has diameter 1.5cm.

The cone has radius 0.9cm.

The overall length of the stopper is 6.5cm.

Calculate the volume of metal required to make the stopper. Give your answer correct to 3 significant figures.

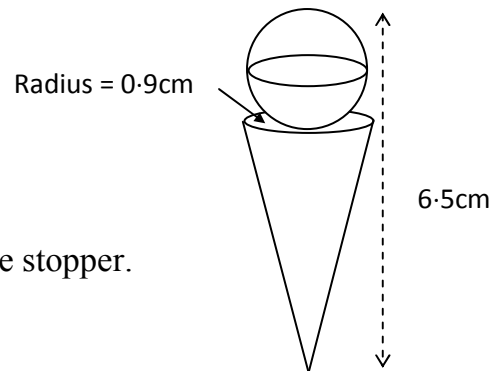

3. The volume of this sphere is 524cm^3 .

Calculate the diameter, d cm.

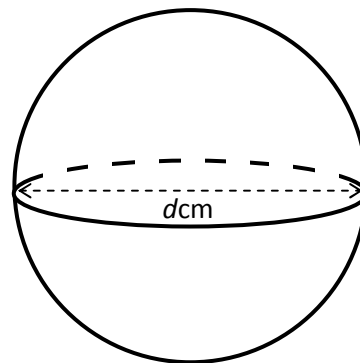

4. **Non Calculator!**

Calculate the volume of this sphere which has radius 3m.

[Take $\pi = 3.14$]

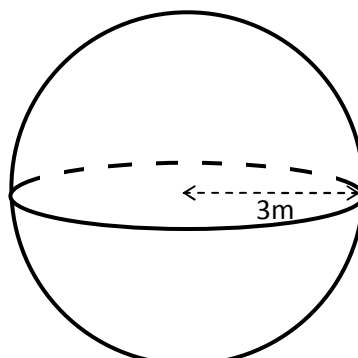

5. Sherbet in a sweet shop is stored in a cylindrical container like the one shown in *diagram 1*.

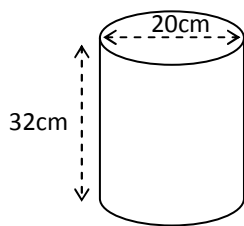

Diagram 1

The volume of the cylinder, correct to the nearest 1000cm^3 , is $10\,000\text{cm}^3$.

The sherbet is sold in conical containers with diameter 5 cm as shown in *diagram 2*.

250 of these cones can be filled from the contents of the cylinder.

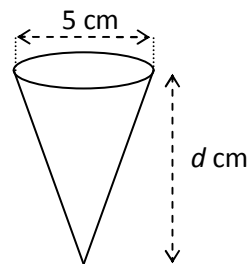

Diagram 2

Calculate the depth, d cm, of a sherbet cone.

6. **Non Calculator!**

The diagram shows a cone with radius 10 centimetres and height 30 centimetres.

Taking $\pi = 3.14$, calculate the volume of the cone.

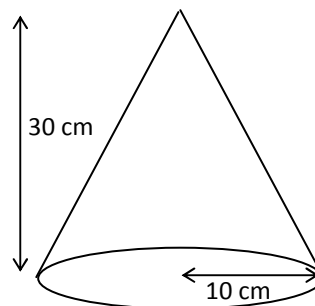

7. A children's wobbly toy is made from a cone, 21 cm high, on top of a hemispherical base of diameter 20 cm.

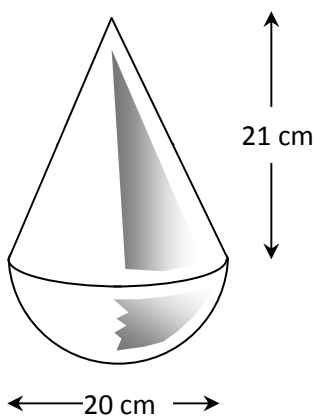

The toy has to be filled with liquid foam.

Calculate the volume of foam which will be required.

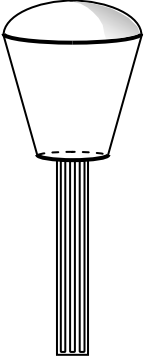
8.  The lamp cover in a street lamp is in the shape of a cone with the bottom cut off.
- The height of the cone is 50cm and its radius is 25cm. The height of the lamp is 30cm and the base of the lamp has a radius of 18cm
- Calculate the volume of the lamp cover. [Answer to 3 significant figures.]

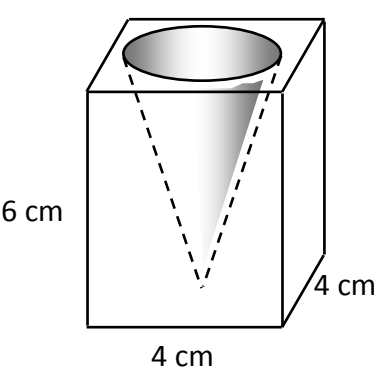
9.  A glass candle holder is in the shape of a cuboid with a cone removed. The cuboid measures 4cm by 4cm by 6cm.
- The cone has a diameter of 3cm and a height of 5cm.
- Calculate the volume of glass in the candle holder.

10. For the Christmas market a confectioner has created a chocolate Santa.
- It consists of a solid hemisphere topped by a solid cone.
- Both have diameter 5cm and the height of the cone is 4cm as shown in the diagram.

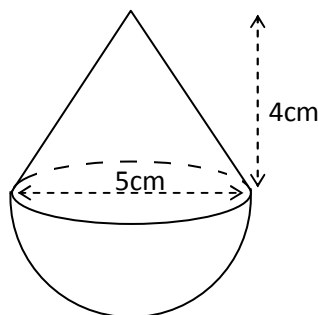

Calculate the volume of chocolate required to make one chocolate Santa, giving your answer correct to 3 significant figures.

11. The diameter of an ordinary snooker ball is 5.25cm.

Calculate the volume of a snooker ball giving your answer correct to 3 significant figures.

12. A dessert is in the shape of a truncated cone [a cone with a 'slice' taken from the top].

The radius of the base is 4.1cm and is 1.6 cm at the top.

The other dimensions are shown in the diagram.

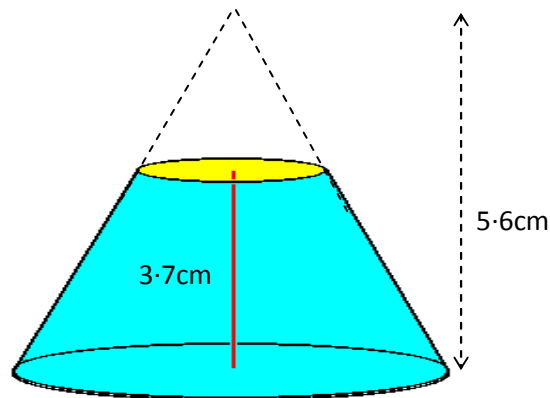

Calculate the volume of the dessert.

13. A young child was given a slab of moulding clay. It was a cuboid and measured 15.2cm by 4.8cm by 3.4cm.

(a) Calculate the volume of the cuboid rounding your answer to 2 significant figures.

The clay was made into 25 identical spheres.

(b) Using your answer from part (a), calculate the radius of one of the spheres.

14. An ice cream is shaped like the one in the diagram.
 The overall height of is 11.7 cm.
 The height of the cylinder is 3.2 cm.
 The diameter of the cone and cylinder is 6.6 cm.
 Calculate the volume of ice cream.

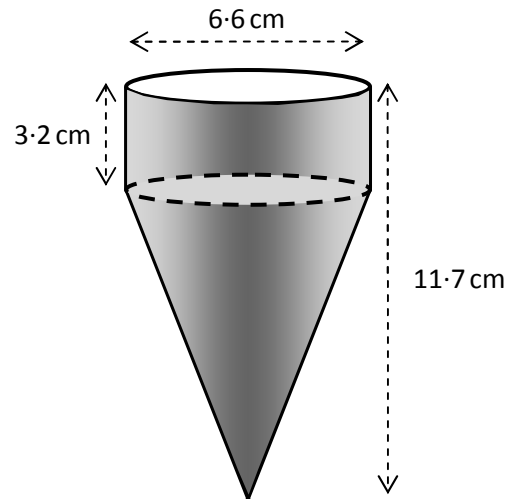

15. A company that produces bins uses the design of a cylindrical base with a hemispherical lid.

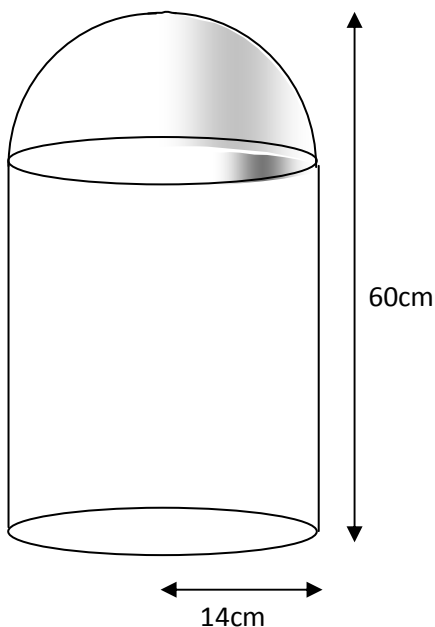

If the total height of the bin is 60cm and the radius of the bin is 14cm, calculate the total volume of the bin in litres correct to 3 significant figures.

(Volume of cylinder = $\pi r^2 h$;

Volume of sphere = $\frac{4}{3}\pi r^3$)



- 16.

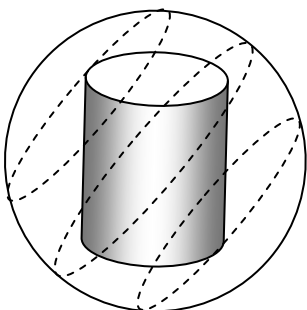

A Christmas bauble is made from a sphere of perspex with a coloured cylinder in the middle. The volume round the cylinder is filled with a thick liquid.

The sphere has a diameter of 8 cm. The cylinder has a radius of 2.6 cm with a height of 6 cm.

Calculate the volume of liquid needed to fill the sphere, giving your answer correct to 2 significant figures.

1.1 WORKING WITH SURDS

1. (a) $2\sqrt{2}$ (b) $2\sqrt{3}$ (c) $5\sqrt{2}$ (d) $2\sqrt{5}$ (e) $2\sqrt{6}$ (f) $6\sqrt{3}$
 (g) $2\sqrt{15}$ (h) $6\sqrt{2}$ (i) $10\sqrt{3}$ (j) $3\sqrt{3}$ (k) $4\sqrt{6}$ (l) $4\sqrt{3}$
 (m) $3\sqrt{5}$ (n) $7\sqrt{2}$ (o) $3\sqrt{10}$ (p) $3\sqrt{2}$ (q) $2\sqrt{7}$ (r) $4\sqrt{5}$
 (s) $4\sqrt{2}$ (t) $4\sqrt{10}$ (u) $5\sqrt{6}$ (v) $2\sqrt{11}$ (w) $3\sqrt{7}$ (x) $5\sqrt{7}$
2. (a) $10\sqrt{2}$ (b) $12\sqrt{2}$ (c) $10\sqrt{10}$ (d) $4\sqrt{3}$ (e) $12\sqrt{2}$ (f) $6\sqrt{6}$
 (g) $9\sqrt{3}$ (h) $40\sqrt{3}$ (i) $12\sqrt{3}$ (j) $9\sqrt{5}$ (k) $6\sqrt{7}$ (l) $8\sqrt{5}$
3. (a) $8\sqrt{2}$ (b) $2\sqrt{7}$ (c) $3\sqrt{3}$ (d) $4\sqrt{6}$ (e) $9\sqrt{3}$ (f) $6\sqrt{6}$
 (g) $3\sqrt{2}$ (h) $-6\sqrt{7}$ (i) 0 (j) $3\sqrt{5}$ (k) $-2\sqrt{3}$ (l) $11\sqrt{11}$
4. (a) $5\sqrt{3}$ (b) $2\sqrt{2}$ (c) $\sqrt{2}$ (d) $8\sqrt{2}$ (e) $6\sqrt{5}$ (f) $5\sqrt{6}$
 (g) $3\sqrt{5}$ (h) $7\sqrt{10}$ (i) $3\sqrt{2}$ (j) $-\sqrt{3}$ (k) $10\sqrt{3}$ (l) $7\sqrt{5}$
 (m) $8\sqrt{3}$ (n) $2\sqrt{2}$ (o) $\sqrt{2}$ (p) $8\sqrt{2}$ (q) $6\sqrt{5}$ (r) $5\sqrt{6}$
 (s) $7\sqrt{2}$ (t) $8\sqrt{3}$ (u) $4\sqrt{2}$
5. (a) 5 (b) 2 (c) 11 (d) a (e) 6 (f) c
 (g) k (h) $3\sqrt{2}$ (i) 4 (j) $2\sqrt{3}$ (k) $\sqrt{15}$ (l) \sqrt{xy}
 (m) 4 (n) 6 (o) 10 (p) 8 (q) \sqrt{ab} (r) $\sqrt{10x}$
 (s) \sqrt{pq} (t) $\sqrt{6k}$ (u) $2\sqrt{5}$ (v) $6\sqrt{2}$ (w) $5\sqrt{2}$ (x) $6\sqrt{2}$
 (y) $2\sqrt{15}$ (z) $4\sqrt{2}$
6. (a) 6 (b) 30 (c) $6\sqrt{14}$ (d) 24 (e) $3\sqrt{10}$ (f) $18\sqrt{2}$
 (g) $16\sqrt{6}$ (h) $15\sqrt{15}$
7. (a) 2 (b) $\frac{3}{2}$ (c) $\frac{1}{4}$ (d) $\frac{1}{3}$ (e) 2 (f) $\frac{1}{2}$
 (g) $\frac{3}{2}$ (h) $\frac{5}{3}$ (i) $\frac{1}{2}$ (j) $\frac{1}{3}$ (k) 6 (l) $\frac{10}{3}$
 (m) $2\sqrt{2}$ (n) $\frac{1}{2\sqrt{2}}$ (o) $\sqrt{14}$ (p) $\frac{1}{\sqrt{5}}$

8. (a) $\sqrt{2} - 2$ (b) $3 + \sqrt{3}$ (c) $5 - \sqrt{5}$ (d) $5\sqrt{2} + 2$
 (e) $3\sqrt{2} + 2\sqrt{3}$ (f) $4\sqrt{6} + 2\sqrt{3}$ (g) $3\sqrt{2} - 4\sqrt{6}$ (h) $5 + 2\sqrt{5}$
 (i) $48 - 16\sqrt{3}$ (j) $4 + 8\sqrt{2}$ (k) $12 + 12\sqrt{2}$ (l) $15\sqrt{10}$
 (m) $\sqrt{6} + \sqrt{3}$ (n) 6 (o) $\sqrt{6} + 3\sqrt{2}$ (p) $3\sqrt{5} - 5$

9. (a) $2\sqrt{2} - 1$ (b) $6 - 2\sqrt{5}$ (c) $16 + 11\sqrt{2}$ (d) 2
 (e) -1 (f) 1 (g) $10 - 13\sqrt{2}$ (h) $10 + 3\sqrt{8}$
 (i) $12 + 7\sqrt{6}$ (j) $11 + 6\sqrt{2}$ (k) $5 + 2\sqrt{6}$ (l) $13 - 4\sqrt{3}$
 (m) $30 - 4\sqrt{14}$ (n) $37 - 20\sqrt{3}$ (o) -2 (p) $8 + 2\sqrt{7}$
 (q) $8 + 4\sqrt{3}$ (r) -1

10. (a) $\frac{\sqrt{2}}{2}$ (b) $\frac{\sqrt{3}}{3}$ (c) $\frac{\sqrt{5}}{5}$ (d) $2\sqrt{3}$ (e) $2\sqrt{5}$ (f) $\frac{2\sqrt{3}}{3}$
 (g) $\frac{3\sqrt{5}}{5}$ (h) $10\sqrt{2}$ (i) $\sqrt{2}$ (j) $4\sqrt{3}$ (k) $\frac{\sqrt{6}}{2}$ (l) $\frac{4\sqrt{5}}{5}$
 (m) $5\sqrt{2}$ (n) $5\sqrt{7}$

11. (a) $\frac{\sqrt{5}}{10}$ (b) $\frac{2\sqrt{2}}{5}$ (c) $\frac{\sqrt{2}}{2}$ (d) $\frac{2\sqrt{6}}{5}$ (e) $\frac{4\sqrt{2}}{3}$ (f) $\frac{4\sqrt{5}}{7}$
 (g) $\frac{5\sqrt{10}}{3}$ (h) $\frac{5\sqrt{2}}{3}$

12. (a) $\frac{\sqrt{6}}{2}$ (b) $\frac{\sqrt{10}}{5}$ (c) 2 (d) $\sqrt{6}$
 (e) $\frac{1}{2}$ (f) $\frac{\sqrt{6}}{6}$ (g) $\sqrt{3}$ (h) $\frac{2\sqrt{3}}{3}$
 (i) $\frac{\sqrt{10}}{2}$ (j) $\frac{\sqrt{22}}{2}$ (k) $\frac{\sqrt{21}}{3}$ (l) $\frac{\sqrt{65}}{5}$
 (m) $\frac{2}{3}$ (n) $\frac{\sqrt{6}}{3}$ (o) $\frac{\sqrt{15}}{3}$ (p) $\frac{4\sqrt{15}}{15}$
 (q) $\frac{\sqrt{3}}{3}$ (r) $\sqrt{5}$ (s) $\frac{1}{2}$ (l) $\frac{\sqrt{10}}{2}$

13. (a) $\frac{\sqrt{2}}{10}$ (b) $2\sqrt{3}$ (c) $\frac{\sqrt{2}}{2}$ (d) $\frac{3\sqrt{5}}{10}$
 (e) $\sqrt{2}$ (f) $\frac{\sqrt{2}}{2}$ (g) $\frac{5\sqrt{3}}{3}$ (h) $\frac{3\sqrt{2}}{10}$

- (i) $\frac{\sqrt{2}}{2}$ (j) $\frac{\sqrt{2}}{3}$ (k) $\frac{\sqrt{3}}{2}$ (l) $\frac{2}{3}$
14. (a) $\sqrt{2+1}$ (b) $\frac{\sqrt{5}-1}{4}$ (c) $-12(2+\sqrt{3})$ (d) $-(1+\sqrt{2})$
- (e) $-\frac{1}{2}(1-\sqrt{3})$ (f) $\frac{3(\sqrt{5}+1)}{4}$ (g) $-(\sqrt{2}-2)$ (h) $-\frac{3}{2}(2+\sqrt{6})$
- (i) $\frac{5(3-\sqrt{2})}{7}$ (j) $-2(1+\sqrt{3})$ (k) $\frac{\sqrt{7}+2}{3}$ (l) $\sqrt{3}+\sqrt{2}$
- (m) $6(\sqrt{3}-\sqrt{2})$ (n) $\frac{3}{2}(\sqrt{10}+\sqrt{2})$ (o) $-3(\sqrt{5}-\sqrt{6})$ (p) $\frac{14(9+\sqrt{2})}{79}$

SURDS

1. (a) $3\sqrt{5}$ (b) $\sqrt{3}$ (c) $6\sqrt{5}$ (d) $2\sqrt{2}$
2. (a) 10 (b) -2 (c) 6 (d) $4\sqrt{2}$
3. (a) $4\sqrt{3}$ (b) 8 (c) $4\sqrt{15}$
4. (a) 2 cm^2 (b) $2\sqrt{3}\text{ cm}$
5. (a) 3 (b) 11
6. $8\sqrt{2}$
7. (a) $\sqrt{3}a$ (b) $\sqrt{3}a^2$
8. Proof 9. Proof

PROBLEMS

1.2 INDICES

1. (a) 3^6 (b) 2^4 (c) 10^7 (d) 8^8 (e) 7^7 (f) 5^8
- (g) 9^8 (h) 6^{13} (i) x^8 (j) c^{11} (k) a^{14} (l) y^{10}
- (m) b^{40} (n) p^{10} (o) d^6 (p) q^{20} (q) t^{10} (r) f^7
- (s) k^{13} (t) z^{100} (u) x^{80} (v) y^{20} (w) a^{90} (x) b^1
2. (a) 2^5 (b) 5^2 (c) 12^3 (d) 7^7 (e) 20^4 (f) 8^4
- (g) 3^{15} (h) 4^2 (i) x^5 (j) a^4 (k) y^{10} (l) b^3
- (m) p (n) 1 (o) q^6 (p) d^3 (q) x^6 (r) a^6
- (s) m^{13} (t) 1 (u) d^8 (v) y^{90} (w) t^{99} (x) w^{10}

3. (a) 3^8 (b) 8^4 (c) 10^6 (d) 2^{10} (e) 4^{15} (f) 1
 (g) 12^9 (h) 5^{25} (i) x^8 (j) y^{40} (k) a^{21} (l) m^{16}
 (m) b^{18} (n) p^{15} (o) k^{100} (p) 1
4. (a) $4b^2$ (b) $343a^3$ (c) $81x^4$ (d) $32y^5$ (e) a^4b^4 (f) x^7y^7
 (g) w^5z^5 (h) s^3t^3 (i) p^3q^6 (j) x^8y^2 (k) $a^{10}b^{15}$ (l) $36a^{10}$
 (m) $1000x^6$ (n) $32c^{20}$ (o) $27a^3b^6$ (p) $16m^4k^2$
5. (a) $10a^8$ (b) $63x^9$ (c) $3p^3$ (d) $5b^6$
 (e) $24y^7$ (f) $80q^{10}$ (g) $8c^7$ (h) $8z^4$
 (i) $k^5 + k^7$ (j) $m^7 - m^8$ (k) $2x^7 + 6x^6$ (l) $10a^7 - 15a^8$
 (m) x^3 (n) m^{14} (o) $10c^4$ (p) $6q^3$
 (q) $3xy^{14}$ (r) $4a^{10}b^{28}$ (s) $4p^3$ (t) $\frac{8}{3}a^2b^{12}$
6. (a) 1 (b) 1 (c) 1 (d) 1 (e) 1 (f) 1
 (g) 1 (h) 1 (i) 1 (j) 1 (k) 1 (l) 1
7. (a) $\frac{1}{3^2}$ (b) $\frac{1}{5^4}$ (c) $\frac{1}{2^6}$ (d) $\frac{1}{10^3}$ (e) $\frac{1}{4^5}$ (f) $\frac{1}{200^7}$
 (g) $\frac{1}{a^5}$ (h) $\frac{1}{x^2}$ (i) $\frac{1}{p^7}$ (j) $\frac{1}{y^{10}}$ (k) $\frac{2}{b^3}$ (l) $\frac{10}{q^x}$
 (m) x^3 (n) w^5 (o) $3a^2$ (p) $10c^8$ (q) $\frac{2}{3}t$ (r) $\frac{5}{4}y^3$
8. (a) 3^{-2} (b) 6^{-9} (c) 5^{-4} (d) 2^{-7} (e) 10^{-3} (f) 4^{-4}
 (g) x^{-3} (h) a^{-5} (i) p^{-4} (j) y^{-10} (k) q^{-6} (l) c^{-8}
9. (a) m^{-2} (b) x^5 (c) p^{-3} (d) a^{-8} (e) y^{-12} (f) c^{-15}
 (g) q^{-15} (h) w^8 (i) $20b$ (j) 27 (k) $2k^5$ (l) $1.5d^{-3}$
 (m) $x^5 + x$ (n) $p - p^{-11}$ (o) $6a^6 + 9a^3$ (p) $2m^{-5} - 5m^4$
 (q) v^{10} (r) $6h^{-1}$ (s) $6c^5$ (t) 10

10. (a) 2 (b) 2 (c) 6 (d) 9 (e) 4 (f) 10
 (g) 5 (h) 27 (i) 25 (j) 8 (k) 6 (l) $\frac{1}{2}$
 (m) $\frac{1}{2}$ (n) $\frac{1}{4}$ (o) $\frac{1}{3}$ (p) $\frac{1}{9}$ (q) $\frac{1}{64}$ (r) $\frac{1}{100}$
 (s) $\frac{1}{64}$ (t) $\frac{1}{16}$ (u) 16 (v) -2 (w) 16 (x) $\frac{1}{1000}$
 (y) 2 (z) $\frac{1}{16}$
11. (a) x^3 (b) p^2 (c) a^6 (d) $\frac{1}{y^6}$ (e) $\frac{1}{q^2}$ (f) $\frac{1}{k^5}$
 (g) g^2 (h) $\frac{1}{m^8}$ (i) c^6 (j) $\frac{1}{h^2}$ (k) $\frac{1}{z^3}$ (l) $\frac{1}{b^{12}}$
 (m) 1 (n) y (o) d^2 (p) s^3 (q) $12x$ (r) 12
 (s) $10x$ (t) $6x^{\frac{1}{3}}$ (u) 1 (v) $2x$ (w) $4x^{\frac{1}{3}}$ (x) $\frac{3}{2x^{\frac{1}{3}}}$
12. (a) \sqrt{x} (b) $\sqrt[3]{x}$ (c) $\sqrt[4]{a}$ (d) $\sqrt[3]{y^2}$
 (e) $\sqrt[4]{b^3}$ (f) $\sqrt[3]{x^5}$ (g) $\sqrt[5]{c^3}$ (h) $\sqrt[5]{a^4}$
 (i) $\frac{1}{\sqrt[3]{c}}$ (j) $\frac{1}{\sqrt{z}}$ (k) $\frac{1}{\sqrt[3]{m^2}}$ (l) $\frac{1}{\sqrt[5]{k^3}}$
 (m) $\frac{1}{\sqrt[3]{p^4}}$ (n) $\frac{1}{\sqrt[3]{x^5}}$ (o) $\frac{1}{\sqrt[5]{w^4}}$ (p) $\frac{1}{\sqrt[7]{d^2}}$
13. (a) $x^{\frac{1}{2}}$ (b) $a^{\frac{1}{3}}$ (c) $y^{\frac{3}{2}}$ (d) $z^{\frac{2}{3}}$ (e) $c^{\frac{2}{3}}$ (f) $x^{\frac{3}{4}}$
 (g) $p^{\frac{5}{3}}$ (h) $m^{\frac{2}{5}}$ (i) $a^{-\frac{1}{2}}$ (j) $z^{-\frac{1}{3}}$ (k) $x^{-\frac{4}{3}}$ (l) $a^{-\frac{1}{5}}$
 (m) $b^{-\frac{2}{3}}$ (n) $m^{-\frac{3}{5}}$ (o) $y^{-\frac{1}{4}}$ (p) $c^{-\frac{5}{3}}$
14. (a) $x^{\frac{9}{2}} + x^{\frac{1}{2}}$ (b) $x - x^{\frac{3}{2}}$ (c) $x^{-\frac{3}{2}} + x^{-1}$
 (d) $2x^5 + 2x^2$ (e) $x^{\frac{3}{2}} - 1$ (f) $x^4 + 2x + \frac{1}{x^2}$
 (g) $x^{-\frac{1}{2}} + 1$ (h) $x^2 + 2x^{\frac{1}{2}} + x^{-1}$ (i) $x^{-3} - x^{-\frac{5}{3}}$
 (j) $x + 3x^{-1}$ (k) $x^{-\frac{3}{2}} - x^{-1}$ (l) $4x^{\frac{1}{2}} + 4x^{-\frac{1}{2}} + x^{-\frac{3}{2}}$

INDICES EXAM QUESTIONS

1. (a) $7a^2b^{\frac{3}{2}}$ (b) 56 2. $\frac{1}{2}$ 3. $x^{\frac{4}{3}} + 1$
4. (a) m^8 (b) $\frac{1}{25}$ 5. $4p^9$ 6. $\frac{3}{a^2}$ 7. $\frac{1}{x^2}$ 8. a^{10}
9. (a) $p^3 - 2p^{\frac{1}{2}}$ (b) 60

1.2 CALCULATIONS USING SCIENTIFIC NOTATION

1. (a) The speed of light is 300 000 000 metres per second.
(b) The diameter of the earth is 12 680 kilometres.
(c) A Building Society has £2 150 000 000 in its funds.
(d) The radius of the orbit of an electron is 0.000 000 05 mm.
(e) A space probe reached a speed of 149 000 m.p.h.
(f) The earth weighs 6 600 000 000 000 000 000 tonnes.
(g) A film of oil is 0.000 000 08 mm thick.
2. (a) 8.8×10^{11} (b) 6.93×10^{15} (c) 4.14×10^7 (d) 1.365×10^{19}
(e) 6.86×10^{24} (f) 5.52×10^{12} (g) 1.19×10^7 (h) 6.24×10
(i) 6.351×10^{-4} (j) 9.09×10^{-38} (k) 5.5×10^6 (l) 6.3×10^{-10}
(m) 7.5×10^{15} (n) 9.3×10^5 (o) 1.3×10^7 (p) 2.5×10^{12}
(q) 1.7×10^{-9} (r) 1.4×10^{-33} (s) 8.9×10^8 (t) 1.05×10^{19}
(u) 3.2×10^4 (v) 1.39×10^5 (w) 9×10^{-6}
3. (a) 6.66×10^8 (b) 4.0506×10^4 (c) 2.94336×10^9
(d) 2×10^7 (e) 3×10^{30}
4. (a) 8.7×10^{-1} grams. (b) 2.52×10^7 (c) 1.943×10^8
(d) 1.794×10^{10} (e) $£2.016 \times 10^7$ (f) $£1.896 \times 10^6$
(g) 2.592×10^6 (h) 5.229×10^6 (i) 1.869×10^9

SCIENTIFIC NOTATION

EXAM QUESTIONS

1. 344 days 2. 1.35×10^{10} years 3. 1.27×10^9 4. 3.672×10^7

1.3 SIGNIFICANT FIGURES

1. (a) 20 (b) 6 (c) 80 (d) 30 (e) 100 (f) 300
(g) 300 (h) 800 (i) 8000 (j) 2000 (k) 8000 (l) 5000
(m) 11 (n) 600 (o) 4 (p) 10000 (q) 1 (r) 90
(s) 0.9 (t) 600
2. (a) 8.7 (b) 93 (c) 0.19 (d) 680 (e) 2.1 (f) 6.5
(g) 31 (h) 26 (i) 24 (j) 19 (k) 6400 (l) 5.0
(m) 0.053 (n) 0.0061 (o) 0.087 (p) 14000 (q) 2.5 (r) 45000
(s) 29 (t) 0.76
3. (a) 49.3 (b) 2.35 (c) 0.593 (d) 4770
(e) 6.08 (f) 24200 (g) 0.0628 (h) 29.5
(i) 0.00947 (j) 56200 (k) 0.0980 (l) 24.5
(m) 28.3 (n) 2460 (o) 3170 (p) 30.0
(q) 2.68 (r) 3090 (s) 2.01 (t) 0.000318
4. (a) 248400 (b) 248000 (c) 250000 (d) 200000
5. (a) 0.02860 (b) 0.0286 (c) 0.029 (d) 0.03
6. (a) 120 (b) 4.0 (c) 250 (d) 41
(e) 49 (f) 0.49 (g) 3.8 (h) 0.084
(i) 250 (j) 17 (k) 500 (l) 65
7. (a) 133 (b) 4.78 (c) 56.5 (d) 988
(e) 8.78 (f) 334 (g) 19.8 (h) 26.3
(i) 0.965 (j) 326 (k) 2.07 (l) 0.0965
8. 2.98×10^8

2.1 ALGEBRAIC EXPRESSIONS with BRACKETS

1. (a) $3x - 15$ (b) $5y + 35$ (c) $8a + 48$ (d) $18 + 6t$
(e) $x^2 + 9x$ (f) $3y - y^2$ (g) $b^2 - 4b$ (h) $5p + p^2$
(i) $ab + ac$ (j) $x^2 - xy$ (k) $pq - pr$ (l) $a^2 + ax$
2. (a) $8a + 20$ (b) $21y - 28$ (c) $24x + 22$ (d) $36c - 63$
(e) $2a^2 + 6a$ (f) $5x^2 - 40x$ (g) $30y - 10y^2$ (h) $3t^2 + 18t$
(i) $6x^2 - 27x$ (j) $14y - 10y^2$ (k) $12b^2 - 32b$ (l) $25x^2 + 20x$
3. (a) $11a - 3$ (b) $7x + 6$ (c) $8b + 7$ (d) $8h + 3$
(e) $15 - 9x$ (f) $6c - 5$ (g) $-2t + 6$ (h) $p^2 - 2pq$
(i) $-3 - 21c$ (j) $13 + 4x$ (k) $13a - 9$ (l) $19 - 4x$
(m) $-4 + 15y$ (n) $b + 2$ (o) $-13 - 15x$ (p) $-4x + 20$
(q) $-7c + 5$ (r) $31 - 10a$
4. (a) $x^2 + 5x + 6$ (b) $y^2 + 7y + 10$ (c) $a^2 + 10a + 24$
(d) $b^2 + 7b + 12$ (e) $x^2 + 14x + 45$ (f) $s^2 + 11s + 24$
(g) $y^2 + 11y + 28$ (h) $b^2 + 6b + 9$ (i) $c^2 + 13c + 42$
(j) $a^2 + 12a + 32$ (k) $y^2 + 6y + 8$ (l) $x^2 + 17x + 72$
(m) $p^2 + 19p + 84$ (n) $c^2 + 11c + 30$ (o) $t^2 + 16t + 63$
(p) $x^2 + 13x + 36$ (q) $y^2 + 17y + 60$ (r) $a^2 + 20a + 19$
5. (a) $x^2 - 6x + 5$ (b) $c^2 - 6c + 8$ (c) $y^2 - 10y + 21$
(d) $b^2 - 14b + 48$ (e) $x^2 - 7x + 10$ (f) $s^2 - 13s + 40$
(g) $y^2 - 11y + 18$ (h) $a^2 - 8a + 16$ (i) $t^2 - 9t + 18$
(j) $x^2 - 11x + 30$ (k) $b^2 - 8b + 15$ (l) $c^2 - 14c + 40$
(m) $a^2 - 12a + 27$ (n) $y^2 - 15y + 56$ (o) $x^2 - 15x + 36$
(p) $s^2 - 11s + 28$ (q) $d^2 - 16d + 15$ (r) $b^2 - 11b + 10$
6. (a) $x^2 + 4x - 5$ (b) $a^2 - 4a - 21$ (c) $t^2 - t - 20$
(d) $y^2 + 4y - 32$ (e) $c^2 - 5c - 14$ (f) $x^2 - 5x - 6$

- (g) $b^2 + 7b - 18$ (h) $p^2 - 8p - 20$ (i) $y^2 - y - 56$
(j) $z^2 - 2z - 24$ (k) $x^2 - 1$ (l) $a^2 - 13a - 30$
(m) $c^2 - 9$ (n) $p^2 - 6p - 7$ (o) $b^2 + 5b - 50$
7. (a) $x^2 + 6x + 9$ (b) $w^2 - 4w + 4$ (c) $a^2 - 10a + 25$
(d) $c^2 + 16c + 64$ (e) $y^2 - 8y + 16$ (f) $a^2 + 12a + 36$
(g) $b^2 + 2b + 1$ (h) $s^2 + 14s + 49$ (i) $b^2 - 18b + 81$
(j) $x^2 - 20x + 100$ (k) $c^2 - 2c + 1$ (l) $y^2 - 6y + 9$
(m) $4x^2 - 4x + 1$ (n) $25y^2 + 20y + 4$ (o) $9x^2 + 24x + 16$
(p) $16b^2 - 40b + 25$
8. (a) $ac + bc + ad + bd$ (b) $6 + 3x + 2y + xy$ (c) $ab + 4b + 5a + 20$
(d) $pr - qr - ps + qs$ (e) $7 - 7a - b + ab$ (f) $cd - 6d + 8c - 48$
9. (a) $x^3 + x^2 - x$ (b) $6x^2 - 9x + 15$ (c) $3x^3 - 5x^2 + 8x$
(d) $2x^3 + 4x^2 + 6x$ (e) $-5x^2 + 40x - 10$ (f) $x^3 - 4x^2 - 7x$
10. (a) $x^3 + 5x^2 + 7x + 2$ (b) $x^3 + 9x^2 + 22x + 10$
(c) $x^3 + 6x^2 + 9x + 4$ (d) $x^3 + 4x^2 + 8x + 15$
(e) $x^3 + 10x^2 + 19x + 24$ (f) $x^3 + 11x^2 + 34x + 24$
(g) $x^3 + 13x^2 + 19x + 84$ (h) $x^3 + 13x^2 + 39x + 90$
(i) $x^3 + 21x^2 + 115x + 63$ (j) $x^3 + 16x^2 + 64x + 7$
(k) $x^3 - 2x^2 - 13x + 6$ (l) $x^3 - 7x^2 + 17x - 66$
(m) $x^3 - 6x^2 - 13x + 6$ (n) $x^3 - x^2 - 23x + 35$
(o) $x^3 + 13x^2 + 24x - 60$ (p) $x^3 + 14x^2 + 39x - 54$
(q) $x^3 + 12x^2 + 9x - 22$ (r) $x^3 + 15x^2 + 53x - 21$
11. (a) $x^3 - 1$ (b) $x^3 - 4x^2 - 16x - 35$
(c) $x^3 + 2x^2 - 5x - 6$ (d) $x^3 + 2x^2 - 23x - 4$
(e) $x^3 - 5x^2 + 11x - 15$ (f) $x^3 - 11x^2 + 32x - 12$
(g) $x^3 - 5x^2 + 6x - 8$ (h) $x^3 - 3x^2 + 9x - 7$
(i) $x^3 - 6x^2 - 29x + 18$ (j) $x^3 + 3x^2 - 34x - 30$
(k) $x^3 - 7x^2 - 15x + 56$ (l) $x^3 + 6x^2 - 39x + 36$
(m) $x^3 - 9x^2 + 19x + 5$ (n) $x^3 - 13x^2 + 22x + 80$
(o) $x^3 - 13x^2 + 40x + 12$ (p) $x^3 - 18x^2 + 4x + 13$

12. (a) $2x^3 + 14x^2 + 29x + 45$ (b) $5x^3 - 14x^2 + 3x - 18$
 (c) $6x^3 - 17x^2 + 17x - 14$ (d) $3x^3 + 30x^2 + 61x - 14$
 (e) $5x^3 - 21x^2 - 4x + 32$ (f) $7x^3 + 5x^2 + 9x + 11$
 (g) $6x^3 + 11x^2 + 6x + 1$ (h) $3x^3 - 29x^2 - 38x + 8$
 (i) $10x^3 + 11x^2 - 41x + 14$ (j) $12x^3 - 29x^2 - x + 12$
13. (a) $x^2 + 7x - 8$ (b) $4x^2 - x - 3$ (c) $4x^2 + 8x + 5$
 (d) $-x^2 - 4$ (e) $12x - 3$ (f) $-9x - 22$
 (g) $2x^2 - 10x + 8$ (h) $5x^2 - x + 2$ (i) $21 + 8x - 4x^2$
 (j) $3x^3 + 20x^2 + 21x$ (k) $2x^3 - x^2 - 2x + 9$ (l) $1 - 3x - x^2 - x^3$

2.1 FACTORISING an ALGEBRAIC EXPRESSION

1. (a) $2(x + y)$ (b) $3(c + d)$ (c) $6(s + t)$ (d) $12(x + y)$
 (e) $9(a + b)$ (f) $8(b + c)$ (g) $5(p + q)$ (h) $7(g + h)$
 (i) $4(m + n)$ (j) $9(e + f)$ (k) $13(j + k)$ (l) $14(v + w)$
2. (a) $2(x + 2)$ (b) $3(d + 3)$ (c) $3(2s + 1)$ (d) $4(3x + 1)$
 (e) $3(2 + 3a)$ (f) $2(b + 4)$ (g) $5(y + 2)$ (h) $5(2 + 3c)$
 (i) $4(3x + 4)$ (j) $6(3m + 4)$ (k) $6(5 + 6a)$ (l) $7(2y + 3)$
3. (a) $3(x - 2)$ (b) $4(y - 2)$ (c) $8(2 - a)$ (d) $5(2c - 3)$
 (e) $3(3s - 4)$ (f) $2(b - 7)$ (g) $4(3x - 5)$ (h) $11(2m - 3)$
 (i) $5(3x - 2)$ (j) $6(3 - 2y)$ (k) $5(5b - 4)$ (l) $6(3d - 5)$
4. (a) $2(a + 2b)$ (b) $2(5x - 6y)$ (c) $6(3m + 4n)$ (d) $5(2c + 3d)$
 (e) $3(2a - 3x)$ (f) $6(3s - 2t)$ (g) $3(4x + 5y)$ (h) $7(2a - b)$
 (i) $5(5c + 2d)$ (j) $3(3b - 5y)$ (k) $6(3x + 4y)$ (l) $2(3a + 14b)$
5. (a) $a(x + y)$ (b) $x(y^2 + a^2)$ (c) $p(qr + st)$
 (d) $a(xy - bc)$ (e) $p(q + 1)$ (f) $y(y + 1)$
 (g) $a(a - b)$ (h) $b(a - c)$ (i) $n(n - 3)$
 (j) $y(x + y)$ (k) $ab(c - d)$ (l) $fg(h - e)$
6. (a) $2a(x + 3)$ (b) $3y(1 + 3y)$ (c) $8a(3 - 2b)$
 (d) $pq(q - 1)$ (e) $3x(4y - 3z)$ (f) $2b(3b - 2)$
 (g) $3a(a + 9h)$ (h) $5ab(3c + 4d)$ (i) $3s^2(s - 3)$
 (j) $2x(7 - 6yz)$ (k) $5bc(2b - 3d)$ (l) $2\pi r(r + h)$

7. (a) $a(p + q - r)$ (b) $2(a + b + c)$ (c) $2(3e - f + 2g)$
 (d) $p(p + q + x)$ (e) $3b(a - 2c - 3d)$ (f) $\frac{1}{2}h(a + b + c)$
 (g) $x(5x - 8y + 5)$ (h) $2a(2c + 3d - 5a)$ (i) $5p(3p + 2q + 4s)$
8. (a) $(a - b)(a + b)$ (b) $(x - y)(x + y)$ (c) $(p - q)(p + q)$
 (d) $(s - t)(s + t)$ (e) $(a - 3)(a + 3)$ (f) $(x - 2)(x + 2)$
 (g) $(p - 9)(p + 9)$ (h) $(c - 5)(c + 5)$ (i) $(b - 1)(b + 1)$
 (j) $(y - 4)(y + 4)$ (k) $(m - 5)(m + 5)$ (l) $(a - 3)(a + 3)$
 (m) $(6 - d)(6 + d)$ (n) $(2 - q)(2 + q)$ (o) $(7 - w)(7 + w)$
 (p) $(x - 8)(x + 8)$
9. (a) $(a - 2b)(a + 2b)$ (b) $(x - 5y)(x + 5y)$ (c) $(p - 8q)(p + 8q)$
 (d) $(4c - d)(4c + d)$ (e) $(9 - 2g)(9 + 2g)$ (f) $(6w - y)(6w + y)$
 (g) $(2a - 1)(2a + 1)$ (h) $(g - 9h)(g + 9h)$ (i) $(7x - y)(7x + y)$
 (j) $(3c - 4d)(3c + 4d)$ (k) $(2p - 3q)(2p + 3q)$ (l) $(b - 10c)(b + 10c)$
 (m) $(5 - 4a)(5 + 4a)$ (n) $(2d - 11)(2d + 11)$ (o) $(15 - 7k)(15 + 7k)$
 (p) $(3x - 0.5)(3x + 0.5)$
10. (a) $2(a - b)(a + b)$ (b) $5(p - 1)(p + 1)$ (c) $5(3 - x)(3 + x)$
 (d) $4(d - 3)(d + 3)$ (e) $2(y - 5)(y + 5)$ (f) $4(b - 5)(b + 5)$
 (g) $3(q - 3)(q + 3)$ (h) $8(a - 2b)(a + 2b)$ (i) $a(b - 8)(b + 8)$
 (j) $x(y - 5)(y + 5)$ (k) $ab(c - 1)(c + 1)$ (l) $2(2p - 5q)(2p + 5q)$
 (m) $2(x - 1.2)(x + 1.2)$ (n) $a(k - 11)(k + 11)$ (o) $2.5(2s - 1)(2s + 1)$
 (p) $\frac{1}{2}(y - 30)(y + 30)$
11. (a) $(x + 1)(x + 2)$ (b) $(a + 1)(a + 1)$ (c) $(y + 1)(y + 4)$
 (d) $(x + 7)(a + 1)$ (e) $(x + 3)(x + 3)$ (f) $(b + 6)(b + 2)$
 (g) $(a + 7)(a + 2)$ (h) $(w + 1)(a + 9)$ (i) $(d + 5)(d + 2)$
 (j) $(x + 7)(x + 3)$ (k) $(p + 4)(p + 5)$ (l) $(c + 4)(c + 6)$
 (m) $(s + 6)(s + 6)$ (n) $(x + 7)(x + 4)$ (o) $(y + 5)(y + 5)$
12. (a) $(a - 5)(a - 3)$ (b) $(x - 1)(x - 8)$ (c) $(a - 6)(a - 3)$
 (d) $(y - 2)(y - 2)$ (e) $(b - 5)(b - 1)$ (f) $(x - 14)(x - 1)$
 (g) $(c - 2)(c - 8)$ (h) $(x - 6)(x - 1)$ (i) $(y - 4)(y - 8)$
 (j) $(p - 8)(p - 3)$ (k) $(a - 9)(a - 4)$ (l) $(x - 3)(x - 12)$
 (m) $(b - 1)(b - 3)$ (n) $(q - 10)(q - 1)$ (o) $(a - 4)(a - 3)$

13. (a) $(b + 5)(b - 2)$ (b) $(x + 7)(x - 1)$ (c) $(y + 2)(y - 3)$
 (d) $(a + 4)(a - 5)$ (e) $(q + 4)(q - 2)$ (f) $(x + 2)(x - 10)$
 (g) $(d + 7)(d - 3)$ (h) $(c + 12)(c - 3)$ (i) $(p + 3)(p - 8)$
 (j) $(y + 1)(y - 8)$ (k) $(a + 6)(a - 1)$ (l) $(x + 4)(x - 9)$
 (m) $(b + 1)(b - 5)$ (n) $(s + 6)(s - 4)$ (o) $(d + 8)(d - 2)$
14. (a) $(3x + 1)(x + 2)$ (b) $(2a + 1)(a + 2)$ (c) $(3c + 5)(c + 1)$
 (d) $(2p + 9)(p + 1)$ (e) $(2y + 1)(y + 5)$ (f) $(3d + 2)(d + 3)$
 (g) $(5q + 4)(q + 1)$ (h) $(2b + 3)(2b + 1)$ (i) $(3x + 2)(2x + 3)$
 (j) $(3a + 5)(a + 3)$ (k) $(5x + 1)(2x + 3)$ (l) $(3c + 1)(3c + 1)$
 (m) $(3y + 1)(2y + 3)$ (n) $(3b + 2)(b + 1)$ (o) $(4x + 1)(2x + 3)$
15. (a) $(2x - 1)(x - 3)$ (b) $(2a - 3)(a - 1)$ (c) $(5p - 2)(p - 3)$
 (d) $(5b - 2)(b - 1)$ (e) $(3x - 2)(2x - 1)$ (f) $(4y - 3)(y - 2)$
 (g) $(7c - 1)(c - 4)$ (h) $(4m - 1)(m - 2)$ (i) $(8a - 1)(2a - 1)$
 (j) $(4y - 1)(2y - 5)$ (k) $(3p - 1)(p - 12)$ (l) $(4x - 1)(x - 6)$
 (m) $(5a - 2)(3a - 2)$ (n) $(6c - 1)(4c - 3)$ (o) $(3b - 4)(2b - 9)$
16. (a) $(3x + 1)(x - 1)$ (b) $(a + 1)(2a - 3)$ (c) $(4p + 3)(p - 1)$
 (d) $(c + 4)(2c - 1)$ (e) $(6y + 1)(y - 2)$ (f) $(3w - 2)(w + 4)$
 (g) $(3m + 5)(m - 1)$ (h) $(q + 2)(4q - 3)$ (i) $(2b + 5)(3b - 4)$
 (j) $(2t + 1)(2t - 3)$ (k) $(2z + 3)(6z - 1)$ (l) $(2d + 3)(2d - 5)$
 (m) $(7s + 1)(s - 4)$ (n) $(3x + 5)(5x - 3)$ (o) $(4v + 1)(9v - 2)$
 (p) $(3v + 7)(v + 1)$ (q) $(2l - 1)(l - 5)$ (r) $(3m - 7)(4m - 1)$
 (s) $(3n - 7)(n - 4)$ (t) $(2b - 5)(2b - 5)$ (u) $(3c + 4)(3c + 2)$
 (v) $(3q - 1)(q + 5)$ (w) $(2a + 3)(3a - 4)$ (x) $(4b + 5)(2b - 3)$
 (y) $(6m + 5)(2m - 3)$ (z) $(2n + 7)(n - 4)$
17. (a) $3(x - 1)(x + 1)$ (b) $2(p + 5)(p + 1)$ (c) $9(x - 2)(x + 2)$
 (d) $5(x + 2)(x + 3)$ (e) $a(x + 2)(x + 3)$ (f) $3(y - 5)(y + 1)$
 (g) $3(5c + 4)(c + 1)$ (h) $2(4b + 1)(2b + 3)$ (i) $3(3q + 2)(q + 3)$
 (j) $5(2s - 1)(s - 3)$ (k) $4(2m - 3)(m - 1)$ (l) $4(2a - 3)(a - 3)$
 (m) $2(2t - 7)(t + 4)$ (n) $10(3d + 2)(3d - 4)$ (o) $4(10x - 1)(10x + 1)$

2.3 COMPLETING THE SQUARE

1. (a) $(x+2)^2 - 4$ [-4] (b) $(x+5)^2 - 25$ [-25] (c) $(x+3 \cdot 5)^2 - 12 \cdot 25$ [-12·25]
(d) $(x+4 \cdot 5)^2 - 20 \cdot 25$ [-20·25] (e) $(x-3)^2 - 9$ [-9] (f) $(x-4)^2 - 16$ [-16]
(g) $(x-2 \cdot 5)^2 - 6 \cdot 25$ [-6·25] (h) $(x-5 \cdot 5)^2 - 30 \cdot 25$ [-30·25]
2. (a) $(x-1)^2 + 6$ [6] (b) $(x+3)^2 - 7$ [-7] (c) $(x+4)^2 - 7$ [-7]
(d) $(x+5)^2 + 2$ [2] (e) $(x+2)^2 - 12$ [-12] (f) $(x+8)^2 - 67$ [-67]
(g) $(x-3)^2 + 2$ [2] (h) $(x-1)^2 + 4$ [4] (i) $(x-4)^2 - 8$ [-8]
(j) $(x-7)^2 - 64$ [-64] (k) $(x-6)^2 - 15$ [-15] (l) $(x-10)^2 - 106$ [-106]
3. (a) $5 - (x-1)^2$ [5] (b) $11 - (x-2)^2$ [11] (c) $12 - (x+3)^2$ [12]
(d) $35 - (x+5)^2$ [35] (e) $16 \cdot 25 - (x-1 \cdot 5)^2$ [16·25] (f) $17 \cdot 25 - (x+3 \cdot 5)^2$ [17·25]

2.4 REDUCING an ALGEBRAIC FRACTION to SIMPLEST FORM

1. (a) $\frac{1}{2}$ (b) $\frac{2}{3}$ (c) $\frac{15}{8}$ (d) $\frac{3}{4}$ (e) $2a$ (f) $\frac{3b}{2}$
(g) $\frac{3}{2x}$ (h) $\frac{5}{3y}$ (i) $\frac{1}{4c}$ (j) $\frac{4}{a^2}$ (k) $\frac{1}{4p}$ (l) $\frac{6a}{c}$
(m) $\frac{2}{a}$ (n) $\frac{5x}{6y}$ (o) $\frac{v}{3t}$ (p) $\frac{5b^2}{a}$ (q) $\frac{6p}{5q}$ (r) $\frac{27x^2}{2}$
(s) $\frac{3n}{4}$ (t) $\frac{4df}{5e}$ (u) $\frac{3b^2}{4a}$ (v) $\frac{k}{7m}$ (w) $\frac{1}{2eg}$ (x) $\frac{7y^2}{12x^2}$
2. (a) $\frac{a+2b}{2}$ (b) $2(2x+3y)$ (c) $\frac{3+a}{b}$ (d) $\frac{x+y}{2}$
(e) $\frac{y+x}{6+y}$ (f) $\frac{a+2b}{3b}$ (g) $\frac{5b+3b^2}{2}$ (h) $\frac{7p+5q}{s}$
(i) $\frac{3}{2b-c}$ (j) $\frac{2x}{3(x+y)}$ (k) $\frac{t}{3r-t}$ (l) $\frac{1}{2a+3b}$
(m) $\frac{7p}{4}$ (n) $\frac{4}{3a}$ (o) $\frac{2n}{3}$ (p) $\frac{3x}{2}$

3. (a) $b-2$ (b) $x+9$ (c) $a-5$ (d) $y-6$ (e) $\frac{c+7}{2}$ (f) $\frac{a-8}{2}$
 (g) $\frac{p+1}{5}$ (h) $\frac{q-3}{3}$ (i) $\frac{a-b}{3}$ (j) $\frac{x+y}{5}$ (k) $m-3$ (l) $\frac{d+4}{4}$
 (m) $x+2$ (n) $\frac{1}{p-1}$ (o) $\frac{a}{x+5}$ (p) $\frac{a-1}{a+1}$ (q) $\frac{b-3}{b+3}$ (r) $\frac{c-3}{c-5}$
 (s) $\frac{3x-1}{x-2}$ (t) $\frac{y+2}{y-3}$ (u) $\frac{p-5}{p+1}$ (v) $\frac{c-4}{c-7}$ (w) $\frac{2x+1}{x+3}$ (x) $\frac{2a-5}{a-4}$
 (y) $\frac{5b+1}{5b-1}$

2.5 APPLYING the FOUR OPERATIONS to ALGEBRAIC FRACTIONS

1. (a) $\frac{4}{5}$ (b) $\frac{1}{2}$ (c) $\frac{7}{8}$ (d) $\frac{5}{6}$ (e) $\frac{7}{9}$ (f) $\frac{7}{12}$
 (g) $\frac{17}{20}$ (h) $\frac{5}{12}$ (i) $\frac{23}{24}$ (j) $\frac{9}{10}$ (k) $\frac{11}{12}$ (l) $\frac{13}{14}$
 (m) $\frac{23}{56}$ (n) $\frac{23}{40}$ (o) $\frac{41}{63}$ (p) $\frac{19}{21}$

2. (a) $\frac{1}{2}$ (b) $\frac{1}{3}$ (c) $\frac{1}{6}$ (d) $\frac{1}{12}$ (e) $\frac{1}{4}$ (f) $\frac{7}{16}$
 (g) $\frac{5}{12}$ (h) $\frac{1}{10}$ (i) $\frac{3}{10}$ (j) $\frac{11}{16}$ (k) $\frac{7}{12}$ (l) $\frac{1}{4}$
 (m) $\frac{9}{40}$ (n) $\frac{7}{30}$ (o) $\frac{22}{63}$ (p) $\frac{3}{16}$

3. (a) $\frac{1}{7}$ (b) $\frac{1}{10}$ (c) $\frac{2}{7}$ (d) $\frac{1}{12}$ (e) $\frac{1}{20}$ (f) $\frac{4}{7}$
 (g) $\frac{2}{7}$ (h) $\frac{1}{14}$ (i) $\frac{3}{8}$ (j) $\frac{4}{39}$ (k) $\frac{3}{40}$ (l) $\frac{2}{3}$
 (m) $\frac{4}{15}$ (n) $\frac{3}{4}$ (o) $\frac{10}{27}$ (p) $\frac{11}{24}$

4. (a) $\frac{3}{4}$ (b) $\frac{7}{5}$ (c) $\frac{16}{15}$ (d) $\frac{15}{14}$ (e) $\frac{1}{4}$ (f) $\frac{5}{3}$
 (g) $\frac{4}{9}$ (h) $\frac{6}{11}$ (i) $\frac{2}{3}$ (j) $\frac{1}{2}$ (k) $\frac{18}{25}$ (l) $\frac{8}{15}$
 (m) $\frac{16}{27}$ (n) $\frac{15}{28}$ (o) $\frac{16}{9}$ (p) $\frac{14}{15}$

5. (a) $\frac{2a}{5}$ (b) $\frac{b}{2}$ (c) $\frac{7x}{8}$ (d) $\frac{5p}{6}$ (e) $\frac{7y}{9}$ (f) $\frac{5}{m}$
- (g) $\frac{6}{x}$ (h) $\frac{9}{2a}$ (i) $\frac{13}{3y}$ (j) $\frac{43}{5p}$ (k) $\frac{3b+2a}{ab}$ (l) $\frac{5y+3x}{xy}$
- (m) $\frac{2n+7m}{mn}$ (n) $\frac{4q+3p}{pq}$ (o) $\frac{9d+7c}{cd}$ (p) $\frac{9y+4x}{6xy}$
- (q) $\frac{8b+15a}{6ab}$ (r) $\frac{2b+9a}{3ab}$ (s) $\frac{5n+6m}{4mn}$ (t) $\frac{7q+p}{3pq}$
- (u) $\frac{2+a}{a^2}$ (v) $\frac{5+3x}{x^2}$ (w) $\frac{b+4}{b^2}$ (x) $\frac{12m+5}{3m^2}$
6. (a) $\frac{2a}{5}$ (b) $\frac{3b}{10}$ (c) $\frac{5x}{8}$ (d) $\frac{p}{6}$ (e) $\frac{2y}{9}$ (f) $\frac{3}{m}$
- (g) $\frac{4}{x}$ (h) $\frac{9}{2a}$ (i) $\frac{2}{3y}$ (j) $\frac{37}{5p}$ (k) $\frac{3b-2a}{ab}$ (l) $\frac{5y-3x}{xy}$
- (m) $\frac{7n-2m}{mn}$ (n) $\frac{4q-3p}{pq}$ (o) $\frac{9d-7c}{cd}$ (p) $\frac{9y-4x}{6xy}$
- (q) $\frac{10b-9a}{6ab}$ (r) $\frac{5b-2a}{3ab}$ (s) $\frac{5n-6m}{4mn}$ (t) $\frac{7q-p}{3pq}$
- (u) $\frac{a-2}{a^2}$ (v) $\frac{7-3x}{x^2}$ (w) $\frac{4b-9}{3b^2}$ (x) $\frac{21-8p}{6p^2}$
7. (a) $\frac{x^2}{18}$ (b) $\frac{y^2}{8}$ (c) $\frac{ab}{14}$ (d) $\frac{pq}{24}$ (e) $\frac{c^3}{30}$ (f) $\frac{12}{a^2}$
- (g) $\frac{30}{xy}$ (h) $\frac{12}{p^2}$ (i) $\frac{8}{15m^2}$ (j) $\frac{11}{3bc}$ (k) $\frac{5}{4}$ (l) $\frac{20}{21}$
- (m) $\frac{8}{15y}$ (n) $\frac{2}{7a^3}$ (o) $\frac{10}{3p^4}$ (p) $\frac{s}{5t}$ (q) $\frac{15}{8q}$ (r) $\frac{7b^2c^2}{9a}$
- (s) $\frac{8m^3}{5n^3}$ (t) $\frac{2z^2}{3y^2}$ (u) $\frac{5a^2b^2}{2p^3}$ (v) $\frac{3a}{14d}$ (w) $8x^2y$ (x) $\frac{3}{2s^2t^2}$
- (y) $\frac{8q^2a}{5p^2}$
8. (a) $\frac{1}{2}$ (b) $\frac{x}{y}$ (c) $\frac{2b}{5}$ (d) $\frac{p}{2}$ (e) $\frac{4}{c}$ (f) $\frac{1}{2}$
- (g) $\frac{m}{2k}$ (h) $\frac{y}{3}$ (i) $\frac{2}{b}$ (j) $\frac{x}{8}$ (k) $\frac{18}{25}$ (l) $\frac{8pq}{15}$
- (m) $\frac{16a^2}{27}$ (n) $\frac{15}{28n^3}$ (o) $\frac{16a^2y}{9}$

$$\begin{array}{llll}
 \text{9. (a)} & \frac{3x+7}{6} & \text{(b)} & \frac{7a+10}{12} & \text{(c)} & \frac{2d-11}{6} & \text{(d)} & \frac{6a-13}{20} \\
 \text{(e)} & \frac{3a+4b}{4} & \text{(f)} & \frac{5u+7v}{12} & \text{(g)} & \frac{5x+13}{(x+3)(x+2)} & \text{(h)} & \frac{9x+29}{(x+5)(x+1)} \\
 \text{(i)} & \frac{11x+2}{(x-3)(x+2)} & \text{(j)} & \frac{-x-18}{(x+4)(x-3)} & \text{(k)} & \frac{13-4x}{(x-3)(x-2)} & \text{(l)} & \frac{7-x}{(x-5)(x-4)}
 \end{array}$$

ALGEBRAIC FRACTIONS

EXAM QUESTIONS

$$\begin{array}{lll}
 \text{1.} & \frac{9x+8}{x(x+2)} & \text{2.} & \frac{x-1}{(2x+3)} & \text{3.} & \frac{3e}{e+1} \\
 \text{4.} & \frac{-2x-13}{(x-1)(x+2)} & \text{5.} & \frac{3x}{5} & \text{6.} & \frac{x-15}{x(x-5)}
 \end{array}$$

3.1 DETERMINING the GRADIENT of a STRAIGHT LINE given TWO POINTS

1. (a) (i) 2 (ii) $-\frac{1}{2}$ (iii) $\frac{4}{3}$ (iv) $-\frac{1}{6}$ (v) 1
(b) 0; undefined; positive; negative
2. (a) 1 (b) 2 (c) $\frac{2}{3}$ (d) 5 (e) $\frac{1}{3}$ (f) $\frac{3}{2}$
(g) -3 (h) $-\frac{1}{2}$ (i) $-\frac{3}{2}$ (j) -1 (k) -6 (l) $-\frac{1}{8}$
3. (a) -3 (b) $\frac{1}{2}$ (c) 1 (d) $-\frac{1}{2}$ (e) $\frac{2}{5}$ (f) 4
4. (a) $\frac{1}{2}$ (b) -2 (c) 3 (d) 2 (e) -4 (f) $\frac{1}{2}$
(g) $\frac{3}{2}$ (h) $-\frac{1}{2}$ (i) $-\frac{3}{4}$ (j) 5 (k) 4 (l) $-\frac{5}{2}$
5. (a) $\frac{1}{5}$ (b) 2 (c) -2 (d) 1 (e) $-\frac{3}{4}$ (f) $\frac{5}{3}$
(g) $-\frac{2}{5}$ (h) $-\frac{11}{7}$ (i) $\frac{1}{11}$ (j) $\frac{4}{3}$ (k) $-\frac{12}{7}$ (l) 1
(m) $\frac{13}{9}$ (n) $-\frac{13}{5}$ (o) $-\frac{7}{6}$ (p) $\frac{14}{11}$
6. (a) both gradients $\frac{1}{2}$ (b) both gradients $-\frac{3}{2}$
(c) both gradients $\frac{1}{6}$ (d) both gradients $-\frac{4}{3}$
7. (a) $k=2$ (b) $k=-3$ (c) $k=-4$ (d) $k=5$
8. $a=-9$ 9. $k=2.5$ 10. $a=-30$ 11. $k=1$ 12. $k=19$

3.2 WORKING with the AREA of a SECTOR of a CIRCLE

1. (a) 50.2cm^2 (b) 239mm^2 (c) 1.22m^2
2. (a) 19.6cm^2 (b) 7.07cm^2 (c) 84.8cm^2 (d) 12.8cm^2
(e) 4.88cm^2 (f) 100cm^2 (g) 83.7cm^2 (h) 62.8cm^2
3. (a) 58.9cm^2 (b) 21.2cm^2 (c) 170cm^2 (d) 141cm^2
(e) 7.68cm^2 (f) 352cm^2 (g) 117cm^2 (h) 251cm^2
4. 12.8cm^2

3.2 WORKING with the ARCS and SECTORS of a CIRCLE EXAM QUESTIONS

1. 54.4cm^2 2. 6.83m 3. 7770cm^2 4. 27cm 5. 11.2m^2
6. 33.1cm^2 7. 206cm^2 8. 40°
9. (a) 173cm^2 (b) 56.5cm 10. 25.1cm^2 11. 90°
12. (a) 272m (b) 4470m^2 13. (a) 83.4cm (b) 151cm^2
14. (a) 1320cm^2 (b) 177cm 15. 20° 16. 25.1cm
17. 60.5°
18. (a) 57.3° (b) 89.6° (c) 12.2mm (d) 9.58cm

WORKING with VOLUME of a CYLINDER

1. (a) 1696.5cm^3 (b) 4825.5cm^3 (c) 603.2cm^3 (d) 2513.3cm^3 (e) 75398.2cm^3
(f) 3078.8cm^3 (g) 28274.3cm^3 (h) 13304.6cm^3 (i) 760265cm^3 (j) 7298.5cm^3
2. (a) 19.8cm (b) 3.7 litres 3. 904cm^3
4. No; volume is 9.72 litres

3.3 WORKING with the VOLUME of a SOLID SPHERE, CONE, PYRAMID

1. (a) 904.3cm^3 (b) 33.5m^3 (c) 3052.1mm^3 (d) 113.0cm^3
2. (a) 4190cm^3 (b) 65400cm^3 (c) 4.19m^3 (d) 33500000mm^3
(e) 697cm^3 (f) 3050cm^3 (g) 2140000mm^3 (h) 87100cm^3
(i) 180m^3 (j) 57900cm^3
3. 268cm^3
4. (a) 366cm^3 (b) 1280cm^3 (c) 207cm^3 (d) 1060cm^3
5. (a) 2369cm^3 (b) 1170cm^3 (c) 15800cm^3 (d) 608cm^3
6. (a) 56.5cm^3 (b) 803.8mm^3 (c) 47.1cm^3 (d) 25.1cm^3
7. 83.7cm^3 8. 314cm^3 9. 1020cm^3 10. 37cm^3
11. 640mm^3

WORKING with the VOLUME of a SOLID SPHERE, CONE, PYRAMID and CYLINDER

EXAM QUESTIONS

1. $2.79 \times 10^6 \text{m}^3$ 2. 6.01cm^3 3. 10cm 4. 113.04m^3
5. 6.11cm 6. 3140cm^3 7. 4291cm^3 8. 25900cm^3
9. 84.225cm^3 10. 58.9cm^3 11. 75.7cm^3 12. 93.4cm^3
13. (a) 250cm^3 (b) 1.3cm 14. 206cm^3
15. 34.1 litres 16. 140 cm^3