

All questions should be attempted

Marks

1. Find the equation of the perpendicular bisector of the line joining A(2, -1) and B(8, 3). (4)
2. For what value of a does the equation $ax^2 + 20x + 40 = 0$ have equal roots? (2)
3. The diagram shows an incomplete graph of $y = 3 \sin\left(x - \frac{\pi}{3}\right)$, for $0 \leq x \leq 2\pi$. Find the coordinates of the maximum stationary point. (3)

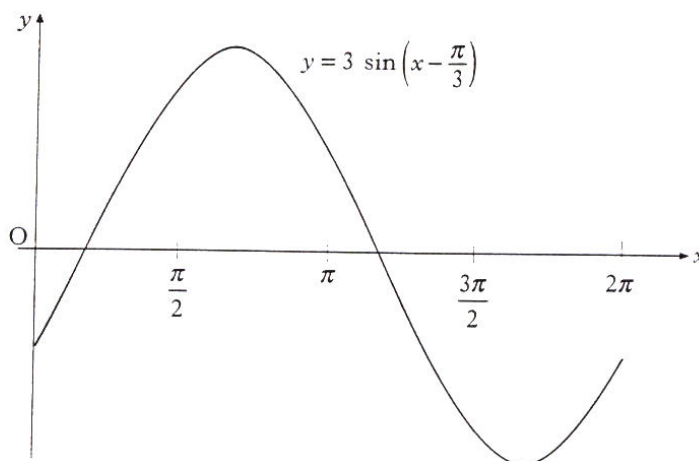

4. Find the equation of the tangent at the point (3, 4) on the circle $x^2 + y^2 + 2x - 4y - 15 = 0$. (4)
5. Evaluate $\int_{-3}^0 (2x+3)^2 dx$. (4)
6. A is the point (2, -5, 6), B is (6, -3, 4) and C is (12, 0, 1). Show that A, B and C are collinear and determine the ratio in which B divides AC. (4)
7. Express $x^4 - x$ in its fully factorised form. (4)

Marks

8. Part of the graph of $y = f(x)$ is shown in the diagram. On separate diagrams, sketch the graphs of

(i) $y = f(x - 1)$

(ii) $y = -f(x) - 2$

indicating on each graph the images of A, B, C and D.

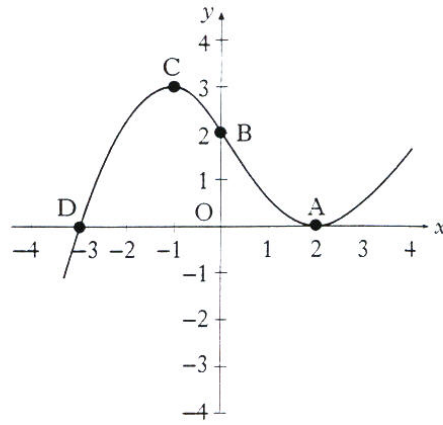

(5)

9. Find $f'(4)$ where $f(x) = \frac{x-1}{\sqrt{x}}$.

(5)

10. Solve algebraically the equation

$$\sin 2x^\circ + \sin x^\circ = 0, \quad 0 \leq x < 360.$$

(5)

11. A sequence is defined by the recurrence relation $u_{n+1} = 0.3u_n + 5$ with first term u_1 .

(a) Explain why this sequence has a limit as n tends to infinity.

(1)

(b) Find the **exact** value of this limit.

(2)

12. The diagram shows a sketch of the graph of $y = \sin\left(2x - \frac{\pi}{6}\right)$, $0 \leq x \leq \pi$, and the straight line $y = 0.5$. These graphs intersect at P and Q.

Find algebraically the coordinates of P and Q.

(4)

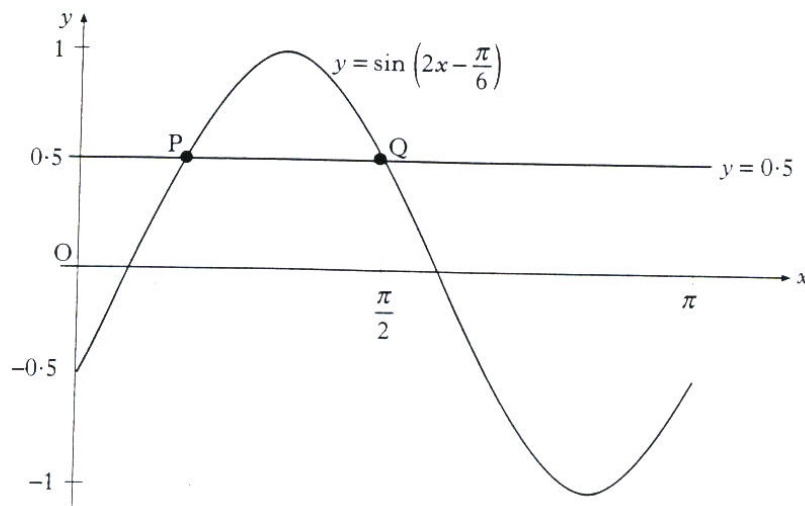

13. Find $\frac{dy}{dx}$, given that $y = \sqrt{1 + \cos x}$.

(3)

Marks

14. Three lines have equations $2x + 3y - 4 = 0$, $3x - y - 17 = 0$ and $x - 3y - 10 = 0$. Determine whether or not these lines are concurrent. (4)

15. The diagram shows two right-angled triangles ABD and BCD with $AB = 7$ cm, $BC = 4$ cm and $CD = 3$ cm. Angle $DBC = x^\circ$ and angle $ABD = y^\circ$. Show that the exact value of

$$\cos(x + y)^\circ \text{ is } \frac{20 - 6\sqrt{6}}{35}.$$

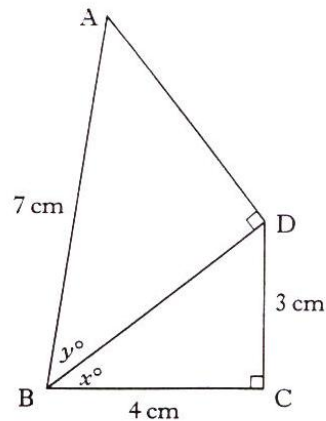

16. Find algebraically the values of x for which the function $f(x) = 2x^3 - 3x^2 - 36x$ is increasing. (4)
17. Express $f(x) = (2x - 1)(2x + 5)$ in the form $a(x + b)^2 + c$. (3)

18. The framework of a child's swing has dimensions as shown in the diagram on the right. Find the exact value of $\sin x^\circ$. (5)

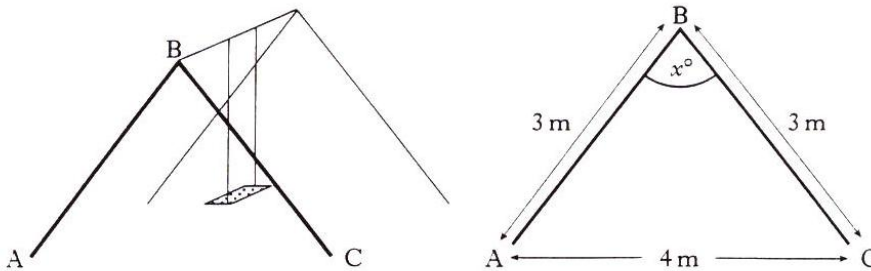

19. A mug of tea cools according to the law $T_t = T_0 e^{-kt}$, where T_0 is the initial temperature and T_t is the temperature after t minutes. All temperatures are in $^\circ\text{C}$.
- (a) A particular mug of tea cooled from boiling point (100°C) to 75°C in a quarter of an hour. Calculate the value of k .
- (b) By how many degrees will the temperature of this tea fall in the next quarter of an hour? (5)

Marks

20. The line $y = -1$ is a tangent to a circle which passes through $(0, 0)$ and $(6, 0)$. Find the equation of this circle. (6)

All questions should be attempted

Marks

1. A curve has equation $y = x^4 - 4x^3 + 3$.

(a) Find algebraically the coordinates of the stationary points. (6)

(b) Determine the nature of the stationary points. (2)

2. A triangle ABC has vertices $A(-3, -3)$, $B(-1, 1)$ and $C(7, -3)$.

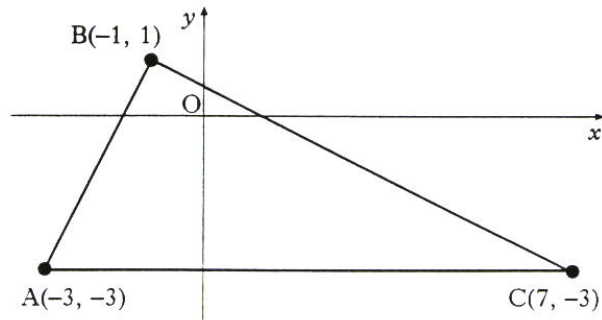

(a) Show that the triangle ABC is right-angled at B. (3)

(b) The medians AD and BE intersect at M.

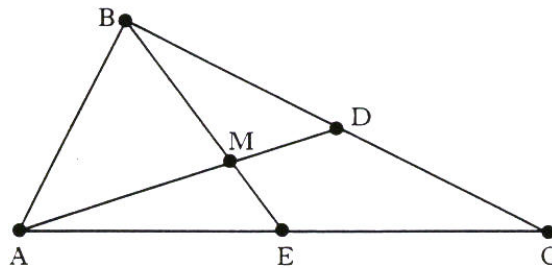

(i) Find the equations of AD and BE. (5)

(ii) Hence find the coordinates of M. (3)

3. The first four levels of a stepped pyramid with a square base are shown in the diagram.

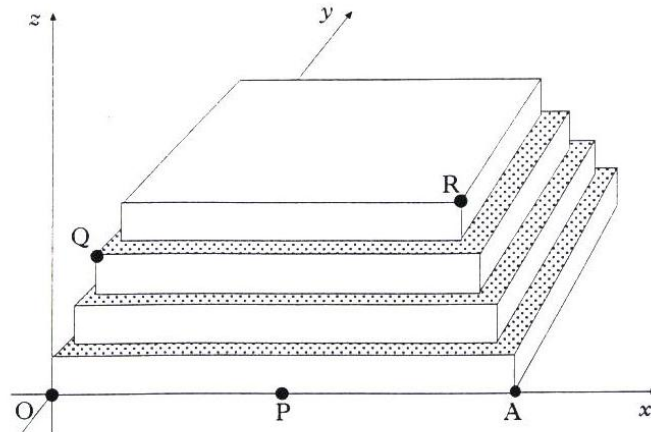

Each level is a square-based cuboid with a height of 3 m. The shaded parts indicate the steps which have a "width" of 1 m.

The height and "width" of a step at a corner are shown in this enlargement.

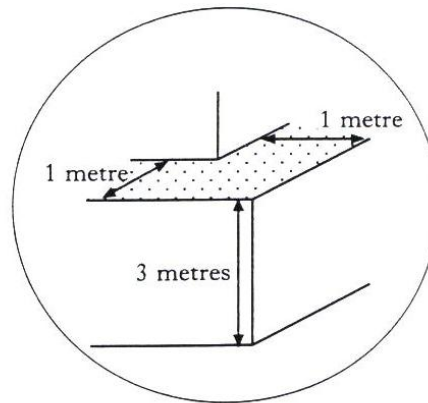

With coordinate axes as shown and 1 unit representing 1 metre, the coordinates of P and A are $(12, 0, 0)$ and $(24, 0, 0)$.

- (a) Find the coordinates of Q and R. (2)
- (b) Find the size of angle QPR. (7)
4. (a) $f(x) = 2x + 1$, $g(x) = x^2 + k$, where k is a constant.
- (i) Find $g(f(x))$. (2)
- (ii) Find $f(g(x))$. (2)
- (b) (i) Show that the equation $g(f(x)) - f(g(x)) = 0$ simplifies to $2x^2 + 4x - k = 0$. (2)
- (ii) Determine the nature of the roots of this equation when $k = 6$. (2)
- (iii) Find the value of k for which $2x^2 + 4x - k = 0$ has equal roots. (3)

5. An artist has designed a “bow” shape which he finds can be modelled by the shaded area below. Calculate the area of this shape. (6)

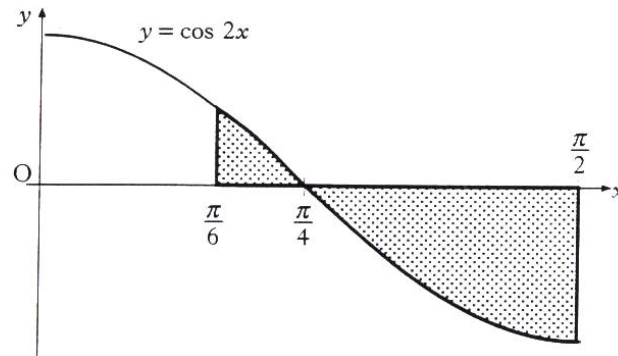

6. Diagram 1 shows:

- the point $A(1, 2)$,
- the straight line l passing through the origin O and the point A ,
- the parabola p with a minimum turning point at O and passing through A ,
- and the circle c , centre O , passing through A .

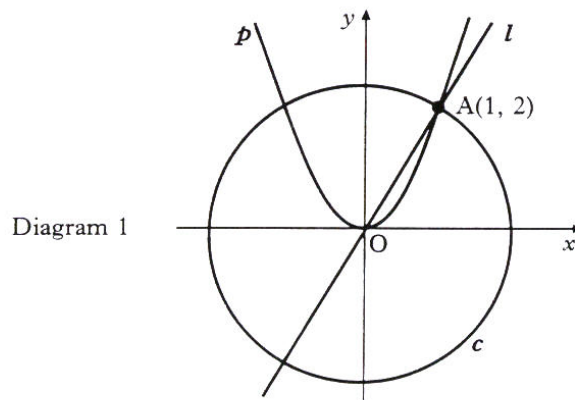

- (a) Write down the equations of the line, the parabola and the circle. (3)

6. (continued)

The following transformations are carried out:

- the line is given a translation of 4 units down (ie -4 units in the direction of the y -axis),
Diagram 2 shows the line l' , the image of line l , after this translation.
- the parabola is reflected in the x -axis,
- the circle is given a translation of 2 units to the right (ie $+2$ units in the direction of the x -axis).

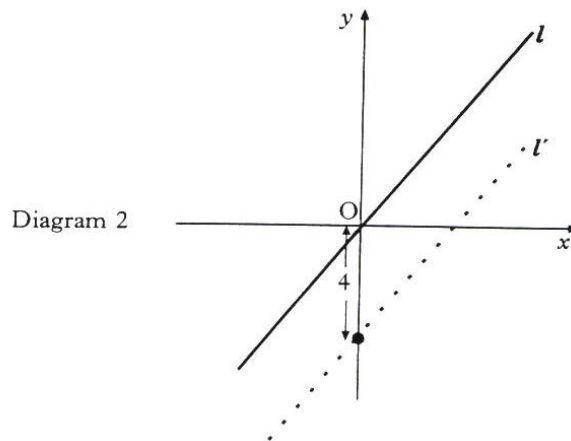

- (b) Write down the equations of l' , p' (the image of the parabola p) and c' (the image of the circle c). (4)
- (c) (i) Show that the line l' passes through the centre of the circle c' . (1)
- (ii) Find the coordinates of the points where the line l' intersects the parabola p' . (3)
7. $f(x) = 2 \cos x^\circ + 3 \sin x^\circ$.
- (a) Express $f(x)$ in the form $k \cos(x - \alpha)^\circ$ where $k > 0$ and $0 \leq \alpha < 360$. (4)
- (b) Hence solve algebraically $f(x) = 0.5$ for $0 \leq x < 360$. (3)

8. In the diagram below, a winding river has been modelled by the curve $y = x^3 - x^2 - 6x - 2$ and a road has been modelled by the straight line AB. The road is a tangent to the river at the point A(1, -8).

Marks

- (a) Find the equation of the tangent at A and hence find the coordinates of B. (8)
- (b) Find the area of the shaded part which represents the land bounded by the river and the road. (3)

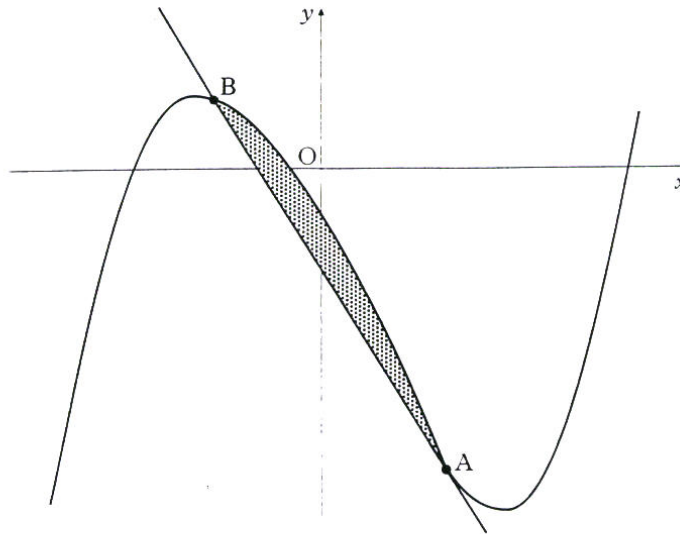

9. Six spherical sponges were dipped in water and weighed to see how much water each could absorb. The diameter (x millimetres) and the gain in weight (y grams) were measured and recorded for each sponge. It is thought that x and y are connected by a relationship of the form $y = ax^b$.

By taking logarithms of the values of x and y , the table below was constructed.

$X (= \log_e x)$	2.10	2.31	2.40	2.65	2.90	3.10
$Y (= \log_e y)$	7.00	7.60	7.92	8.70	9.38	10.00

A graph was drawn and is shown below.

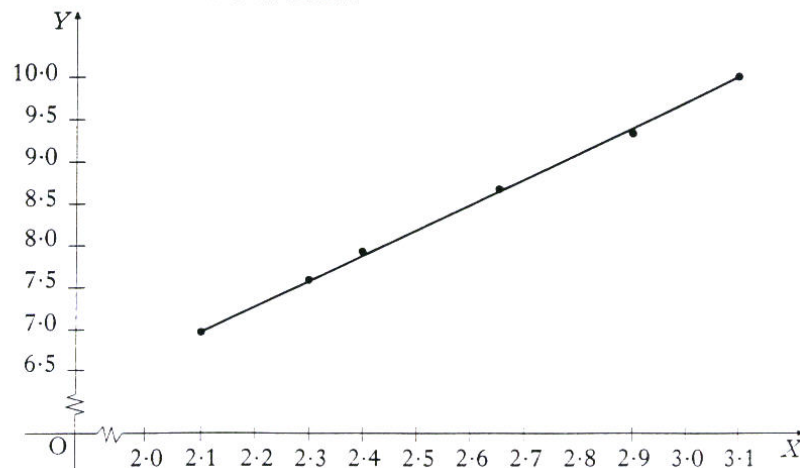

- (a) Find the equation of the line in the form $Y = mX + c$. (3)
- (b) Hence find the values of the constants a and b in the relationship $y = ax^b$. (4)

10. Two curves, $y = f(x)$ and $y = g(x)$, are called orthogonal if, at each point of intersection, their tangents are at right angles to each other.

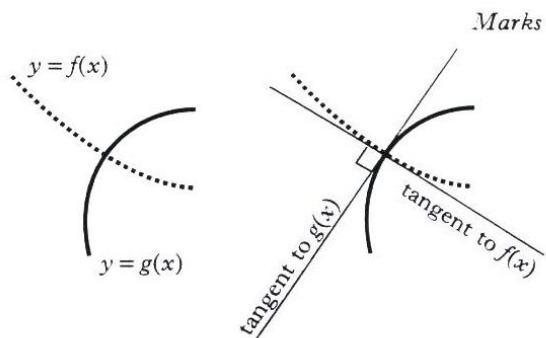

- (a) Diagram 1 shows the parabola with equation $y = 6 + \frac{1}{9}x^2$ and the circle M with equation $x^2 + (y - 5)^2 = 13$.

These two curves intersect at $(3, 7)$ and $(-3, 7)$.

Prove that these curves are orthogonal.

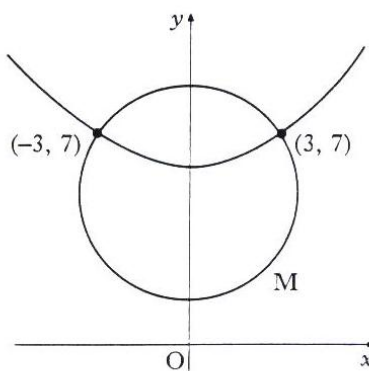

Diagram 1

(6)

- (b) Diagram 2 shows the circle M, from (a) above, which is orthogonal to the circle N. The circles intersect at $(3, 7)$ and $(-3, 7)$.

(i) Write down the equation of the tangent to circle M at the point $(-3, 7)$.

(ii) Hence find the equation of circle N.

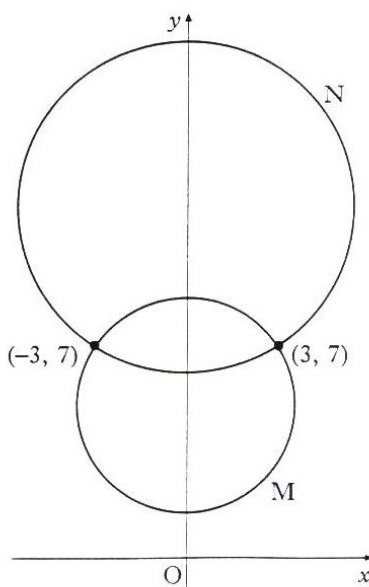

Diagram 2

(1)

(3)

Marks

11. A window in the shape of a rectangle surmounted by a semicircle is being designed to let in the maximum amount of light.

The glass to be used for the semicircular part is stained glass which lets in one unit of light per square metre; the rectangular part uses clear glass which lets in 2 units of light per square metre.

The rectangle measures $2x$ metres by h metres.

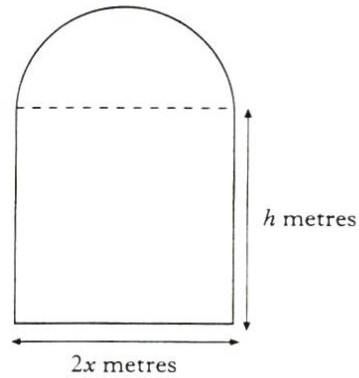
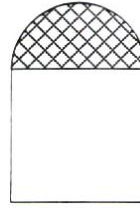

- (a) (i) If the perimeter of the whole window is 10 metres, express h in terms of x . (2)
- (ii) Hence show that the amount of light, L , let in by the window is given by $L = 20x - 4x^2 - \frac{3}{2}\pi x^2$. (2)
- (b) Find the values of x and h that must be used to allow this design to let in the maximum amount of light. (5)

[END OF QUESTION PAPER]