

**2500/405**

---

NATIONAL  
QUALIFICATIONS  
2005

FRIDAY, 6 MAY  
1.30 PM – 2.25 PM

MATHEMATICS  
STANDARD GRADE  
Credit Level  
Paper 1  
(Non-calculator)

- 1 You may **NOT** use a calculator.
- 2 Answer as many questions as you can.
- 3 Full credit will be given only where the solution contains appropriate working.
- 4 Square-ruled paper is provided.

**FORMULAE LIST**

The roots of  $ax^2 + bx + c = 0$  are  $x = \frac{-b \pm \sqrt{(b^2 - 4ac)}}{2a}$

**Sine rule:**  $\frac{a}{\sin A} = \frac{b}{\sin B} = \frac{c}{\sin C}$

**Cosine rule:**  $a^2 = b^2 + c^2 - 2bc \cos A$  or  $\cos A = \frac{b^2 + c^2 - a^2}{2bc}$

**Area of a triangle:** Area =  $\frac{1}{2}ab \sin C$

**Standard deviation:**  $s = \sqrt{\frac{\sum(x - \bar{x})^2}{n-1}} = \sqrt{\frac{\sum x^2 - (\sum x)^2/n}{n-1}}$ , where  $n$  is the sample size.

1. Evaluate

$$3.8 - (7.36 \div 8).$$

2

2. Evaluate

$$2\frac{1}{3} + \frac{5}{6} \text{ of } 1\frac{2}{5}.$$

3

3. Evaluate

$$12.5\% \text{ of } \pounds 140.$$

2

4. Two identical dice are rolled simultaneously.

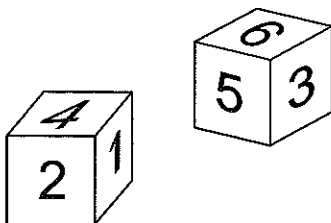

Find the probability that the total score on adding both numbers will be greater than 7 but less than 10.

2

**[Turn over**

KU	RE
3	
3	
3	
	1
	3

5. In an experiment involving two variables, the following values for  $x$  and  $y$  were recorded.

$x$	0	1	2	3	4
$y$	6	4	2	0	-2

The results were plotted, and a straight line was drawn through the points. Find the gradient of the line **and** write down its equation.

6. Solve the equation

$$\frac{2}{x} + 1 = 6.$$

7. The speeds (measured to the nearest 10 kilometres per hour) of 200 vehicles are recorded as shown.

<i>Speed</i> (km/hr)	30	40	50	60	70	80	90	100	110
<i>Frequency</i>	1	4	9	14	38	47	51	32	4

Construct a cumulative frequency table and hence find the median for this data.

8. A number pattern is given below.

1<sup>st</sup> term:  $2^2 - 0^2$

2<sup>nd</sup> term:  $3^2 - 1^2$

3<sup>rd</sup> term:  $4^2 - 2^2$

- (a) Write down a similar expression for the 4<sup>th</sup> term.
- (b) Hence or otherwise find the  $n^{\text{th}}$  term in its simplest form.

9. (a) Emma puts £30 worth of petrol into the empty fuel tank of her car.
- Petrol costs 75 pence per litre.  
Her car uses 5 litres of petrol per hour, when she drives at a particular constant speed.
- At this constant speed, how many litres of petrol will remain in the car after 3 hours?
- (b) The next week, Emma puts £20 worth of petrol into the empty fuel tank of her car.
- Petrol costs  $c$  pence per litre.  
Her car uses  $k$  litres of petrol per hour, when she drives at another constant speed.
- Find a formula for  $R$ , the amount of petrol remaining in the car after  $t$  hours.

10. A badge is made from a circle of radius 5 centimetres.
- Segments are taken off the top and the bottom of the circle as shown.
- The straight edges are parallel.

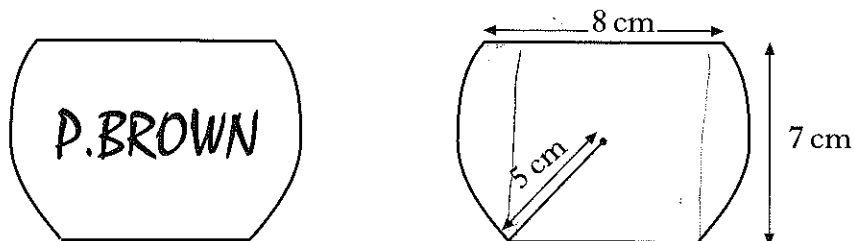

- The badge measures 7 centimetres from the top to the bottom.  
The top is 8 centimetres wide.
- Calculate the width of the base.

[Turn over

KU	RE
2	
	3
	5

KU	RE
----	----

11.  $f(x) = 4\sqrt{x} + \sqrt{2}$

(a) Find the value of  $f(72)$  as a surd in its simplest form.

(b) Find the value of  $t$ , given that  $f(t) = 3\sqrt{2}$ .

3

3

12. The height of a triangle is  $(2x - 5)$  centimetres and the base is  $2x$  centimetres.

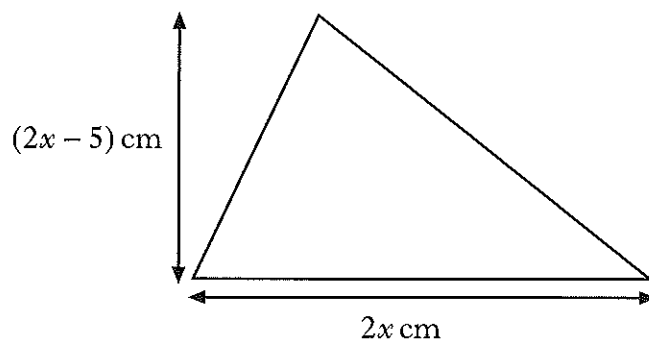

The area of the triangle is 7 square centimetres.

Calculate the value of  $x$ .

5

[END OF QUESTION PAPER]

**2500/406**

---

NATIONAL  
QUALIFICATIONS  
2005

FRIDAY, 6 MAY  
2.45 PM – 4.05 PM

MATHEMATICS  
STANDARD GRADE  
Credit Level  
Paper 2

- 1 You may use a calculator.
- 2 Answer as many questions as you can.
- 3 Full credit will be given only where the solution contains appropriate working.
- 4 Square-ruled paper is provided.

## FORMULAE LIST

The roots of  $ax^2 + bx + c = 0$  are  $x = \frac{-b \pm \sqrt{(b^2 - 4ac)}}{2a}$

**Sine rule:**  $\frac{a}{\sin A} = \frac{b}{\sin B} = \frac{c}{\sin C}$

**Cosine rule:**  $a^2 = b^2 + c^2 - 2bc \cos A$  or  $\cos A = \frac{b^2 + c^2 - a^2}{2bc}$

**Area of a triangle:** Area =  $\frac{1}{2}ab \sin C$

**Standard deviation:**  $s = \sqrt{\frac{\sum(x - \bar{x})^2}{n-1}} = \sqrt{\frac{\sum x^2 - (\sum x)^2/n}{n-1}}$ , where  $n$  is the sample size.



KU	RE
3	
4	
4	
3	

1.  $E = mc^2$ .  
 Find the value of E when  $m = 3.6 \times 10^{-2}$  and  $c = 3 \times 10^8$ .  
 Give your answer **in scientific notation**.

2. The running times in minutes, of 6 television programmes are:

77    91    84    71    79    75.

Calculate the mean and standard deviation of these times.

3.

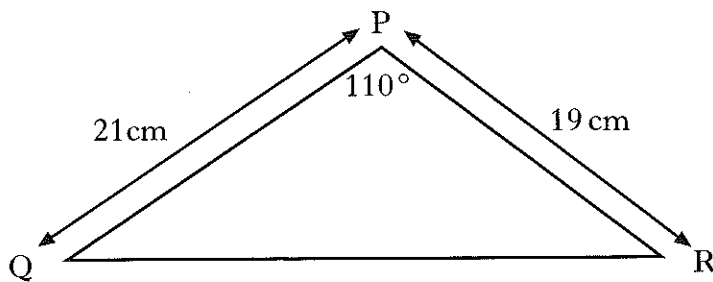

Calculate the area of triangle PQR.

4. Solve the equation

$$x^2 + 2x = 9.$$

Give your answers **correct to 1 decimal place**.

[Turn over

KU	RE
	3
	4

5. A triangular paving slab has measurements as shown.

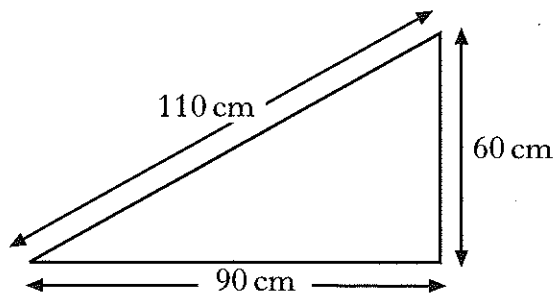

Is the slab in the shape of a right-angled triangle?

**Show your working.**

6. A vertical flagpole 12 metres high stands at the centre of the roof of a tower.  
The tower is cuboid shaped with a square base of side 10 metres.

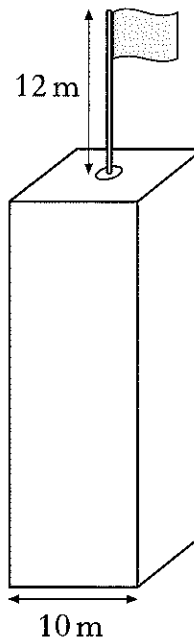

At a point *P* on the ground, 20 metres from the base of the tower, the top of the flagpole is just visible, as shown.

Calculate the height of the tower.

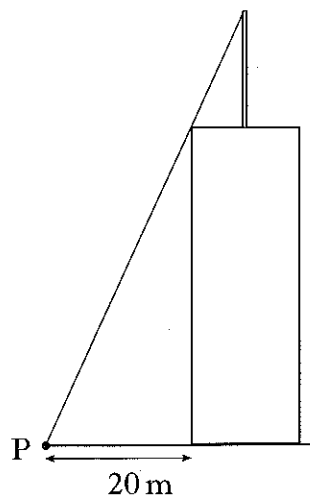

7. David walks on a bearing of  $050^\circ$  from hostel A to a viewpoint V, 5 kilometres away.

Hostel B is due east of hostel A.

Susie walks on a bearing of  $294^\circ$  from hostel B to the same viewpoint.

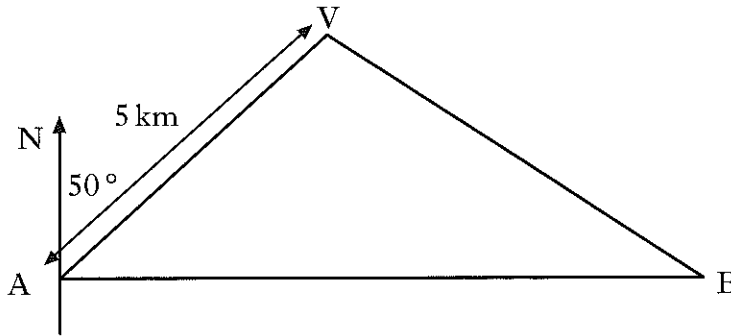

Calculate the length of AB, the distance between the two hostels.

8. The side length of a cube is  $2x$  centimetres.

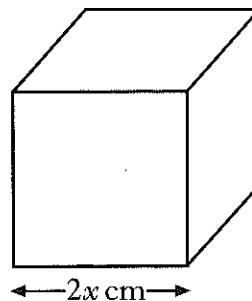

The expression for the volume in cubic centimetres is equal to the expression for the surface area in square centimetres.

Calculate the side length of the cube.

[Turn over

KU	RE
5	5

KU	RE
----	----

9. The monthly bill for a mobile phone is made up of a fixed rental plus call charges. Call charges vary as the time used.

The relationship between the monthly bill,  $y$  (pounds), and the time used,  $x$  (minutes) is represented in the graph below.

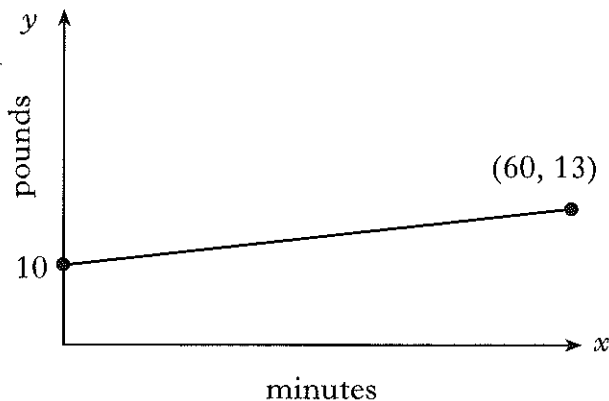

- (a) Write down the fixed rental.  
 (b) Find the call charge per minute.

1

3

10. The chain of a demolition ball is 12.5 metres long.

When vertical, the end of the chain is 1.5 metres from the ground.

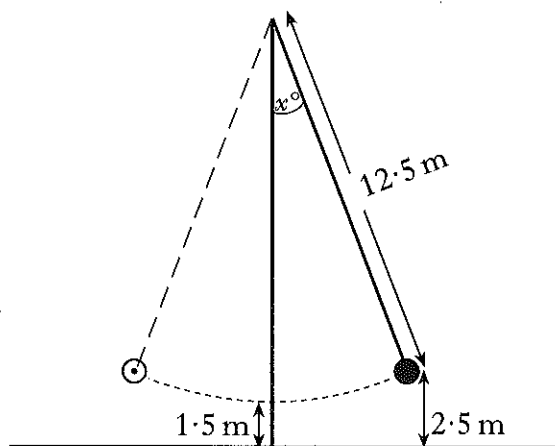

It swings to a maximum height of 2.5 metres above the ground on both sides.

- (a) At this maximum height, show that the angle  $x^\circ$ , which the chain makes with the vertical, is approximately  $23^\circ$ .  
 (b) Calculate the maximum length of the arc through which the end of the chain swings. Give your answer to 3 significant figures.

4

4

11. (a) Solve algebraically the equation

$$\sqrt{3}\sin x^\circ - 1 = 0 \quad 0 \leq x < 360.$$

(b) Hence write down the solution of the equation

$$\sqrt{3}\sin 2x^\circ - 1 = 0 \quad 0 \leq x < 90.$$

[END OF QUESTION PAPER]

KU	RE
3	
	1