

2500/405

NATIONAL QUALIFICATIONS 2004

FRIDAY, 7 MAY
1.30 PM – 2.25 PM

MATHEMATICS
STANDARD GRADE
Credit Level
Paper 1
(Non-calculator)

- 1 You may NOT use a calculator.
- 2 Answer as many questions as you can.
- 3 Full credit will be given only where the solution contains appropriate working.
- 4 Square-ruled paper is provided.

FORMULAE LIST

The roots of $ax^2 + bx + c = 0$ are $x = \frac{-b \pm \sqrt{(b^2 - 4ac)}}{2a}$

Sine rule: $\frac{a}{\sin A} = \frac{b}{\sin B} = \frac{c}{\sin C}$

Cosine rule: $a^2 = b^2 + c^2 - 2bc \cos A$ or $\cos A = \frac{b^2 + c^2 - a^2}{2bc}$

Area of a triangle: Area = $\frac{1}{2}ab \sin C$

Standard deviation: $s = \sqrt{\frac{\sum(x - \bar{x})^2}{n-1}} = \sqrt{\frac{\sum x^2 - (\sum x)^2/n}{n-1}}$, where n is the sample size.

KU	RE
----	----

1. Evaluate

$$6 \cdot 2 - (4 \cdot 53 - 1 \cdot 1).$$

2

2. Evaluate

$$\frac{2}{5} \text{ of } 3\frac{1}{2} + \frac{4}{5}$$

3

3. $A = 2x^2 - y^2$.

Calculate the value of A when $x = 3$ and $y = -4$.

2

4. Simplify

$$\frac{3}{m} + \frac{4}{(m+1)}$$

3

5. The average monthly temperature in a holiday resort was recorded in degrees Celsius ($^{\circ}\text{C}$).

<i>Month</i>	Jan	Feb	Mar	Apr	May	June	July	Aug	Sept	Oct	Nov	Dec
<i>Average Temperature ($^{\circ}\text{C}$)</i>	1	8	8	10	15	22	23	24	20	14	9	4

Draw a suitable statistical diagram to illustrate the median and the quartiles of this data.

4

[Turn over

KU	RE
	2
	2
	3
	2

8. 7, -2, 5, 3, 8

In the sequence above, each term after the first two terms is the sum of the previous two terms.

For example: 3rd term = 5 = 7 + (-2)

(a) A sequence follows the above rule.

The first term is x and the second term is y .

The fifth term is 5.

$x, y, -, -, 5$

Show that $2x + 3y = 5$

(b) Using the same x and y , another sequence follows the above rule.

The first term is y and the second term is x .

The sixth term is 17.

$y, x, -, -, -, 17.$

Write down another equation in x and y .

(c) Find the values of x and y .

9. The graph of $y = a \cos bx^\circ, 0 \leq x \leq 90$, is shown below.

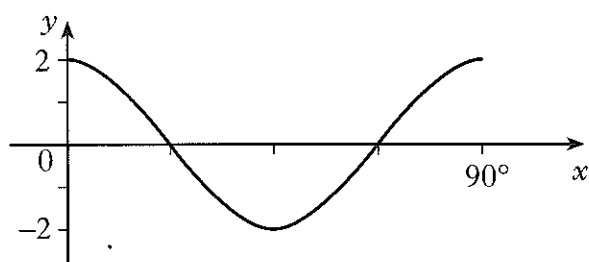

Write down the values of a and b .

[Turn over for Questions 10, 11 and 12 on Page six

10. Two variables x and y are connected by the relationship $y = ax + b$.
 Sketch a possible graph of y against x to illustrate this relationship when a and b are each less than zero.

11. (a) Simplify $2\sqrt{75}$
 (b) Evaluate $2^0 + 3^{-1}$.

12. A piece of gold wire 10 centimetres long is made into a circle.

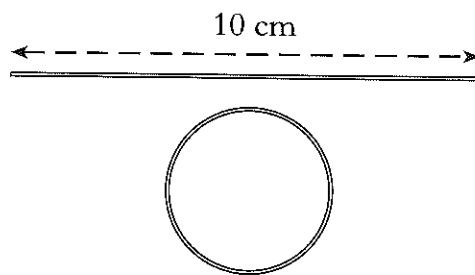

The circumference of the circle is equal to the length of the wire.

Show that the area of the circle is **exactly** $\frac{25}{\pi}$ square centimetres.

[END OF QUESTION PAPER]

KU	RE
	3
2	
2	
	4

2500/406

NATIONAL
QUALIFICATIONS
2004

FRIDAY, 7 MAY
2.45 PM – 4.05 PM

MATHEMATICS
STANDARD GRADE
Credit Level
Paper 2

- 1 You may use a calculator.
- 2 Answer as many questions as you can.
- 3 Full credit will be given only where the solution contains appropriate working.
- 4 Square-ruled paper is provided.

FORMULAE LIST

The roots of $ax^2 + bx + c = 0$ are $x = \frac{-b \pm \sqrt{(b^2 - 4ac)}}{2a}$

Sine rule: $\frac{a}{\sin A} = \frac{b}{\sin B} = \frac{c}{\sin C}$

Cosine rule: $a^2 = b^2 + c^2 - 2bc \cos A$ or $\cos A = \frac{b^2 + c^2 - a^2}{2bc}$

Area of a triangle: Area = $\frac{1}{2}ab \sin C$

Standard deviation: $s = \sqrt{\frac{\sum(x - \bar{x})^2}{n-1}} = \sqrt{\frac{\sum x^2 - (\sum x)^2/n}{n-1}}$, where n is the sample size.

KU	RE
4	
3	3
4	

1. Radio signals travel at a speed of 3×10^8 metres per second.
 A radio signal from Earth to a space probe takes 8 hours.
 What is the distance from Earth to the probe?
 Give your answer **in scientific notation**.

2. A tank which holds 100 litres of water has a leak.
 After 150 minutes, there is no water left in the tank.

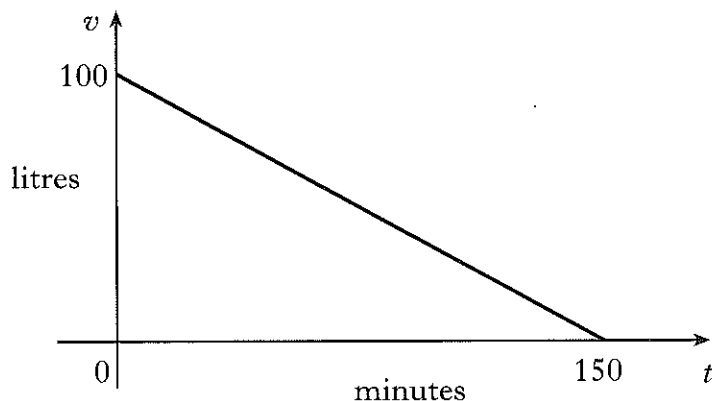

The above graph represents the volume of water (v litres) against time (t minutes).

- (a) Find the equation of the line in terms of v and t .
- (b) How many minutes does it take for the container to lose 30 litres of water?
3. Bottles of juice should contain 50 millilitres.
 The contents of 7 bottles are checked in a random sample.
 The actual volumes in millilitres are as shown below.
- 52, 50, 51, 49, 52, 53, 50
- Calculate the mean and standard deviation of the sample.

4. 250 milligrams of a drug are given to a patient at 12 noon.
 The amount of the drug in the bloodstream decreases by 20% every hour.
 How many milligrams of the drug are in the bloodstream at 3pm?

5. A helicopter, at point H, hovers between two aircraft carriers at points A and B which are 1500 metres apart.

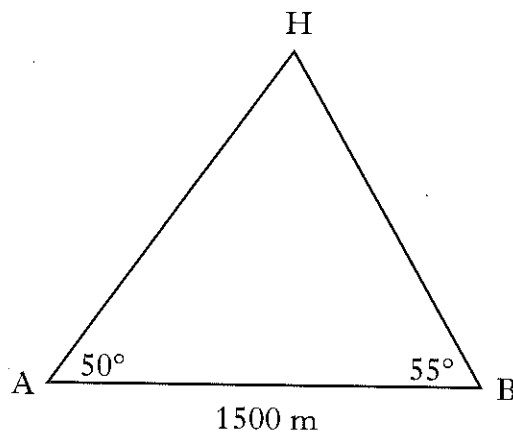

From carrier A, the angle of elevation of the helicopter is 50° .
 From carrier B, the angle of elevation of the helicopter is 55° .
 Calculate the distance from the helicopter to the nearer carrier.

KU	RE
3	
	4

6. The diagram below shows a spotlight at point S, mounted 10 metres directly above a point P at the front edge of a stage.

The spotlight swings 45° from the vertical to illuminate another point Q, also at the front edge of the stage.

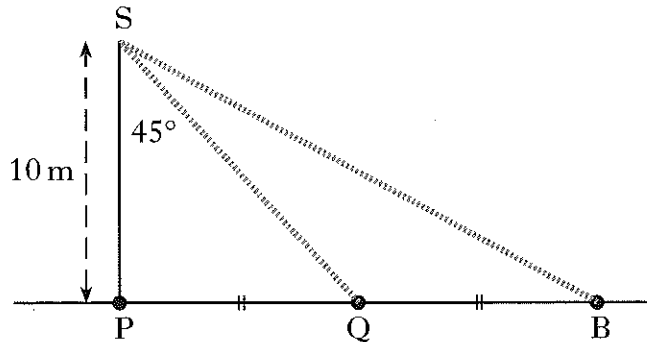

Through how many **more** degrees must the spotlight swing to illuminate a point B, where Q is the mid-point of PB?

5

7. A square trapdoor of side 80 centimetres is held open by a rod as shown.

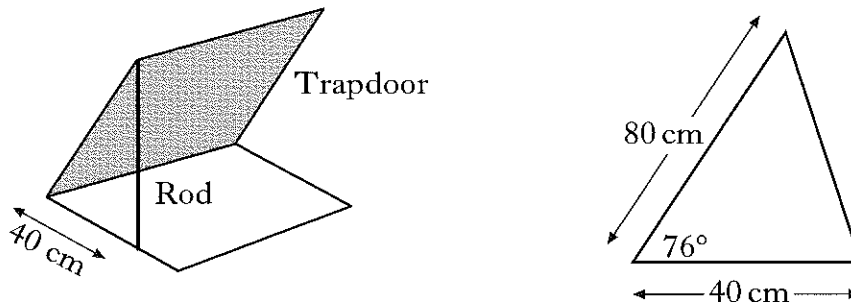

The rod is attached to a corner of the trapdoor and placed 40 centimetres along the edge of the opening.

The angle between the trapdoor and the opening is 76° .

Calculate the length of the rod to **2 significant figures**.

4

[Turn over

8. The curved part of a doorway is an arc of a circle with radius 500 millimetres and centre C.

The height of the doorway to the top of the arc is 2000 millimetres.

The vertical edge of the doorway is 1800 millimetres.

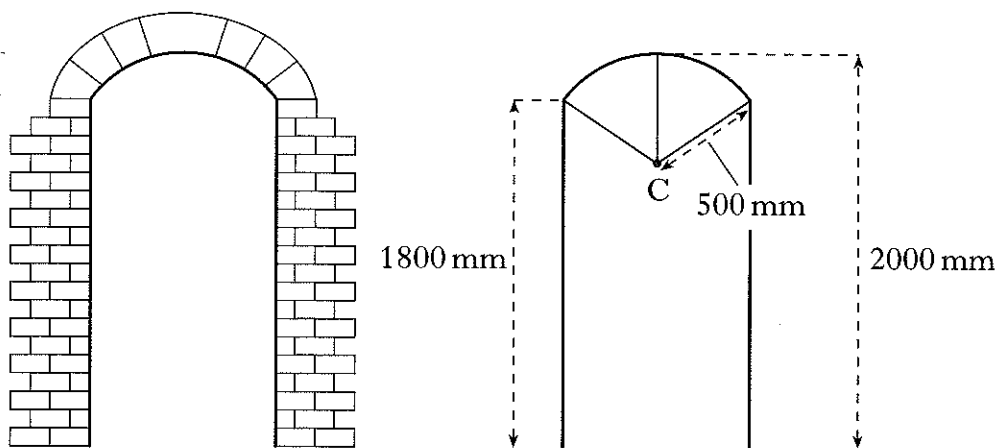

Calculate the width of the doorway.

9. A gift box, 8 centimetres high, is prism shaped.

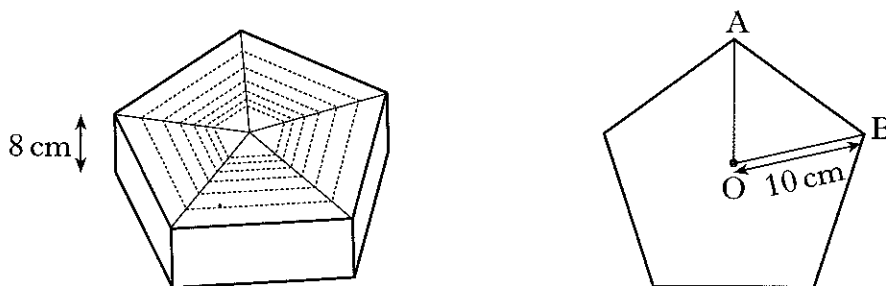

The uniform cross-section is a regular pentagon.

Each vertex of the pentagon is 10 centimetres from the centre O.

Calculate the volume of the box.

KU	RE
	5
	5

KU	RE
3	
	3
	4

10. Solve **algebraically** the equation

$$4 \sin x^\circ + 1 = -2 \quad 0 \leq x < 360.$$

11. A rectangular lawn has a path, 1 metre wide, on 3 sides as shown.

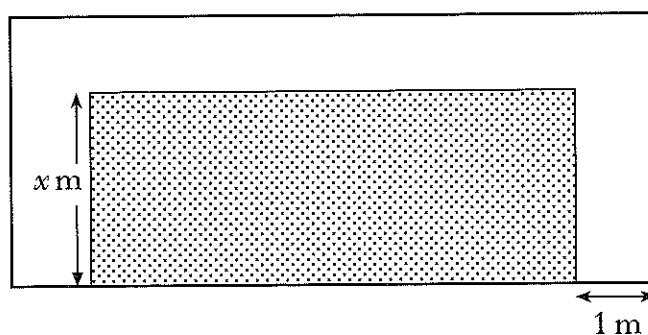

The breadth of the lawn is x metres.

The length of the lawn is three times its breadth.

The area of the lawn equals the area of the path.

(a) Show that $3x^2 - 5x - 2 = 0$.

(b) Hence find the **length** of the lawn.

[END OF QUESTION PAPER]