

ATTEMPT ALL QUESTIONS

DO NOT
WRITE
IN THIS
MARGIN

1. The stools shown below can be assembled to form a cube.

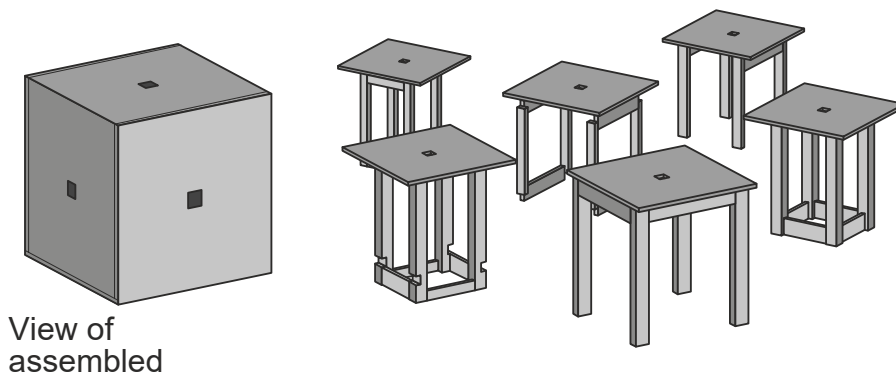

(a) State a **functional** reason for the square hole on the top of each stool.

1

(b) The machine shown below was used during the manufacture of the stools.

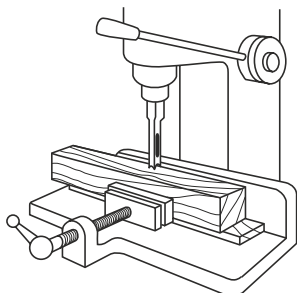

State the name of this machine.

Name of machine _____

1

(c) The plane shown below was used during the manufacture of the stool.

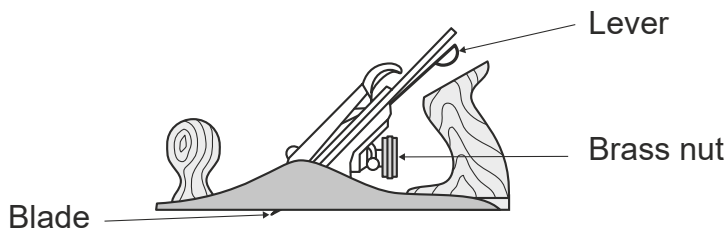

State the effect of the following on the blade.

(i) Turning the brass nut _____

(ii) Adjusting the lever _____

2

1. (continued)

(d) The sash cramp shown below was used during the manufacture of the stools.

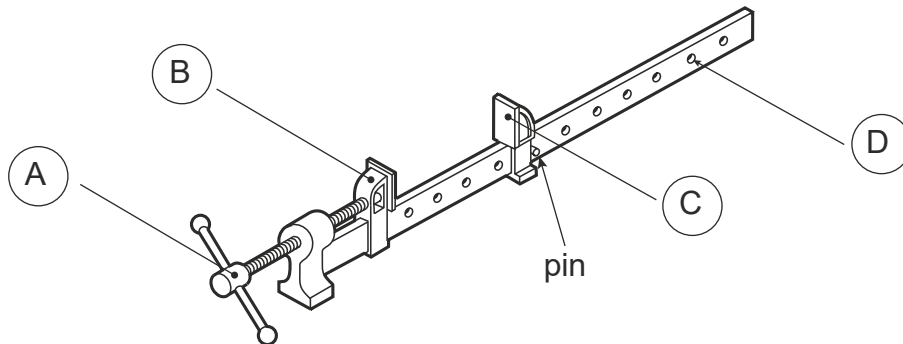

State **two** adjustments that could be made to this tool.

Adjustment 1 _____

Adjustment 2 _____

2

(e) A stool frame is shown below.

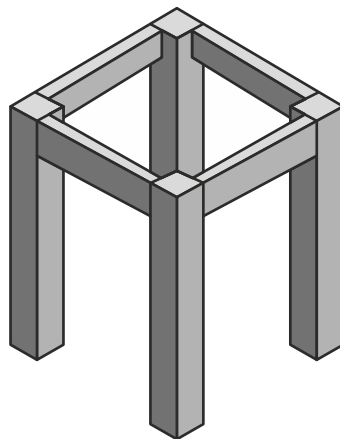

State **two** methods of ensuring the frame is "square"

1. _____

2. _____

2

2. A child's desk made from plywood is shown below.

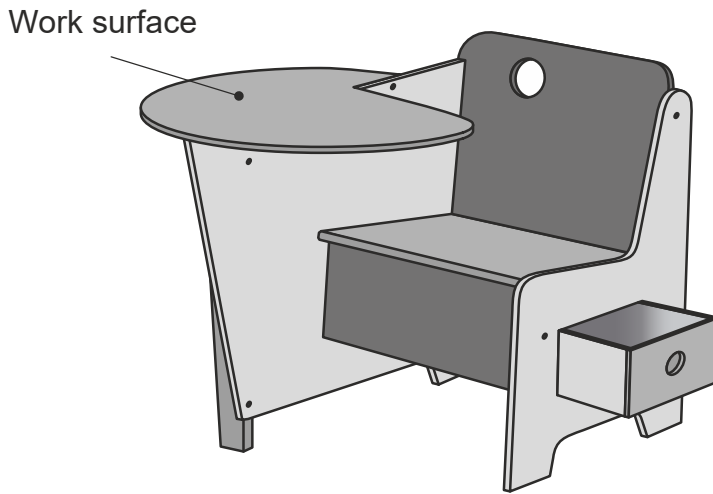

(a) The primary function of the desk is to provide a seat.
State **two** further functions of the desk.

1 _____

2 _____

2

(b) The designer used primary colours to paint the desk.
State **one** reason why primary colours were chosen.

1

(c) A cutting list was produced.

(i) State **two** pieces of information other than sizes that could be found in a cutting list.

1 _____

2 _____

2

2. (c) (continued)

(ii) Plywood is a manufactured board.

Describe how plywood is constructed to give it strength. Sketches may be used.

1

(d) The circular work surface was cut out using a **machine** saw.

State the name of a suitable **machine** saw.

1

(e) Knock down fittings were used in the assembly of the desk.

State **one** advantage of using knock down fittings over traditional joints.

1

(f) Two colours of paint were used in the finishing of the desk.

State a method that would prevent the colours from running together.

1

3. A wooden kitchen utensil is shown below.

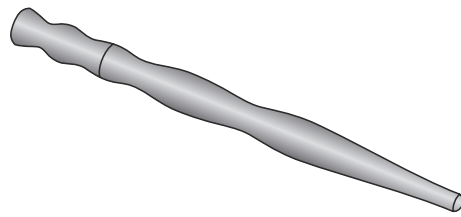

(a) The utensil was manufactured on the machine shown

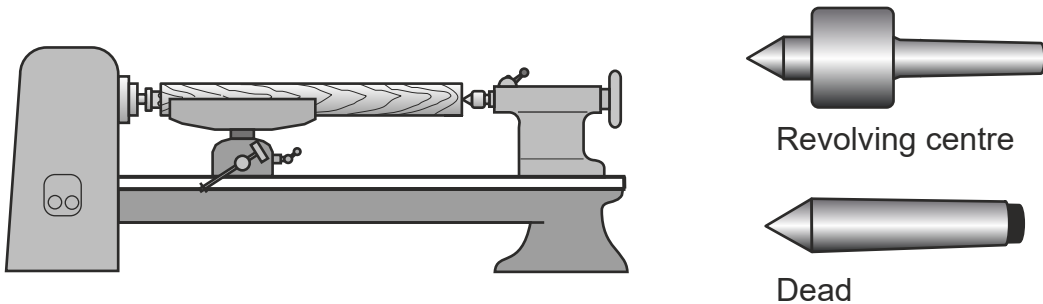

(i) State **one** advantage of using a revolving centre instead of a dead

1

(ii) State the name of the tool used to turn the blank into a cylinder.

1

(iii) State the name of the tool used to check the diameters when

1

(b) The utensil was sanded before removal from the wood lathe.

State **two** adjustments that should be carried out **on the lathe** before sanding.

1 _____

2 _____

2

(c) Vegetable oil was applied as a finish to the utensil.

State a reason why vegetable oil was chosen as the finish.

1

4. A wooden toy is shown below.

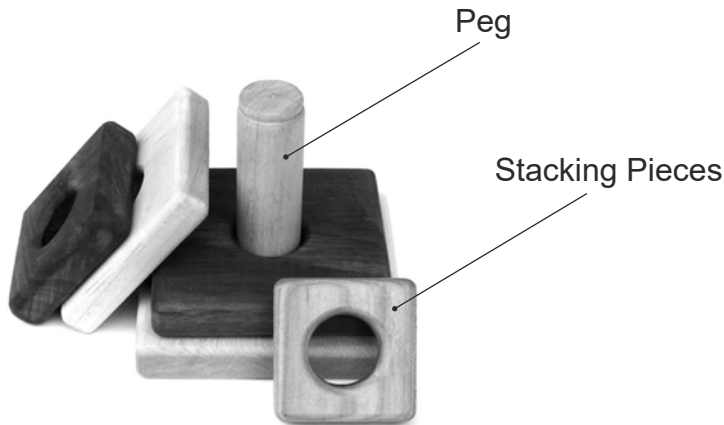

The peg was turned on a wood lathe.

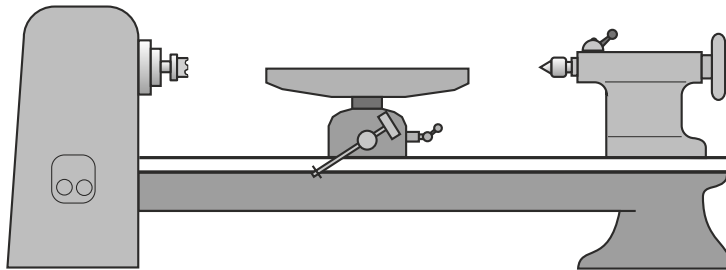

(a) State **two** safety checks made to the **wood lathe** before switching it on.

Safety check 1 _____

Safety check 2 _____

2

(b) The tool shown below was used when manufacturing the peg.

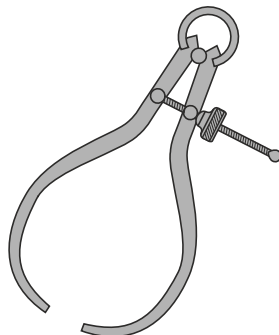

Tool name _____

Tool purpose _____

2

4. (continued)

(c) A hole was drilled in the centre of each stacking piece.

Describe how the centre of the stacking piece can be found, **without measuring**.

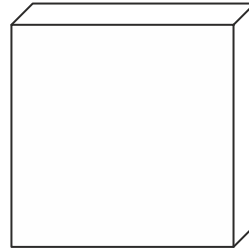

Blank for
stacking

1

(d) The drill bit shown was used in the manufacture of the stacking piece.

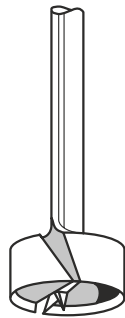

State the name of this drill bit.

1

(e) Glass paper was used to remove pencil marks before applying a finish.

(i) Tick (✓) the box under the sketch which shows the correct direction for glass papering.

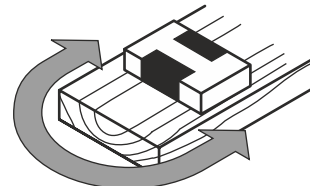
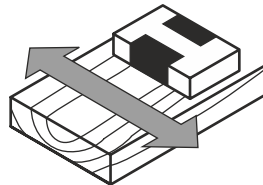
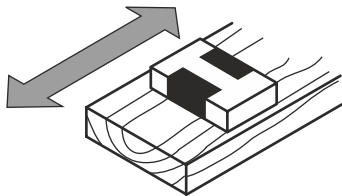

1

(ii) The grain was raised before the finish was applied. Explain **how** this was done.

1

5. A storage rack for garden tools is shown

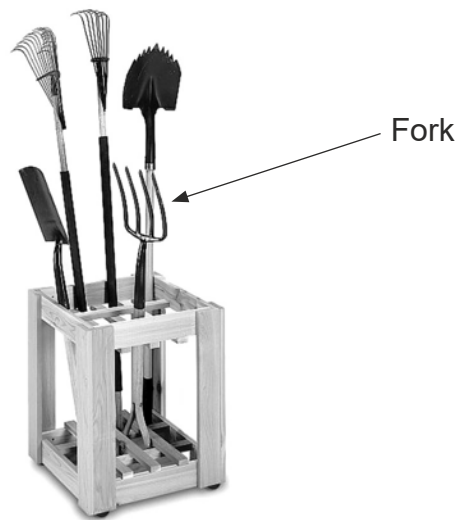

(a) State the fault with this method of storing tools.

1

(b) The following joints were researched during the design of the storage

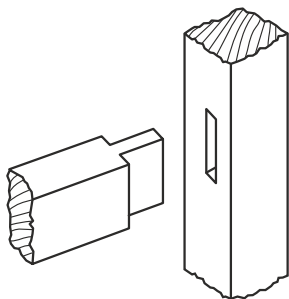

Joint X

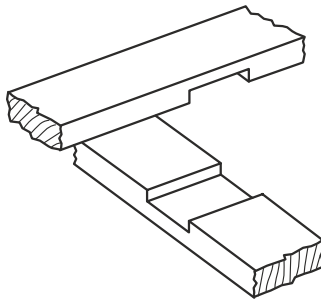

Joint Y

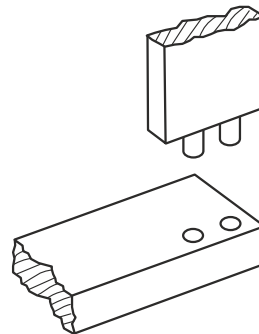

Joint Z

State the name of each joint

Joint X _____

Joint Y _____

Joint Z _____

3

5. (continued)

(c) The tool shown below was used in the manufacture of the storage rack.

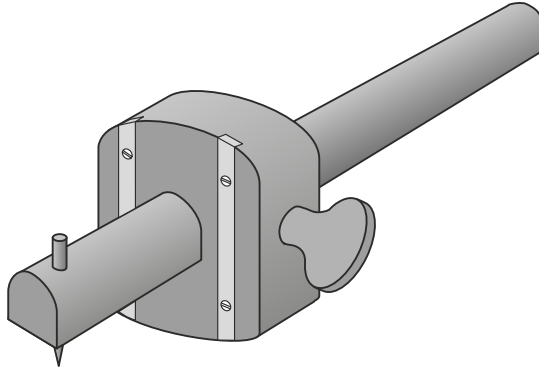

(i) Name of tool

1
0

(ii) Use of tool

1
0

6. A toy train is shown below.

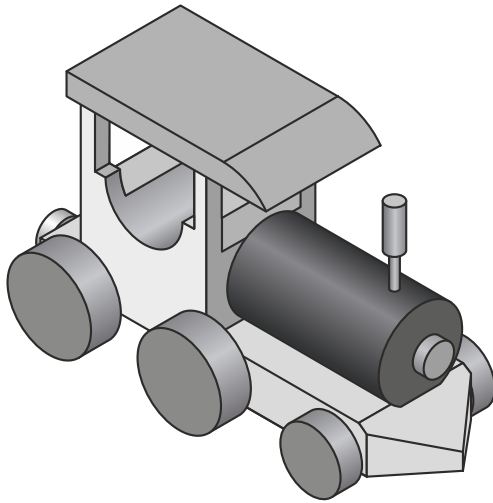

(a) The following factors were considered when designing the toy train.

Manufacture Cost Safety Colour Environment

Select from the list above:

1 the factor which ensures no sharp edges; _____

2 the factor which makes the train look good. _____

2

(b) Part of the train was manufactured using the machine shown below.

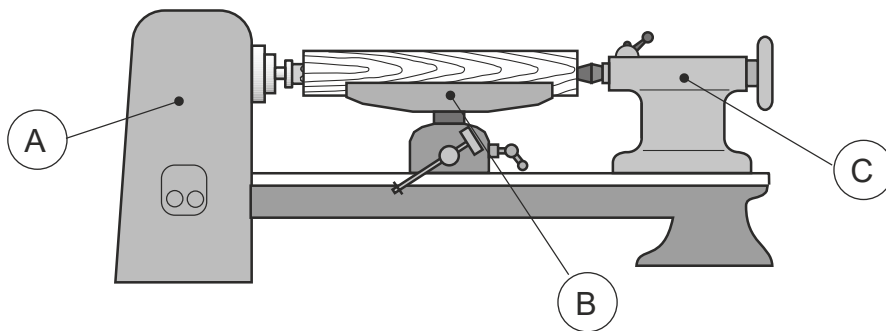

(i) State the name of this machine.

1

(ii) Name the parts shown at A , B and C using the list below.

Tool rest Driving fork Headstock Tailstock Revolving centre

(A) _____

(B) _____

(C) _____

3

6. (continued)

(c) A parting chisel was used during the manufacture of the train.

Tick (✓) the sketch of the parting tool.

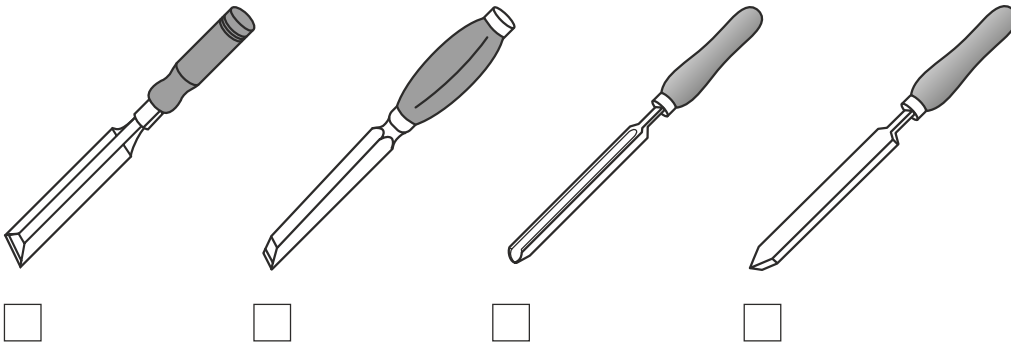

1

(d) The tools shown below were used during the manufacture of the train.

State the name of each tool.

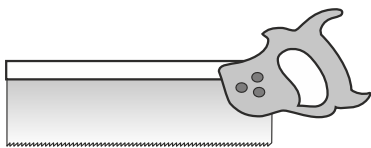

Name _____

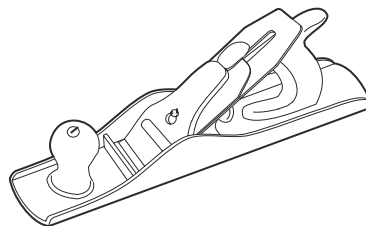

Name _____

2

(e) The machine shown below was used during the manufacture of the toy train.

(i) Tick (✓) the name of the machine.

- Twist drill
- Pedestal drill
- Countersink drill
- Hand drill

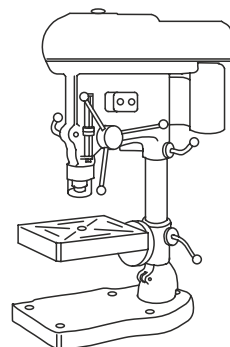

1

(ii) State **two** safety rules which should be followed when using the Machine above.

2

6. (a) (continued)

(iv) The shelving unit was tested.

Tick (✓) the stage in the design process where testing would take

- Developed ideas
- Evaluation
- Analysis

1

(b) The pupil's final design for the shelving unit is shown below.

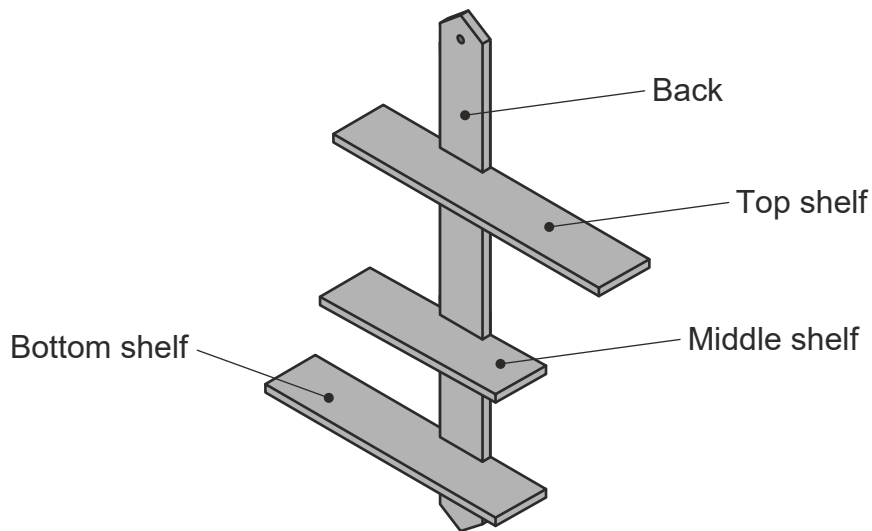

The material for the shelving unit was marked out as shown below.



Complete the cutting list shown below.

Part	Material	Quantity	Length	Width	Thickness
	Manufactured board	1	500	50	10
Top shelf	Manufactured board	1	310	50	10
Middle shelf	Manufactured board	1		50	10
Bottom shelf	Manufactured board	1	250		10

3

6. (continued)

(c) The joint shown below was used in the manufacture of the shelving unit.

Tick (✓) the name of this joint.

- Butt
- Through housing
- Mortise and Tenon
- Stopped Housing

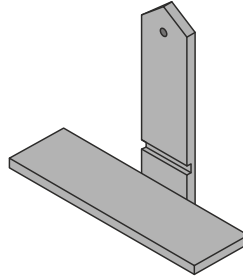

1

(d) The tool shown was used during the manufacture of the shelving unit.

(i) Tick (✓) the name of this tool.

- File
- Chisel
- Marking gauge
- Hand router

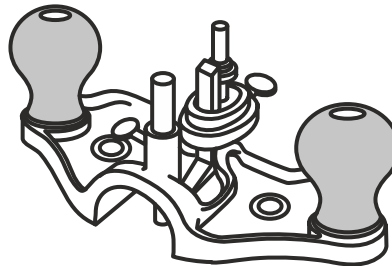

1

(ii) From the list below select the **use** of this tool.

Measuring joint Sanding joint Levelling joint Sawing joint

1

(e) Pencil marks were removed from the shelving unit before applying a finish.

State how the pencil marks could be removed.

1

(f) The screw shown was used to fix the shelving unit to a wall.

Tick (✓) the name of this type of screw.

- Round head
- Raised head
- Countersunk head

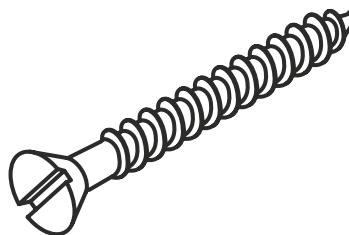

1

7. A children's bathroom step is shown below.

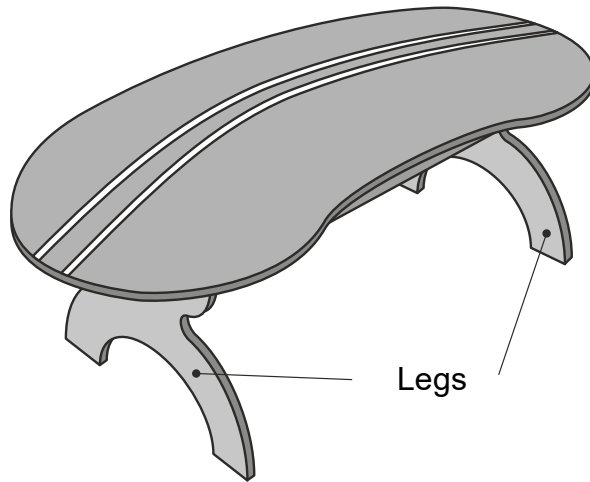

(a) The step was made from a manufactured board.

(i) State the name of a suitable manufactured board.

(ii) State **one** reason for using a manufactured board over a natural wood.

1

(b) A template was used to mark the outline of the legs as shown

1

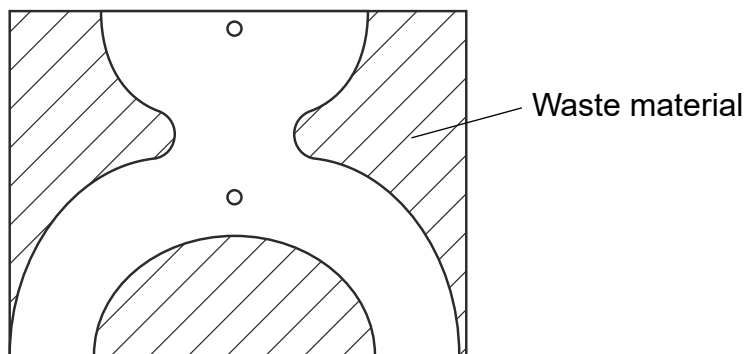

State **two** advantages of using a template.

Advantage 1 _____

Advantage 2 _____

2

7. (continued)

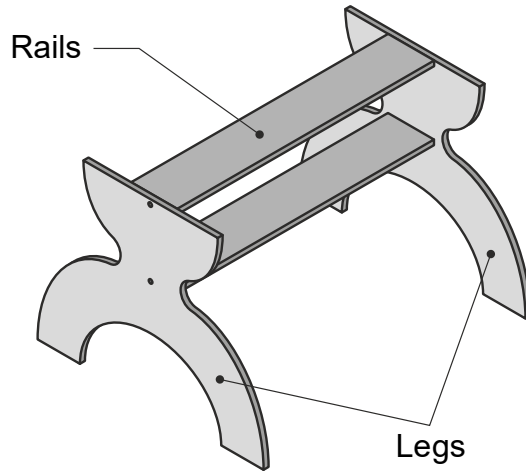

(c) The legs were glued and screwed to the rails during assembly. State one reason why they were screwed together as well as glued.

1

(ii) State the name of this type of wood screw.



1

(iii) State **one** reason for using a wood screw with this type of head.

1

(d) An abrasive paper was used during manufacture. State the name of a suitable type of abrasive paper.

1

(e) Gloss paint was applied as a finish.
State **two** reasons for using a gloss paint finish.

Reason 1 _____

Reason 2 _____

2

8. A table is shown below.



(a) The machine shown below was used in the manufacture of the table. Tick (✓) the name of the machine shown.

- Mortise machine
- Pedestal drill
- Wood lathe
- Sanding

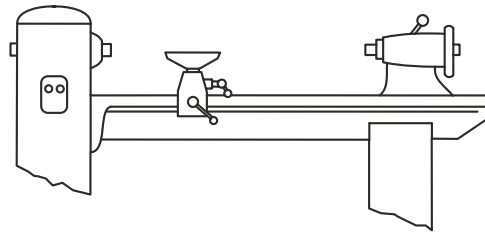

1

(ii) From the list given below, name the parts (A), (B) and (C) of the machine.

Tailstock

Revolving centre

Headstock

Toolrest

Fork centre

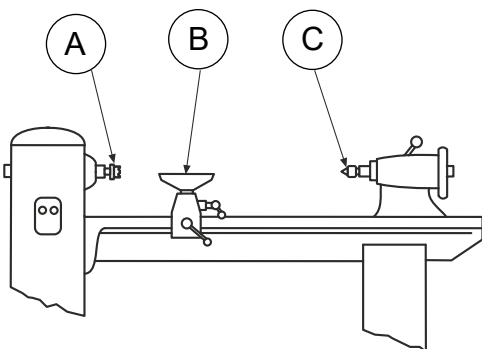

- (A) _____
- (B) _____
- (C) _____

3

(iii) State **two** safety precautions you should follow when using this machine.

2

8. (continued)

(b) The table legs are made from a hardwood. Which of the following is a hardwood?

- Pine
- Plywood
- Beech
- Hardboard

(ii) The corners of the hardwood blank were removed during the preparation process.

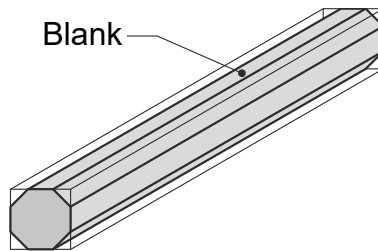

State the name of the tool used to remove the corners.

(iii) The tool shown below was used during the manufacture of the legs. What is this tool used for. Please tick one answer.

- Cutting
- Checking sizes
- Smoothing
- Clamping

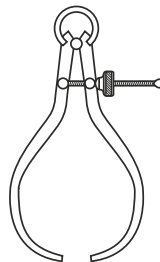

1

1

1

8. (continued)

- (d) (i) The joint shown below was used during the construction of the desk tidy.

Tick (✓) the name of this joint.

- Stopped housing
- Dowel
- Mortise and tenon
- Corner rebate

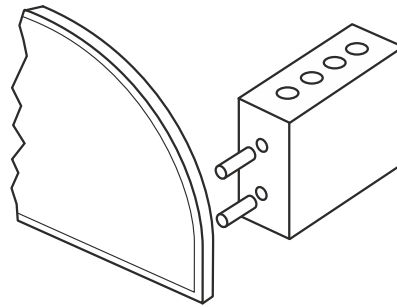

1

- (ii) A white glue was used to glue the joint shown above. Tick (✓) the name of this glue.

- PVC
- TAP
- PVA
- MDF

1

- (iii) The tool shown below was used to hold the joint together while the glue set.

Tick (✓) the correct name for this tool.

- G-clamp
- Bench vice
- Machine vice
- Sash cramp

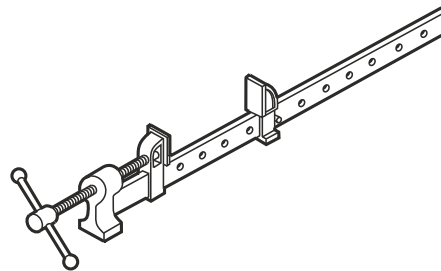

1

9. (a) A wooden chair is shown

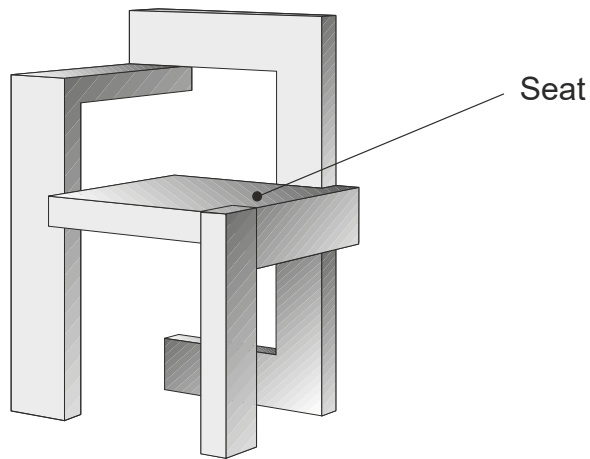

DO NOT
WRITE
IN THIS
MARGIN

(a) A **flat packed** version of the chair was produced.

(i) State an advantage of **flat pack** furniture to:

The retailer

The customer

2

Wooden dowel

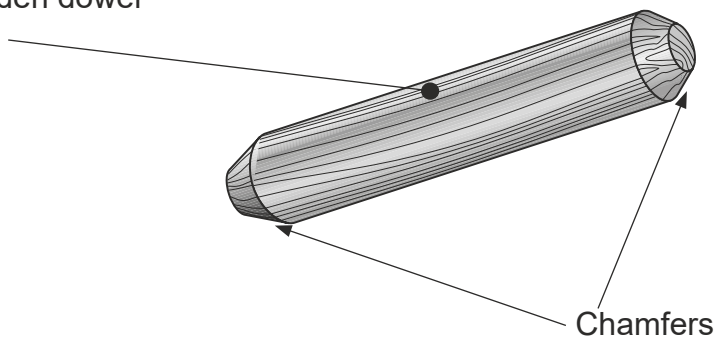

(ii) State the reason for chamfering the ends of the dowel.

1

(iii) The fixings shown are used in the assembly of the chair.

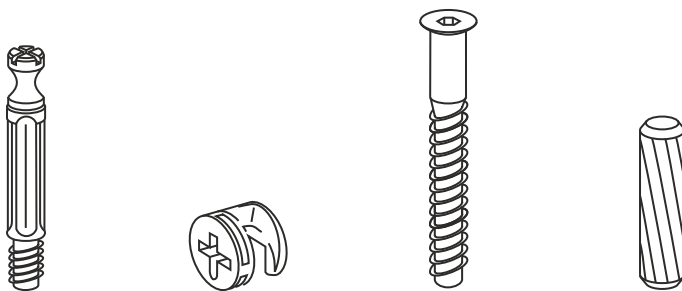

State the collective name of these

1

10. (a) A wooden stool is shown.

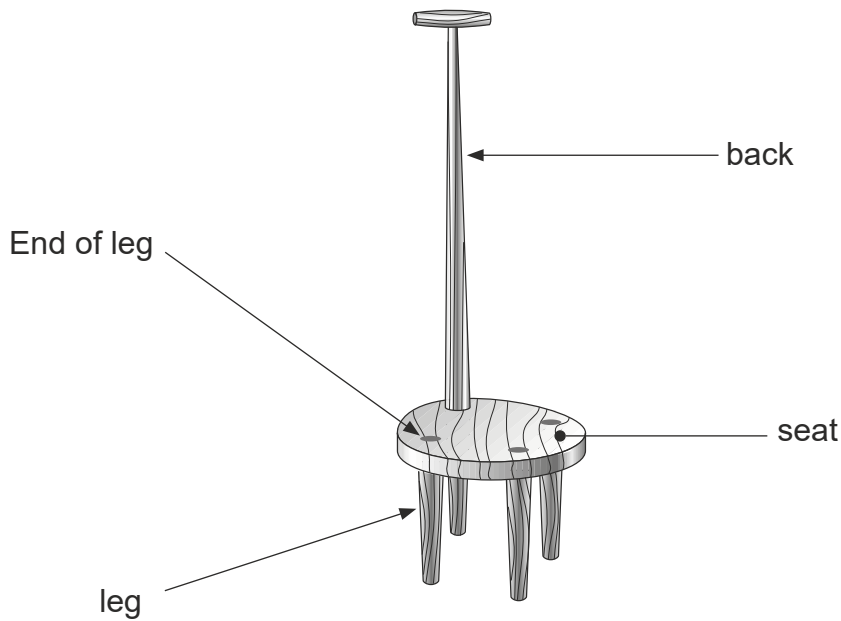

Parts of the stool were manufactured on a wood lathe.

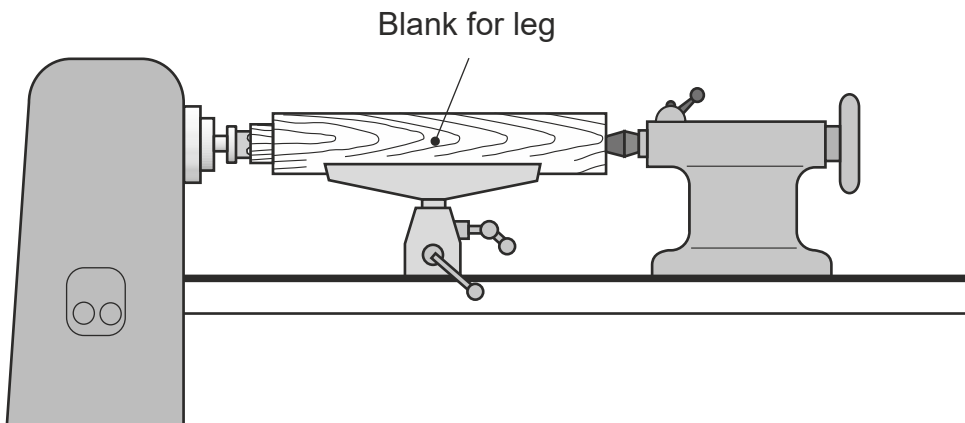

(i) The blank was held between "centres".

State the name of a centre that would be fitted in the:

Headstock _____

Tailstock _____

2

(ii) The "centres" support the blank.

State a further function of the 'centre' fitted in the headstock.

1

(iii) The tailstock can be adjusted.

State why an adjustment of the tailstock may be necessary.

1

10. (continued)

- (b) A gouge and parting chisel were used during the manufacture of the leg shown.

Shoulder



Describe the operation performed by the:

(i) Gouge _____

(ii) Parting chisel _____

2

- (c) State a functional reason for the shoulder at the top of the leg.

1

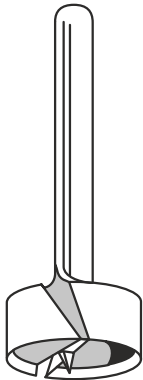

Bit 1



Bit 2

State the name of each bit shown.

Bit 1 _____

Bit 2 _____

2

- (ii) State a reason why bit 1 was preferred when boring the holes in the seat.

1

- (e) A damp cloth was used to wet the stool during the finishing process.

State a reason for wetting the wood.

1

11. A wall mounted storage rack for computer games is shown.

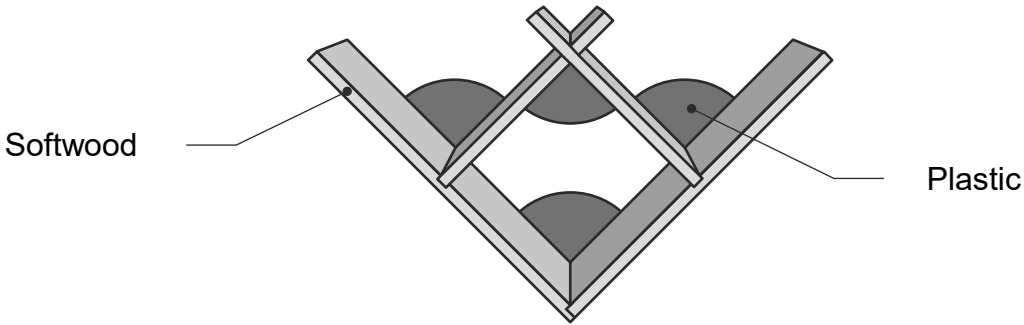

All softwood 12 mm thick

(a) A working drawing and incomplete cutting list for the storage rack is shown below.

Complete the cutting list.

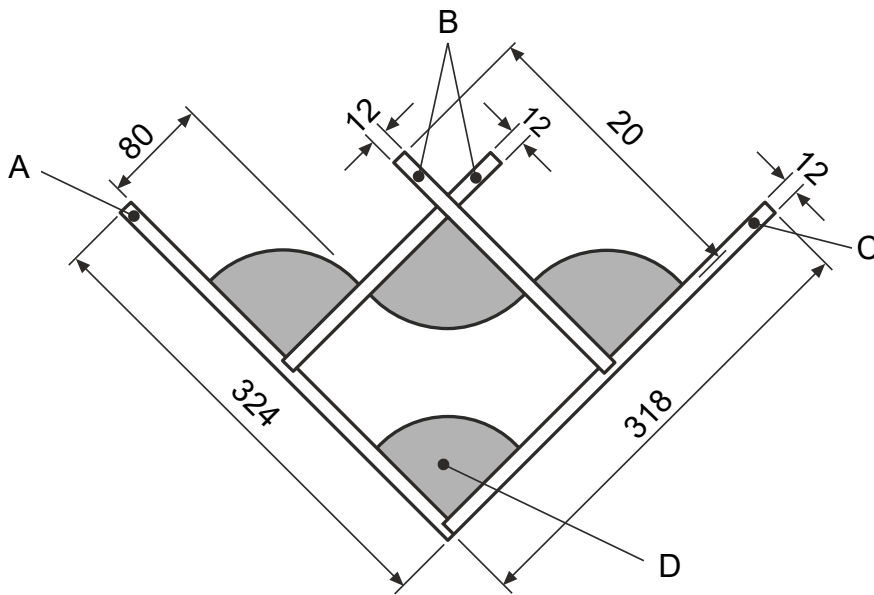

Part	Quantity	Length	Breadth	Thickness	Material
A	1	324	140	12	
B	2	208	140		Softwood
C	1		140	12	Softwood
D	4	80	80	4	Plastic

11. (continued)

(b) (i) A softwood was used in the manufacture of the rack. Which of the following is a softwood?

- Pine
- Oak
- MDF
- Plywood

(ii) The joints shown were used in the manufacture of the storage rack. Select the name of each joint from the list below.

Dowel Mortise and tenon Housing Cross halving Lap

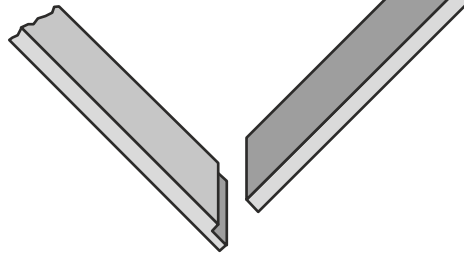
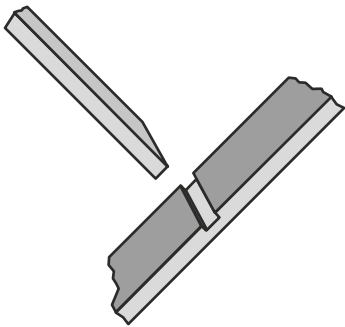

Joint _____

Joint _____

1

2

11. (continued)

- (c) (i) The machine below was used during the manufacture.

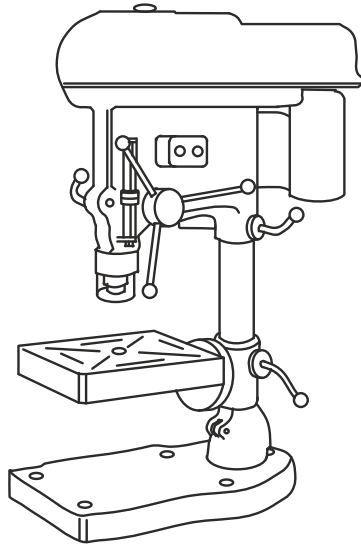

State the name of this machine.

- (ii) From the list below, tick (✓) **three** safety checks that should be carried

- | | |
|--|--|
| <input type="checkbox"/> Material is secured | <input type="checkbox"/> Tool rest is |
| <input type="checkbox"/> Tailstock removed | <input type="checkbox"/> Material turns freely |
| <input type="checkbox"/> Guard is down | <input type="checkbox"/> Chuck key is removed |

- (iii) Wood was placed under the plastic before drilling.

State a reason for this.

- (iv) The covering was kept on the plastic during manufacture.

State a reason for this.

1

3

1

1

[Turn over

12. A bathroom vanity unit is shown below.



(a) The items to be stored in the vanity unit were measured.

Tick (✓) the stage in the design process where this would take place.

- Evaluation
- Presentation drawing
- Research
- Cutting list

1

(b) (i) The joint shown below was used in the manufacture of the vanity unit.

Tick (✓) the name of this joint.

- Rub joint
- Housing joint
- Dowel joint
- Knock down fitting

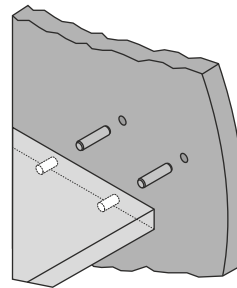

1

(ii) The tool below was used to mark out the joint.

Tick (✓) the name of this tool.

- Steel rule
- Dividers
- Scriber
- Marking gauge

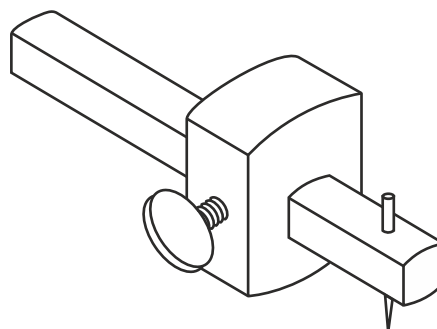

1

12. (continued)

- (c) (i) A white coloured glue was used during the manufacture of the unit.
From the list, select the name of this glue.

PVC Epoxy Impact PVA

Glue _____

1

- (ii) A waterproof glue was used. State a reason for this.

1

- (iii) State a method of removing excess glue from the joints during the manufacture of the vanity unit.

1

- (iv) The tool shown was used to check for squareness. Select the name of the tool from the list below.

- Engineer's square
 Mitre square
 Try square

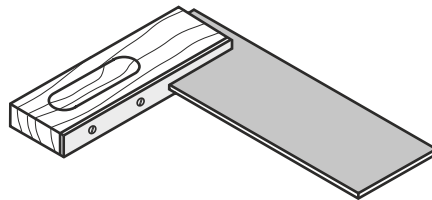

1

- (d) (i) A countersunk screw was used to attach the hinges on the door. Tick the image of a countersunk screw.

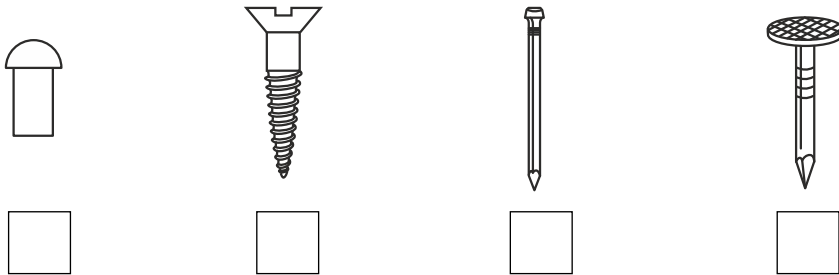

1

- (ii) The tool shown below was used when attaching the hinges. State the name of this tool.

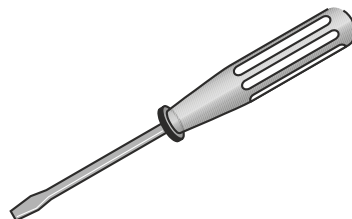

1

13. A table is shown below.

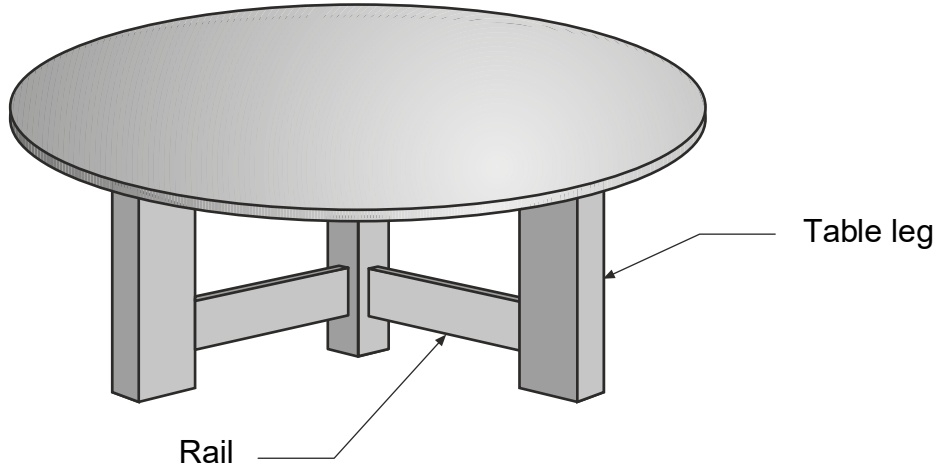

(a) The tool shown below was used in the manufacture of the table



State two separate adjustments that can be made to this tool.

Adjustment one

Adjustment two

13. (continued)

(b) The mortise gauge shown below was used to mark out the mortise and tenon joint.

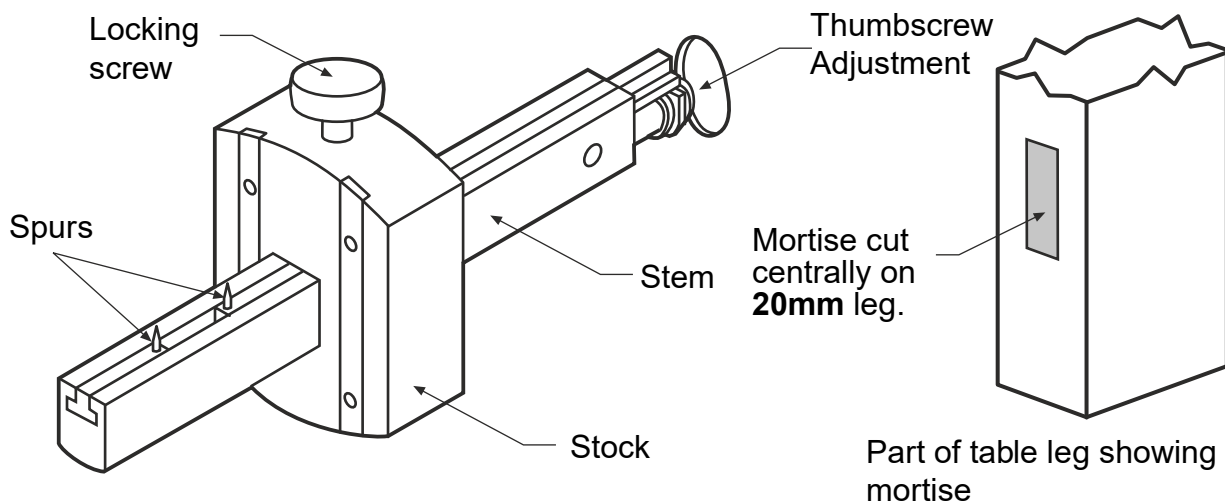

Describe **two steps** to mark a 12mm mortise centrally on the table leg.

Sketches may be used to illustrate your answer. You must reference sizes in your answer.

Step 1

Step 2

(c) The finishing process includes "wetting the wood".

State the purpose of "wetting the wood".

14. A woodpecker toy is shown below.

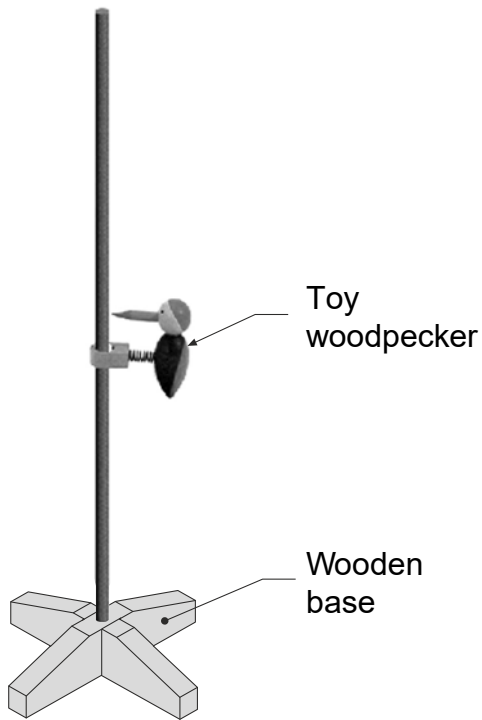

Enlarged view of toy woodpecker

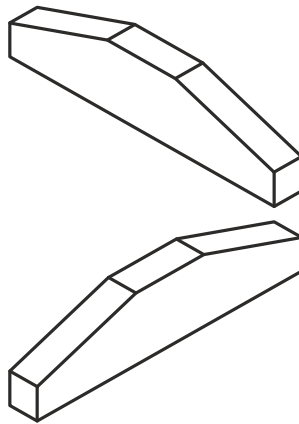

View of parts for base

- (a) The woodpecker is made from a close grained hardwood.
State the name of a suitable hardwood.

1

- (b) The wooden base is made in two parts.
State the name of a **suitable joint** for the base of the woodpecker toy.

1

15. The wooden clothes hanger shown below is designed to hang in a wardrobe or be freestanding.

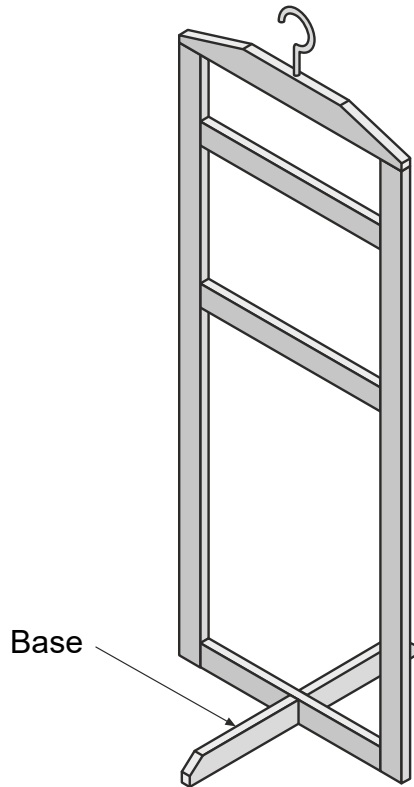

(a) The wood joints shown below were considered during the design of the hanger.
State the name of each joint.

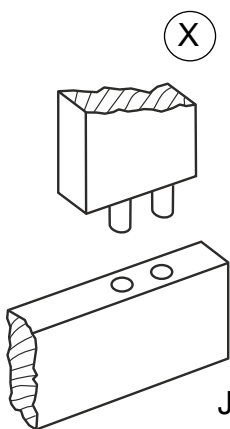

Joint X

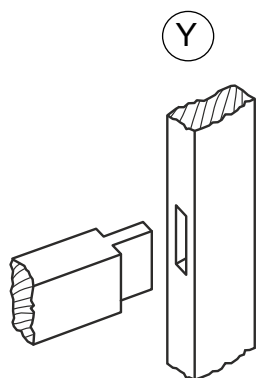

Joint Y

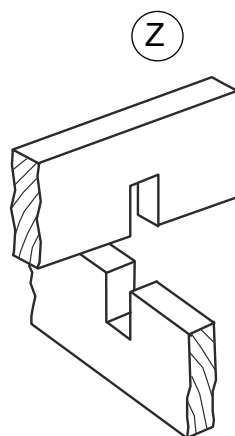

Joint Z

15. (continued)

(b) One half of joint Z is shown below.

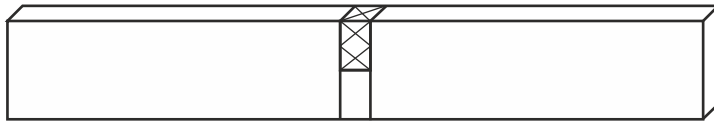

(i) The tools used to mark out the joint are shown below. State the names

Tool (A)

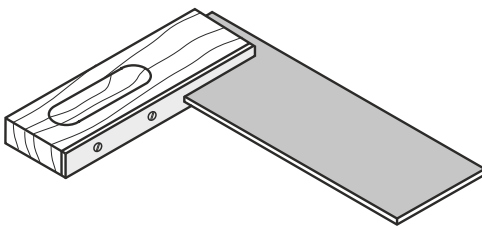

Tool (B)

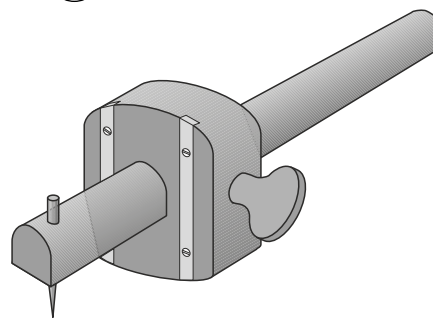

Tool (A) _____ Tool (B) _____

2

(ii) The tools used in the manufacture of the joint are shown below. State the names of these tools.

Tool (C)

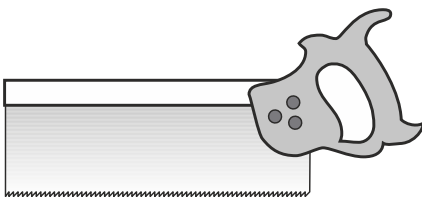

Tool (D)

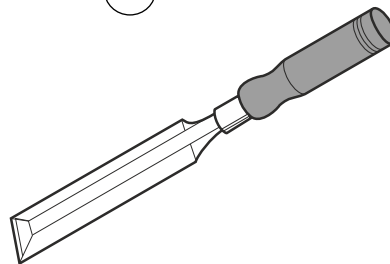

Tool (C) _____ Tool (D) _____

2

(c) Varnish was applied to the hanger. State **two** reasons for applying a varnish finish.

Reason 1

Reason 2

2

16. A wooden kitchen roll holder is shown below.

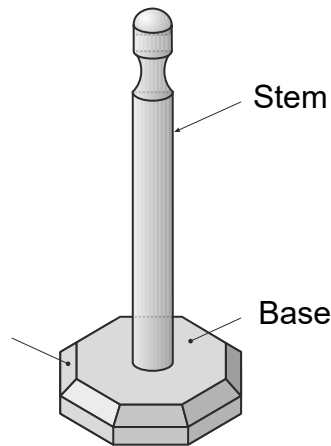

(a) The following statement appeared in the specification. "The holder must be stable."

State which feature of the holder gives it stability.

1

(b) The stem is turned on a wood lathe as shown

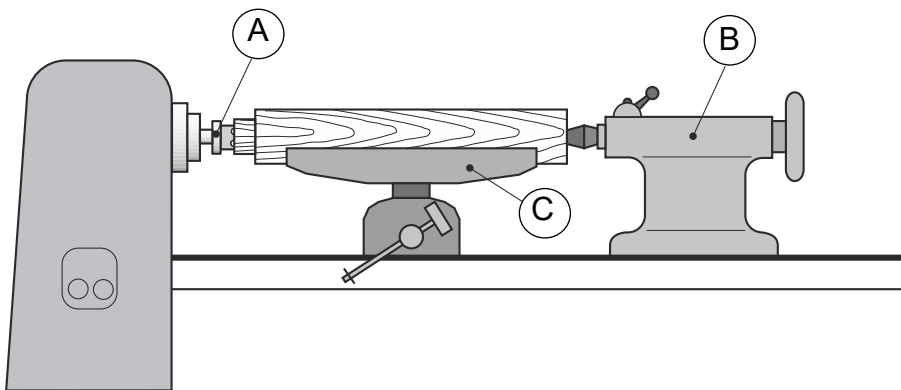

From the list below select the name of parts (A), (B) and (C).

Revolving centre Tailstock Headstock Fork centre Tool rest

(i) Part A

(ii) Part B

(iii) Part C

3

16. (continued)

- (c) State **three** safety checks which should be made to the wood lathe **before switching it on.**

1

2

3

- (e) The wooden base was varnished. State **two** stages in the preparation of The base before applying the varnish.

Stage 1

Stage 2

3

2

17. A school enterprise group made table mats from contrasting strips of wood.

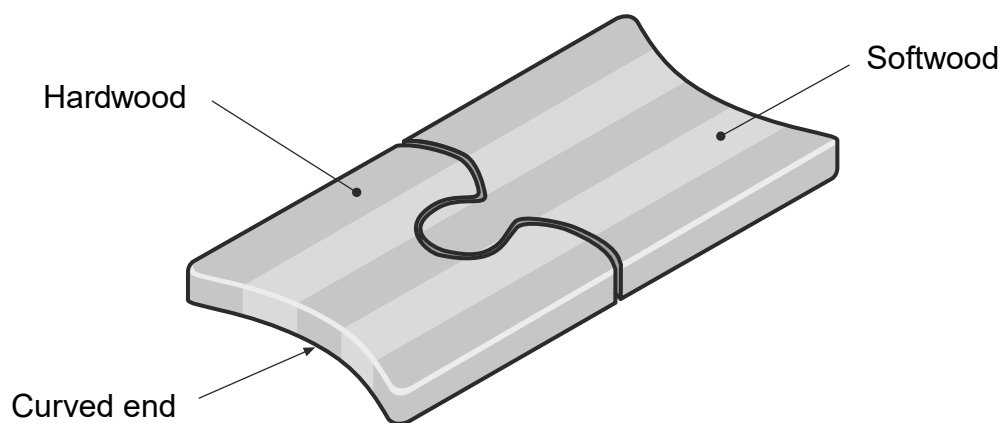

(a) A list of materials is given below.

Hardboard Pine Plywood Beech Blockboard

From the list select:

(i) a hardwood;

(ii) a softwood.

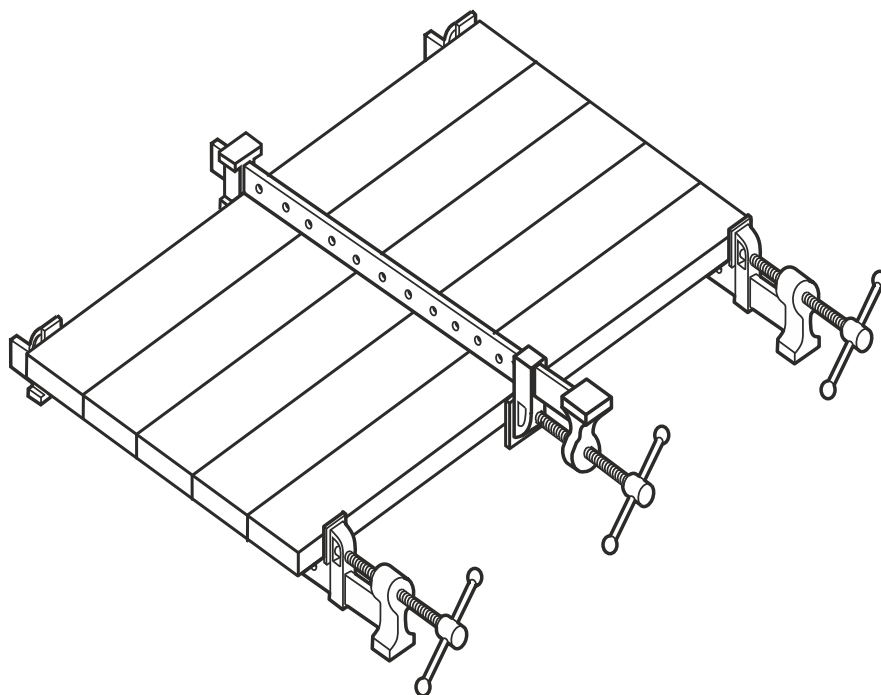

(b) State one reason why the strips of wood have been clamped as shown (i.e. two below and one above).

2

1

17. (b) (continued)

- (ii) The holding device shown below was used to hold the strips while the glue dried.

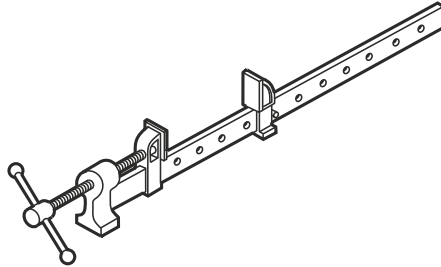

State the name of this device.

1

- (c) A number of mats were produced for sale.

State **two** advantages of using a template to mark out the curved ends.

1.

2.

2

- (d) State the name of a **machine** tool and a **hand** tool suitable for cutting out the curved ends.

- (i) Machine tool

Hand tool

2

18. A wooden base for a table lamp is shown below.

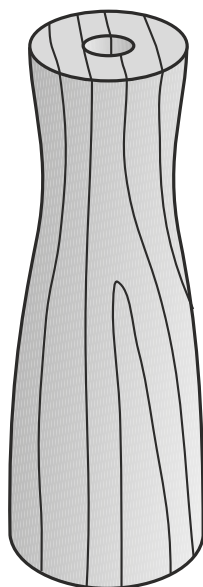

(a) (i) The base was manufactured on the machine shown below.

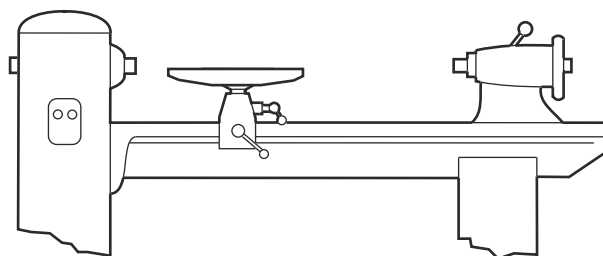

State the name of this machine.

1

(ii) Tick (✓) the name of the process carried out by this machine.

Forging

Casting

Turning

3

18. (continued)

(b) A list of tools used to prepare the wooden blank is given below. From this list write the name of the tool used at each stage.

Tenon Saw Marking Gauge Smoothing Plane Rule and Pencil

Stage 1 – Mark diagonals

Stage 2 – Score line parallel to edges

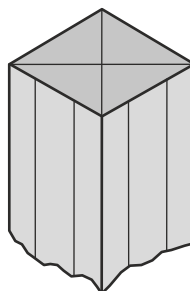
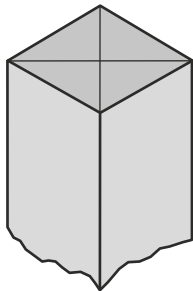

Tool _____

Tool _____

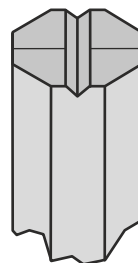
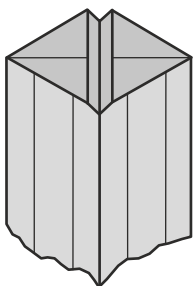

Tool _____

Tool _____

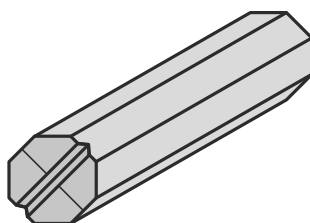

Finished Blank

19. A decorative wooden box and stand are shown.

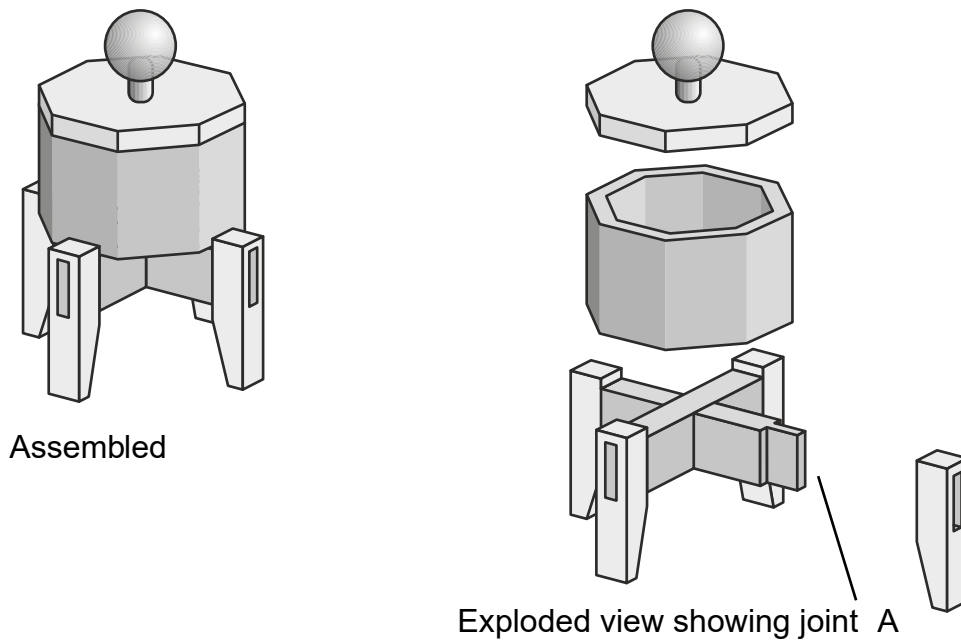

(a) State the name of joint A .

1

The tool shown below was used to mark out the joint.

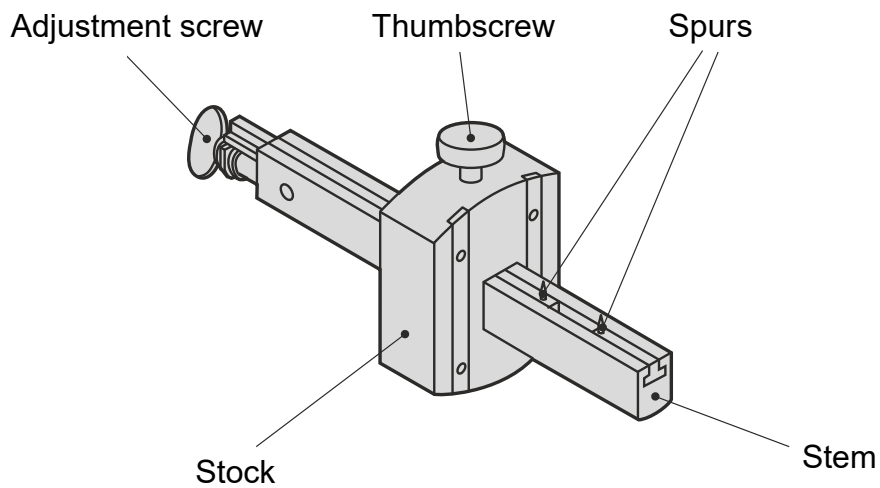

(b) (i) State the name of this tool.

1

(ii) State two adjustments that can be made to this tool.

Adjustment 1 _____

Adjustment 2 _____

2

19. (continued)

- (c) State the name of another joint that could have been used as an alternative to joint A.

1

- (d) Joint A was “dry clamped”.
State the purpose of dry clamping.

1

- (e) The tool below was used in the manufacture of the box.

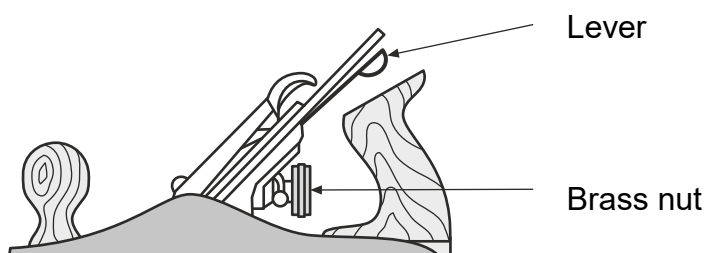

- (i) State the purpose of the lever.

- (ii) State the purpose of the brass nut.

2

20. A storage rack for computer games made from hardwood is shown.

Decorative holes

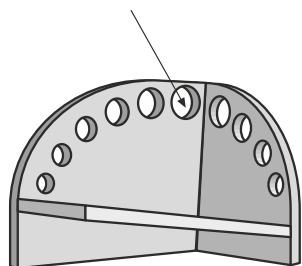

Empty Rack

Curved edge "C"

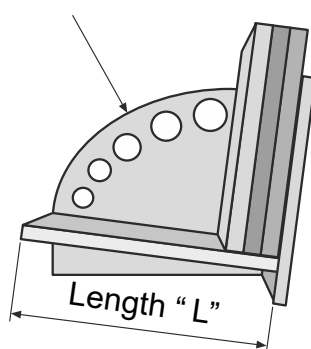

Rack with some games
in place

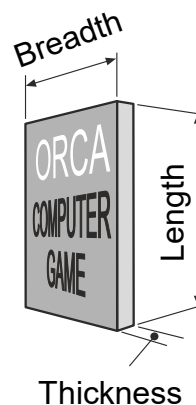

Computer game

(a) From the list below, **select** a suitable **hardwood**.

Pine

Beech

Spruce

MDF

1

(b) Tick (✓) **two** pieces of information that will determine the **length "L"** of the storage rack.

- | | |
|---|---|
| <input type="checkbox"/> The length of computer game | <input type="checkbox"/> The breadth of computer game |
| <input type="checkbox"/> The type of computer game | <input type="checkbox"/> The number of computer games |
| <input type="checkbox"/> The thickness of computer game | <input type="checkbox"/> The cost of computer game |

2

(c) The joint shown was used in the manufacture. Tick (✓) the name of the

- Cross halving
- Through housing
- Mortise and tenon
- Stopped housing

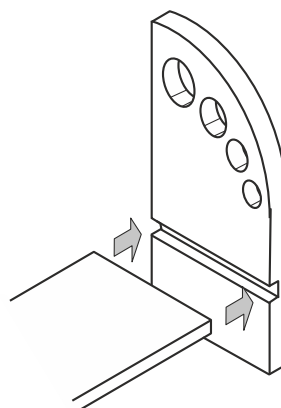

1

20. (continued)

(d) The tools used to **mark out** and **cut** the joint are shown below.

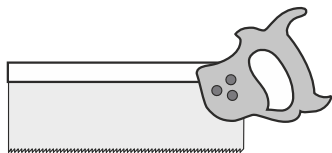

Tenon saw

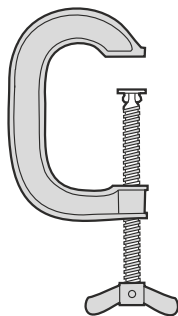

G-clamp

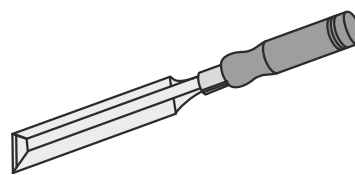

Bevel-edged

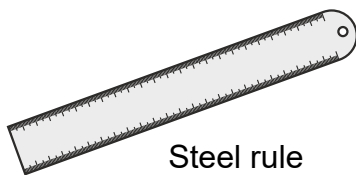

Steel rule

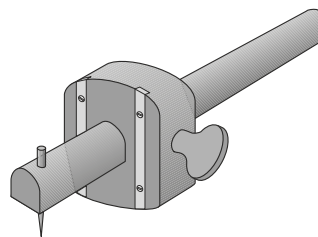

Marking gauge

State the name of the tool used for each of the stages listed below.

- Measuring

- Marking the depth of the joint

- Holding the material while cutting

(e) State the name of a machine tool that can be used to shape the curved edge “C” of the storage rack.

Name of machine tool _____

3

1

20. (continued)

(f) The tool shown below was used during the manufacture of the storage rack.
Tick (✓) the name of this tool.

- Flat bit
- Countersink bit
- Auger bit
- Forstner bit

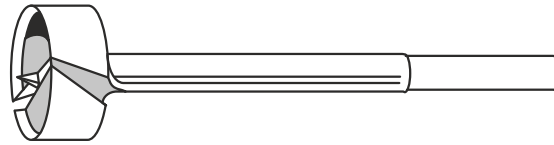

1

(g) The storage rack is to be finished using **varnish**.
State a method of **applying** the varnish **thinly** and **evenly**.

1

21. A storage rack for use in a kitchen is shown.

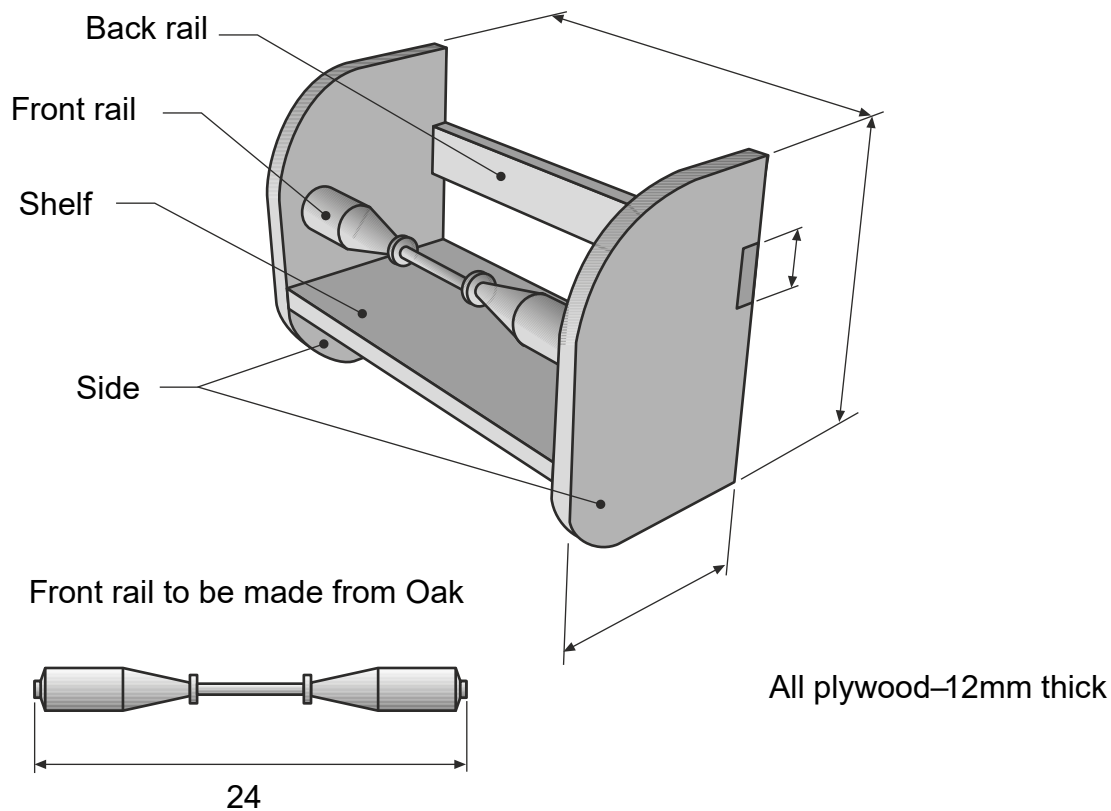

(a) Using the information above, **complete** the cutting list shown below.

Part name	Material	Quantity	Length	Breadth	Thickness
Front rail	_____	1	240	30	30
Back rail	Plywood	1	_____	40	12
Shelf	Plywood	1	240	120	_____
Side	Plywood	_____	180	_____	12

21. (continued)

(b) The shape "X" shown below made from card was used to mark out the Sides of the rack **quickly** and **accurately**.

State the name of this type of marking out aid.

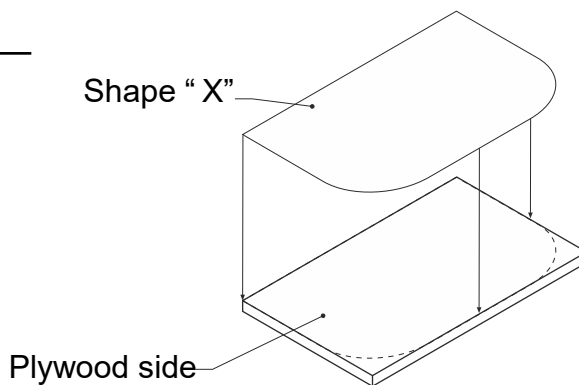

1

(c) The tool shown below was used in the manufacture of the storage rack.

Tick (✓) the name of this tool.

- Hand router
- Roughing tool
- Jack Plane

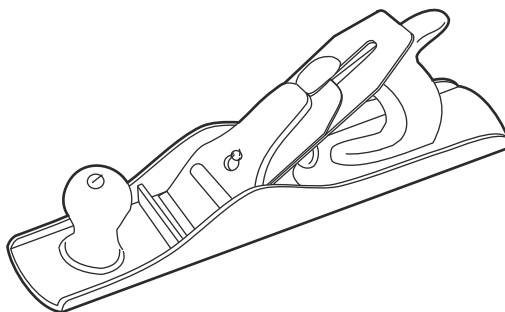

1

(d) The decorative front rail was manufactured on the machine shown below.

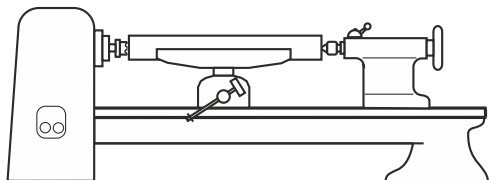

(i) **State** the name of this machine.

1

21.(d) (continued)

- (ii) The tool shown below was used to hold one end of the material on the machine. From the following list, **select** and **write** the name of this tool.

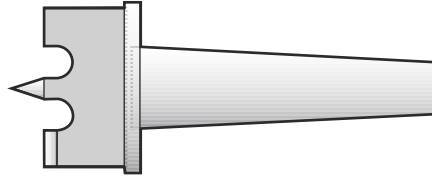

Driving fork

Parting tool

Facing tool

Live centre

1

-
- (iii) From the list below, tick (✓) **three** safety checks that should be carried out to the **machine before** switching it on.

- | | |
|--|--|
| <input type="checkbox"/> Chuck key removed | <input type="checkbox"/> Material turns freely |
| <input type="checkbox"/> Safety goggles are worn | <input type="checkbox"/> Speed set correctly |
| <input type="checkbox"/> Apron on | <input type="checkbox"/> Hair tied back |

3

22. A child's game is shown

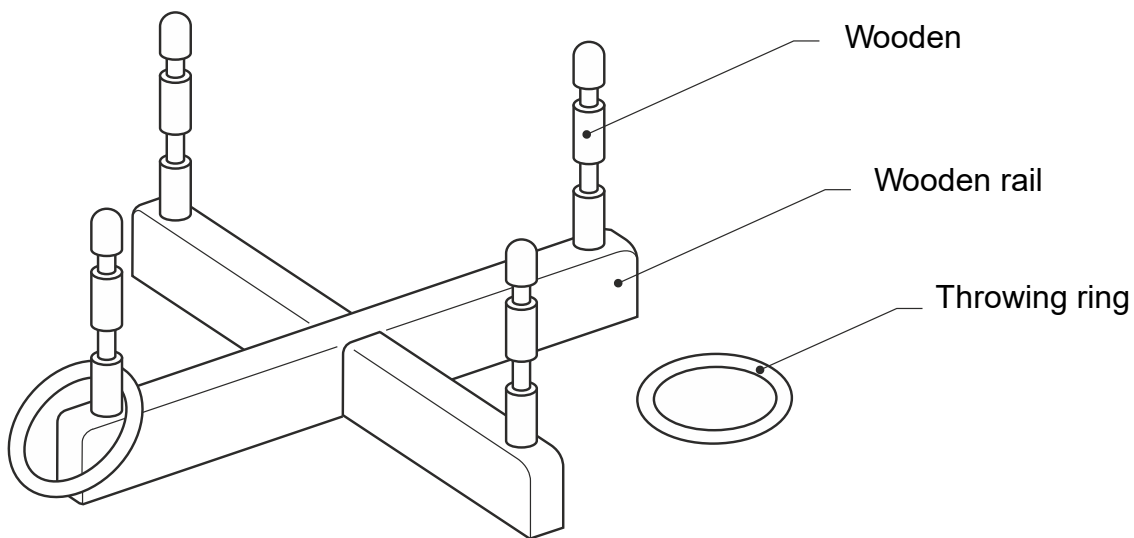

- (a) The rails and pegs are to be made of a hardwood.
State the name of a suitable hardwood.

1

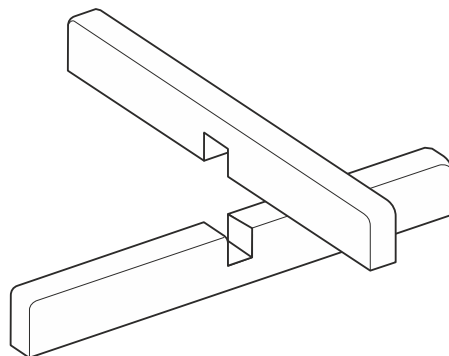

- (b) State the name of this joint.

1

22. (continued)

- (c) The following tools were used in the manufacture of the joint.
State the name of each tool.

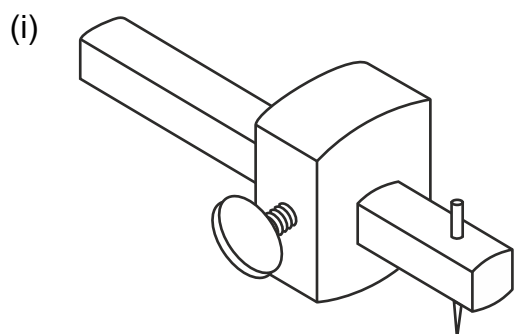

Tool name _____

1

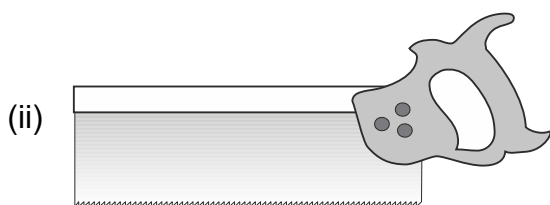

Tool name _____

1

- (d) A wooden peg is shown

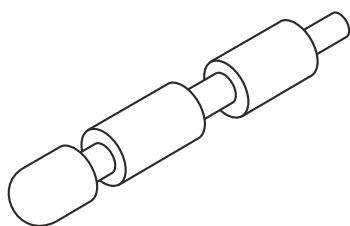

State the name of the machine used to manufacture the peg.

1

22. (continued)

(e) The tools shown below were used when manufacturing the peg.

(i)

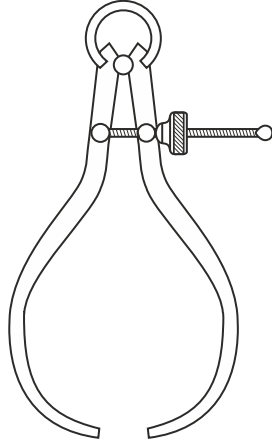

Tool name _____

(ii)



Tool name _____

1

1

23. A covered sand pit table for a nursery is shown.

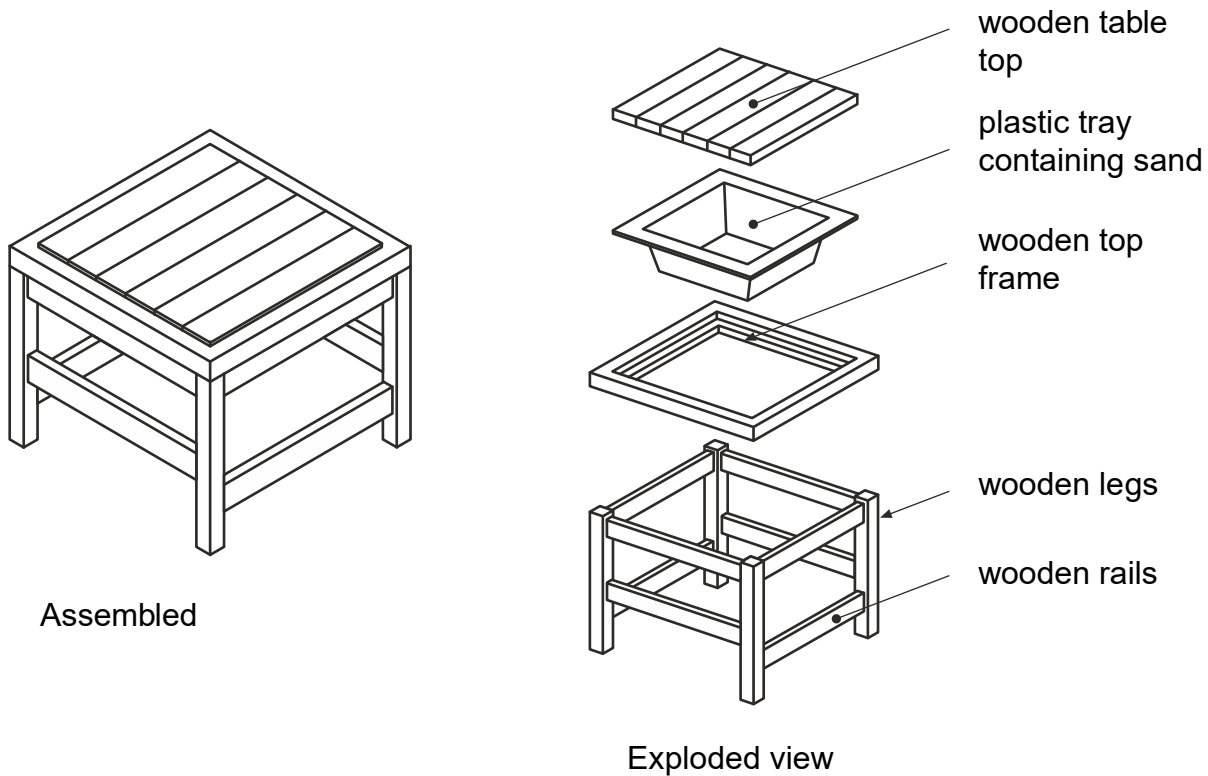

(a) The joint shown was used in the manufacture of the table.

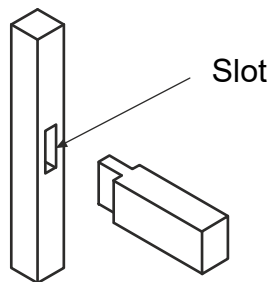

(i) State the name of this joint.

1

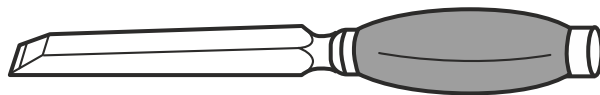

(ii) State the name of this type of chisel.

1

(iii) Describe how to ensure that the slot in the leg is cut to the correct depth.

1

23. (continued)

- (b) State the name of a white coloured wood glue used in the assembly of the wooden table.

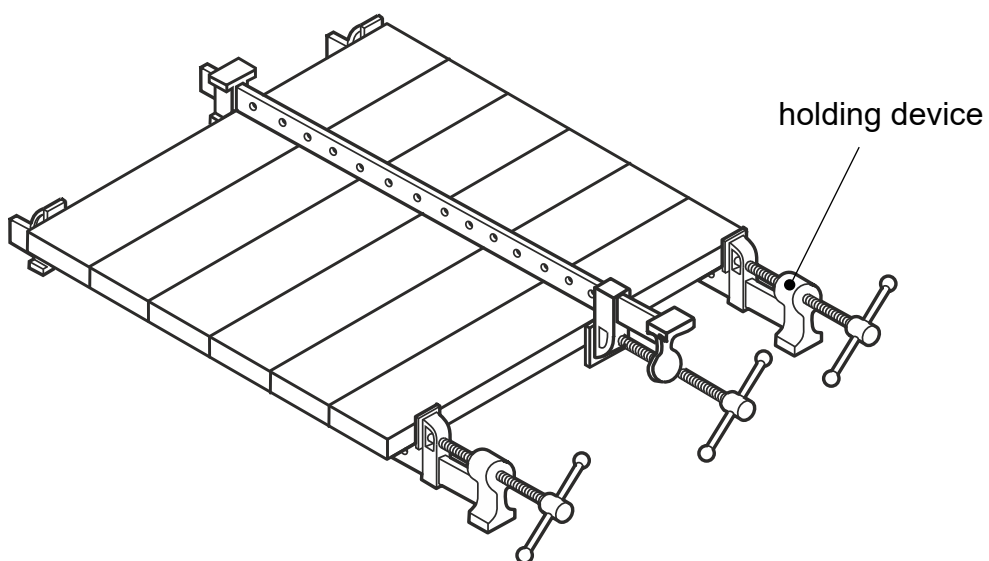

- (ii) State the name of the holding device.

1

1

23. (continued)

(d) The top frame is shown below.

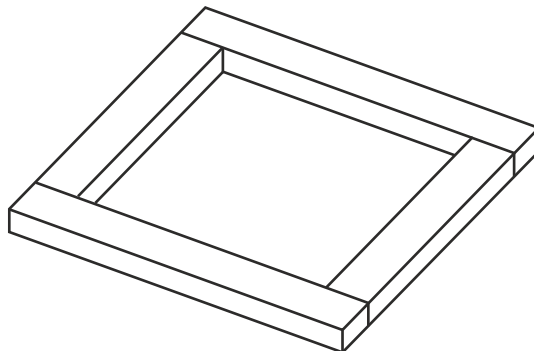

State two methods of checking that the frame is 'square'.

1. _____

2. _____

(e) State a suitable finish that could be applied to show the natural grain of the wood.

2

1

24. A TV unit made from MDF is shown below.

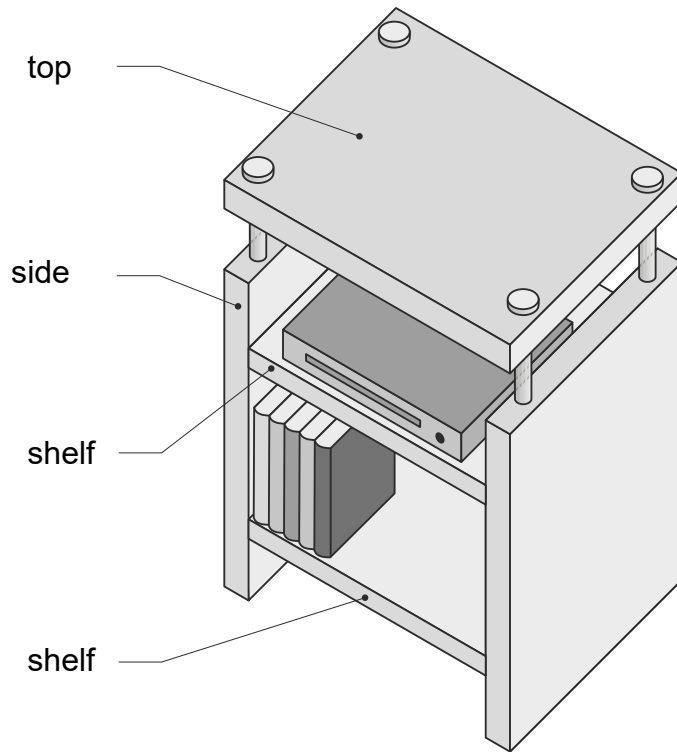
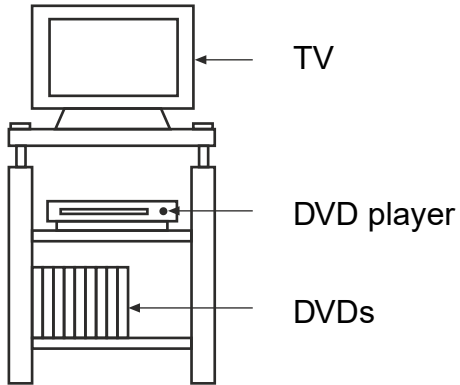

(a) A cutting list was made for the TV unit.

State two pieces of information that would be found on a cutting list.

1. _____

2. _____

24.(continued)

(b) A butt joint was considered for the unit as shown below.

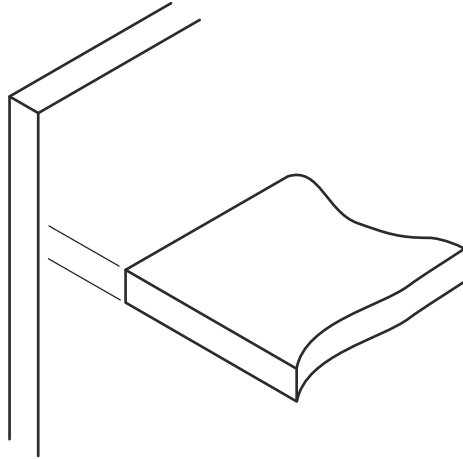

State a reason why this joint was rejected.

1

(c) The joint shown below was used to join the shelves to the

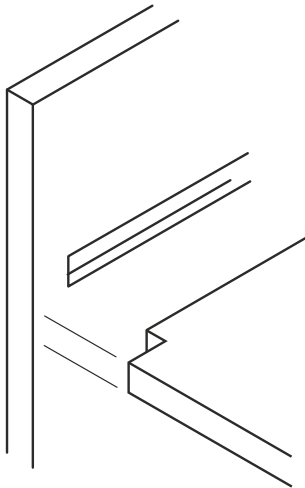

(i) State the name of this joint.

1

24. (continued)

- (d) A hand router was used to finish the bottom of the joint.
- (i) With reference to the sketch below, describe how you would set this tool to finish the joint to a depth of 10 mm.

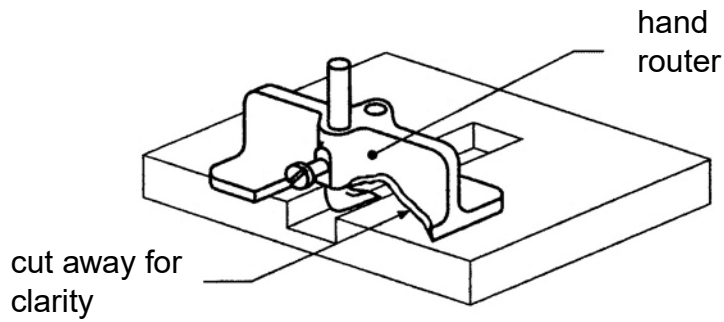

2

- (ii) State **one** reason why a hand router, rather than a chisel, would be used to flatten the bottom of the joint.

1

25. A child's toy bike is shown

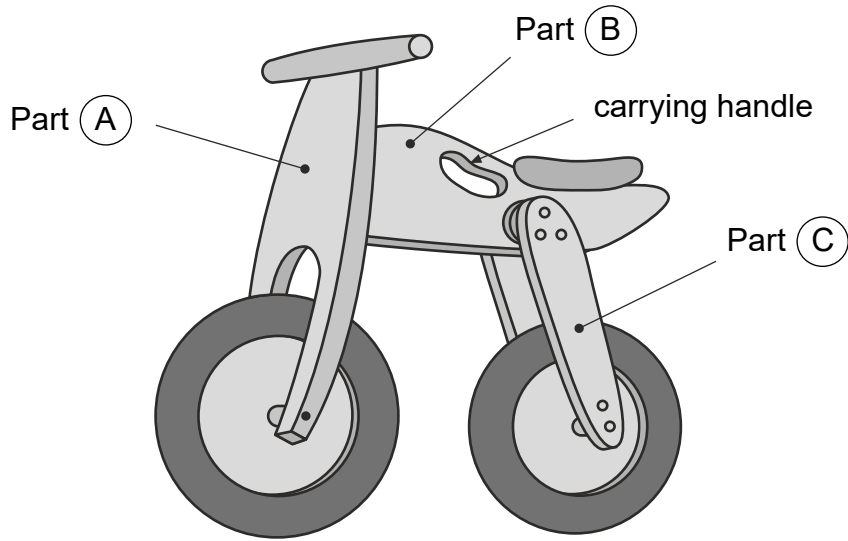

(a) Parts A , B and C are made from plywood.

State **two** reasons for this choice of material.

1. _____

2. _____

2

(b) State the name of a **machine tool** that could be used to cut the shape of Part A.

1

(c) An incomplete sequence of operations for the manufacture of the carrying handle is shown.

(i) Explain how a coping saw can be used to cut out the carrying handle in Part B

Step 1 mark out waste using a template

Step 2 _____

Step 3 _____

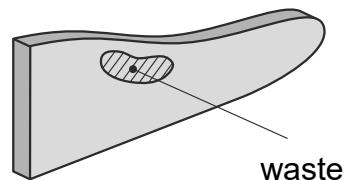

2

25. (c) (continued)

- (ii) Describe **how the coping saw is adjusted** when cutting the outline shape of the carrying handle.

2

- (d) Part C, the rear forks, were made in pairs.

State **one** method of ensuring that both parts are identical.

1

- (e) Holes of the type shown below are made in the rear

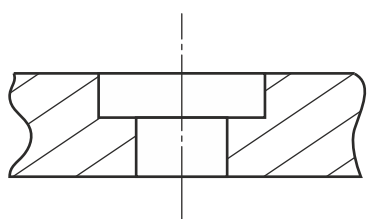

Sectional view of hole

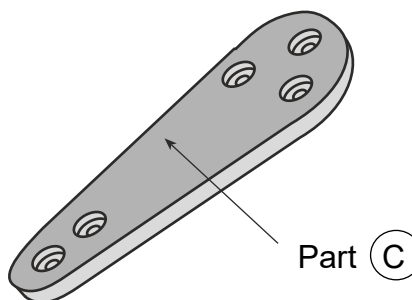

The tools shown below were used to drill the holes in the rear forks.



Tool 1

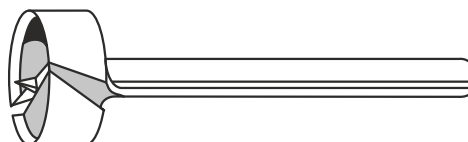

Tool 2

- (i) State the full name of each tool.

Tool 1 _____

Tool 2 _____

2

25.(e) (continued)

- (ii) State a reason why tool 2 was used before tool 1 when drilling the holes.

1

- (f) Name a suitable method of joining the handlebar to Part A .

Name of joining method

1

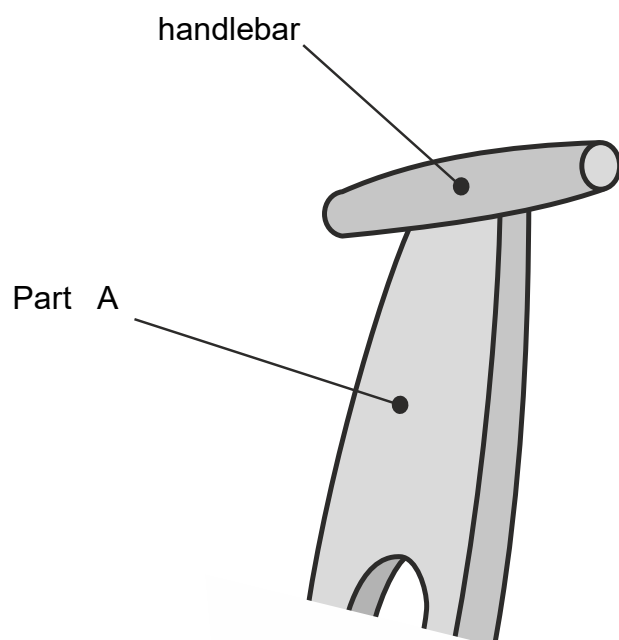

- (g) The bike was finished in primary colours.

State one reason for using primary colours.

1