



What do you think the world's smallest working bicycle looks like?

See over for answer ▶

Amazing bike facts!

The penny-farthing, also known as a high wheel, high wheeler and ordinary, is a type of bicycle with a large front wheel and a much smaller rear wheel. It comes from the British penny and farthing coins, one much larger than the other, so that the side view resembles a penny leading a farthing.



Memory test

A few years ago, most historians thought that Pierre and Ernest Michaux, the French father and son team of carriage-makers, invented the first bicycle during the 1860s.

Historians now disagree since there is evidence that the bicycle (and bicycle-like vehicles) are older than that. Historians do agree that Ernest Michaux did invent a bicycle with pedals and cranks in 1861. However, they disagree if Michaux made the very first bike with pedals. Another untruth in bicycle history is that Leonardo Da Vinci sketched a design for a very modern looking bicycle in 1490. This has been proven to be untrue.

Now turn over and answer the questions on the reverse ▶

Word search

PLEASE DO NOT WRITE ON THIS CARD

A	F	H	J	K	L	C	U	B	C
S	F	O	X	U	T	H	J	B	S
W	F	B	R	M	A	A	O	O	E
L	U	N	G	K	R	I	Q	X	K
P	E	D	A	L	S	N	S	A	A
S	B	N	H	Y	R	F	C	I	R
M	U	D	G	U	A	R	D	V	B

Can you make a bike?

Can you construct a bicycle from pieces of bendy wire or rods? The wheels have to be able to move and the handlebars must turn! You can also use old matchsticks, Lego etc.



1

EXA 2-04a, TCH 2-12a, LIT 2-14a



Memory test

1. Which country was Pierre Michaux from?
2. What was his son's name?
3. Leonardo Da Vinci sketched the first bike. TRUE or FALSE

Answers at the bottom of the page ▼

Manoeuvring

Put the following actions in order when overtaking a stationary vehicle:

Manoeuvre, two hands on handlebar, lifesaver, signal, look

Answers at the bottom of the page ▼

2



EXA 2-06a

Design a bike

Imagine you are going on a long expedition to a very rugged and mountainous country. You will be travelling through swamps, mountains, deserts and maybe deep snow! Design and draw a one, two, three or even four wheeled cycle that would get you there and back safely and in comfort.



The world's smallest working bicycle

Answers

Manoeuvring

look, signal, two hands on handlebar, lifesaver, manoeuvre

Memory Test

1. France 2. Ernest 3. False



Amazing bike facts!

This bike is made of 24ct gold!
Can you guess how much it costs?

[See over for answer ►](#)



**When manoeuvring,
a lifesaver is the final
look back over your
right shoulder to see
if it's safe.**

Discussion topic

“Everyone who lives within three miles of work or school should cycle rather than take a car or a bus or any public transport.”

Take a piece of paper and draw a line down the middle. Write down the advantages of this statement on the left side and the disadvantages on the right. Share your thinking with a friend. Do they feel the same as you? Why?



Sir Chris Hoy

Sir Chris Hoy has won six Olympic Gold medals in cycling.

He has also won eleven world championships! He is one of our most successful athletes ever!



3



LIT 2-09a



Amazing bike facts!

This bike costs £650,000!

Handcrafted and overlaid with pure 24ct gold, only thirteen were made, each one customised to the buyer's needs. For extra glitz, the maker's logo is picked out in 600 black diamonds and 500 golden sapphires.

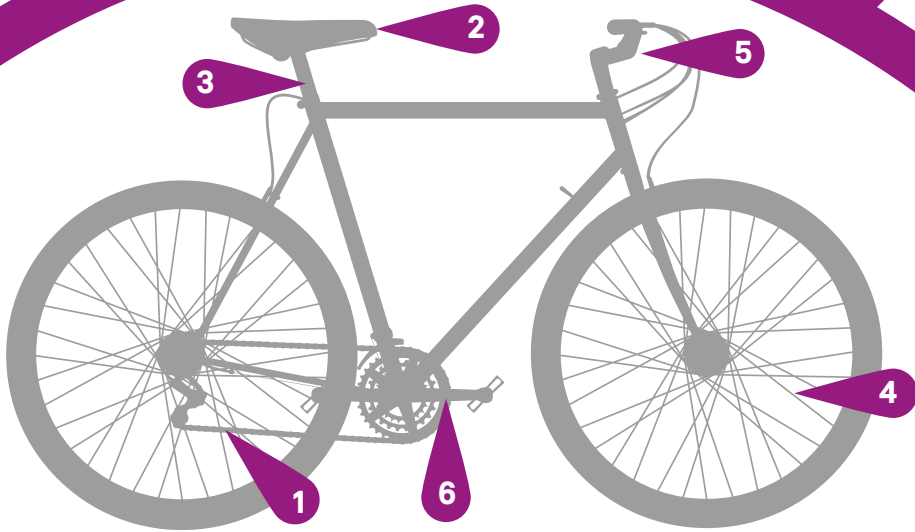

Missing words

Fill in the spaces below using the words at the bottom...

At night, _____, motorbike and bus drivers will have more difficulty seeing you in the _____.

Using front and rear lights, and wearing light coloured clothing will make you more _____.

car / visible / darkness

4



LIT 2-16a



Can you label the parts of this bike?

- 1. _____
- 2. _____
- 3. _____
- 4. _____
- 5. _____
- 6. _____

1. Chain 2. Saddle 3. Seatpost 4. Spoke
5. Handlebars 6. Crank

Answers



Amazing bike facts!

There are about one billion bicycles in the world, more than double the amount of cars.



5



LIT 2-01a, LIT 2-20a



**Check out these old bicycles above.
What has changed from then until now?
How comfortable would they have been?**



Write your own story

Write a story on one of the following (made up!) events...

Girl becomes fastest ever bicycle rider!
Stolen bike recovered by school pupil.
Amazing riding skills as school pupil joins circus!

(Or make up your own event)



Complete the limerick...

A little old man called Spike,
Went out for a ride on his bike...

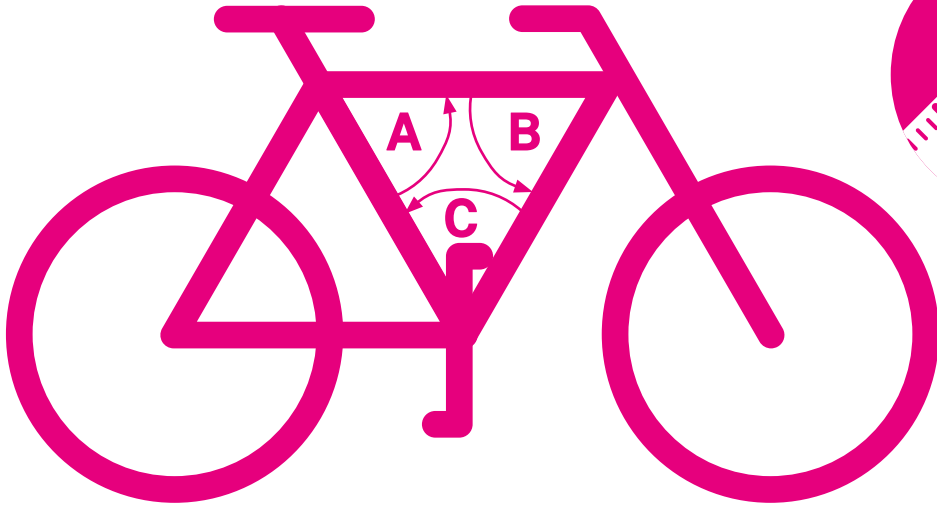

Measure the angles

Measure the angles of the bike frame A, B and C and then add them up. What number do you get?

Compare your answer with the one at the bottom of the page. ▼

Measure the angles
180 degrees

Quick questions

The two positions are called 'primary' and 'secondary'. Primary position is further out in the road, and secondary position is closer to the pavement.

True or false?

1.True 2.False 3.False 4.True 5.True

Answers



Amazing bike facts!

The Netherlands has more bike users than any other country, with almost 30% of all trips across the country being made by bike.

6



MTH 2-17b

Quick questions



What are the two standard positions for riding on roads and is there a difference?

True or false?

1. The modern bicycle was first seen in the 1860s.
2. Early bicycles were made of plastic.
3. Bicycles use more energy than cars.
4. Cycling three times a week keeps you healthy.
5. Mountain bikes usually have more gears than BMX bikes.

Answers at the bottom of the page ▼

Cycling three hours or 30 kilometres per week halves your risk of heart disease and strokes.





Bicycle safety

Look at the bicycle in the picture.
Can you name all the safety devices on this bicycle?

7



LIT 2-14a

Word search

PLEASE DO NOT WRITE ON THIS CARD
Can you find the following words:

- Signal
- Lifesaver
- Primary
- Look

W	K	P	Y	S	I	G	N	A	L
E	V	R	Z	P	U	F	F	H	S
G	L	I	F	E	S	A	V	E	R
S	T	M	C	V	N	O	L	M	Q
L	J	A	T	E	L	B	O	D	L
I	G	R	S	S	O	N	O	X	C
U	F	Y	H	D	T	M	K	V	P



Electric-operated tricycle

Powered by a generator and an electric motor.
Who might this tricycle be useful for, and why?



Cycling for an hour can burn over 250 calories! This is the same amount of calories as a hamburger.

Amazing bike facts!

In the late 1700s a Frenchman named Comte de Sivrac invented the Celerifere, a wooden hobby horse made of two wheels and joined by a beam. The rider would sit on the beam and move by pushing his or her feet against the ground. On bumpy ground, this must have been very, VERY uncomfortable!!!



Quick question

Which of the following crossings can you cycle across:
Toucan crossing?
Pelican crossing?

Answer below ▼



8



MNU 1-03a



Quick question

How many spokes does this wheel have?
(Tip: You can use the quarters to help you!)

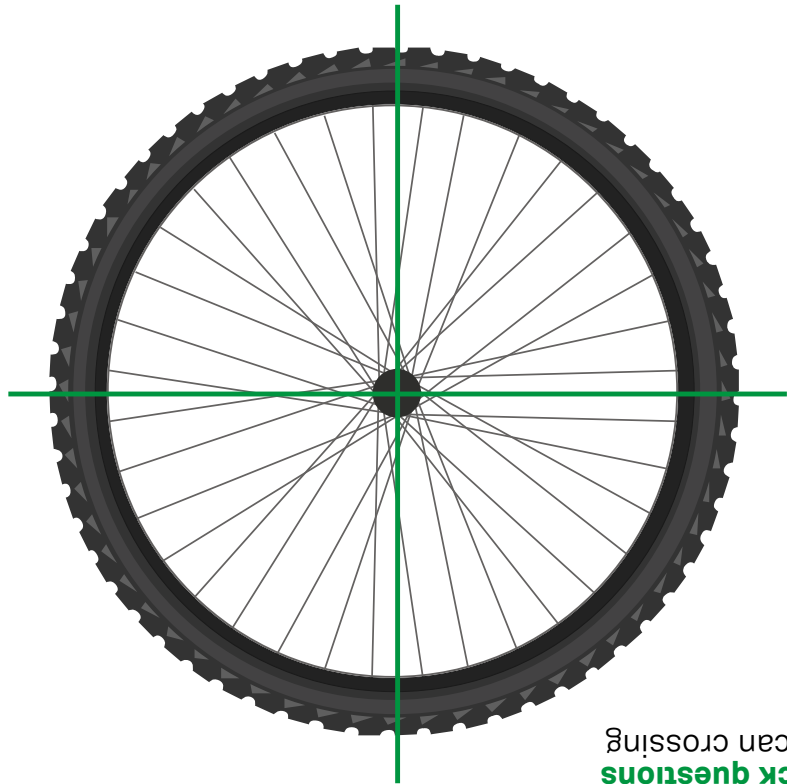

Quick questions
Toucan crossing

Design a bike frame

Here is a bicycle frame. Can you copy it and design a special colour scheme for it?

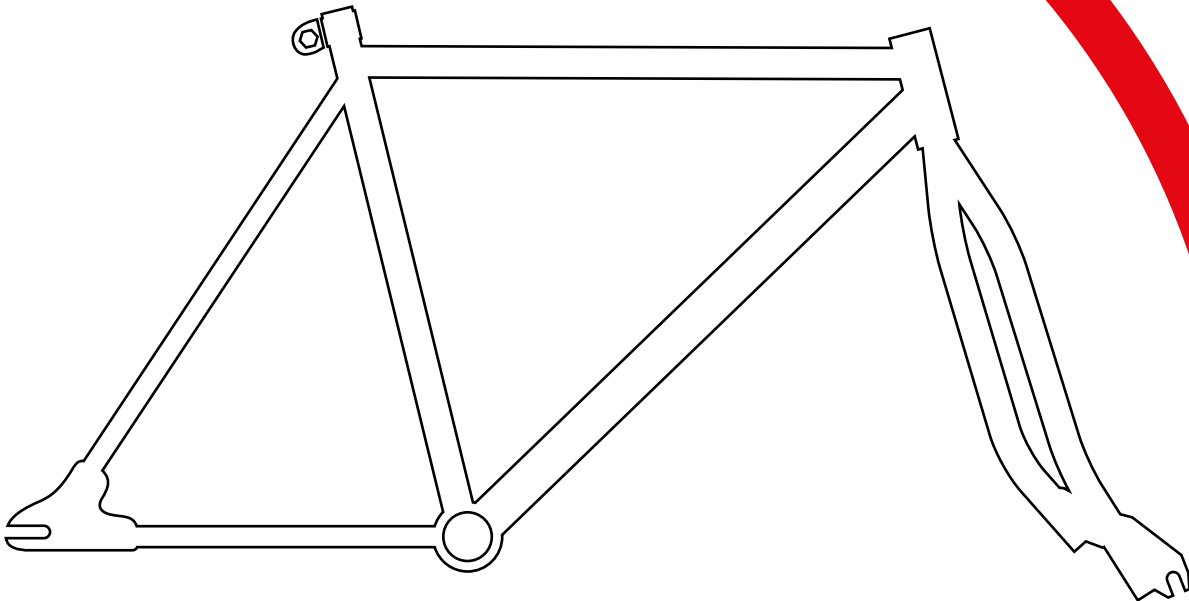

Amazing bike facts!

On a bike you can travel four times faster than you can walk, using a fifth of the energy!

4x

9



Quick questions

Can you describe an emergency stop?

What is the “pedal ready” position?



Road signs

Use the internet to look up what these road signs mean.

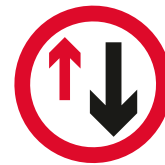

Concept bike

This bike is called a “concept bike”. It is designed by people who like to imagine what bikes of the future will look like. This could be the folding bike of the future.



Quick question

If it takes 250 turns of the pedal (rpm) in order to cycle 1km, how many turns will it take to cycle 100km? How many from your home to school? From your school to Paris? To the moon?!



Whichever position you are riding, you should always remember 'COPS'. Finish these words.

Contr..
Obse.....
Pos.....
S.....

Amazing bike facts!

You weigh about seven times more than your bike. A car weighs around thirty times more than you do, and can often go no faster.



PLEASE DO NOT WRITE ON THIS CARD

1.		2.			3.		
							4.
	5.						
6.							
7.			8.				
9.							

Crossword

Across:

- 1. How you tell other road users that you are going to turn.
- 5. What you use to slow down or stop on a bike.
- 7. Passing a stopped or very slow vehicle.
- 9. Your position on the road.

Down:

- 2. This makes pedalling up steep hills easier.
- 3. The final look before a manoeuvre.
- 4. This can help protect your head from injury.
- 6. Sir Chris ... won a lot of Olympic gold medals for cycling.
- 8. Give plenty of this when overtaking another bike.



ENG 2-12a, LIT 2-09a



Discussion topic

With a partner, discuss the times when it would be better to get off your bike and push it.

Word quiz answers
Control
Observation
Position
Speed

Crossword answers
Across: 1. Signal 5. Brake
7. Overtake 9. Primary
Down: 2. Gear 3. Lifesaver
4. Helmet 6. Hoy 8. Room

Quick question

A lifesaver is the _____ look back over your shoulder to see if it's _____.

Answer below ▼

Amazing bike facts!

On a bike you can have your cake and eat it. A moderate hour of cycling will burn eight calories a minute, or the equivalent of 11kg of fat in a year.



The top ten

Here are the top ten European countries that use bicycles the most:

- | | |
|----------------|-------------------|
| 1. Netherlands | 6. Belgium |
| 2. Denmark | 7. Germany |
| 3. Hungary | 8. Slovenia |
| 4. Sweden | 9. Czech Republic |
| 5. Finland | 10. Slovakia |

Biggest bike

It took three months for Wouter van den Bosch, a Dutch art student, to build this 750kg mega-bike. He became the proud owner of the biggest rideable bicycle in the world.



11



EXA 2-06a



Design a bicycle

Look at the bicycle to the left. It has a tractor tyre for a front wheel! Can you design and draw a bicycle which uses parts of other machines?

Remember, it has to be rideable!

Use a die and try to get home from school. If you throw a six, you get another turn.
 You can play yourself or with your friends (it's just like snakes and ladders!).
 You will need a die and counters for each player.

41 Lights not working- go back to square 22.	42 	43	44 Use the bike lane. Move on three places.	45	46	47	48 	49	50  HOME
40	39	38 	37	36 Traffic lights green. Throw again.	35	34 	33	32	31 Wrong turn. Back two places.
21 	22	23	24	25 Passed your maths test, move on four places.	26 Puncture, miss a turn.	27	28 	29	30
20	19 	18	17 Toucan crossing empty, move on six places.	16	15 	14 Dropped school books, move back three places.	13	12	11
1 START	2	3 	4	5 Downhill road, move on five places.	6	7	8 Traffic Lights at red, miss a turn.	9	10 



Amazing bike facts!

On a bike you are, in terms of energy used per kilometre travelled, the most efficient of all moving animals and machines.

13



TCH 2-03b, SOC 2-14a



Electric bicycle

An electric bicycle, also known as an e-bike or booster bike, is a bicycle with an electric motor. There are a great variety of e-bikes available worldwide, from e-bikes that only have a small motor to assist the rider's pedal-power, to more powerful e-bikes. All, however, have the ability to be pedalled by the rider.

E-bikes use rechargeable batteries and the lighter varieties can travel up to 20mph, depending on the laws of the country in which they are sold. In China, they are replacing petrol mopeds and small motorcycles.



Map making

Make a map of your school and the roads around it. Then highlight all the paths and roads that are safe to cycle on.



Quick question

There are at least 21 different types of bicycle (and many variations of these!!!). How many can you name?
Here's a few to get you started: BMX, track, touring
Tip: you can look this up online.



14



Jigsaw

Using a photocopy of the picture to the left, make a jigsaw by cutting on the lines marked, and try to put the picture back together again.

Le Tour de France

15



LIT2-11a

Amazing bike facts!

The closest race ever was in 1989. Greg LeMond beat Laurent Fignon by only 8 seconds.



Amazing bike facts!

The Tour de France is the world's largest annual sporting event!



Women's cycling

Women's professional road cycling is becoming more and more popular, but at the moment it doesn't receive as much money and attention as men's cycling. For example, in the 2015 Tour of Flanders cycling race, the winner of the men's race won €20,000, but the winner of the women's race only won €1,213.

Famous female cyclists from Scotland include Katie Archibald and Aileen McGlynn.

Can you use the internet to find their photos and see if you recognise them?

Amazing bike facts!

The course changes every year, but on average the whole race is around 3,360 kilometres long. Scotland measures 441 kilometres from north to south!! The longest ever Tour de France was a whopping 5746 kilometres!



Amazing bike facts!

The winner of the Tour de France receives a prize of around £320,000 (the winner of the men's Wimbledon singles title receives around £1.88 million).



Le Tour de France



16



MTH 2-10c, 2-11b

Tour de France quiz

(You may need to look on the internet to find some of the answers to these questions.)

Think of the most recent Tour de France race, and answer the following questions.

1. How many stages were there?
2. Who won the yellow jersey?
3. How long (in kilometres) was it in total?
4. How many teams entered the race and how many individual riders?
5. How many water bottles were used in this year's race?
6. Who was the oldest rider to win a stage?
7. Who was the first British rider to win the Tour de France?



If a stage of the Tour de France is 150 kilometres and a rider averages 20 kilometres per hour, how long will it take him to complete the stage?

How many words can you make up using the letters from the words Tour de France?

You may only use each letter once!
0-6 Good
7-12 Very good
13-20 Excellent!
More than 20.... Wow!!!



42,000 water bottles were used during the race. If each bottle contains 750ml, how many litres of water were drunk in total?



If you cycled for 3,360km from your house in a straight line, where would you end up?



Le Tour de France

17



Amazing bike facts!

The average rider will burn the same number of calories as eating 20 double cheeseburgers during each stage.



Amazing bike facts!

The leader's jersey is yellow, the top sprinter wears green, and the most impressive young rider wears white. The best mountain racer wears a red and white spotted jersey.



Amazing bike facts!

Around 12 million people come to watch the race every year.



Amazing bike facts!

The first British rider to win the race was Bradley Wiggins in 2012. Chris Froome won the following year.

Le Tour de France

18



HMB 2-30a, TCH 2-03b

Quick question

A road racing bike weighs how much?

- About 22kg?
- About 18kg?
- About 7kg?

Answer
About 7kg



Quick question

Which of the following special jersey colours IS NOT worn by riders?

- Green, Red, Polka Dot, Yellow, Pink, White, Blue

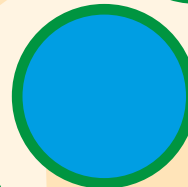
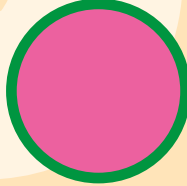
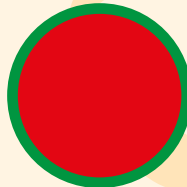

Quick question

Which country has won most Tour de France races?

Here's a tip:



Quick question

Each rider will eat 6000 calories every day of a race.

How many calories are recommended for you each day?



Signalling

In the Tour de France they navigate corners very quickly. Can you work with a partner and demonstrate:

Signalling to the left and signalling to the right

Mountain biking

Scotland is one of the best places on the planet for mountain biking. The network of exciting and challenging world-class trails in Scotland's forests help make the country such a big hit on the mountain biking world map.

Can you think of a place near your home that's suitable for mountain biking?

Amazing bike facts!

On a bike you can travel up to 1037 kilometres on the energy you'd get from a litre of petrol.



Spot the difference

Look at the road bike and the mountain bike below.

What are the differences?



Design a jersey

Design your own team bike jersey. Just copy this drawing and get started!



The Highway Code



First seen in 1931 and cost one old penny (under half of 1p). It included advice to drivers of horse-drawn vehicles to 'wave the whip above the head; then lean the whip to the right or left to show the direction in which the turn is to be made.' It only showed ten road signs. Cyclists were hardly mentioned.

Today's Highway Code has a section of rules just for cyclists. How many rules can you find in the Highway Code?

20



Amazing bike facts!

On a bike you travel more freely than any other vehicle in city traffic.



Looking after your bike

Looking after your bike in four easy steps ...

1. **Keep the tyres fully inflated.**
2. **Use your bike regularly.**
3. **Lubrication - little and often, less is more.**
4. **Have your cables (wires) at the correct tightness (you may need an adult to show you how to do this the first time).**
5. **Check the brake pads.**



Quick question

What do you think this picture is saying?

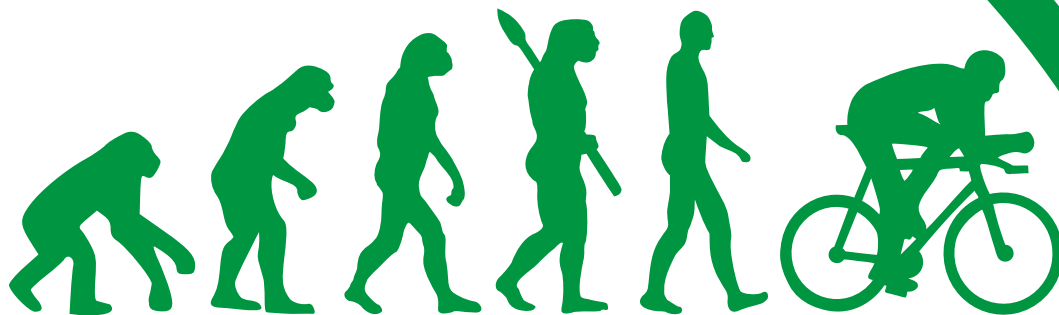



Tyres

Rubber tyres that have air in them are called pneumatic (sounds like: newmatik) tyres and they were invented by a Scotsman called John Dunlop in about 1880. The first bike pump was invented a little later.

Amazing bike facts!

The pressure of the air around you is 14.69psi. The pressure in a balloon is around 15.60psi. The pressure in a bike tyre can be as high as 120psi.



Quick question

Can you find out the name of the two different valves used in bicycle tyres?

Answer below ▼



Bicycle maze

Can you draw a bicycle maze? You'll need squared paper, a pencil and an eraser. Once you've drawn it, swap with a partner and try to solve it...

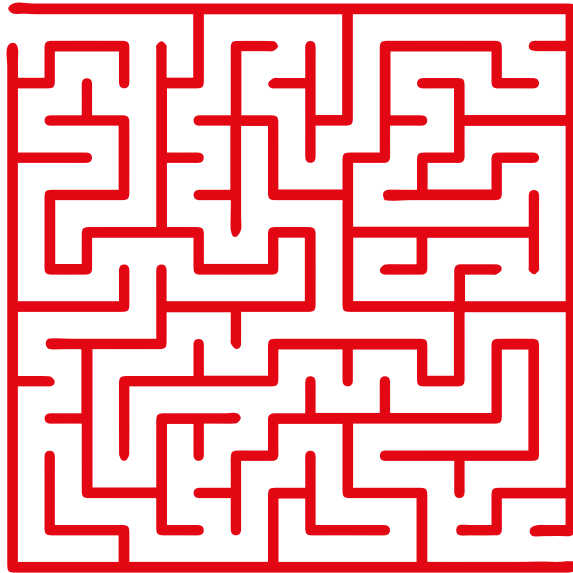

1.



2.



Answer: 1. Presta 2. Schrader

Discussion topic

Discuss with your partner the following:

Are you allowed to cycle on the pavement?

Heart rate exercise

Your heart beats about 35 million times in a year. During an average lifetime, the human heart will beat more than 2.5 billion times.

Ask a teacher or look up on the internet how to measure your heart rate (also called a pulse). Take your pulse before cycling, and then again just after you've stopped cycling.

Do you notice a difference? If it's changed, do you know why? Compare your findings with your friends.

Crazy bike records...

Kadim Shubber rode 891 miles from John O'Groats to Land's End with a skeleton on the back of his tandem.

Cycling and your health

Do you agree with any of the following statements? Compare your answers with a friend and explain why you do or don't agree with them.

- 1) **Cycling regularly will help you sleep better**
- 2) **Cycling can help you increase your brain power**
- 3) **You'll have a healthier heart if you cycle regularly.**

Crazy bike records...

Martin Tuson did 138 BMX front hops in 42 seconds (he's 47 years old!)

22

LIT 2-04a,

HWB 2-15a,

HWB 2-27a

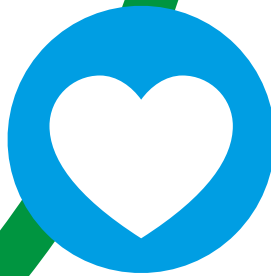

Pedestrians

When you're on your bike, you need to watch for pedestrians and others who may be using the path too.
What could you do to tell other users that you are there?

23



MTH 2-03a



Word search

PLEASE DO NOT WRITE ON THIS CARD

Can you find the five words in this word search, which all relate to health?

Answers below ▼

H	E	A	R	T	E	Y	V	J	L
E	F	C	X	S	B	U	F	A	T
A	B	K	A	S	L	P	M	O	G
L	B	C	A	L	O	R	I	E	S
T	E	D	P	L	O	V	I	G	K
H	Y	W	H	L	D	P	L	I	D
Y	T	S	M	Z	R	T	Q	R	U



Quiz

Bikeability Scotland is a scheme run by:

- A. Bike's R Us Scotland?
- B. Cycling Scotland?
- C. Great British Bike Company?



Crazy bike records...

Rodney Hines balanced on the back wheel of his bike without holding the handlebars for 1 hour and 30 minutes. He travelled 16 miles.



Answers: Heart, Healthy, Fat, Blood, Calories



Crazy bike records...

Brian Pankey balanced his bike on his forehead for 2 minutes and 48 seconds.

Don't try this yourself!



Quick question

Let's say you want to cycle across Africa by road at its widest point. That's from Hordio in the east to Dakar in the west.

If you cycle at an average speed of 6 miles per hour, how long will it take you?

Answer below ▼



24



MNU 2-20b, MNU 2-10c

Crazy bike records...

Art Hoffman completed a ¼ mile bike ride with his dog Chenji in 58.87 seconds.

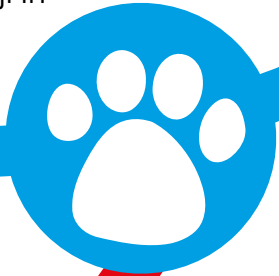

The Highway Code

Use your lights at night.
It's the law!



Survey

Carry out a class survey and find out how many people...

- Own a bike
- Cycle to school
- Cycle at home for fun
- Use their bike to travel around their town/village



Answer: The distance by road is 6,316 miles. Divide the distance by the speed and you get the answer: 1053 hours or 44 days if you pedal non-stop!



M

PLEASE DON'T WRITE ON THIS CARD

The M check

Here's how to do an M check:

- Start with the front wheel.**
- Move up to the handlebars.**
- Move down to the pedals and chainset.**
- Move up to the saddle and seatpost.**
- Move down to the rear wheel.**



Discussion topic

Discuss with your partner what you would be looking for with an M check on the following:

Front wheel, handlebars, brakes, pedals and chain, saddle and seatpost, back wheel, helmet, clothing



Lesson plan for teachers

Journey Planning – Maths/Social Studies focus

SOC 2-09A / SOC 2-14A / MTH 2-17C / MTH 2-17D / MTH 2-18A / HWB 2-18A

Introduction

The teacher models how to locate the primary and secondary school using a large map of the local area or one shown on an interactive whiteboard. The teacher should talk through how this is done e.g. using local landmarks, street names etc.

Discuss scale and how it can differ depending on the particular map; show a range of different maps. Additionally, familiarise the children with different map symbols and how these can be used when planning a suitable route. The Ordnance Survey website has some useful information on understanding scale and map symbols (www.ordnancesurvey.co.uk/mapzone).

Mark more than one route between the schools using different coloured pens so that children can compare them in the starter activity.

Starter Activity

Allow children time to think, pair, share what they think the quickest route is between the schools, feeding back reasons for their choice. Then ask children which they think is the safest route to cycle between the schools and why. Some points to consider are:

- Traffic flow at school run time
- Type of road (main road, quiet residential road etc.)
- Traffic calming in place?
- Cycle paths
- Personal safety

Main Activity

Children work in pairs on photocopies of maps to plot their own home and the safest route to cycle to secondary school. Children then write directions using street names and directional language. Children could also use Google Maps satellite and the street view facility to help them determine the most suitable route.

An online route planning tool such as Plot my Route (www.plotaroute.com/routeplanner) could also be used to plan the route and calculate the distance cycled.

Plenary

- Children will swap their directions with another child and check that they are able to follow them on the map and reach the desired destination.
- A class discussion to share issues they came across when planning their route would also be beneficial, time permitting.

Challenge

- Use an 8 point compass to write the direction of travel. The Ordnance Survey website has some useful information on using a compass (www.ordnancesurvey.co.uk/mapzone/map-skills)
- Children can apply their knowledge and skills by planning a different route such as to the local sports centre or as part of a school trip.

Support

- Provide a word bank of directional language and use mixed ability pairings.