

Greenfaulds High School

Technical Department

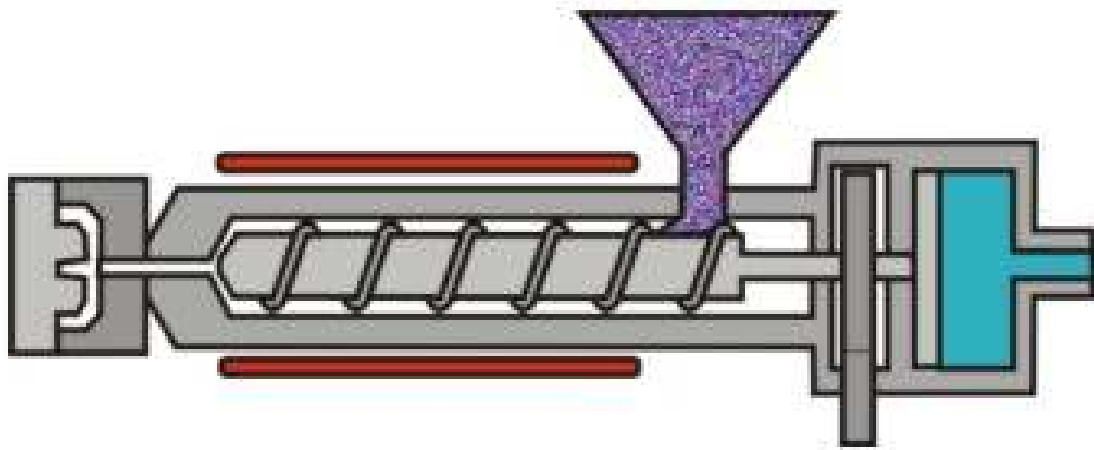

Standard Grade - Craft & Design

**Knowledge & Understanding
In
Plastic**

Plastics

The basic raw materials used in the manufacture of plastics are oil, natural gas and coal, but contrary to popular belief, plastics are not a new "space age" material. Natural plastics such as shellac, wax horn, pitch and bitumen have been known for thousands of years.

Just as timber is classified as either a softwood or a hardwood and metal as either a ferrous or non-ferrous, so plastics are classified into two main groups: **Thermoplastics** and **Thermosetting** plastics.

Thermoplastics

Thermoplastics soften when heated, can then be shaped, and then harden as they cool. With this type of plastic the softening and hardening can be repeated many times over. When a thermoplastic has been re-heated it will return to its original shape unless it has been permanently damaged by excessive heat or deformation. This characteristic of thermoplastics on re-heating is known as **Plastic Memory** (i.e. it remembers what its original shape was).

Thermosetting Plastics

As the name implies thermosetting plastics (or thermosets) set or solidify, when heated and cannot be returned to their original state by further heating.

Common Plastics

The following are descriptions of some of the more common types of thermo and thermosetting plastics in everyday use.

Acrylic

Acrylic materials are among the most commonly used thermoplastics in the school workshop and the material in which will most likely be the material used to manufacture any artefacts which are made. Often better known by its trade name "Perspex", acrylic is available in clear or coloured sheets, rods and tubes. Acrylic is easily scratched and therefore sheets are usually covered on both sides by protective paper or thin polythene. As has been explained acrylic can come to the workshop in many various forms.

Supply form

Round Tube
used as Pipes

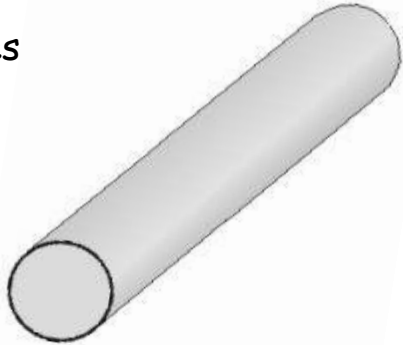

Round Bar
used for the
handle of a
screwdriver



Sheet used for
shop signs



Square Bar



Extruded strip
used for
curtain rails



Square Tube

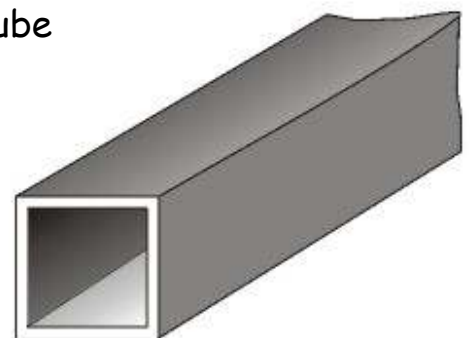

Table of commonly used everyday plastics

Thermosetting

Thermo

Properties	Hard, Heat Resistant	Hard, Heat Resistant	Hard, Heat Resistant	Stiff, Hard, Clear, easy cut, glued, polished, scratches easily.	Stiff, hard wide range of colours OR very light and buoyant.	Good colour range. stiff, hard OR soft & flexible.
Forms	Powder granules	Liquid Paste	Liquid Paste	Rod, tube and sheet in a wide range of colours.	Powders granules and sheet OR slabs and beads.	Powders, pastes & sheets
Uses	Electrical appliances saucepan handles	Bonding Gluing	GRP boats, car bodies, embedding	Car light units, shop signs, watch lenses.	Model kits, disposable cups OR Insulation and floats.	Pipes, guttering OR dip coating, floor tiles
Plastic	Phenolic Resin	Epoxy Resin	Polyester Resin	Acrylic	Polystyrene	PVC

Marking out Acrylic

As has been stated acrylic sheet is supplied covered with paper or polythene film to prevent scratching of the finished surface. Whilst the paper covered sheets can be marked with a pencil the polythene covered sheets, and unprotected sheets are best marked with a felt-tipped pen.

Cutting Acrylic

In the school workshop the most common method of cutting acrylic is by sawing. Fine toothed saws like the coping saw, hacksaw and junior hacksaw are the most suitable. Sawing must be done carefully and steadily to avoid chipping and splintering the material.

The band saw can also be used but is generally only to be used by the teacher.

Hacksaw

The hacksaw is used for general cutting of metal bar, tubes, etc. The blade is easily removed by slackening or tightening of the front wing nut.



Junior Hacksaw

This type of saw is also used for cutting metal but is used for light work or where a hacksaw is too clumsy.



Coping Saw

The coping saw is used to cut curves and other awkward cuts in plastic or wood. It is also unique as it is one of only a few saws which has its teeth facing backwards. In normal sawing the cut is made in the forward stroke but with the coping saw the cut is made on the backward stroke.

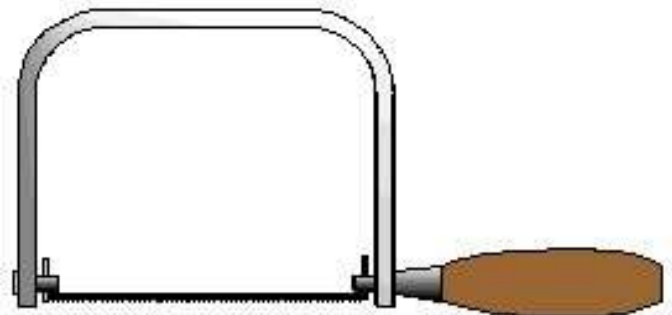

Files

Files are used to shape metal or plastic. They are available in a number of different shapes and degrees of roughness.



Files must not be used without a handle.

Sections of Files

Square

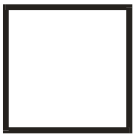

Round

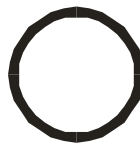

Half Round



3 Square Flat

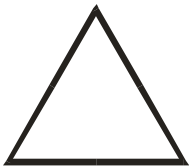

Stages in finishing an edge of acrylic

When acrylic plastics are cut they tend to have very rough edges, this is due to the fact that it is a very brittle material. Brittle means that although it is very hard, it tends to break easily especially when sawing. To ensure the plastic is finished with a clean smooth edge it is essential that the edges are finished in the following sequence.

- A** Cross file the edges to remove the majority of blemishes.
- B** Draw file the edges to remove the marks left from cross filing.
- C** Use wet and dry paper to get an overall smooth finish.
- D** Use acrylic or metal polish (Brasso) to achieve the final finish.
- E** Buff with a clean cloth.

Cross filing

In this type of filing the file is moved across the work piece using the full length of the blade. This method of filing is used for removal of a lot of material with every stroke applied.

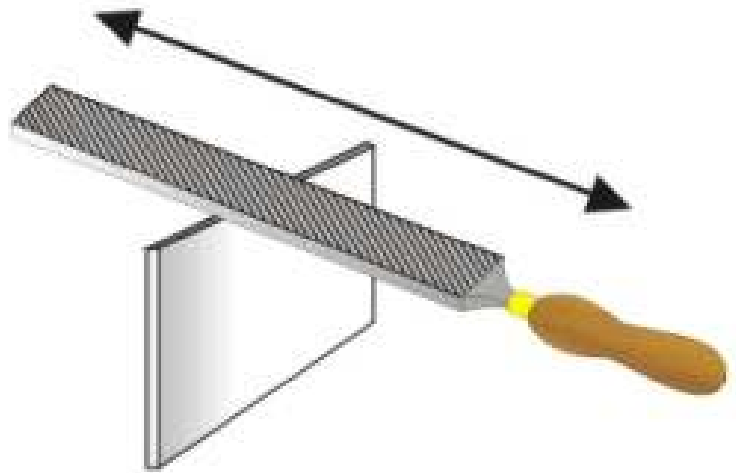

Draw filing

In this method of filing, the file is moved sideways along the work piece and is used to obtain a smooth finish after cross filing. This method does not remove much material.

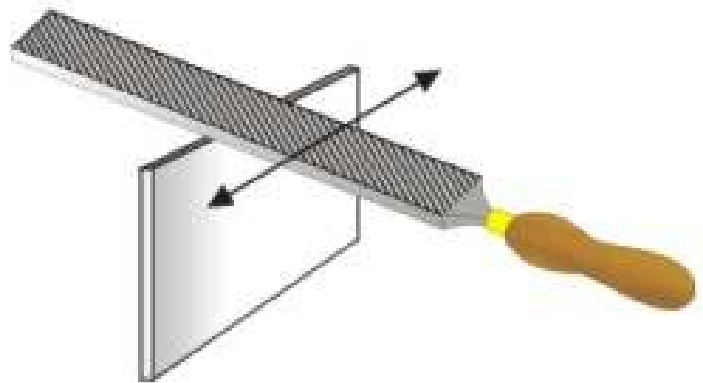

Cleaning the file

Small pieces of plastic can get trapped in between the teeth of the file. This is called **PINNING**. A **FILE CARD** can be used to clear the file of the excess material. The file card looks very similar to a wire brush except the teeth are very short.

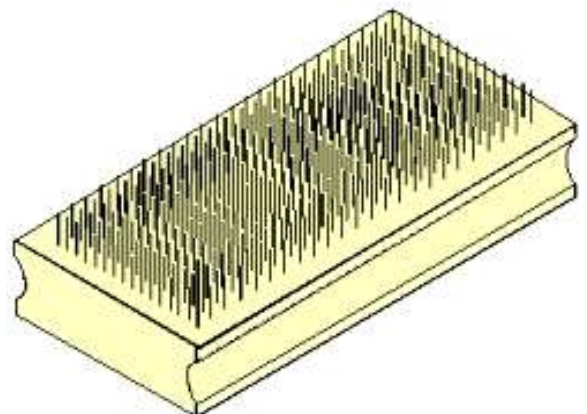

Drilling Acrylic

Holes can be drilled or cut in acrylic using standard drilling equipment, twist drills or hole saws.

Twist Drill

Twist drills are generally made from or carbon steel and are used for drilling circular holes in metal, plastic or wood. The most common type of drills used are the TWIST DRILLS. These drills have three basic parts, a point, a parallel body and a shank which can be either parallel or tapered.



Hole Saw

This tool is used to drill big holes in wood or plastic and is generally fitted to an electric drill. The hole saw has a centre drill attached which is called the PILOT drill. It is called the pilot drill as it pilots the larger diameter cutter to exactly the right location.



Epoxy Resin (Araldite)

In the table on page three it was seen that epoxy resin comes as a liquid paste. The picture shows the form in which it generally purchased



Bending and Forming Acrylic

Acrylic becomes soft and pliable when heated to approximately 150 °C. In this state it can be easily bent and formed to shape. On cooling to room temperature the formed shape is retained. The most convenient method of heating, prior to bending and forming, is to use the strip heater or oven.



The Oven

Where more complex shaping of acrylic is required it is necessary to use an oven for heating. For a 3mm thick sheet of acrylic the oven should be set to a maximum temperature of 170°C and the sheet heated for about 15 - 20 minutes before forming to the required shape.

Safety with Plastics

Working safely with plastics, like most other materials, requires sound common-sense and the observation of safe working practices. The following is a list of the more obvious safety precautions that should be noted.

1. When machining acrylic (i.e. sanding, sawing, drilling, etc.) eye protection and dust masks should be worn. Sheet material should be securely held in suitable vices or jigs.
2. On no account must hot thermoplastics be allowed to touch skin or clothes. When plastic dip coating, for example, stout leather gloves must be worn.

The Strip Heater

The purpose of the strip heater is to heat only a narrow strip of acrylic to allow local bending. Before bending the acrylic the protective coating is removed and then area to be bent is marked with a pen. After heating it sufficiently the acrylic can be shaped, preferably using a suitable former or jig.

The sequence diagrams shown below illustrate the four main stages of bending a piece of acrylic.

The first stage is to mark the line where the bending will take place.

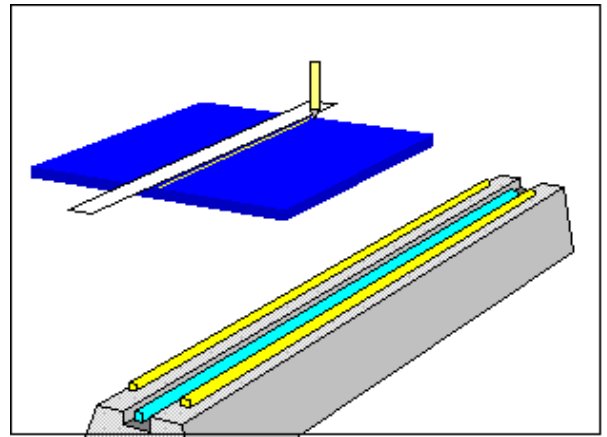

The second stage is to place the acrylic over the heating element, turning regularly to avoid burning.

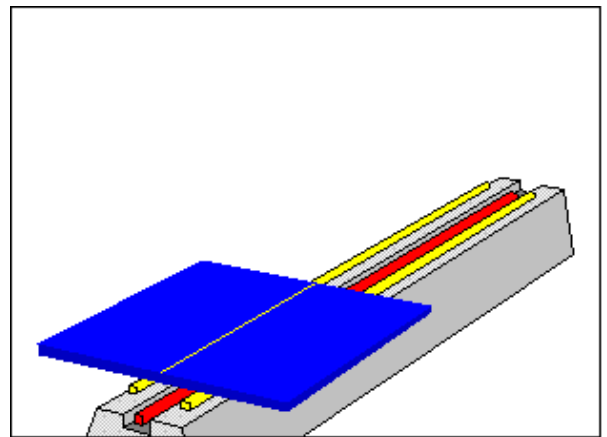

The third stage is to remove the soft heated acrylic and place it on a suitable JIG or FORMER.

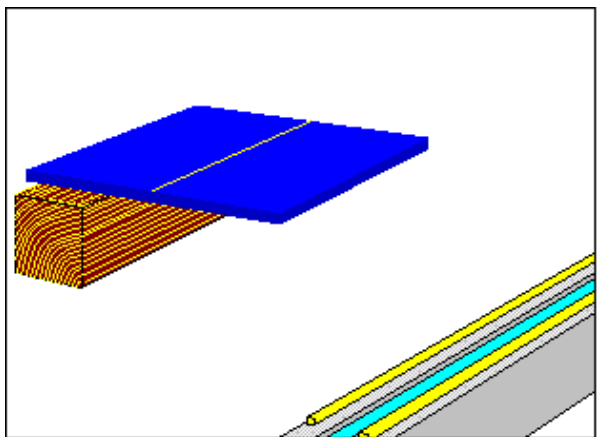

The last stage is to bend the acrylic to the desired shape.

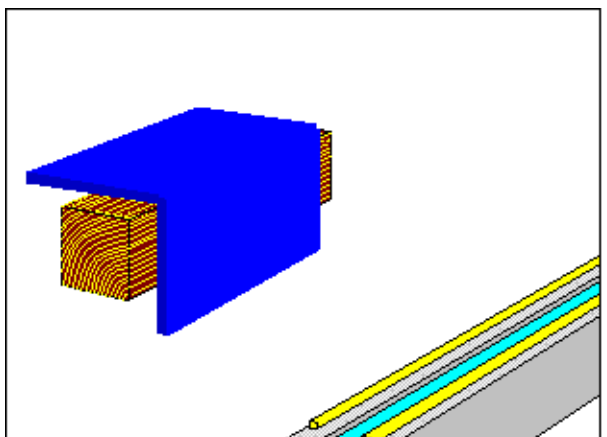

Vacuum Forming

In Vacuum Forming, a sheet of thermoplastic held in a clamp is heated until soft and flexible. Air is sucked out from underneath the sheet so that air pressure pulls the sheet down onto a specially made mould. This process enables thermoplastics to be formed into complicated shapes such as packaging, storage trays and seed trays.

The first stage of vacuum forming is to clamp the sheet across the top of the machine and heat it until the plastic is soft and flexible. This can be judged by watching the material, which will start to sag under its own weight when soft. If touched with a stick it will feel soft and rubbery.

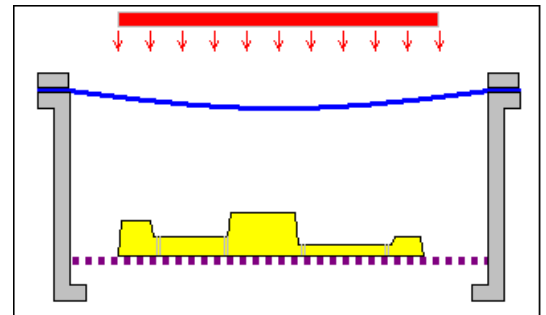

The pattern is then raised up to meet the hot soft plastic.

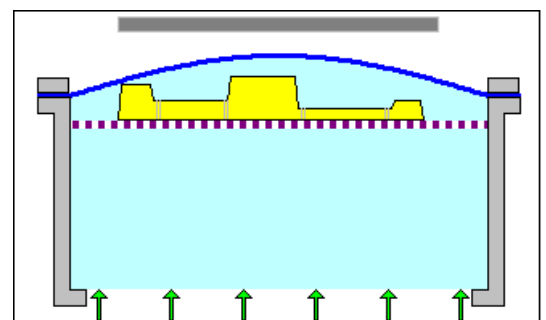

At this stage the air has been sucked out from beneath the plastic pulling it onto the pattern.

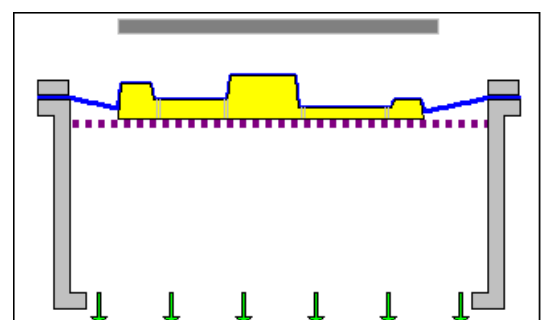

The final stage is to remove the pattern from the plastic leaving the finished article.

