

Greenfaulds High School Technical Department



Standard Grade Craft & Design

Knowledge & Understanding In Metal

Metals

All metals in use today are either PURE METALS or ALLOYS. Copper, iron, tin, lead, gold and silver are all examples of PURE METALS which have been mined from the Earth and extracted from the ore using a process called SMELTING.

An ALLOY is a mixture of pure metals or a metal with a substance such as carbon added; examples of alloys are:- **Steel** (Iron & Carbon), **Duralumin** (Aluminium & Copper), **Brass** (Copper & Zinc) & **Bronze** (Copper & Tin).

Metals are usually classified into two main groups; FERROUS metals and NON-FERROUS metals.

Ferrous Metals

This category of metals contain iron and are usually magnetic; examples of such are Cast Iron, Mild Steel, High Carbon Steel, etc.

Non-Ferrous Metals

As the name implies (NON), this category of metal does not contain iron and is usually non-magnetic; examples are, Aluminium, Copper, Brass, Duralumin, Lead, Gold, Silver, etc.

Form of Supply

Most metals are available in a wide variety of shapes and sizes and are usually described by their cross-section. i.e. what they look like when they have been sawn through.

The following cross sections are typical examples of how metals are supplied to the school workshop.

Round Rod



Sheet



Squares



Round Tube

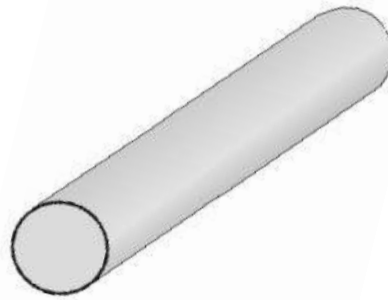

Flats



Square Tube

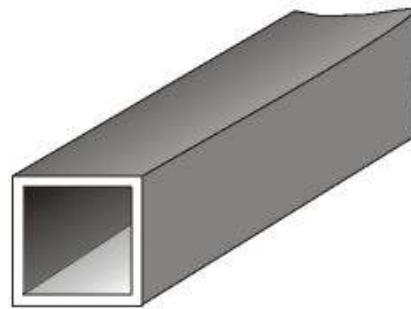

Hexagonal Bar

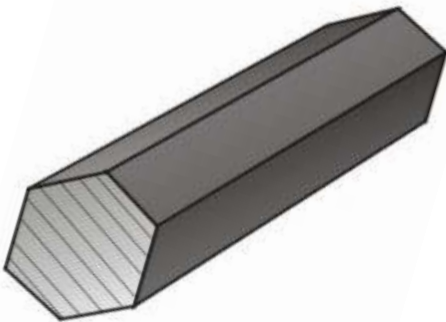

Rectangular Tube



Octagonal Bar



Angle



Metal Working Tools

Marking Out Tools

Engineers Square

An Engineers Square is similar to the Try Square except it is smaller and made of metal. It is used to check that the edges of the plastic or metal are square or to scribe lines at **Right Angles** to an edge.

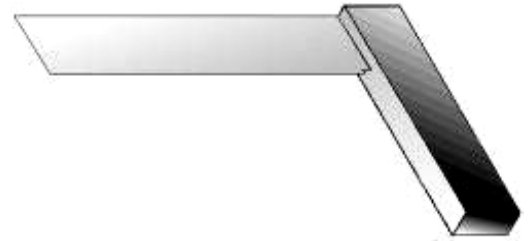

The Centre Punch

Before metal can be drilled with a twist drill the surface must be firstly punched using the Centre Punch. The reason for this is to ensure the drill does not slip on the surface.



Scriber

The scriber is a tool which is used to "SCRIBE" or mark lines on metal.

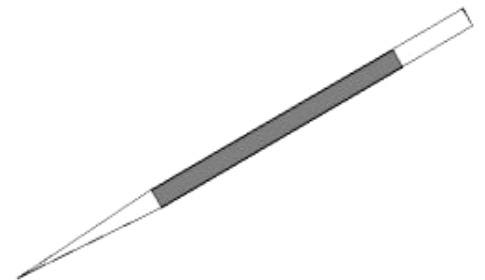

Odd Leg Callipers

These are used to mark out lines on metal **Parallel** to an edge.

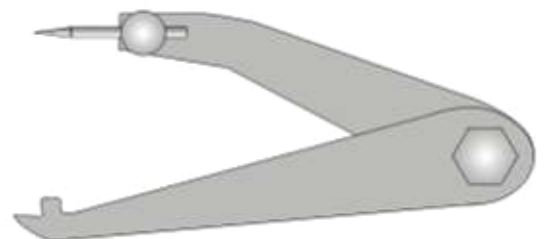

Spring Dividers

These are used to mark out circles and arcs and to step out equal lengths along a line.



Outside Callipers

Outside callipers are used for testing the outside diameters of round bars and thicknesses of sheet metal where it is difficult to use a steel rule.

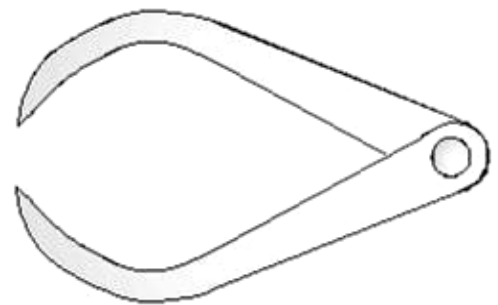

Inside Callipers

Inside callipers are used to are used to test the diameters of holes, the distances between two surfaces where it would be difficult to use a steel rules

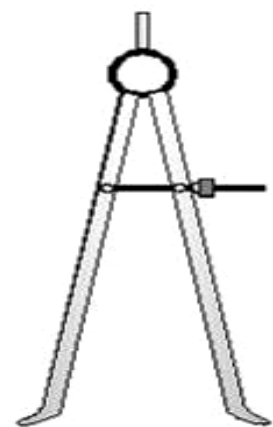

Files

Files are used to shape metal.
They are available in a number of different shapes and degrees of roughness.

Files must not be used without a handle.



Sections of Files

Square

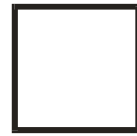

Round

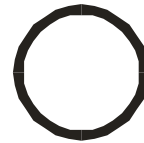

3 Square



Flat



Half Round



Cross filing

In this type of filing the file is moved across the work piece using the full length of the blade. This method of filing is used for removal of a lot of material with every stroke applied.

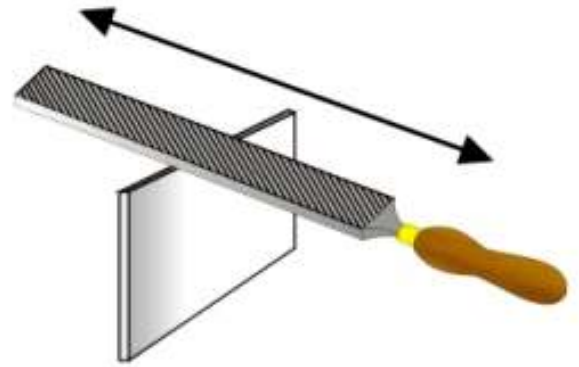

Draw filing

In this method of filing, the file is moved sideways along the work piece and is used to obtain a smooth finish after cross filing. This method does not remove much material.

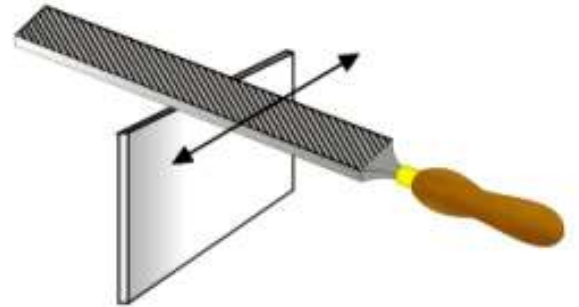

Cleaning the file

Small pieces of plastic can be trapped between the teeth of the file. This is called **PINNING**.

A **FILE CARD** can be used to clear the file of the excess material. The file card looks very similar to a wire brush except the teeth are very short.

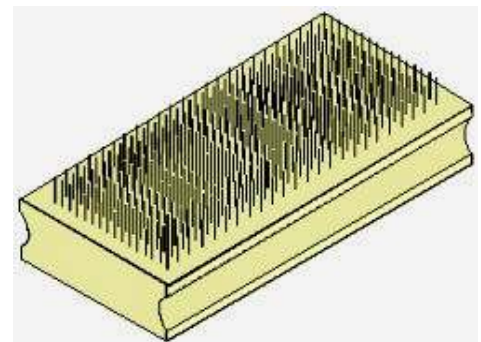

Hacksaw

The hacksaw is used for general cutting of metal bar, tubes, etc. The blade is easily removed by slackening or tightening of the front wing nut.



Junior Hacksaw

This type of saw is also used for cutting metal but is used for light work or where a hacksaw is too clumsy.



Raw Hide Mallet

This mallet is used when it is important not to make any marks on the metal



Ball Pein Hammer

This is a general use hammer although the ball end of the hammer is used specifically to round the heads of the snap head rivet.



Portable Electric Drill

These drills are usually available in schools with a maximum chuck capacity of 13mm (i.e. can hold a drill diam. of 13mm maximum)



Hand Drill

The hand drill or WHEEL BRACE is used to hold and turn twist drills up to 8mm in diameter. The chuck has three self centring jaws which securely grip the shank of the drill.



Drills

Drills are manufactured from high speed steel (H.S.S.) or carbon steel and are used for drilling circular holes in metal, plastic or wood. The most common type of drills used are the TWIST DRILLS. These drills have three basic parts, a point, a parallel body and a shank which can be either parallel or tapered.

A countersunk drill is used to countersink holes in wood, metal and plastics to allow the accommodation of a countersunk screw head. As can be seen from the sketch opposite the screw will head sit below the surface of the material.

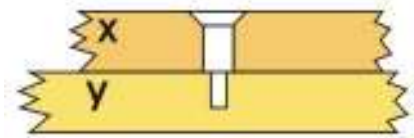

The Pillar Drill

The pillar drill (or Vertical Drill) can either be bench mounted or floor mounted. The chuck (part which holds the twist drill) can hold drills up to 13mm in diameter. The adjustable table which holds the work piece can slide up or down and can be locked at a desirable height.

Safety Check

Before Drilling - ensure the drill is secure with the chuck key removed, eye protection on, guard in position and work piece securely held.



Standard Screw Threads

The screw thread is a very important detail in engineering. It is used to hold parts together. (e.g. bolt & nut) and to transmit power (e.g. vice screw).



Screw Cutting

To achieve an internal screw thread, a hole has to be drilled first and then a tool called a TAP is used to cut a thread within the hole. TAPS are made from high speed steel (HSS). The top of the tap is square which enables the tap to be held securely in a TAP WRENCH, which can be seen below.



Taps are generally available in sets of three and are used in the following order:-

1. Taper Tap
2. Second Tap
3. Plug Tap

When tapping a thread in an internal hole the actual hole drilled must be smaller than the actual overall size of the thread to be cut. An explanation of this is shown in the sketch on the next page.

Tap



| ISO Metric Coarse Pitch Threads | | |
|---------------------------------|---------|-----------|
| Diam. | Tapping | Clearance |
| M2 | 1.6mm | 2.5mm |
| M2.5 | 2.1mm | 3.0mm |
| M3 | 2.5mm | 3.5mm |
| M4 | 3.3mm | 4.5mm |
| M5 | 4.2mm | 5.5mm |
| M6 | 5.0mm | 6.5mm |
| M8 | 6.8mm | 8.5mm |
| M10 | 8.5mm | 10.5mm |
| M12 | 10.2mm | 13.0mm |

Tapping into a smaller diameter hole

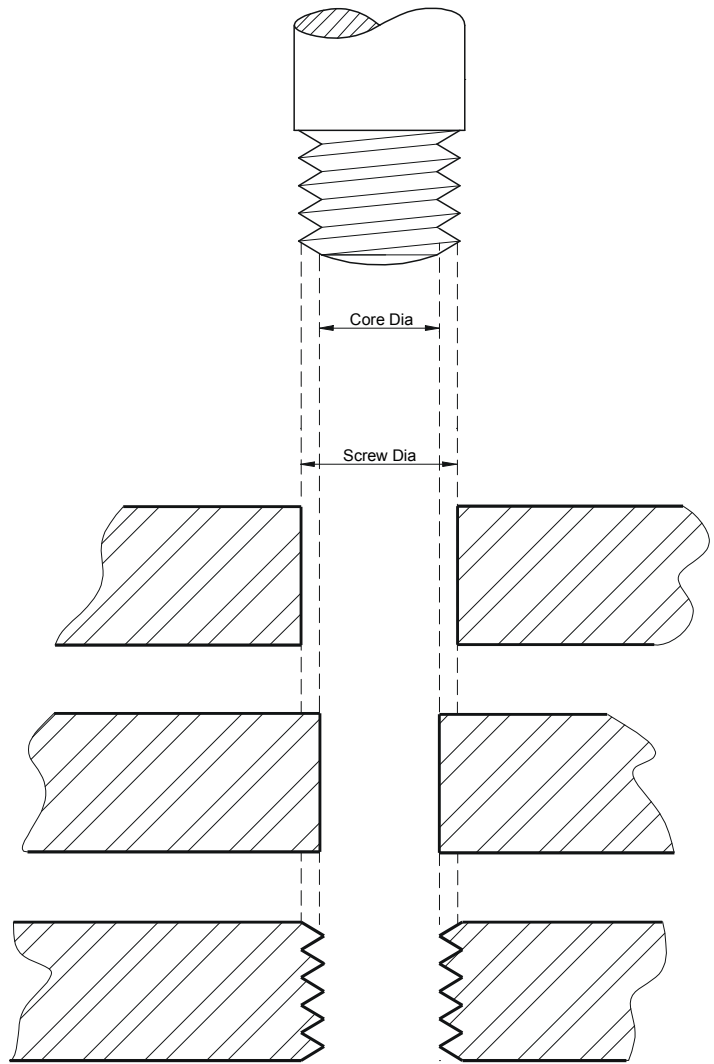
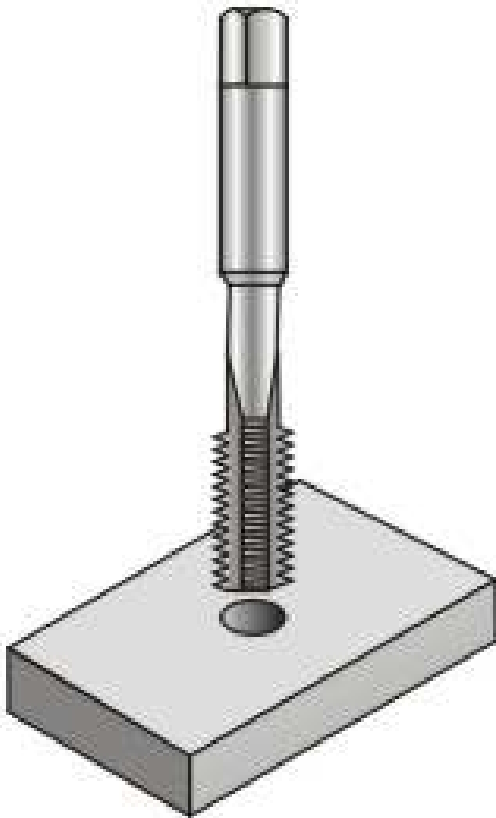

The drawing above shows that if a hole was drilled the same size as the threaded bar, the bar would just fall through. The hole to be drilled must therefore be smaller in diameter so as to allow the TAP to cut the threads.

Remember to use the correct cutting lubricant

External Screw Cutting

In the previous few pages internal screw cutting was explored. External screw cutting will now be investigated. To cut an external thread on a metal rod a tool called a DIE will be used.

Circular Split Die

The picture opposite shows a split die, this is the most common type of die used in the school workshop. These are used for cutting external threads. The die is made from high speed steel (HSS). To assist in starting to cut a thread the split enables the die to be opened slightly.



Die Holder or Stock

The circular split die fits into the die stock with the tapered side of the thread (shown by the writing on the die). The split in the die fits opposite the centre screw to allow the opening and closing of the die. The two screws at the side hold the die in the stock. To ensure the die can start to create a thread on the rod the rod must firstly be tapered at the end.



Riveting

Riveting is the process of joining two or more pieces of metal together permanently. The process uses metal plugs, more commonly known as rivets. To form the joint, the shank of the rivet is passed through a previously drilled hole in the components to be joined, is cut to size and then spread or shaped, thus preventing the parts from separating.

Rivets are classified by the shape of the head, their diameter and length. Common rivet head shapes are round (or snap), countersunk, pan and flat. Other types of rivet found in the workshop are BIFURCATED and POP rivets. In general the type of work at hand will determine the type of rivet to use.

Rivets are made in most types of metal; e.g. mild steel, copper, stainless steel, brass, aluminium. When using a rivet always ensure that the rivet being used is the same material as the metals being joined or it will result in aggravated corrosion at the rivet site.

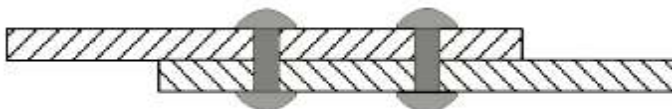

The sketch above shows two sheets of metal riveted together using a snap head rivet in conjunction with the ball pein hammer and rivet and snap set.



Snap Head



Flat Head



Countersink Rivet

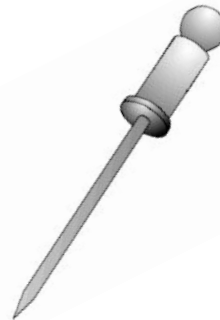

Pop Rivet



Rivet Snap & Set

Heat Treatment

When a metal is cold worked, i.e. when it is cut, beaten, hammered, bent, twisted or shaped, etc. at normal room temperature, tremendous internal forces are set up within its grain structure and the metal becomes extremely hard and liable to split. The term 'heat treatment' is applied to metals that undergo some form of heating process in order to change their properties. Generally, any heating process carried out on a solid metal is referred to as heat treatment. Heat treatments involve processes such as annealing, normalising, forging, hardening, tempering, etc.



Anvil

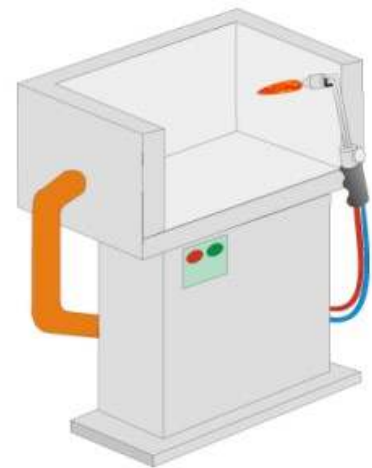

Forge

Annealing

This process makes the metal as soft as possible to relieve the internal stresses, and make it easier to shape. The annealing process generally involves heating up to a certain temperature and allowing to cool, either in the air or in water depending on the material being annealed.

Hardening

To enable carbon steel (i.e. tool steel) to be used for the wide variety of tools and articles that are necessary in the school workshop and in industry it must first be hardened, then tempered.

Taking a high carbon screwdriver blade for example, this is HARDENED by heating it slowly to a dull cherry colour and then quenching it in oil or tepid water. When this part of the process has been carried out it is unusable. Although it is very hard it is also very brittle (i.e. it can break very easily). To make the hardened steel usable it must now be TEMPERED, i.e. given properties such as toughness, elasticity, strength.

Tempering

This process involves heating the metal to approximately 300° C and then immediately quenching it in water. As the metal is being heated it changes colour starting with a pale straw to dark straw to reddish brown to purple then dark blue. It is when it reaches a dark blue colour it is at 300° C. These colours are known as TEMPERING COLOURS.

Tongs

When heat treating metals the metal gets extremely hot and therefore great care must be taken when working with it. The tool used to hold the metal being worked is called tongs. These come in a number of different shapes to suit the material being worked.



Case Hardening

Mild steel cannot be hardened and tempered as its carbon content is too low. What can be done is to provide it with a hard outer case. In this process the metal is heated to a bright red heat and then rolled in a rich carbon powder. The carbon is absorbed into the skin of the metal thus making it very hard on the outer skin. This type of metal is ideal for components such as gear wheels which require to be hard wearing.

Welding

Welding is the process of joining two pieces of metal together using very high heat and an additional filler metal. The filler metal used must be the same type of metal being permanently joined.

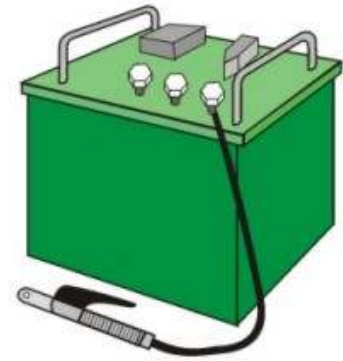

Electric Welding Machine

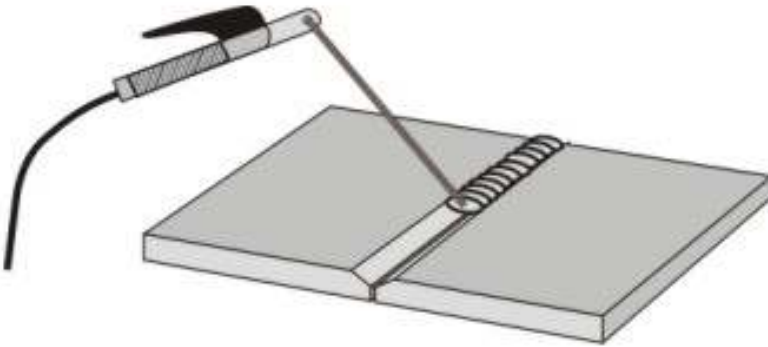

Soldering

Two plates being welded together

Soldering is the process of permanently joining two pieces of metal together using a mixture of tin and lead. Mixing these two metals reduces the overall melting temperature enough to melt the solder using a soldering iron (a heated piece of metal attached to a handle)



Brazing

This process is very similar to soldering in that it uses an alloy heated to its melting temperature to join two pieces of metal together. When Brazing, the filler metal used is called BRAZING SOLDER, which is an alloy of copper and zinc (BRASS). The heat is generated by the use of a blow torch

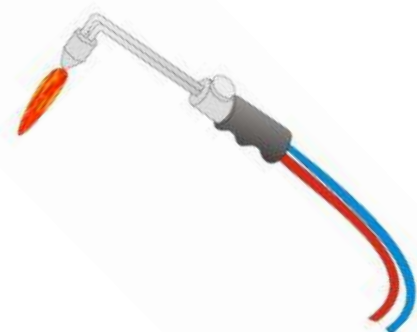

Resistance Spot Welding

Resistance spot welding, usually referred to as SPOT WELDING, is the most widely used of this type of welding. As shown in the sketch opposite the overlapping work is positioned between copper electrodes which have reduced area tips to produce welds that are usually from about 1.6mm to 12.5mm in diameter. After the electrodes are closed onto the work piece a high electric current is passed through these points which fuses (melts) the two pieces of metal together.



Plastic Dip Coating

If a ferrous metal is left in the atmosphere for a length of time it will rust. In order to prevent this from occurring a barrier has to be placed between the metal and the atmosphere. One method of doing this is protecting the metal with a plastic coating.

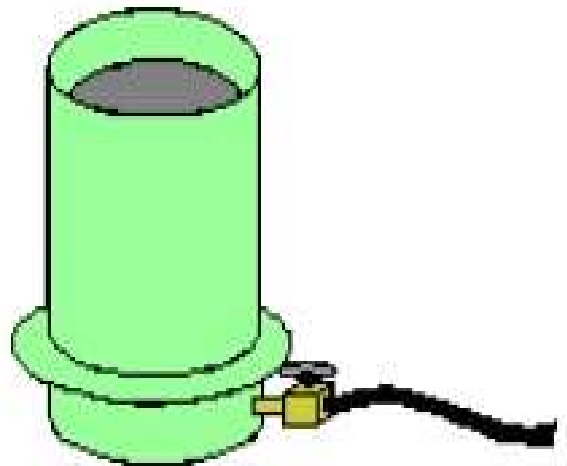

Fluidiser

A plastic coating is applied in the following way:-

1. Thoroughly clean and degrease the metal.
2. Heat the metal to 180° degree C in an oven.
3. Dip the metal into the fluidised plastics powder for a few seconds.
4. Return it to the oven to fuse the coating to a smooth glass finish. Leave to cool.

Metal Lathe

The purpose of a metal lathe is to shape metal bar into various desired shapes. A typical example is the nut & bolt assembly seen earlier in this booklet. The work piece (metal bar) is secured to a rotating three jaw chuck. The tools which are made from High Speed Steel (HSS) are secured in the tool post. An electric motor spins the work piece to which the cutting tools are then brought into contact with the metal bar.

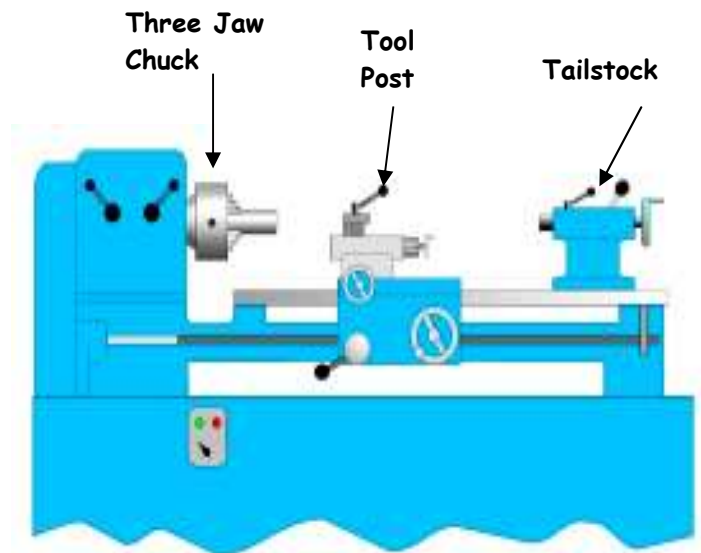

Work piece secured in **THREE JAW CHUCK**

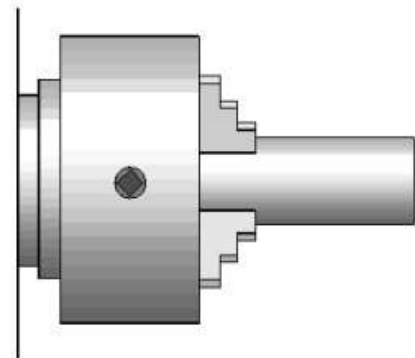

Facing Off

Before starting to shape the metal bar it is essential to face off the end of the bar. This basically means to make the end of the bar perfectly square to the sides of the bar.

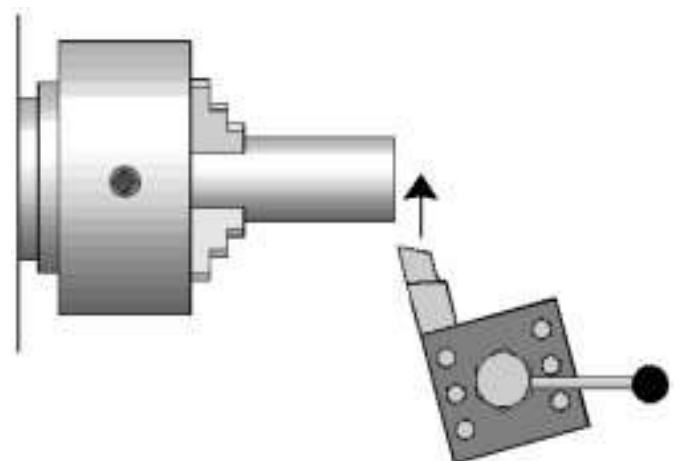

Taper Turning

This is where the tool moves along the bar at an angle moving further away from the centre axis of the bar.

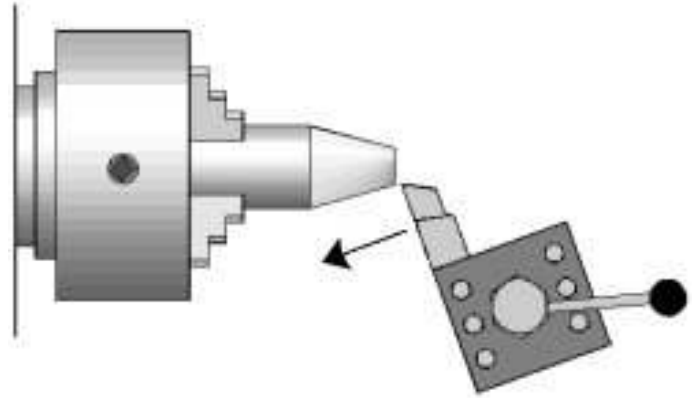

Parallel Turning

This technique moves the tool parallel to the centre axis of the bar as can be seen from the drawing.

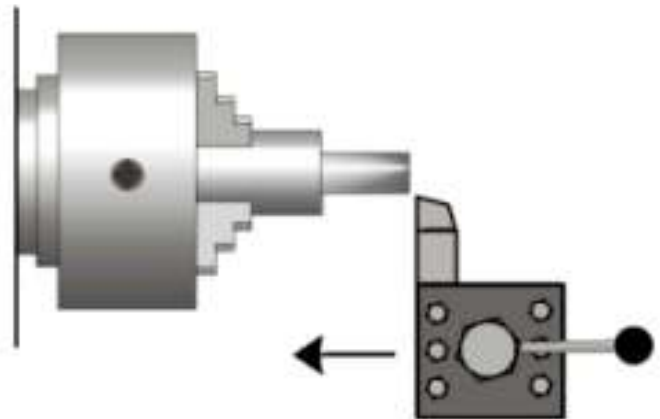

Parting Off

When all turning work has been completed the final task is to "Part Off" (remove the turned piece from the bar secured in the three jaw chuck)

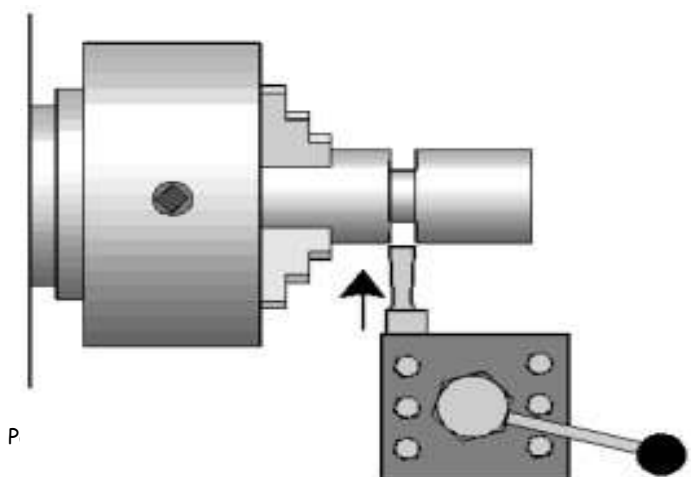

Knurling Tool

This tool is used to “press”, NOT cut a straight or diamond pattern into the metal. The process is usually done to provide a hand grip.



Knurled Bar

Shown opposite is a bar which has been “knurled” with a diamond pattern.



Slocombe or Centre Drill

This is a drill and countersink combined. it is used to drill a hole in one end of a piece of bar so as to accommodate the revolving centre.



Revolving Centre

The revolving centre is secured in the tailstock. The bar to be turned is secured at one end by the chuck and held in place at the other end using the revolving centre. The revolving centre allows the bar to rotate freely allowing turning between centres.

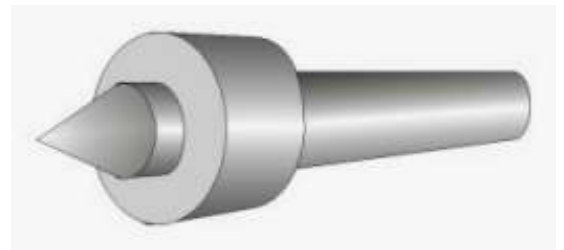

Shown below are commonly used metal lathe cutting tools.

Parting Tool

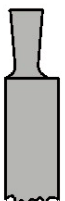

Round Nose

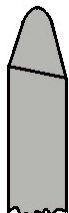

RH Knife



LH Knife



Sand Casting (Moulding)

Sand casting is the process of making metal shapes (components) using pre-shaped objects and sand. A typical example of an object which has been cast is the Engineers vice which can be found on the workbench. This tool will have been cast in two separate castings. The bottom part of the casting unit which is called a **DRAG** is called so because of the fact that the **PATTERN** is dragged from the sand. The top half of the casting unit is called the **COPE**.

Stage 1

The **COPE** and **DRAG** are both filled with wet sand. The pattern (mould) is then pressed into the sand until flush with the surface. As can be seen from the drawing the cope is then placed on top of the drag. Sprue pins are then pushed through the sand to produce a **RUNNER** and a **RISER**. The runner will be the channel in which the molten metal will be poured into the mould.

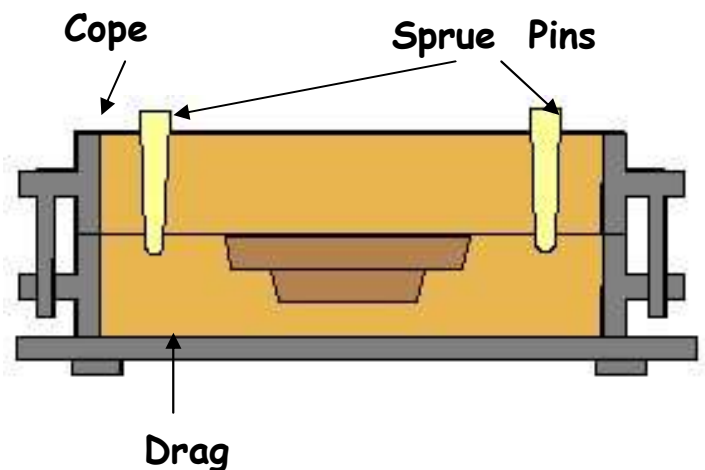

Stage 2

At this stage the wooden pattern has been removed and the riser and runner which were created by the sprue pins have been extended into the space left by the pattern. This will allow molten metal to flow through into the mould.

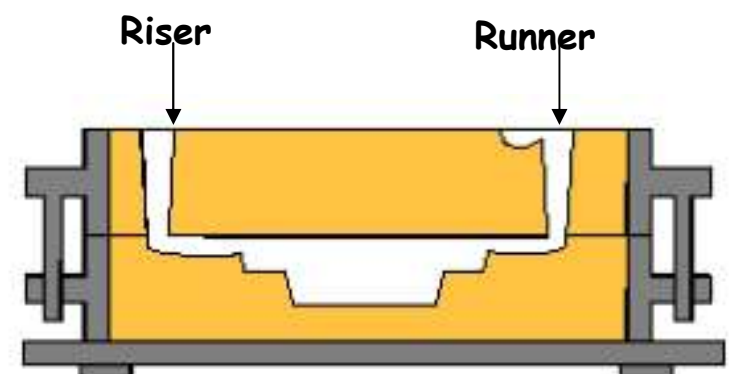

Stage 3

This shows a cross section (cut through the middle) of the pattern and runners. Very narrow holes can be seen, this allows excess air and moisture to escape thus allowing the metal to fill fully all available space in the pattern.

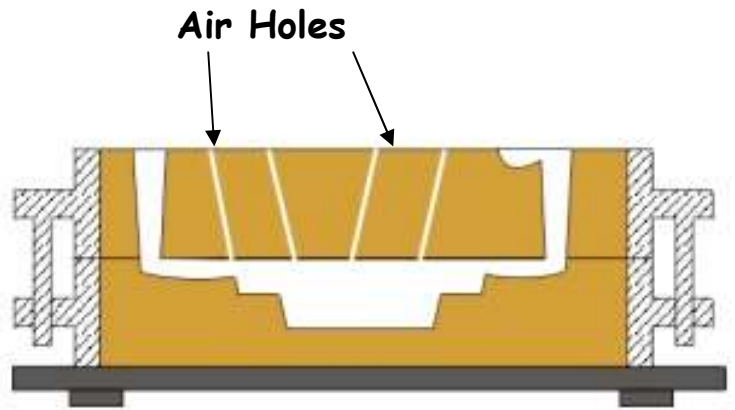

Stage 4

The final stage in the process is to pour the molten metal into the runner. The air which occupies the pattern space is forced out of the riser on the other side. The finished mould is then removed from the sand. The mould will also have extensions attached at this stage in the form of a runner and riser. These will simply be cut off and recycled.

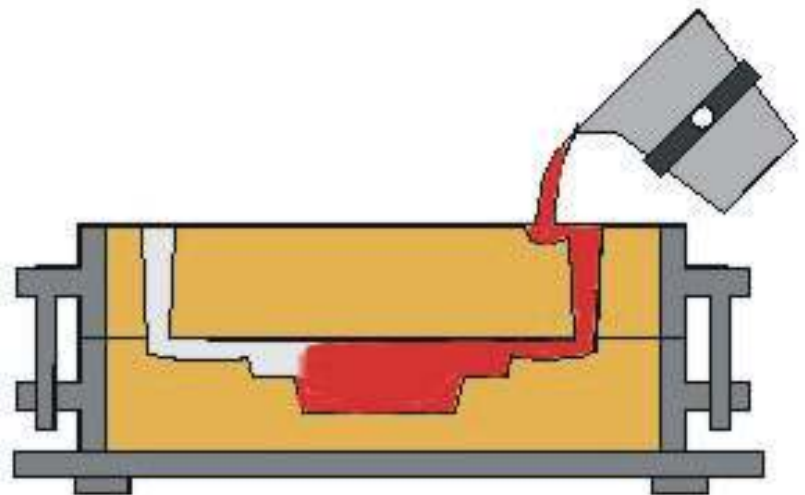

Finished Article

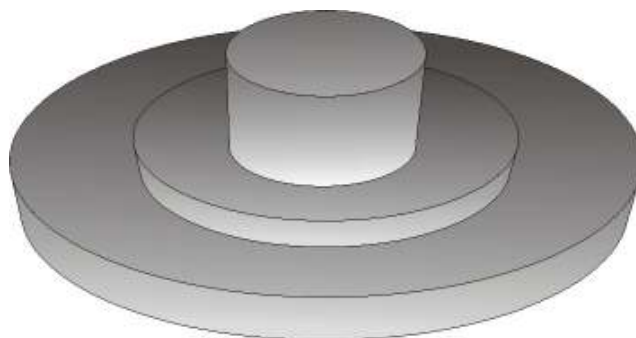

Micrometer

This tool is used to measure sizes of great accuracy. The most commonly used micrometers can measure to one hundredth of a mm. The micrometer is generally used for measuring external sizes.



Vernier Callipers

The vernier callipers are also used for measuring very accurate sizes except the vernier calliper can measure internal sizes, depths and external sizes.

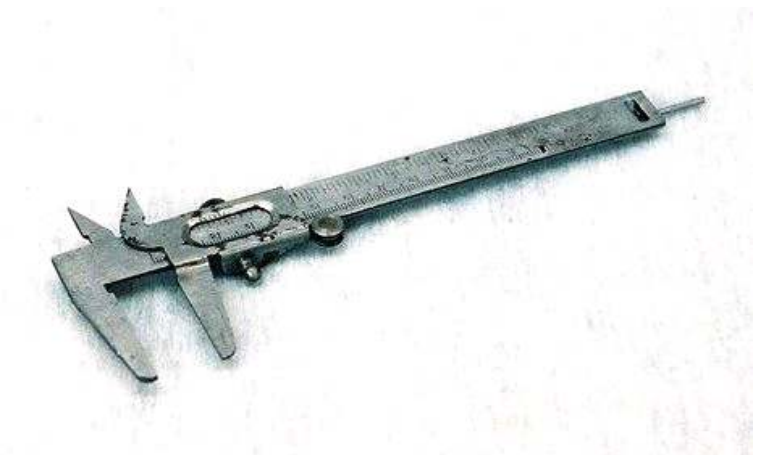

Hand Vice

This is used for holding small and especially irregular shaped parts while drilling, riveting etc.



Machine Vice

This type of vice is used to hold heavier pieces of metal while drilling. The main body of the vice has been CAST in a mould. The handle of the vice has been KNURLED.



Engineer's Vice

The vice is bolted to the bench top so as to ensure the vice does not move while working on it. The vice is used primarily to hold metal while cutting, sawing, filing, etc. are carried out. As with the machine vice the body has also been CAST in two separate pieces.



Toolmaker's Clamp

These are used to hold parts together while marking out, shaping and drilling.

