

X272/13/01

NATIONAL
QUALIFICATIONS
2013

MONDAY, 27 MAY
1.00 PM – 3.30 PM

PHYSICS
ADVANCED HIGHER
(Revised)

Reference may be made to the Physics Data Booklet and the accompanying Relationships Sheet.

Answer **all** questions.

Any necessary data may be found in the Data Sheet on *Page two*.

Care should be taken to give an appropriate number of significant figures in the final answers to calculations.

Square-ruled paper (if used) should be placed inside the front cover of the answer book for return to the Scottish Qualifications Authority.



DATA SHEET
COMMON PHYSICAL QUANTITIES

Quantity	Symbol	Value	Quantity	Symbol	Value
Gravitational acceleration on Earth	g	9.8 m s^{-2}	Mass of electron	m_e	$9.11 \times 10^{-31} \text{ kg}$
Radius of Earth	R_E	$6.4 \times 10^6 \text{ m}$	Charge on electron	e	$-1.60 \times 10^{-19} \text{ C}$
Mass of Earth	M_E	$6.0 \times 10^{24} \text{ kg}$	Mass of neutron	m_n	$1.675 \times 10^{-27} \text{ kg}$
Mass of Moon	M_M	$7.3 \times 10^{22} \text{ kg}$	Mass of proton	m_p	$1.673 \times 10^{-27} \text{ kg}$
Radius of Moon	R_M	$1.7 \times 10^6 \text{ m}$	Mass of alpha particle	m_α	$6.645 \times 10^{-27} \text{ kg}$
Mean Radius of Moon Orbit		$3.84 \times 10^8 \text{ m}$	Charge on alpha particle		$3.20 \times 10^{-19} \text{ C}$
Solar radius		$6.955 \times 10^8 \text{ m}$	Planck's constant	h	$6.63 \times 10^{-34} \text{ J s}$
Mass of Sun		$2.0 \times 10^{30} \text{ kg}$	Permittivity of free space	ϵ_0	$8.85 \times 10^{-12} \text{ F m}^{-1}$
1 AU		$1.5 \times 10^{11} \text{ m}$	Permeability of free space	μ_0	$4\pi \times 10^{-7} \text{ H m}^{-1}$
Stefan-Boltzmann constant	σ	$5.67 \times 10^{-8} \text{ W m}^{-2} \text{ K}^{-4}$	Speed of light in vacuum	c	$3.0 \times 10^8 \text{ m s}^{-1}$
Universal constant of gravitation	G	$6.67 \times 10^{-11} \text{ m}^3 \text{ kg}^{-1} \text{ s}^{-2}$	Speed of sound in air	v	$3.4 \times 10^2 \text{ m s}^{-1}$

REFRACTIVE INDICES

The refractive indices refer to sodium light of wavelength 589 nm and to substances at a temperature of 273 K.

Substance	Refractive index	Substance	Refractive index
Diamond	2.42	Glycerol	1.47
Glass	1.51	Water	1.33
Ice	1.31	Air	1.00
Perspex	1.49	Magnesium Fluoride	1.38

SPECTRAL LINES

Element	Wavelength/nm	Colour	Element	Wavelength/nm	Colour
Hydrogen	656	Red	Cadmium	644	Red
	486	Blue-green		509	Green
	434	Blue-violet		480	Blue
	410	Violet	<i>Lasers</i>		
	397	Ultraviolet	<i>Element</i>	<i>Wavelength/nm</i>	<i>Colour</i>
	389	Ultraviolet	Carbon dioxide	9550 } 10590 }	Infrared
Sodium	589	Yellow	Helium-neon	633	Red

PROPERTIES OF SELECTED MATERIALS

Substance	Density/ kg m^{-3}	Melting Point/ K	Boiling Point/K	Specific Heat Capacity/ $\text{J kg}^{-1} \text{ K}^{-1}$	Specific Latent Heat of Fusion/ J kg^{-1}	Specific Latent Heat of Vaporisation/ J kg^{-1}
Aluminium	2.70×10^3	933	2623	9.02×10^2	3.95×10^5
Copper	8.96×10^3	1357	2853	3.86×10^2	2.05×10^5
Glass	2.60×10^3	1400	6.70×10^2
Ice	9.20×10^2	273	2.10×10^3	3.34×10^5
Glycerol	1.26×10^3	291	563	2.43×10^3	1.81×10^5	8.30×10^5
Methanol	7.91×10^2	175	338	2.52×10^3	9.9×10^4	1.12×10^6
Sea Water	1.02×10^3	264	377	3.93×10^3
Water	1.00×10^3	273	373	4.19×10^3	3.34×10^5	2.26×10^6
Air	1.29
Hydrogen	9.0×10^{-2}	14	20	1.43×10^4	4.50×10^5
Nitrogen	1.25	63	77	1.04×10^3	2.00×10^5
Oxygen	1.43	55	90	9.18×10^2	2.40×10^4

The gas densities refer to a temperature of 273 K and a pressure of $1.01 \times 10^5 \text{ Pa}$.

1. A stunt driver is attempting to “loop the loop” in a car as shown in Figure 1. Before entering the loop the car accelerates along a horizontal track.

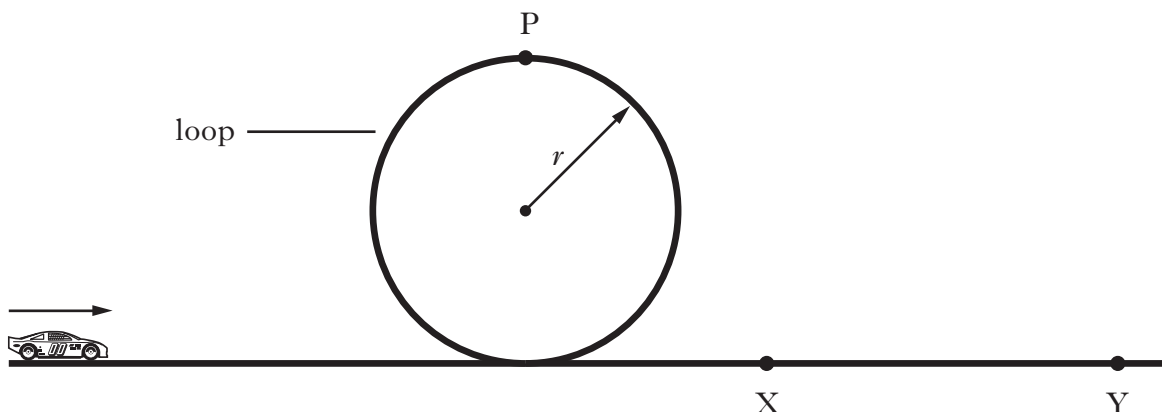

Figure 1

The radius r of the circular loop is 6.2 m.

The total mass of the car and driver is 870 kg.

- (a) Show that the car must have a minimum speed of 7.8 m s^{-1} at point P to avoid losing contact with the track. 2
- (b) During one attempt the car is moving at a speed of 9.0 m s^{-1} at point P.
- (i) Draw a labelled diagram showing the vertical forces acting on the car at point P. 1
- (ii) Calculate the size of each force. 3
- (c) When the car exits the loop the driver starts braking at point X. For one particular run the displacement of the car from point X **until the car comes to rest** at point Y is given by the equation

$$s = 9.1t - 3.2t^2$$

Sketch a graph to show how the displacement of the car varies with time between points X and Y.

Numerical values are required on both axes. 3

(9)

[Turn over

2. The entrance to a building is through a revolving system consisting of 4 doors that rotate around a central axis as shown in Figure 2A.



Figure 2A

The moment of inertia of the system about the axis of rotation is 54 kg m^2 . When it rotates a constant frictional torque of 25 N m acts on the system.

- (a) The system is initially stationary. On entering the building a person exerts a constant force F perpendicular to a door at a distance of 1.2 m from the axis of rotation as shown in Figure 2B.

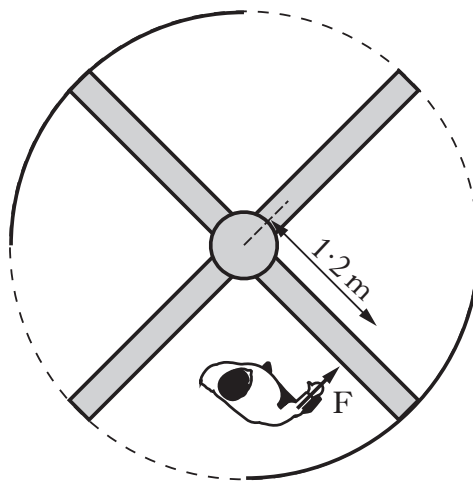

Figure 2B

The angular acceleration of the system is 2.4 rad s^{-2} .

- (i) Calculate the magnitude of the applied force F . 3
- (ii) The applied force is removed and the system comes to rest in 3.6 s . Calculate the angular displacement of the door during this time. 3

2. (continued)

- (b) On exiting the building the person exerts the same magnitude of force F on a door at the same distance from the axis of rotation.

The force is now applied as shown in Figure 2C.

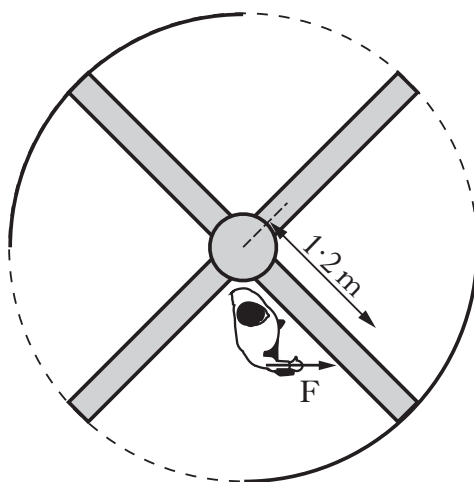

Figure 2C

How does the angular acceleration of the door system compare to that given in part (a)?

Justify your answer.

2

(8)

[Turn over

3. On a trip to a theme park, a student described what happened in the fairground spinner shown in Figure 3.

“You get thrown outwards by centrifugal force – you can feel it – it pushes you into the wall.”



Figure 3

Use your knowledge of physics to discuss this statement.

(3)

4. (a) The world lines for three objects A, B and C are shown in Figure 4A.

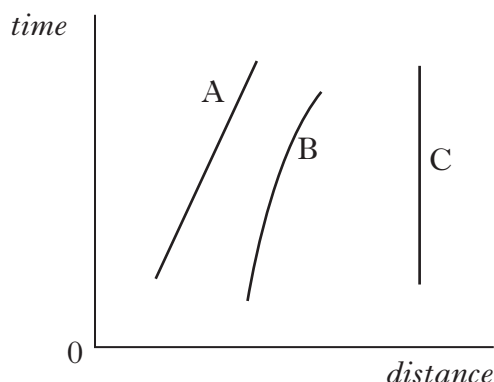

Figure 4A

To which of these objects does the General Theory of Relativity apply? Explain your choice.

2

- (b) A rocket ship is accelerating through space. Clocks P and Q are at opposite ends of the ship as shown in Figure 4B. An astronaut inside the rocket ship is beside clock P and can also observe clock Q.

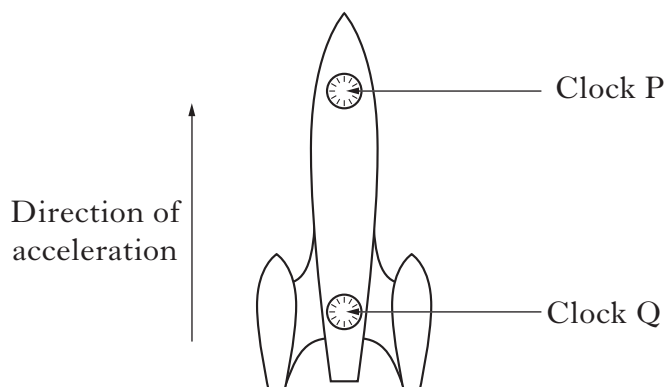

Figure 4B

What does the astronaut observe about the passage of time for these clocks? Justify your answer.

2

- (c) Part of an astronaut's training is to experience the effect of "weightlessness". This can be achieved inside an aircraft that follows a path as shown in Figure 4C.

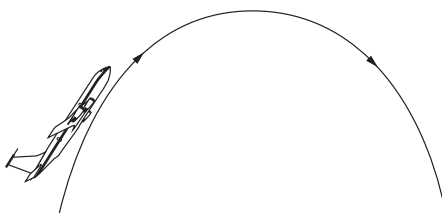

Figure 4C

Use the equivalence principle to explain how this "weightlessness" is achieved.

2

(6)

5. Hertzsprung-Russell (H-R) diagrams are widely used by physicists and astronomers to categorise stars. Figure 5A shows a simplified H-R diagram.

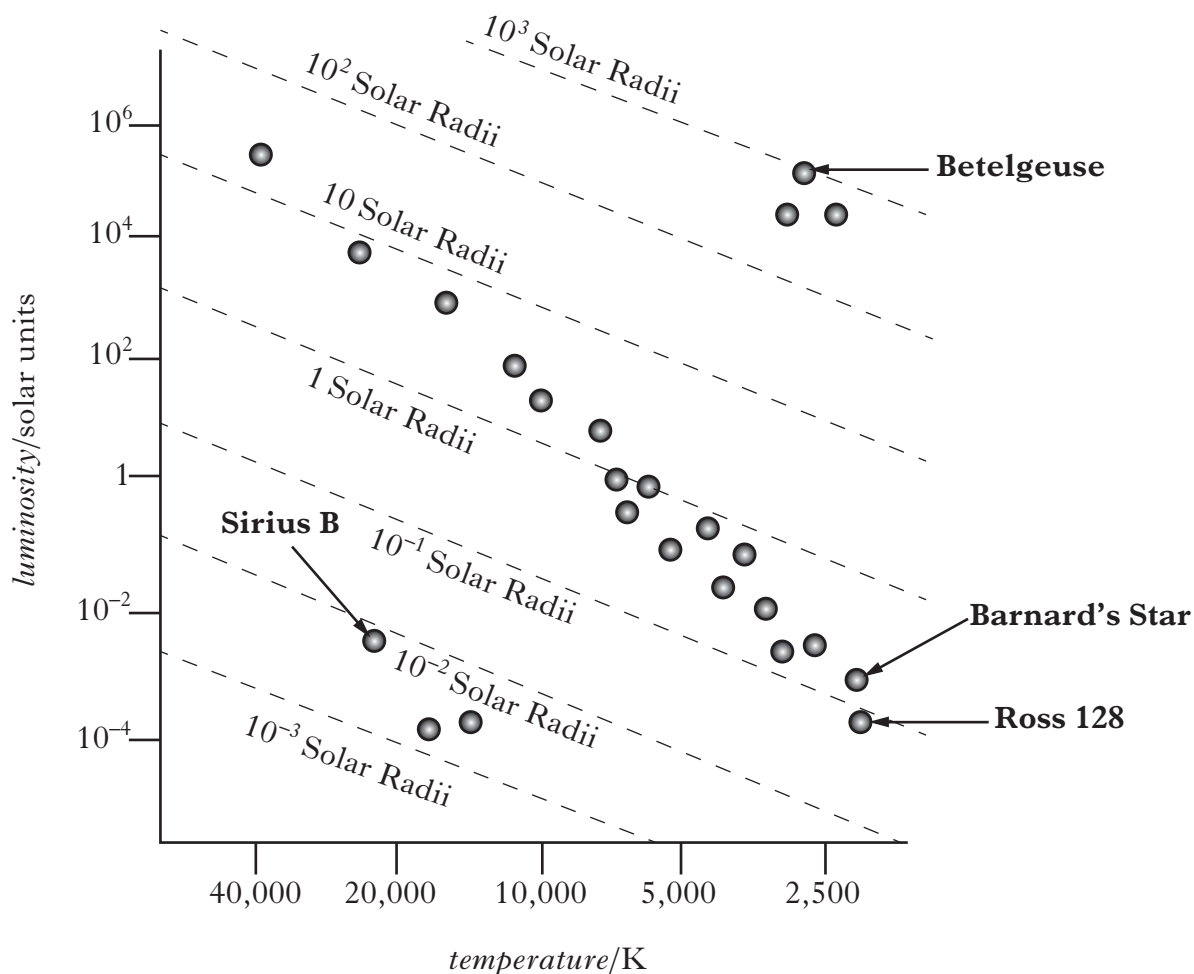

Figure 5A

- (a) What class of star is Sirius B? 1
- (b) Estimate the radius in metres of Betelgeuse. 2
- (c) Ross 128 and Barnard's Star have a similar temperature but Barnard's Star has a slightly greater luminosity. What other information does this tell you about the two stars? 1

5. (continued)

Marks

- (d) During the life cycle of the Sun its position in the H-R diagram is expected to change as shown by the arrowed line in Figure 5B.

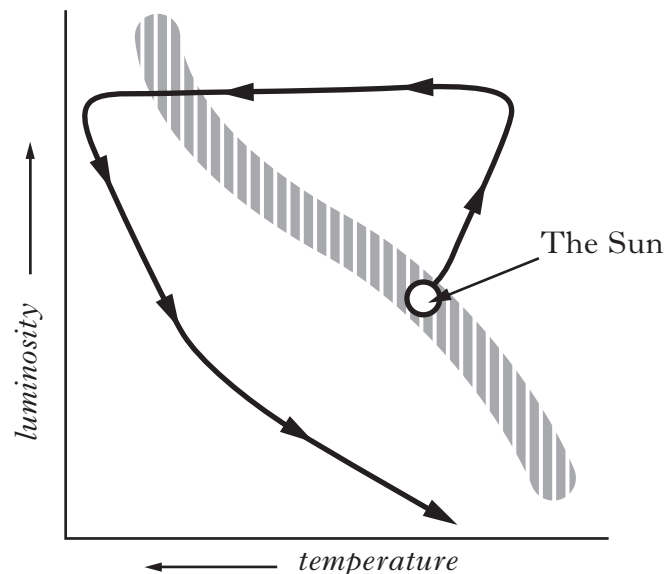

Figure 5B

Describe the changes that occur to the Sun during its expected life cycle.

3

- (e) Hydrogen fusion in a star is a result of a proton-proton chain. The process eventually results in the production of a helium-4 nucleus.

(i) Show that the percentage loss of mass from four protons to one helium-4 nucleus is 0.7%.

2

(ii) The luminosity of the Sun is 3.8×10^{26} W. Using Einstein's energy equation, show that the mass of hydrogen lost per second in the Sun is 4.2×10^9 kg.

1

(iii) Estimate the lifetime of the Sun in seconds. Assume the mass of hydrogen in the Sun to be the same as the mass of the Sun.

1

- (f) The “no greenhouse” temperature of a planet is the average surface temperature of a planet in the absence of any greenhouse effect. The “no greenhouse” temperature of a planet in kelvin is given by

$$T = 280 \left(\frac{(1 - \text{reflectivity})}{d^2} \right)^{\frac{1}{4}}$$

where d is the distance from the Sun in astronomical units (AU).

The reflectivity is a measure of the percentage of energy reflected from the surface, 1 represents 100% reflectivity and 0 represents no reflectivity.

Mercury has a reflectivity of 0.12 and is 5.8×10^{10} m from the Sun.

Calculate its “no greenhouse” temperature.

2

(13)

6. Detailed observations of sunspots have been obtained by the Royal Greenwich Observatory since 1874. These observations include information on the sizes and positions of sunspots as well as their numbers. The number of sunspots is an indication of solar activity. A graph of the average number of sunspots since 1950 is shown in Figure 6.

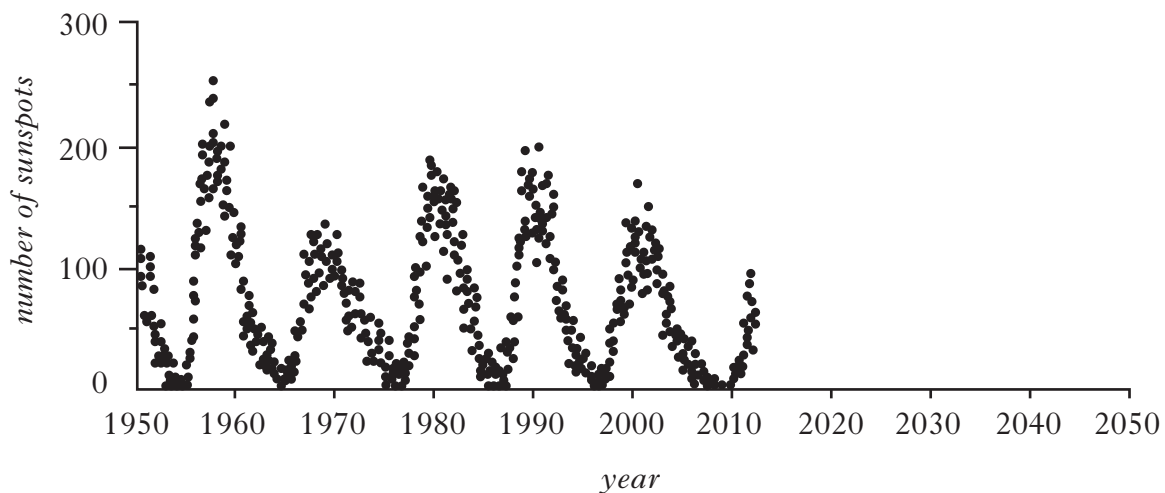

Figure 6

Coronal mass ejections (CME) are one type of solar activity. CMEs are huge magnetic bubbles of plasma that expand away from the Sun at speeds as high as 2000 km s^{-1} . A single CME can carry up to ten million tonnes (10^{10} kg) of plasma away from the Sun.

Use your knowledge of physics to discuss the potential effects that solar activity could have on Earth over the next few years.

(3)

7. A “saucer” swing consists of a bowl shaped seat of mass 1.2 kg suspended by four ropes of negligible mass as shown in Figure 7A.



Figure 7A

When the empty seat is pulled back slightly from its rest position and released its motion approximates to simple harmonic motion.

- (a) Define the term *simple harmonic motion*. 1
- (b) The acceleration-time graph for the seat with no energy loss is shown in Figure 7B.

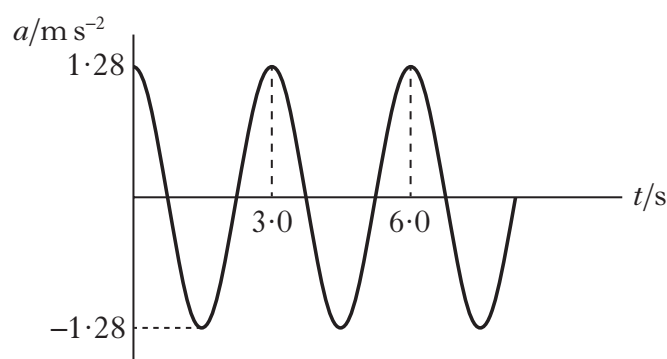

Figure 7B

- (i) Show that the amplitude of the motion is 0.29 m . 3
- (ii) Calculate the velocity of the seat when its displacement is 0.10 m . 2
- (c) Calculate the displacement of the seat when the kinetic energy and potential energy are equal. 3

(9)**[Turn over**

8. High quality *optical flats* made from glass are often used to test components of optical instruments. A high quality optical flat has a very smooth and flat surface.

(a) During the manufacture of an optical flat, the quality of the surface is tested by placing it on top of a high quality flat. This results in a thin air wedge between the flats as shown in Figure 8A.

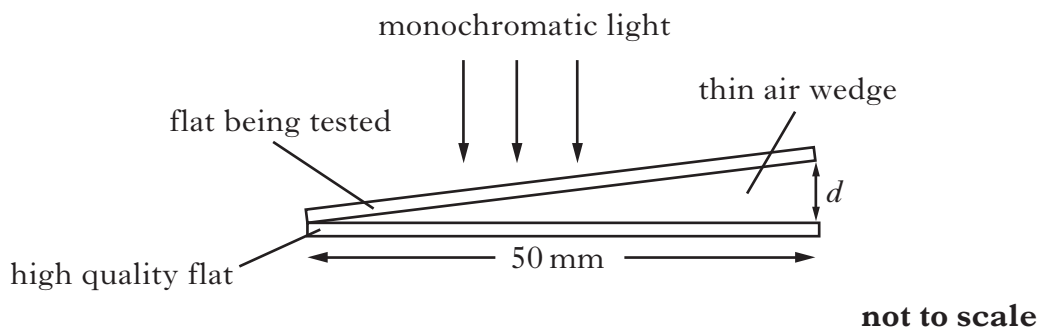

Figure 8A

The thickness d of the air wedge is 6.2×10^{-5} m.

Monochromatic light is used to illuminate the flats from above. When viewed from above using a travelling microscope, a series of interference fringes is observed as shown in Figure 8B.

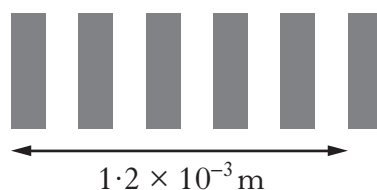

Figure 8B

Calculate the wavelength of the monochromatic light.

3

(b) A second flat is tested using the same method as in part (a). This flat is slightly curved as shown in Figure 8C.



Figure 8C

Draw the fringe pattern observed.

1

8. (continued)

- (c) Good quality optical flats often have a non-reflecting coating of magnesium fluoride applied to the surface as shown in Figure 8D.

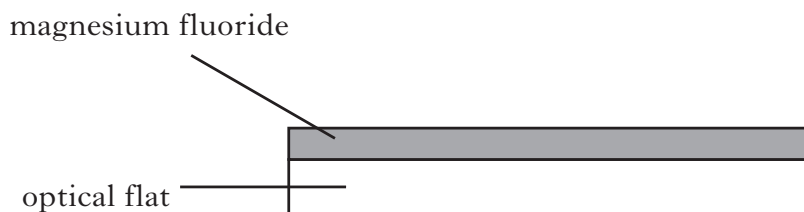

Figure 8D

- (i) With the aid of a diagram explain fully how the coating reduces reflections from the flat for monochromatic light. 2
- (ii) Calculate the minimum thickness of magnesium fluoride required to make the flat non-reflecting for yellow light from a sodium lamp. 2

(8)**[Turn over**

9. A water wave of frequency 2.5 Hz travels from left to right.

Figure 9 represents the displacement y of the water at one instant in time.

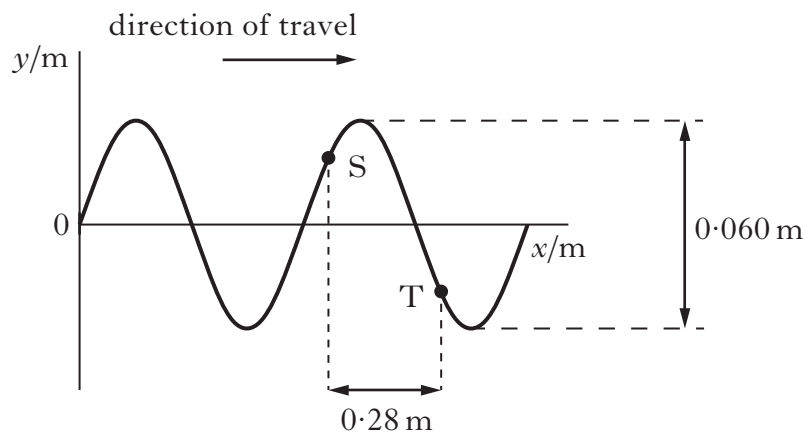

Figure 9

Points S and T are separated by a horizontal distance of 0.28 m.

The phase difference between these two points is 3.5 radians.

- (a) Calculate the wavelength of this wave. 2
- (b) A second wave with double the frequency travels in the same direction through the water. This wave transfers five times the energy of the wave in part (a).
Calculate:
- (i) the speed of this wave; 1
- (ii) the amplitude of this wave. 2
- (5)**

[Turn over for Question 10 on *Page sixteen*

10. The Bohr model of the atom suggests that the angular momentum of an electron orbiting a nucleus is quantised.

A hydrogen atom consists of a single electron orbiting a single proton. Figure 10A shows some of the possible orbits for the electron in a hydrogen atom.

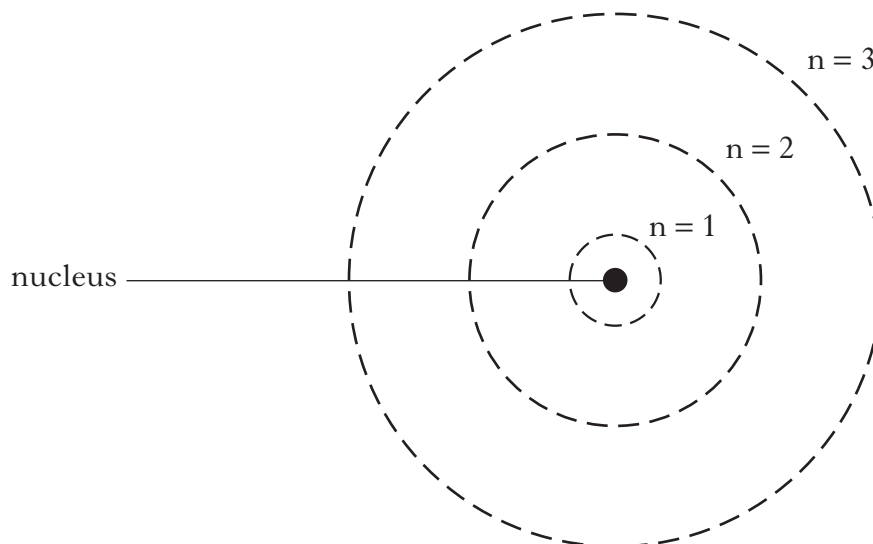

Figure 10A

The table shows the values of the radii for the first three orbits.

<i>Orbit number, n</i>	<i>Orbital radius/10⁻¹⁰ m</i>
1	0.53
2	2.1
3	4.8

- (a) Calculate the speed of the electron in the orbit number 3. 2
- (b) Calculate the de Broglie wavelength associated with this electron. 2
- (c) Some of the limitations of the Bohr model of the atom are addressed by Quantum Mechanics.
- (i) The position of an electron in a hydrogen atom was measured with an uncertainty of 0.15 nm.
Calculate the minimum uncertainty in its momentum. 2

10. (c) (continued)

- (ii) A diagram of electron probability distribution for the hydrogen atom is shown in Figure 10B.

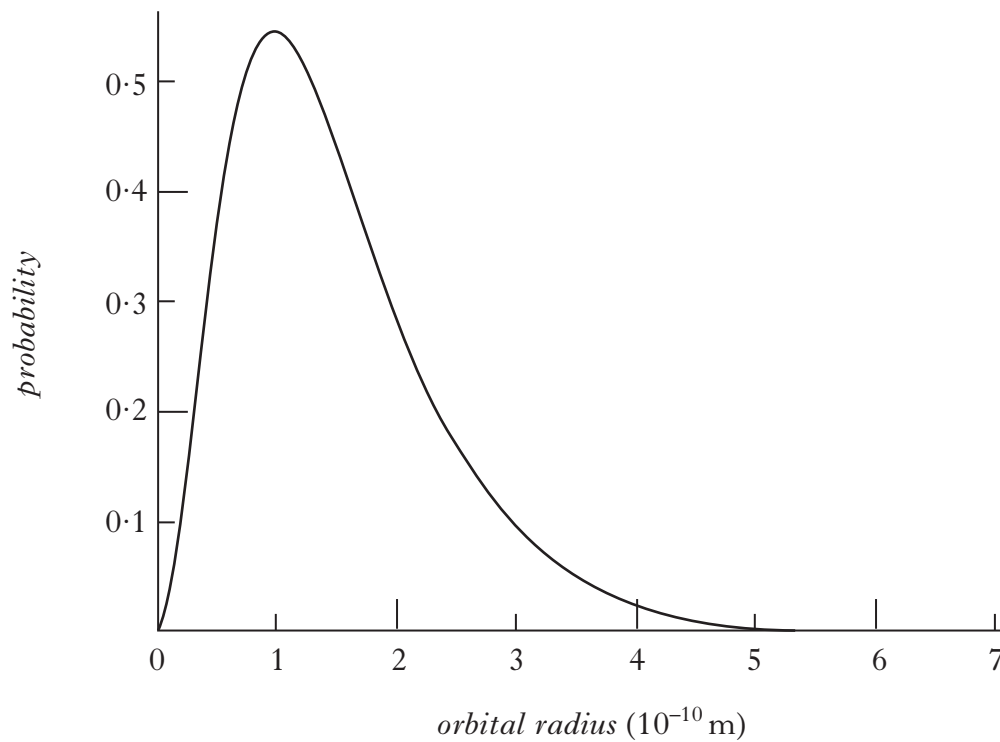

Figure 10B

Comment on the position of the electron in this orbital.

2

(8)

[Turn over

11. In a nuclear power station liquid sodium is used to cool parts of the reactor. An electromagnetic pump keeps the coolant circulating. The sodium enters a perpendicular magnetic field and an electric current, I , passes through it. A force is experienced by the sodium causing it to flow in the direction shown in Figure 11.

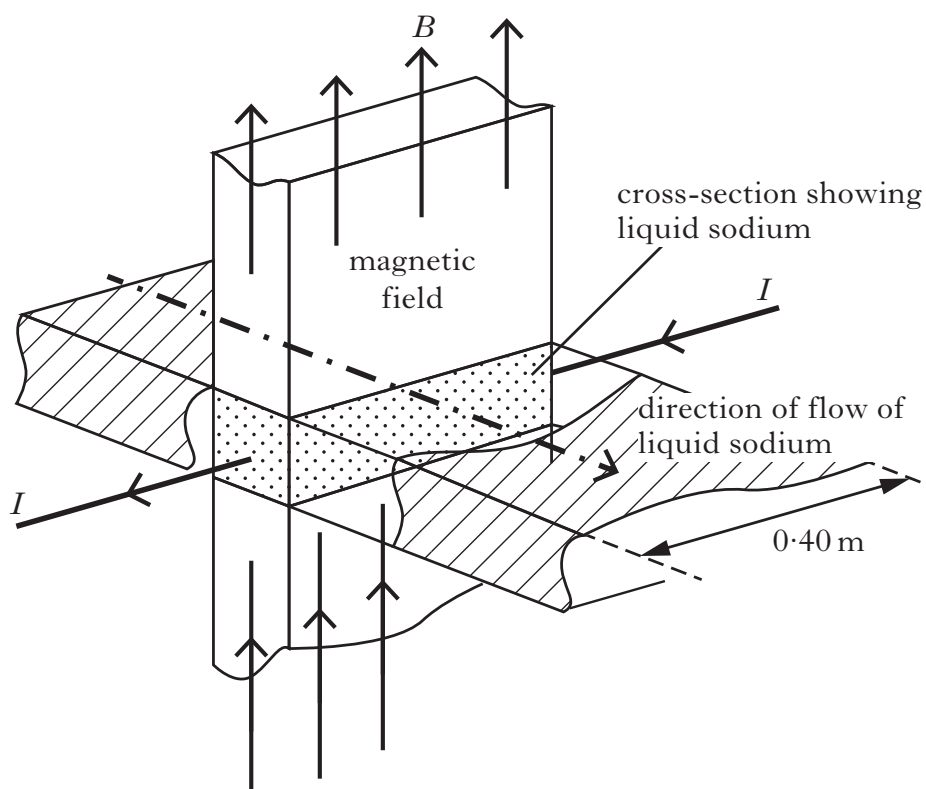

Figure 11

The magnetic induction B is 0.20 T . The current I in the sodium is 2.5 A and is perpendicular to the magnetic field.

- (a) Calculate the force acting on the 0.40 m length of sodium within the magnetic field. 2
- (b) The pump is moved during maintenance and as a result the direction of the magnetic field is changed so that it is no longer perpendicular to the current. What effect does this have on the rate of flow of sodium passing through the pump?
You **must** justify your answer. 2
- (c) An engineer must install a long, straight, current carrying wire close to the pump and is concerned that the magnetic induction produced may interfere with the safe working of the pump.

The wire is 750 mm from the pump and carries a current of 0.60 A .

Show by calculation that the magnetic induction at this distance is negligible. 2

(6)

12. A student is investigating the electrical potential around a point charge Q. Point P is at a distance of (0.65 ± 0.02) m from Q as shown in Figure 12. The potential at point P is (2.1 ± 0.1) V.

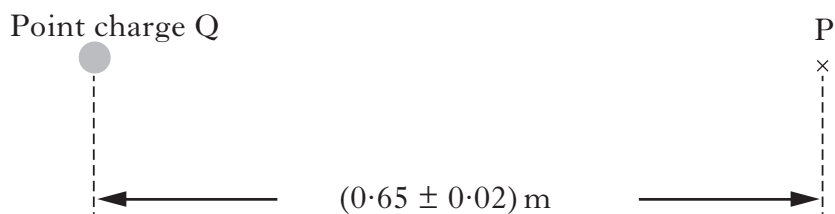

Figure 12

- (a) Calculate the value of the point charge Q. 2
- (b) Calculate the absolute uncertainty in the charge. 2
- (4)**

[Turn over

13. A student is investigating the charging and discharging of a capacitor. The circuit used is shown in Figure 13A. Marks

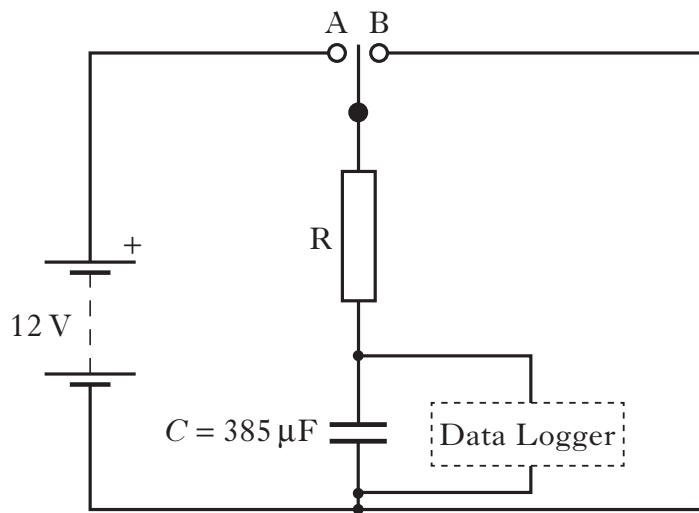

Figure 13A

With the switch in position A, the capacitor charges. To discharge the capacitor, the switch is moved to position B. The data logger monitors the voltage across the capacitor.

The graph in Figure 13B shows how the voltage across the capacitor changes during discharge.

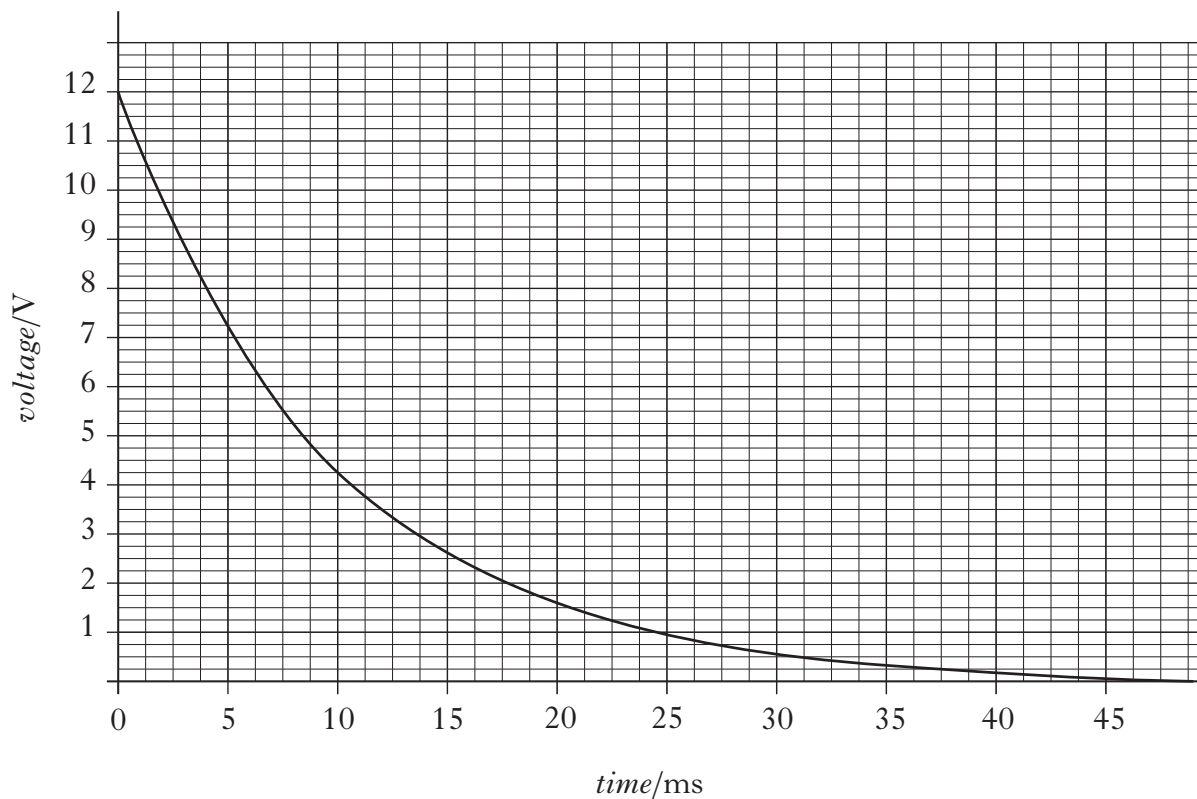

Figure 13B

- (a) Determine the time constant from the graph. 2
- (b) Calculate the resistance of resistor R. 2

(4)

14. A 0.40 H inductor of negligible resistance is connected in a circuit as shown in Figure 14. Switch S is initially open.

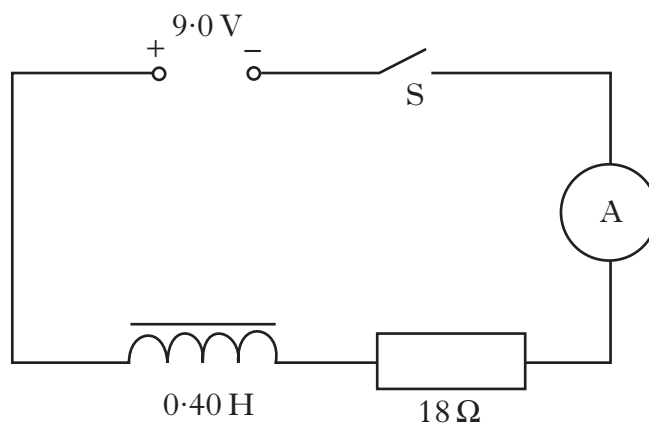

Figure 14

- (a) (i) Sketch a graph of current against time after the switch S is closed. Numerical values are required on the current axis. 2
- (ii) Explain fully the shape of the graph. 2
- (b) Calculate the initial rate of change of current when switch S is closed. 2
- (6)

[Turn over

15. A student sets up an LC circuit, as shown in Figure 15A.

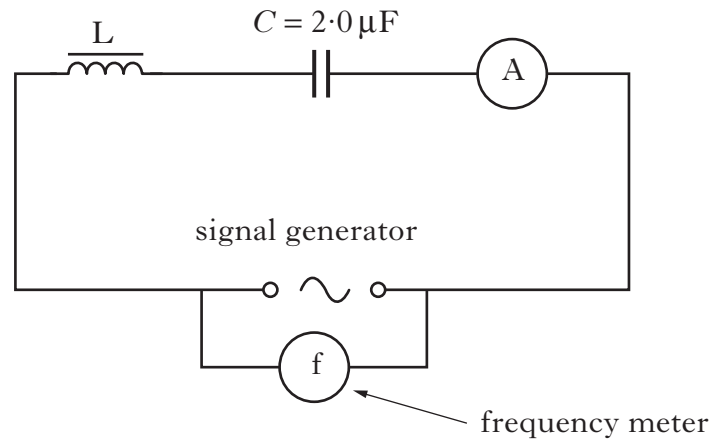

Figure 15A

Maximum current occurs at the resonant frequency f_0 . Resonance occurs when the capacitive reactance equals the inductive reactance. The student varies the supply frequency and records the corresponding current. A graph of current against frequency is shown in Figure 15B.

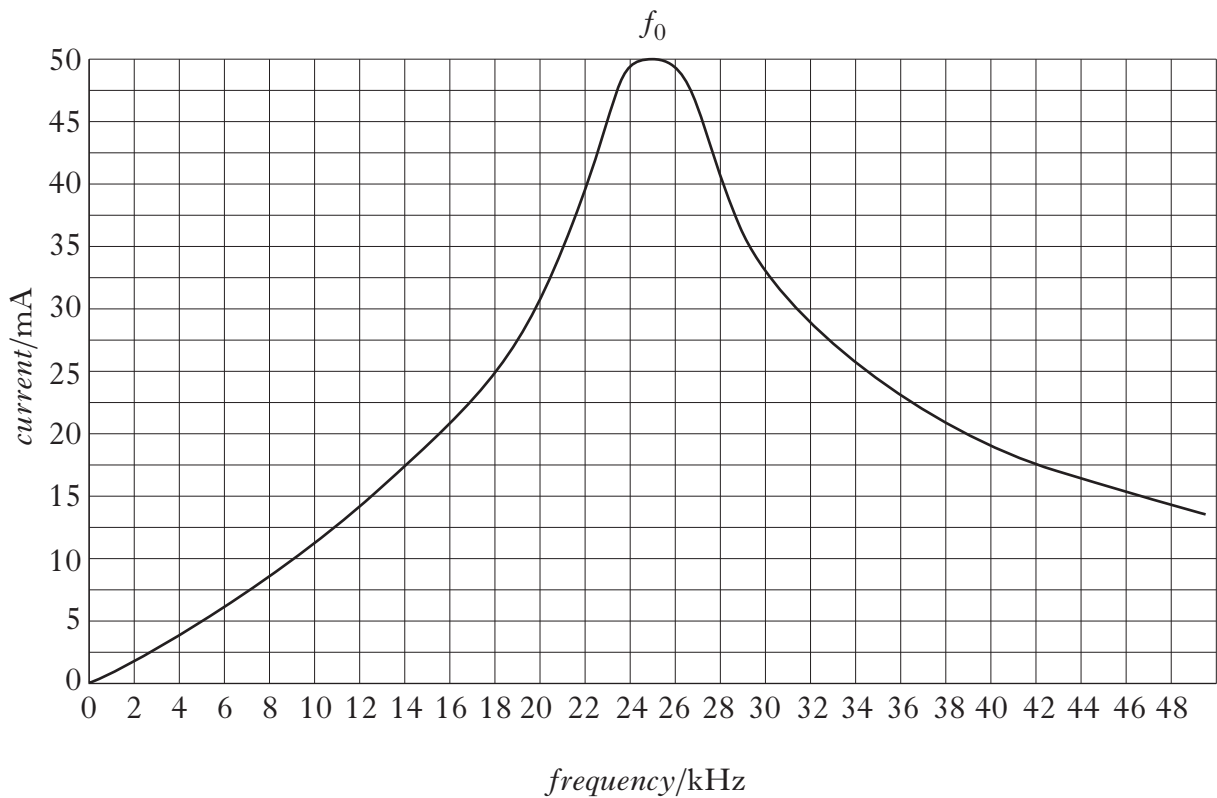

Figure 15B

15. (continued)

- (a) Show that the resonant frequency f_0 is given by

$$f_0 = \frac{1}{2\pi\sqrt{LC}}. \quad \mathbf{1}$$

- (b) The capacitance of C is $2.0\ \mu\text{F}$. Calculate the inductance of L. **2**

- (c) The student wants to change the design of this circuit in order to double the resonant frequency. Describe, in detail, a change the student could make to achieve this. **2**

(5)**16.** A student is investigating polarisation of waves.

- (a) State what is meant by *plane polarised light*. **1**

- (b) While doing some background reading the student discovers that the Brewster angle i_p for the liquid solvent triethylamine is given as 54.5° . Explain, using a diagram, what is meant by the Brewster angle. **2**

(3)

[END OF QUESTION PAPER]

[BLANK PAGE]

X272/13/01

NATIONAL MONDAY, 27 MAY
QUALIFICATIONS 1.00 PM – 3.30 PM
2013

PHYSICS
ADVANCED HIGHER
(Revised)

Relationships required for Advanced Higher Physics (Revised)

(For reference, relationships required for Higher Physics (Revised) are also included on *Page four*)

Relationships required for Physics Advanced Higher (Revised)

$$v = \frac{ds}{dt}$$

$$a = \frac{dv}{dt} = \frac{d^2s}{dt^2}$$

$$v = u + at$$

$$s = ut + \frac{1}{2}at^2$$

$$v^2 = u^2 + 2as$$

$$\omega = \frac{d\theta}{dt}$$

$$\alpha = \frac{d\omega}{dt} = \frac{d^2\theta}{dt^2}$$

$$\omega = \omega_o + \alpha t$$

$$\theta = \omega_o t + \frac{1}{2}\alpha t^2$$

$$\omega^2 = \omega_o^2 + 2\alpha\theta$$

$$s = r\theta$$

$$v = r\omega$$

$$a_t = r\alpha$$

$$a_r = \frac{v^2}{r} = r\omega^2$$

$$F = \frac{mv^2}{r} = mr\omega^2$$

$$T = Fr$$

$$T = I\alpha$$

$$L = mvr = mr^2\omega$$

$$L = I\omega$$

$$E_k = \frac{1}{2}I\omega^2$$

$$F = G \frac{Mm}{r^2}$$

$$V = -\frac{GM}{r}$$

$$v = \sqrt{\frac{2GM}{r}}$$

apparent brightness, $b = \frac{L}{4\pi r^2}$

Power per unit area = σT^4

$$L = 4\pi r^2 \sigma T^4$$

$$r_{\text{Schwarzschild}} = \frac{2GM}{c^2}$$

$$E = hf$$

$$\lambda = \frac{h}{p}$$

$$mvr = \frac{nh}{2\pi}$$

$$\Delta x \Delta p_x \geq \frac{h}{4\pi}$$

$$\Delta E \Delta t \geq \frac{h}{4\pi}$$

$$F = qvB$$

$$\omega = 2\pi f$$

$$a = \frac{d^2y}{dt^2} = -\omega^2 y$$

$$y = A \cos \omega t \quad \text{or} \quad y = A \sin \omega t$$

$$v = \pm \omega \sqrt{(A^2 - y^2)}$$

$$E_K = \frac{1}{2} m \omega^2 (A^2 - y^2)$$

$$E_P = \frac{1}{2} m \omega^2 y^2$$

$$y = A \sin 2\pi \left(ft - \frac{x}{\lambda} \right)$$

$$\phi = \frac{2\pi x}{\lambda}$$

$$\text{optical path difference} = m\lambda \quad \text{or} \quad \left(m + \frac{1}{2} \right) \lambda$$

where $m = 0, 1, 2, \dots$

$$\Delta x = \frac{\lambda l}{2d}$$

$$d = \frac{\lambda}{4n}$$

$$\Delta x = \frac{\lambda D}{d}$$

$$n = \tan i_p$$

$$F = \frac{Q_1 Q_2}{4\pi \epsilon_0 r^2}$$

$$E = \frac{Q}{4\pi \epsilon_0 r^2}$$

$$V = \frac{Q}{4\pi \epsilon_0 r}$$

$$F = QE$$

$$V = Ed$$

$$F = IlB \sin \theta$$

$$B = \frac{\mu_0 I}{2\pi r}$$

$$c = \frac{1}{\sqrt{\epsilon_0 \mu_0}}$$

$$t = RC$$

$$X_C = \frac{V}{I}$$

$$X_C = \frac{1}{2\pi f C}$$

$$\mathcal{E} = -L \frac{dI}{dt}$$

$$E = \frac{1}{2} LI^2$$

$$X_L = \frac{V}{I}$$

$$X_L = 2\pi f L$$

$$\frac{\Delta W}{W} = \sqrt{\left(\frac{\Delta X}{X} \right)^2 + \left(\frac{\Delta Y}{Y} \right)^2 + \left(\frac{\Delta Z}{Z} \right)^2}$$

$$\Delta W = \sqrt{\Delta X^2 + \Delta Y^2 + \Delta Z^2}$$

$$d = \bar{v}t$$

$$s = \bar{v}t$$

$$v = u + at$$

$$s = ut + \frac{1}{2}at^2$$

$$v^2 = u^2 + 2as$$

$$s = \frac{1}{2}(u + v)t$$

$$W = mg$$

$$F = ma$$

$$E_w = Fd$$

$$E_p = mgh$$

$$E_k = \frac{1}{2}mv^2$$

$$P = \frac{E}{t}$$

$$p = mv$$

$$Ft = mv - mu$$

$$F = G \frac{Mm}{r^2}$$

$$t' = \frac{t}{\sqrt{1 - \left(\frac{v}{c}\right)^2}}$$

$$l' = l\sqrt{1 - \left(\frac{v}{c}\right)^2}$$

$$f_o = f_s \left(\frac{v}{v \pm v_s} \right)$$

$$z = \frac{\lambda_{\text{observed}} - \lambda_{\text{rest}}}{\lambda_{\text{rest}}}$$

$$z = \frac{v}{c}$$

$$v = H_0d$$

$$E_w = QV$$

$$E = mc^2$$

$$E = hf$$

$$E_k = hf - hf_0$$

$$E_2 - E_1 = hf$$

$$T = \frac{1}{f}$$

$$v = f\lambda$$

$$d \sin \theta = m\lambda$$

$$n = \frac{\sin \theta_1}{\sin \theta_2}$$

$$\frac{\sin \theta_1}{\sin \theta_2} = \frac{\lambda_1}{\lambda_2} = \frac{v_1}{v_2}$$

$$\sin \theta_c = \frac{1}{n}$$

$$I = \frac{k}{d^2}$$

$$I = \frac{P}{A}$$

$$\text{path difference} = m\lambda \quad \text{or} \quad \left(m + \frac{1}{2}\right)\lambda \quad \text{where } m = 0, 1, 2, \dots$$

$$\text{random uncertainty} = \frac{\text{max. value} - \text{min. value}}{\text{number of values}}$$

$$V_{\text{peak}} = \sqrt{2}V_{\text{rms}}$$

$$I_{\text{peak}} = \sqrt{2}I_{\text{rms}}$$

$$Q = It$$

$$V = IR$$

$$P = IV = I^2R = \frac{V^2}{R}$$

$$R_T = R_1 + R_2 + \dots$$

$$\frac{1}{R_T} = \frac{1}{R_1} + \frac{1}{R_2} + \dots$$

$$E = V + Ir$$

$$V_1 = \left(\frac{R_1}{R_1 + R_2} \right) V_s$$

$$\frac{V_1}{V_2} = \frac{R_1}{R_2}$$

$$C = \frac{Q}{V}$$

$$E = \frac{1}{2}QV = \frac{1}{2}CV^2 = \frac{1}{2} \frac{Q^2}{C}$$