



National
Qualifications
SPECIMEN ONLY

S807/77/02

Biology
Section 1 — Questions

Date — Not applicable

Duration — 3 hours

Instructions for the completion of Section 1 are given on *page 02* of your question and answer booklet S807/77/01.

Record your answers on the answer grid on *page 03* of your question and answer booklet.

Before leaving the examination room you must give your question and answer booklet to the Invigilator; if you do not, you may lose all the marks for this paper.



* S 8 0 7 7 7 0 2 *

SECTION 1 — 20 marks

Attempt ALL questions

1. The diagram shows a haemocytometer grid that was used to estimate the number of cells in a 10 cm^3 microbial culture. The depth of the counting chamber is 0.2 mm .

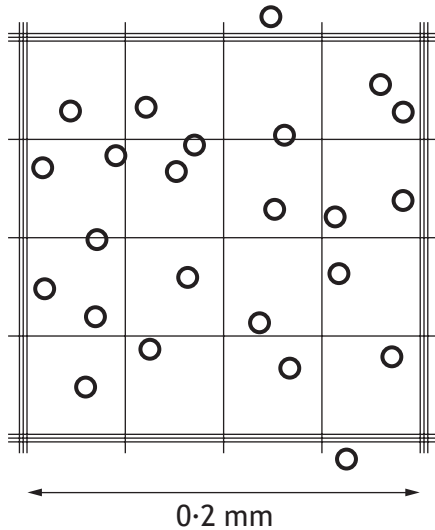

The number of cells in the 10 cm^3 culture was

- A 2.75×10^7
B 2.5×10^7
C 2.25×10^7
D 1.6×10^3
2. Which of the following is a covalent bond that stabilises the tertiary structure of a protein?
- A Disulphide bridge
B Hydrogen bond
C Ionic bond
D Hydrophobic interactions
3. A hydrophobic amino acid has an R group that is
- A negatively charged
B positively charged
C not polar
D polar.

4. A buffered solution of four amino acids was applied to the midline of a strip of electrophoresis gel. The result of running the gel is shown.

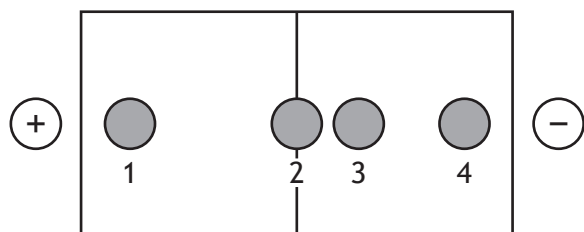

Which amino acid was at its isoelectric point?

- A 1
- B 2
- C 3
- D 4

[Turn over

5. The table shows the number of amino acids in a particular protein and the charge of each amino acid at a certain pH.

Amino acid	Charge	Number
Arginine	positive	13
Aspartate	negative	9
Cysteine	negative	2
Histidine	positive	2
Glutamate	negative	20
Lysine	positive	19
Tyrosine	negative	7

Assuming that each amino acid carries a single positive or negative charge, what is the protein's net charge at this pH?

- A -4
- B -38
- C +4
- D +38

6. The diagram shows how phosphate is used to modify the conformation of an enzyme, phosphorylase, and so change its activity.

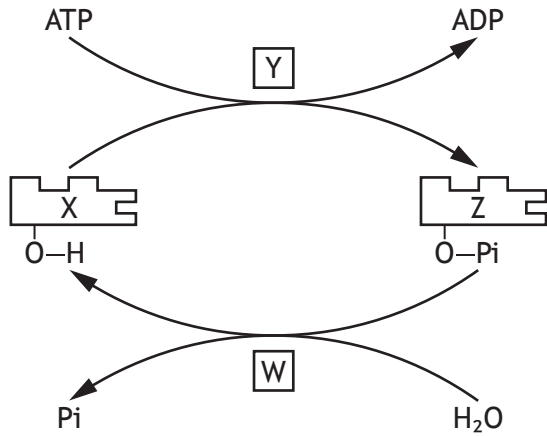

Which row in the table identifies the labels?

	Kinase	Phosphatase	Phosphorylase
A	Y	Z	W
B	W	Y	Z
C	X	Y	W
D	Y	W	Z

[Turn over

7. The diagram shows the distribution of protein molecules in a cell membrane.

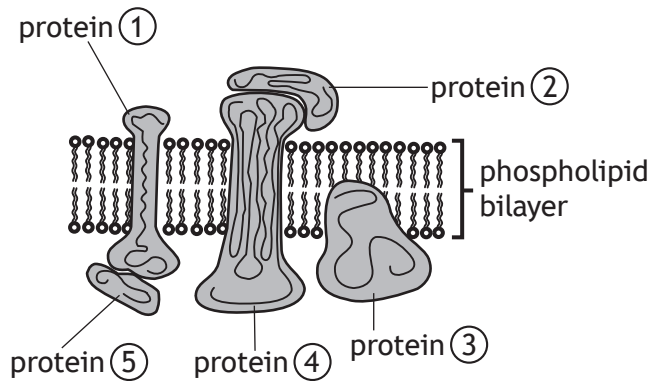

Which row in the table identifies a peripheral and an integral membrane protein?

	Peripheral membrane protein	Integral membrane protein
A	1	5
B	2	1
C	3	4
D	5	2

8. The sodium-potassium pump spans the plasma membrane. Various processes involved in the active transport of sodium and potassium ions take place either inside the cell (intracellular) or outside the cell (extracellular).

Which row in the table applies to the binding of potassium ions?

	Binding location of potassium ions	Conformation of transport protein
A	extracellular	not phosphorylated
B	intracellular	not phosphorylated
C	extracellular	phosphorylated
D	intracellular	phosphorylated

9. A student planned to measure the activity of catalase by using an oxygen probe to measure oxygen production. As part of their pilot study, the student used a standard sample with an oxygen concentration of 22.00% to test the accuracy and precision of the probe.

Four readings of the standard sample were taken and the results obtained are shown in the table.

	Reading			
	1	2	3	4
Oxygen concentration (%)	20.94	20.93	20.93	20.94

The results indicate the measurements taken were

- A accurate and precise
- B accurate but not precise
- C precise but not accurate
- D neither accurate nor precise.

[Turn over

10. The diagrams represent stages in an immunoassay used to detect the presence of a poisonous toxin in food samples. The test shown is positive.

Which of the following shows the sequence of stages in the immunoassay?

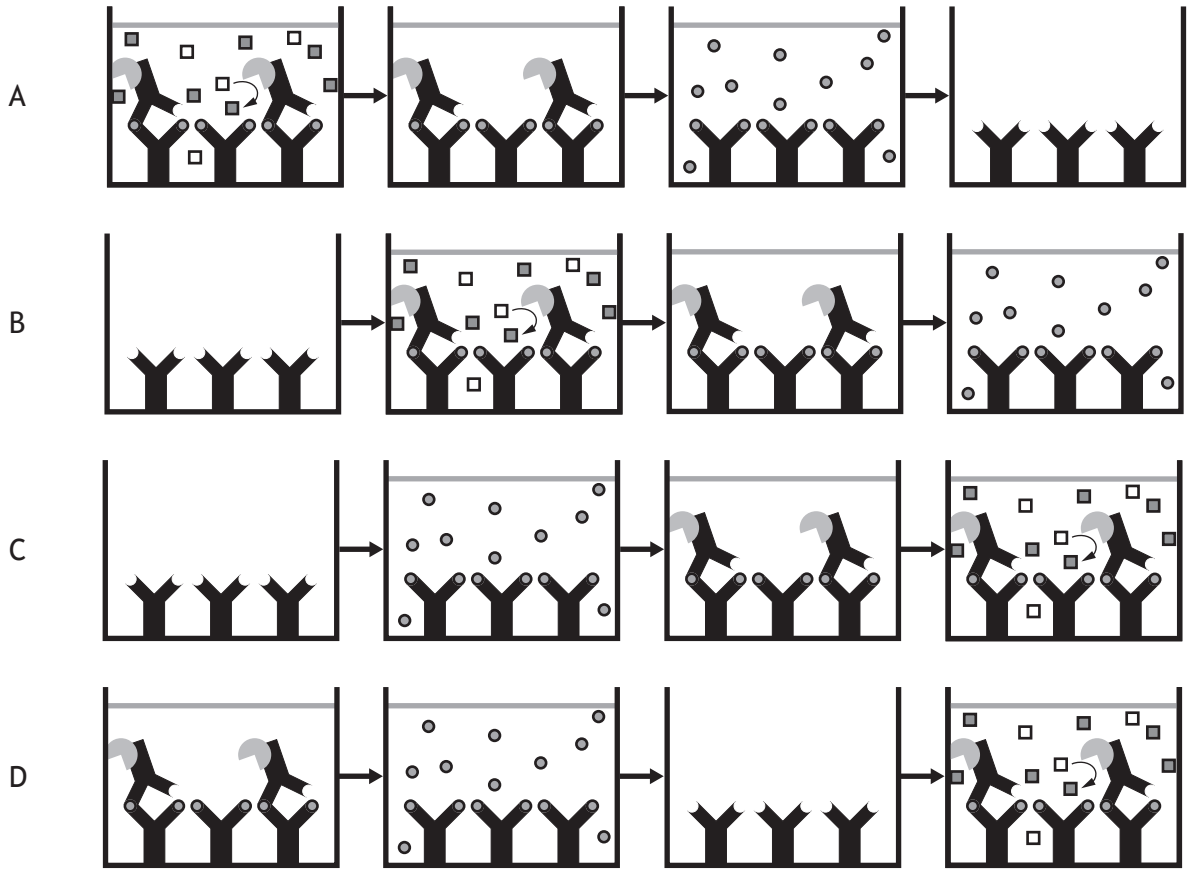

11. Animal cells growing in culture are found to spend 20% of their time in the G2 phase of the cell cycle. G2 lasts for 4 hours.

If cells spend 12% of their time in the M phase, how long does this last?

- A 2 hours 4 minutes
- B 2 hours 12 minutes
- C 2 hours 24 minutes
- D 2 hours 40 minutes

12. Which of the following would be true if a population's gene pool remained unaltered for many generations?

- A Mating was random
- B Migration was common
- C Genetic drift had occurred
- D Certain alleles had a selective advantage

13. In a population that is in Hardy-Weinberg equilibrium, the frequency of the recessive allele for a particular trait is 0.7.

The proportion of individuals heterozygous for this trait is

- A 0.09
- B 0.21
- C 0.42
- D 0.49

14. Which row in the table applies to r-selected species?

	Many offspring produced	Prolonged parental care
A	yes	yes
B	yes	no
C	no	yes
D	no	no

[Turn over

15. The error bars on the graphs represent standard errors in the mean (SEM).
Which graph shows reliable data that may be significantly different?

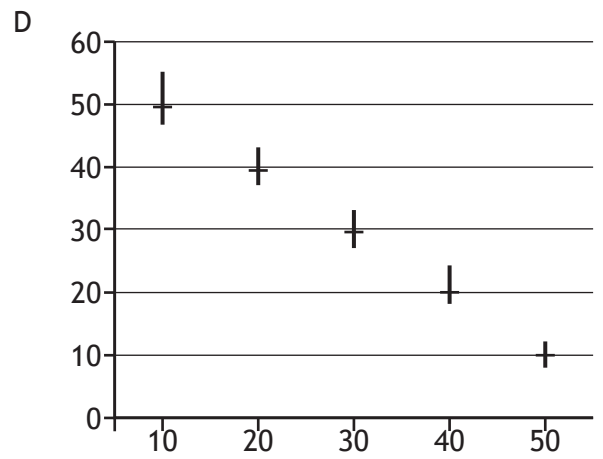
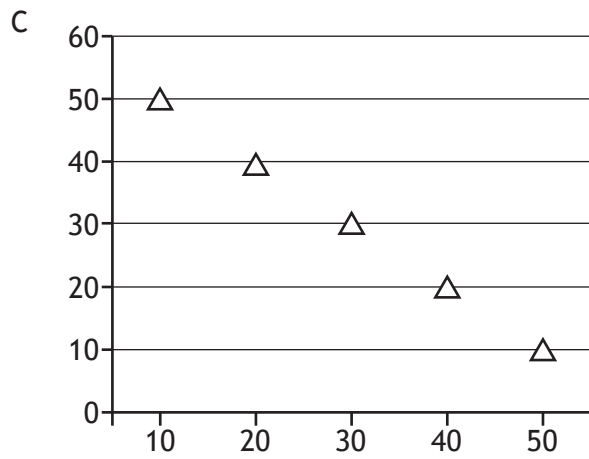
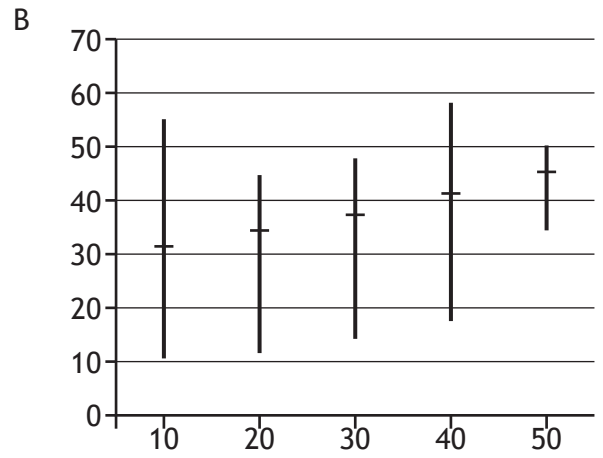
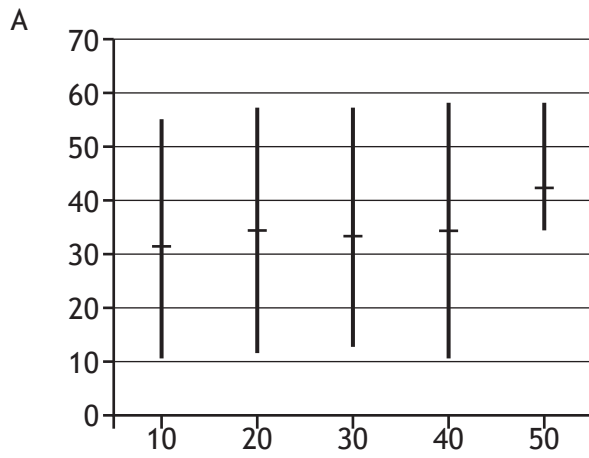

16. *Anolis* lizards are found on Caribbean islands. They feed on prey of various sizes.

Histogram 1 shows the range of prey length eaten by *Anolis marmoratus* on the island of Jarabacoa, where there are five other *Anolis* species.

Histogram 2 shows the range of prey length eaten by *Anolis marmoratus* on the island of Marie Galante, where it is the only *Anolis* species.

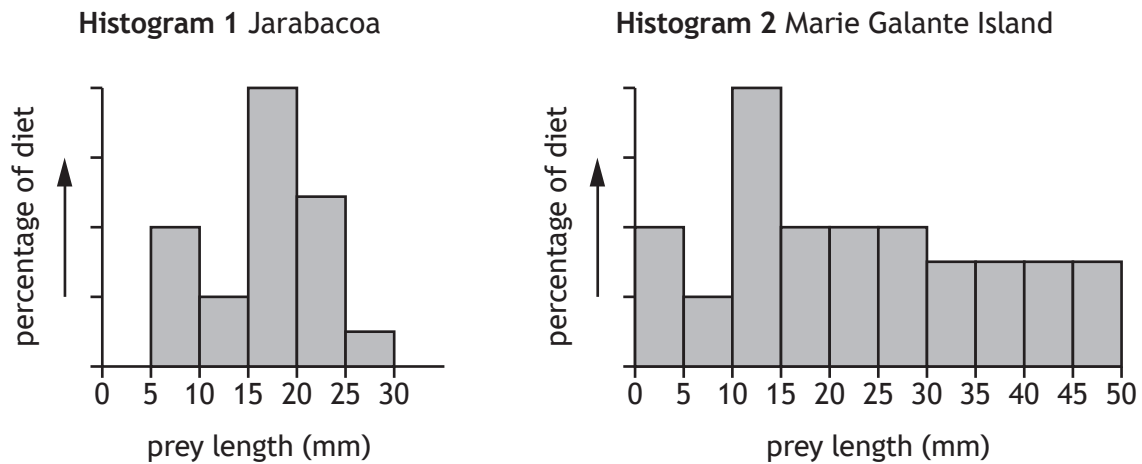

Which of the following statements could explain the different range of prey sizes eaten by *Anolis marmoratus* on the two islands?

- A Larger numbers of prey are found on Marie Galante
 - B *Anolis marmoratus* occupies its fundamental niche on Jarabacoa
 - C *Anolis marmoratus* occupies its realised niche on Marie Galante
 - D Resource partitioning takes place on Jarabacoa
17. Herd immunity threshold is
- A the density of hosts in a population required to prevent an epidemic
 - B the density of resistant hosts in a population required to prevent an epidemic
 - C the density of hosts in a population required for transmission to cause an epidemic
 - D the density of parasites in a population required to cause an epidemic.
18. Reverse transcriptase catalyses the production of
- A DNA from RNA
 - B DNA from DNA
 - C mRNA from DNA
 - D tRNA from mRNA.

[Turn over

19. Which of the following would **not** provide long-term control of parasites following a natural disaster?
- A Immunisation
 - B Improved sanitation
 - C Co-ordinated vector control
 - D Drug treatment of infected humans
20. A population of chafer beetles were damaging the tees and greens of a golf course. Results from a mark and recapture study suggested a population size that was too small to account for the extent of the damage caused.
- One possible reason for this is that
- A the white paint used to mark the beetles washed off some of them before the recapture
 - B the white paint used to mark the beetles made them more visible to predators than unmarked beetles
 - C the total number of beetles in the recaptured sample was less than the number first captured and marked
 - D the marked beetles did not have enough time, after release, to spread out and mix with the rest of the population.

**[END OF SECTION 1. NOW ATTEMPT THE QUESTIONS IN SECTION 2
OF YOUR QUESTION AND ANSWER BOOKLET]**

FOR OFFICIAL USE



National
Qualifications
SPECIMEN ONLY

Mark

S807/77/01

**Biology
Section 1 — Answer grid
and Section 2**

Date — Not applicable

Duration — 3 hours



* S 8 0 7 7 7 0 1 *

Fill in these boxes and read what is printed below.

Full name of centre

Town

Forename(s)

Surname

Number of seat

Date of birth

Day

Month

Year

Scottish candidate number

Total marks — 100

SECTION 1 — 20 marks

Attempt ALL questions.

Instructions for the completion of Section 1 are given on *page 02*.

SECTION 2 — 80 marks

Attempt ALL questions.

A supplementary sheet for question 1 is enclosed inside the front cover of this question paper.

Write your answers clearly in the spaces provided in this booklet. Additional space for answers and rough work is provided at the end of this booklet. If you use this space you must clearly identify the question number you are attempting. Any rough work must be written in this booklet. Score through your rough work when you have written your final copy.

Use **blue** or **black** ink.

Before leaving the examination room you must give this booklet to the Invigilator; if you do not, you may lose all the marks for this paper.



* S 8 0 7 7 7 0 1 0 1 *

The questions for Section 1 are contained in the question paper S807/77/02.

Read these and record your answers on the answer grid on *page 03* opposite.

Use **blue** or **black** ink. Do NOT use gel pens or pencil.

1. The answer to each question is **either** A, B, C or D. Decide what your answer is, then fill in the appropriate bubble (see sample question below).
2. There is **only one correct** answer to each question.
3. Any rough working should be done on the additional space for answers and rough work at the end of this booklet.

Sample question

The thigh bone is called the

- A humerus
- B femur
- C tibia
- D fibula.

The correct answer is **B** — femur. The answer **B** bubble has been clearly filled in (see below).

A	B	C	D
<input type="radio"/>	<input checked="" type="radio"/>	<input type="radio"/>	<input type="radio"/>

Changing an answer

If you decide to change your answer, cancel your first answer by putting a cross through it (see below) and fill in the answer you want. The answer below has been changed to **D**.

A	B	C	D
<input type="radio"/>	<input checked="" type="radio"/>	<input type="radio"/>	<input checked="" type="radio"/>

If you then decide to change back to an answer you have already scored out, put a tick (✓) to the **right** of the answer you want, as shown below:

A	B	C	D	or	A	B	C	D
<input type="radio"/>	<input checked="" type="radio"/>	<input type="radio"/>	<input checked="" type="radio"/>		<input type="radio"/>	<input checked="" type="radio"/>	<input type="radio"/>	<input type="radio"/>



SECTION 1 — Answer grid



	A	B	C	D
1	<input type="radio"/>	<input type="radio"/>	<input type="radio"/>	<input type="radio"/>
2	<input type="radio"/>	<input type="radio"/>	<input type="radio"/>	<input type="radio"/>
3	<input type="radio"/>	<input type="radio"/>	<input type="radio"/>	<input type="radio"/>
4	<input type="radio"/>	<input type="radio"/>	<input type="radio"/>	<input type="radio"/>
5	<input type="radio"/>	<input type="radio"/>	<input type="radio"/>	<input type="radio"/>
6	<input type="radio"/>	<input type="radio"/>	<input type="radio"/>	<input type="radio"/>
7	<input type="radio"/>	<input type="radio"/>	<input type="radio"/>	<input type="radio"/>
8	<input type="radio"/>	<input type="radio"/>	<input type="radio"/>	<input type="radio"/>
9	<input type="radio"/>	<input type="radio"/>	<input type="radio"/>	<input type="radio"/>
10	<input type="radio"/>	<input type="radio"/>	<input type="radio"/>	<input type="radio"/>
11	<input type="radio"/>	<input type="radio"/>	<input type="radio"/>	<input type="radio"/>
12	<input type="radio"/>	<input type="radio"/>	<input type="radio"/>	<input type="radio"/>
13	<input type="radio"/>	<input type="radio"/>	<input type="radio"/>	<input type="radio"/>
14	<input type="radio"/>	<input type="radio"/>	<input type="radio"/>	<input type="radio"/>
15	<input type="radio"/>	<input type="radio"/>	<input type="radio"/>	<input type="radio"/>
16	<input type="radio"/>	<input type="radio"/>	<input type="radio"/>	<input type="radio"/>
17	<input type="radio"/>	<input type="radio"/>	<input type="radio"/>	<input type="radio"/>
18	<input type="radio"/>	<input type="radio"/>	<input type="radio"/>	<input type="radio"/>
19	<input type="radio"/>	<input type="radio"/>	<input type="radio"/>	<input type="radio"/>
20	<input type="radio"/>	<input type="radio"/>	<input type="radio"/>	<input type="radio"/>



SECTION 2 — 80 marks
Attempt ALL questions
Question 13 contains a choice

DO NOT
WRITE IN
THIS
MARGIN

1. Read through the supplementary sheet for question 1 before attempting this question.

(a) State the term that describes the entire set of proteins expressed by a genome.

1

(b) Describe the process by which the knockout of DGCR8 affects RNA interference.

2

(c) (i) Describe what happens during the G1 phase of the cell cycle.

1

(ii) Refer to **Figure 2A**.

Calculate the percentage reduction in growth at 90 hours caused by the microRNA knockout.

1

Space for calculation

_____ %

(iii) Refer to **Figure 2B**.

The researchers concluded that microRNA knockout cells do not progress normally through the cell cycle.

Explain how the results in **Figure 2B** support this conclusion.

2



* S 8 0 7 7 7 0 1 0 4 *

1. (continued)

- (d) (i) Refer to Figures 3A and 3B.

Give one general conclusion about the expression of the differentiation marker by comparing normal and knockout cells.

1

- (ii) There is a hypothesis that self-renewal is switched off as differentiation proceeds and that the interaction of these two processes is abnormal in knockout cells.

Explain how the data support this hypothesis.

2

[Turn over



* S 8 0 7 7 7 0 1 0 5 *

2. Cortisol is a hydrophobic signalling molecule, produced by the human adrenal gland, that affects a number of different tissues in response to stress. It has a role in increasing blood sugar levels, in suppressing the immune system and in promoting the metabolism of fats, proteins and carbohydrates.

- (a) (i) Cortisol is a steroid hormone.

Describe the mechanism by which this type of signalling molecule causes an effect within the target cell.

3

- (ii) Suggest a way in which cortisol might have different effects in different tissues.

1



* S 8 0 7 7 7 0 1 0 6 *

2. (continued)

(b) Addison's disease is a disorder in which the adrenal glands do not produce sufficient cortisol. One test for this disease is to give the patient an injection of a hormone called ACTH, which stimulates the adrenal gland to release cortisol. In a healthy person, cortisol levels should rise by at least 70 μg per litre after 30 minutes and 110 μg per litre after 60 minutes.

The graph shows the results of this test on three patients who were investigated for Addison's disease.

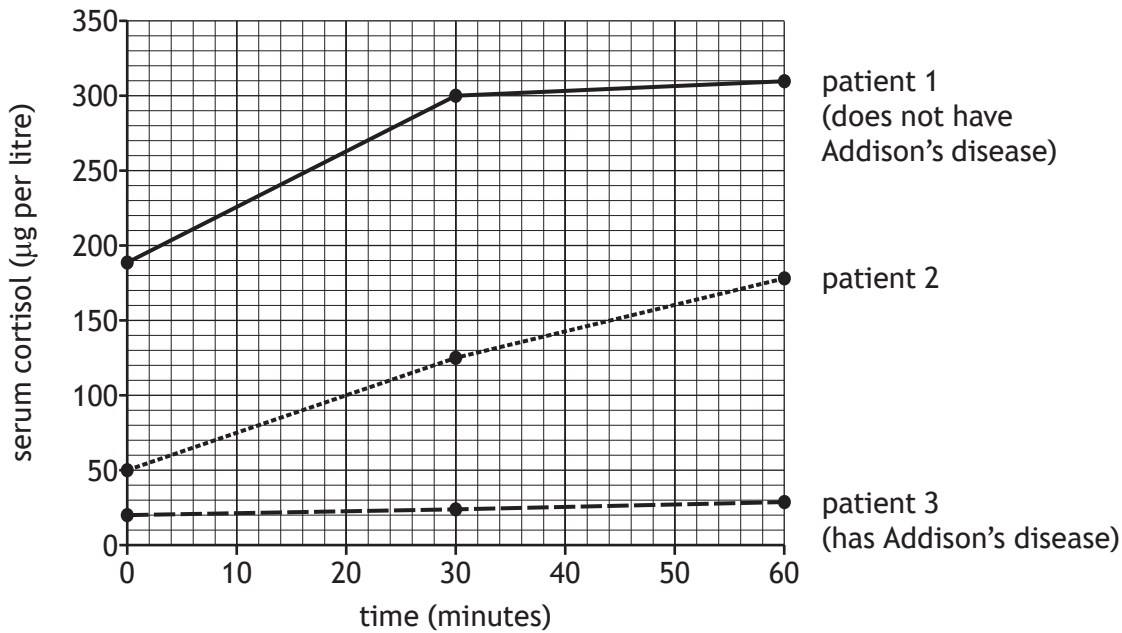

State the diagnosis that would be appropriate for patient 2, using data to justify your answer.

1

[Turn over



3. Gamma-aminobutyric acid (GABA) is a neurotransmitter that functions as a signalling molecule in the central nervous system. GABA binds to a receptor protein located in the plasma membrane of target cells as shown in **Figure 1**. Binding of a GABA molecule opens a channel that allows chloride ions (Cl^-) to enter the cell.

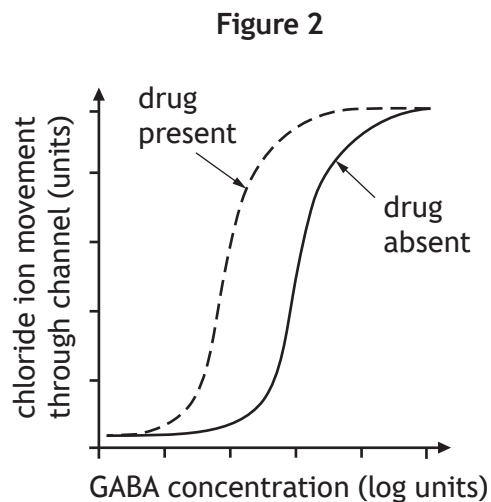
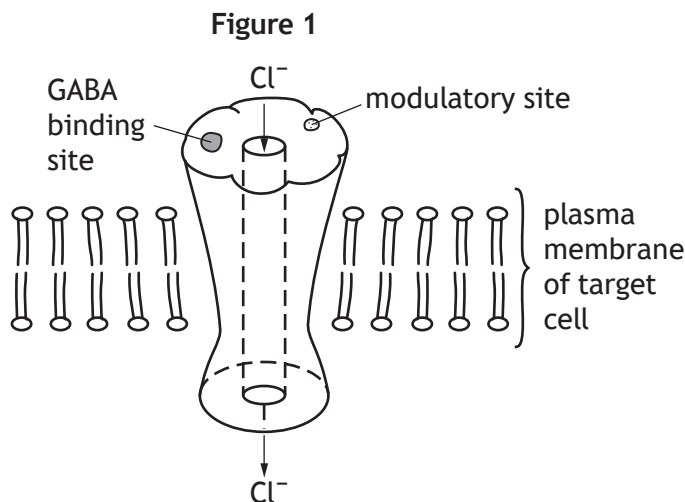

Benzodiazepines are sedative drugs that bind to the receptor protein and increase its affinity for GABA. These drugs act as allosteric modulators by binding at a site that is distinct from the GABA-binding site. **Figure 2** shows the movement of chloride ions through the channel as GABA is increased with and without the drug being present.

- (a) Using the information provided, explain why the GABA receptor is described as a ligand-gated channel. 2

- (b) State the term that describes the action of a membrane receptor in which signal binding brings about an effect in the cytoplasm. 1

- (c) (i) Describe the information in **Figure 2** that shows that the affinity of the receptor for GABA has been increased by the benzodiazepine. 1



MARKS

DO NOT
WRITE IN
THIS
MARGIN

3. (c) (continued)

- (ii) Explain why the affinity of the receptor for GABA increases when the drug binds to the modulatory site.

1

- (d) Explain why the opening of GABA channels would make the generation of a nerve impulse less likely.

2

[Turn over



* S 8 0 7 7 7 0 1 0 9 *

4. An investigation into the effects of different concentrations of ATP on muscle tissue used muscle from three pork chops (A, B and C), all bought from the same shop.

Three thin strips of muscle were cut from each chop and placed on microscope slides. The length of each strip was measured and recorded.

Equal volumes of a 10% ATP solution were added to one strip of muscle from each chop and the length of each measured again.

The experiment was repeated using a 5% ATP solution on the second set of strips and distilled water on the final set.

- (a) Identify the independent variable in this experiment. 1

- (b) Two confounding variables in this experiment are temperatures of the solutions and muscle strips during the experiment, and the breed of pig that the chops came from.

- (i) Suggest one further confounding variable in this experiment. 1

- (ii) Explain one way in which this variable could affect the outcome of this experiment. 1

The table shows the data collected.

Solution added to strip	Pork chop strip sample	Initial length (mm)	Final length (mm)	Change in length (mm)
10% ATP	A	10	8	2
	B	11	8	3
	C	10	11	1
5% ATP	A	12	11	1
	B	13	12	1
	C	11	10	1
Distilled water	A	12	12	0
	B	12	13	1
	C	9	10	1



4. (continued)

(c) State whether or not the data is reliable. Explain your answer.

2

(d) Name the type of control used in this experiment.

1

(e) Suggest how selection bias has affected the validity of this experiment.

1

[Turn over



* S 8 0 7 7 7 0 1 1 1 *

5. When insulin attaches to its receptor in the plasma membrane of fat cells and muscle cells, GLUT 4 glucose transporter proteins in the cytoplasm are recruited into the membrane to take in glucose. Type 2 diabetes is associated with insulin resistance in which cells are less able to respond to insulin in this way.

A study concluded that moderate strength training increases the GLUT 4 content of muscle tissue in those with type 2 diabetes. Individuals taking part all did strength training on one leg (T leg) for six weeks while the other leg was left untrained (UT leg). The individuals either had type 2 diabetes or did not. At the end of the training, muscle biopsies (samples) were taken from the trained and untrained legs and compared for GLUT 4 protein content. The results are shown in the graph.

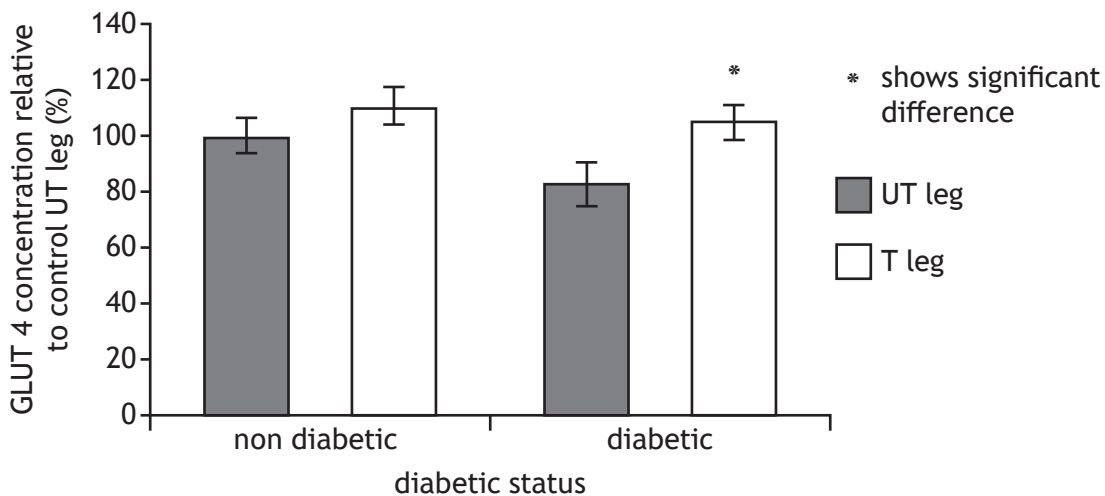

- (a) State a suitable null hypothesis in this investigation.

1

- (b) The researchers concluded that moderate strength training increases the GLUT 4 content of muscle tissue **only** in those with type 2 diabetes. Explain how the data support this conclusion.

2

- (c) State why the treatment regimes for individuals with type 1 diabetes may differ from individuals with type 2 diabetes.

1



6. Rod cells and cone cells are photoreceptors in vertebrate eyes. Membranes in these cells contain rhodopsin, a protein molecule that has a light-absorbing component. Rhodopsin generates a nerve impulse when light is absorbed.

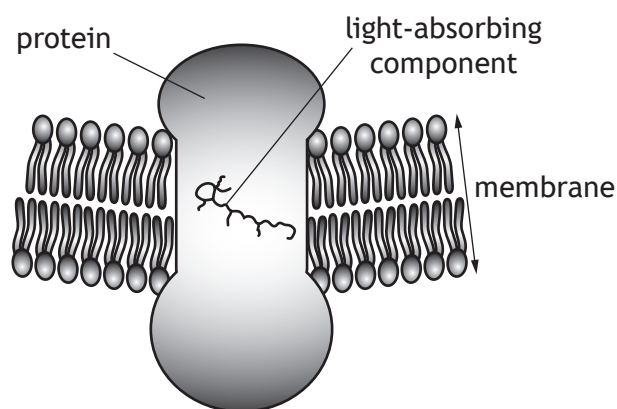

- (a) Name the light-absorbing component of rhodopsin. 1

- (b) Describe the mechanism by which the absorption of a photon by rhodopsin leads to the generation of a nerve impulse. 3

- (c) Give one feature of the photoreceptor system in rods that allows these cells to function in low light intensity. 1

[Turn over

7. The protein p53 plays an important role in controlling cell division. The diagram represents how the activation of p53 can result in arrest of the cell cycle.

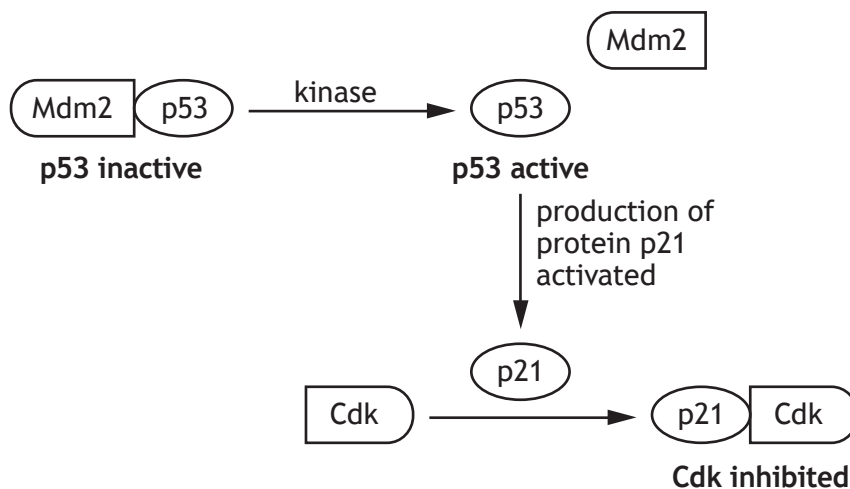

- (a) Suggest why the action of kinase disrupts the association between the two proteins Mdm2 and p53.

1

- (b) Explain why binding of p21 protein to cyclin dependent kinase (Cdk) prevents the cell cycle from progressing.

2

- (c) State **one** trigger that would stimulate the activation of p53.

1

- (d) State one other fate, apart from arrest of the cell cycle, of a cell that has had p53 activated.

1



MARKS

DO NOT
WRITE IN
THIS
MARGIN

8. Describe the structure of spindle fibres and explain their role in the movement of chromosomes during cell division.

4

[Turn over



* S 8 0 7 7 7 0 1 1 5 *

9. A type of haemophilia results when a gene that codes for a blood clotting factor, factor VIII, is mutated. This gene is located on the X chromosome. Mutated alleles do not produce functional factor VIII.

(a) Explain why men are more likely than women to be affected by this type of haemophilia.

2

(b) An unaffected man and a carrier woman have a daughter and a son. State the percentage probability of each child being able to produce functional factor VIII.

2

Space for calculation

Daughter _____%

Son _____%

(c) (i) Explain the importance of inactivation of the X chromosome in females.

1

(ii) Analysis of a female carrier showed that her blood contained only 42% of the normal levels of functional factor VIII.

Suggest why this value was lower than predicted.

1



10. The figure shows the life cycle of the macroparasitic flatworm called *Schistosoma japonicum*. The flatworm can live for many years within a host. In humans, if untreated, it causes the disease schistosomiasis (bilharzia) that can be fatal.

Life cycle of *Schistosoma japonicum*

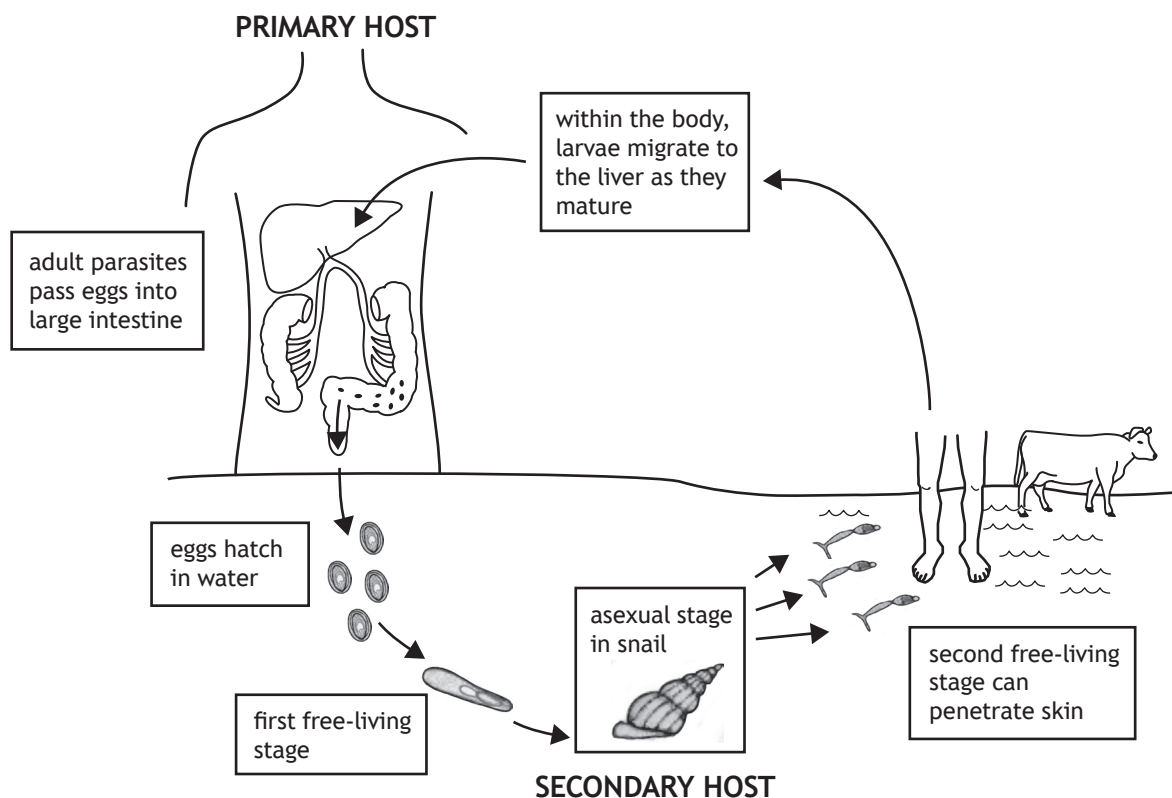

- (a) (i) Explain why the snail may not be described as a vector. 1
- (ii) Suggest a feature of this parasite's life cycle that can lead to an increased rate of transmission. 1

[Turn over



* S 8 0 7 7 7 0 1 1 7 *

10. (continued)

- (b) Parasites living inside a host will be exposed to attack by the host's immune system.

Describe one way in which parasites may overcome the immune response of their hosts.

1

- (c) Describe the Red Queen hypothesis.

2



11. Fur seals spend most of their lives feeding in Antarctic seas. During the short summer they come ashore to breed.



The graph shows the number of fur seals breeding on Signy Island from 1956 to 1986.

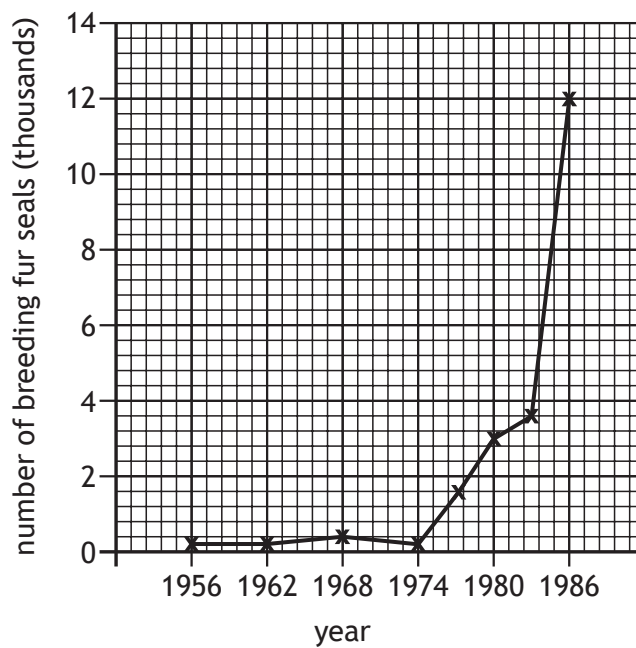

- (a) Calculate the percentage increase in the size of the breeding fur seal population between 1980 and 1986.

1

Space for calculation

_____ %



* S 8 0 7 7 7 0 1 1 9 *

11. (continued)

- (b) Permanent quadrats were established to investigate the effect of fur seals on ground cover plants. The table shows the mean percentage of cover of a number of plant species sampled in the permanent quadrats in 1965 and 1985.

Plant species	Percentage cover (%)	
	1965	1985
<i>Drepanocladus uncinatus</i>	30	0
<i>Bryum algens</i>	49	0
<i>Tortula filaris</i>	16	0
<i>Tortula saxicola</i>	4	4
<i>Prasiola crispa</i>	1	41

- (i) Explain the changes in percentage cover between 1965 and 1985. 2

- (ii) Suggest why the percentage cover in 1985 is not 100%. 1

- (c) (i) Give one consideration that must be taken into account when carrying out sampling in an ecosystem. 1

- (ii) Describe the process of stratified sampling. 1



12. Courtship behaviour in the dung beetle *Onthophagus sagittarius* was investigated in a laboratory.

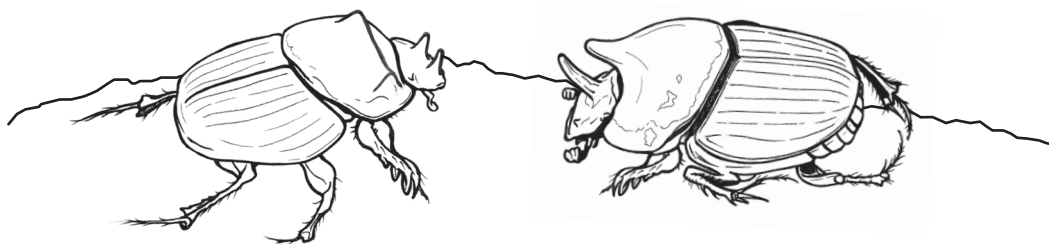

Beetles were paired by randomly selecting males and females, and the pairs were placed in breeding chambers. Mating success in relation to the frequency of courtship behaviour was recorded for large and small males.

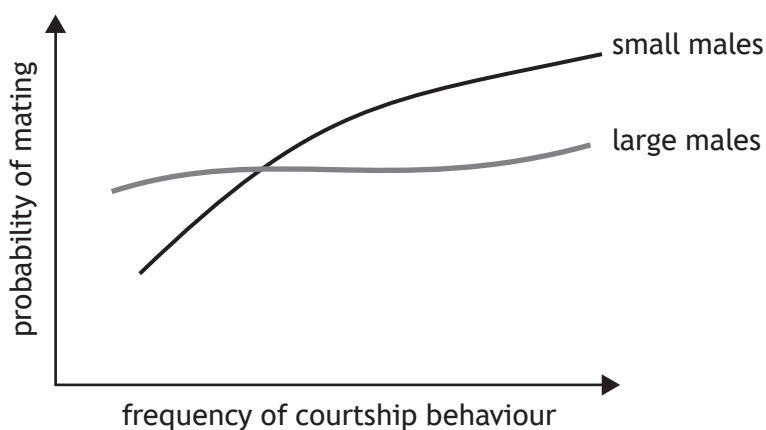

(a) From the results, describe how female choice changes in relation to male size. 1

(b) State the term used to indicate the time from introduction until first courtship during the experiment. 1

(c) Male and female dung beetles can be distinguished by their horns. State the term used to describe this difference in appearance. 1

(d) Females in many species are relatively inconspicuous. Suggest why this is of importance to them. 1

12. (continued)

- (e) In some species, females assess honest signals from males.

Explain why this behaviour is likely to increase the fitness of females.

2



* S 8 0 7 7 7 0 1 2 2 *

13. Attempt **either A or B**. Write your answer in the space below and on *page 25*.

A Discuss the formation of variable gametes during meiosis under the following headings.

(i) The activity of homologous chromosomes **8**

(ii) Meiosis II **2**

OR

B Discuss the process of evolution under the following headings.

(i) Importance of mutation in enabling evolution **6**

(ii) Factors increasing the rate of evolution **4**

You may use labelled diagrams where appropriate.



MARKS

DO NOT
WRITE IN
THIS
MARGIN

ADDITIONAL SPACE FOR ANSWER to question 13

[END OF SPECIMEN QUESTION PAPER]



* S 8 0 7 7 7 0 1 2 4 *

MARKS

DO NOT
WRITE IN
THIS
MARGIN

ADDITIONAL SPACE FOR ANSWERS AND ROUGH WORK



* S 8 0 7 7 7 0 1 2 5 *

MARKS

DO NOT
WRITE IN
THIS
MARGIN

ADDITIONAL SPACE FOR ANSWERS AND ROUGH WORK

Acknowledgement of copyright

Section 2 question 11 Artush/shutterstock.com



* S 8 0 7 7 7 0 1 2 6 *



National
Qualifications
SPECIMEN ONLY

S807/77/11

**Biology
Supplementary sheet**

Date — Not applicable

Duration — 3 hours

Supplementary sheet for question 1



* S 8 0 7 7 7 1 1 *



1. MicroRNA are a class of small RNA molecules that have an important role in controlling the translation of mRNA. This type of control is called RNA interference.

A microRNA is formed from a precursor RNA molecule that folds into a double-stranded 'hairpin' structure. The hairpin is then processed to give a shorter molecule by the enzymes 'Drosha' and 'Dicer'. One strand of this short molecule attaches to RISC proteins; the resulting complex binds to target mRNA molecules and prevents translation (Figure 1).

Figure 1 Control of gene expression by RNA interference

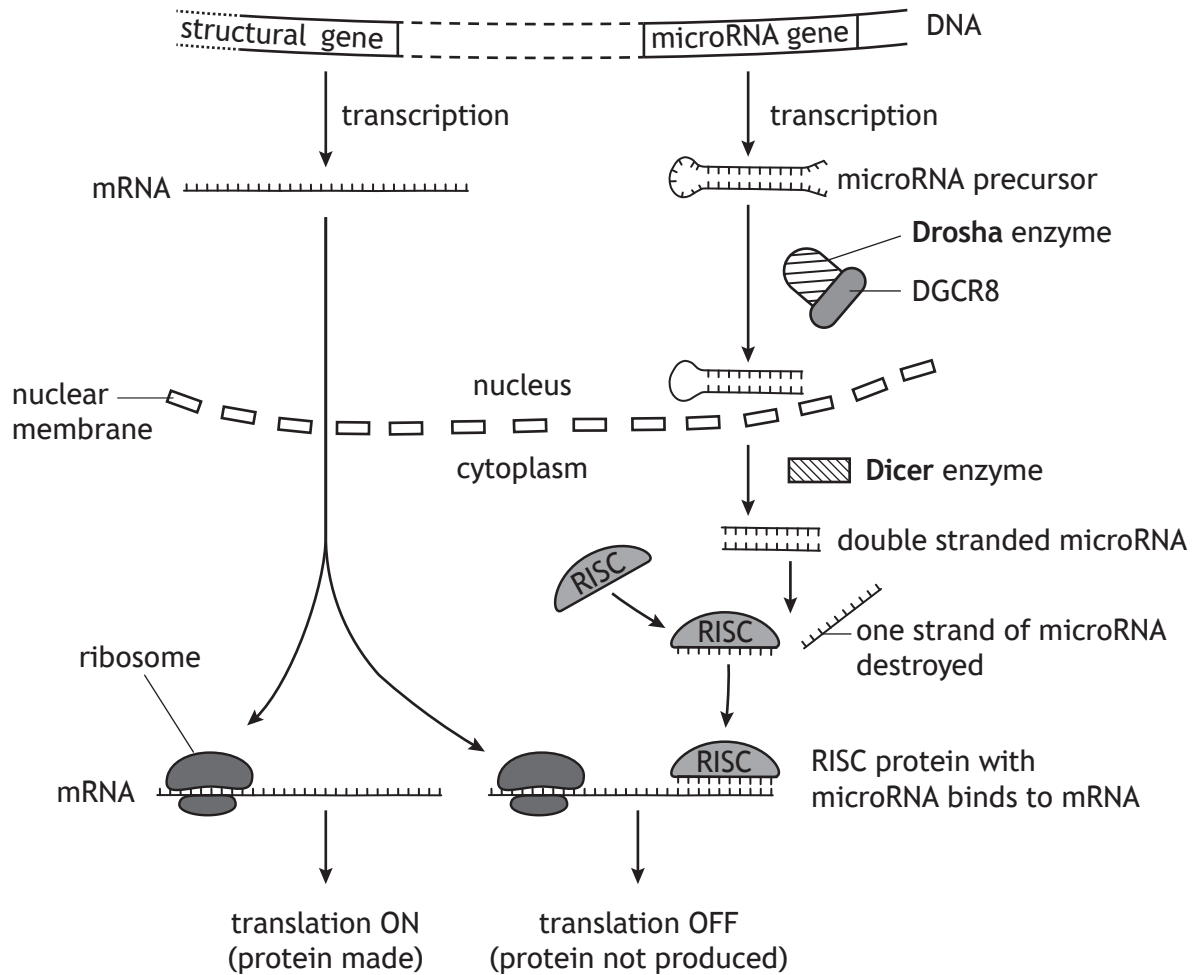

1. (continued)

Research has investigated the importance of microRNA in controlling the fate of stem cells. Stem cells can either divide rapidly to make more stem cells, a process called **self-renewal**, or differentiate into specialised cell types. To determine the role of microRNAs in these processes, stem cells were modified to 'knock out' microRNA production. These microRNA knockout cells lack the protein DGCR8, an activator of Drosha. **Figures 2A and 2B** compare growth rate and cell-cycle progression in knockout and normal cells.

In further work, the differentiation of knockout and normal cells was studied by inducing the cells to differentiate. Analysis was carried out on the levels of specific marker molecules whose presence is associated with either self-renewal or differentiation. Results are shown in **Figures 3A and 3B**.

Figure 2A Effect of knockout on growth rate

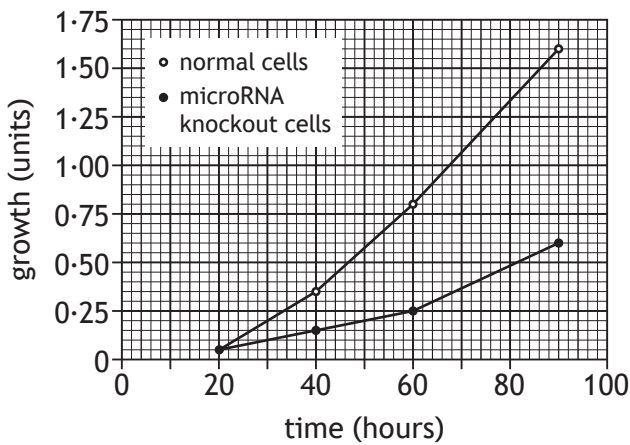

Figure 2B Effect of knockout on cell cycle

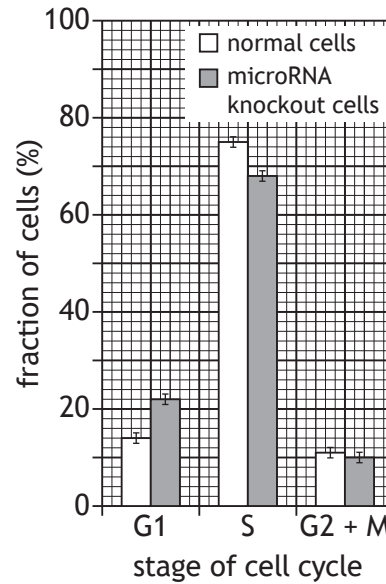

Figure 3A Level of self-renewal marker

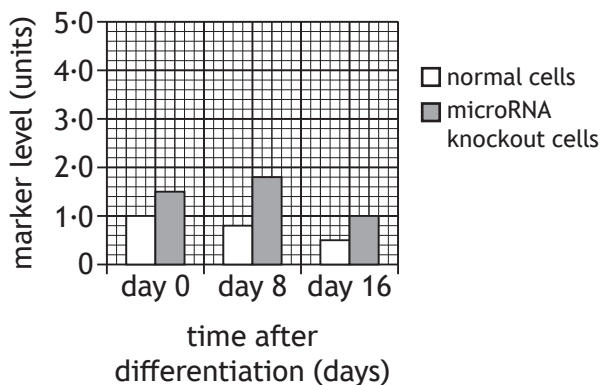
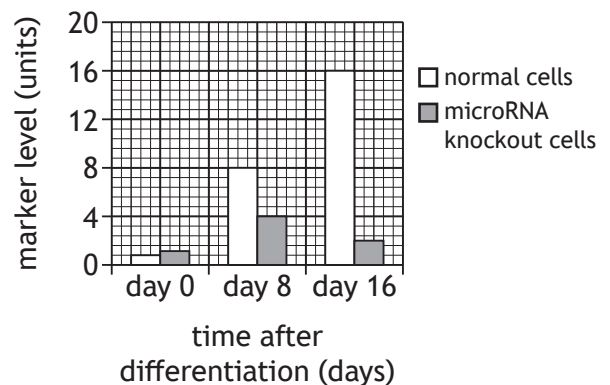

Figure 3B Level of differentiation marker



[END OF SUPPLEMENTARY SHEET]



National
Qualifications
SPECIMEN ONLY

S807/77/02

Biology

Marking Instructions

These marking instructions have been provided to show how SQA would mark this specimen question paper.

The information in this publication may be reproduced to support SQA qualifications only on a non-commercial basis. If it is reproduced, SQA should be clearly acknowledged as the source. If it is to be used for any other purpose, written permission must be obtained from permissions@sqa.org.uk.

Where the publication includes materials from sources other than SQA (ie secondary copyright), this material should only be reproduced for the purposes of examination or assessment. If it needs to be reproduced for any other purpose it is the user's responsibility to obtain the necessary copyright clearance.

General marking principles for Advanced Higher Biology

This information is provided to help you understand the general principles you must apply when marking candidate responses to questions in this paper. These principles must be read in conjunction with the detailed marking instructions, which identify the key features required in candidate responses.

- (a) Marks for each candidate response must **always** be assigned in line with these general marking principles and the detailed marking instructions for this assessment.
- (b) Marking should always be positive. Marks should be awarded for what is correct and not deducted for errors or omissions.
- (c) If a specific candidate response does not seem to be covered by either the principles or detailed marking instructions, and you are uncertain how to assess it, you should seek guidance from your Team Leader.
- (d) There are no half marks awarded.
- (e) Where a candidate makes an error in the first part of a question, credit should normally be given for subsequent answers that are correct with regard to this original error. Candidates should not be penalised more than once for the same error.
- (f) Unless a numerical question specifically requires evidence of working to be shown, full marks should be awarded for a correct final answer (including units) on its own.
- (g) Larger mark allocations may be fully accessed whether responses are provided in continuous prose, linked statements or a series of discrete developed points.
- (h) In the detailed marking instructions, if a word is **underlined** then it is essential; if a word is **(bracketed)** then it is not essential.
- (i) In the detailed marking instructions, words separated by / are alternatives.
- (j) A correct answer can be negated if:
 - an extra, incorrect, response is given;
 - additional information that contradicts the correct response is included.
- (k) Where the candidate is instructed to choose one question to answer but instead answers both questions, both responses should be marked and the better mark awarded.
- (l) The assessment is of skills, knowledge and understanding in Biology, so marks should be awarded for a valid response, even if the response is not presented in the format expected. For example, if the response is correct but is not presented in the table as requested, or if it is circled rather than underlined as requested, give the mark.
- (m) Unless otherwise required by the question, use of abbreviations (eg DNA, ATP) or chemical formulae (eg CO₂, H₂O) are acceptable alternatives to naming.
- (n) If a numerical answer is required and units are not given in the stem of the question or in the answer space, candidates must supply the units to gain the mark. If units are required on more than one occasion, candidates should not be penalised repeatedly.

- (o) Incorrect spelling is given. Sound out the word(s),
- if the correct word is recognisable then give the mark
 - if the word can easily be confused with another biological term then do not give the mark, eg ureter and urethra
 - if the word is a mixture of other biological terms then do not give the mark, eg mellum, melebrum, amniosynthesis.
- (p) Marks are awarded only for a valid response to the question asked. For example, in response to questions that ask candidates to:
- **identify, name, give, or state**, they need only name or present in brief form;
 - **describe**, they must provide a statement or structure of characteristics and/or features;
 - **explain**, they must relate cause and effect and/or make relationships between things clear;
 - **compare**, they must demonstrate knowledge and understanding of the similarities and/or differences between things;
 - **calculate**, they must determine a number from given facts, figures or information;
 - **predict**, they must suggest what may happen based on available information;
 - **evaluate**, they must make a judgement based on criteria;
 - **suggest**, they must apply their knowledge and understanding of Biology to a new situation. A number of responses are acceptable: marks will be awarded for any suggestions that are supported by knowledge and understanding of Biology;
 - **account for**, they must give a reason or reasons for a particular action, event, observation, change, or state.

Marking instructions for each question

SECTION 1

Question	Response	Mark
1.	A	1
2.	A	1
3.	C	1
4.	B	1
5.	A	1
6.	D	1
7.	B	1
8.	C	1
9.	C	1
10.	C	1
11.	C	1
12.	A	1
13.	C	1
14.	B	1
15.	D	1
16.	D	1
17.	B	1
18.	A	1
19.	D	1
20.	D	1

SECTION 2

Question		Expected response	Max mark	Additional guidance
1.	(a)	Proteome	1	
	(b)	<ul style="list-style-type: none"> • Drosha not working • miRNA/precursor not processed/cut • No (micro)RNA strand for RISC OR RISC can't bind (m)RNA • (RNA) interference reduced/translation is left on <p style="text-align: right;">Any 2</p>	2	
	(c)	(i) Cell growth/cell increases in mass	1	
		(ii) 62.5	1	
		(iii) More KO cells in G1 and fewer in S (and G2 + M) (1) Differences are likely to be significant (only) in G1 and S/error bars don't overlap in G1 and S OR If comparing only G1 bars or only S bars, then must point out significant difference (1)	2	Comparison can be made via data but data must be correct
	(d)	(i) (After induction of differentiation) <ul style="list-style-type: none"> • in KO cells it is (generally) lower than normal cells • it increases in normal cells (over time) • in KO cells + one from below <ul style="list-style-type: none"> — no trend — decreases from day 8 — increases (to day 8) then decreases (It = expression = level of marker) <p style="text-align: right;">Any 1</p>	1	
		(ii) <ul style="list-style-type: none"> • In normal cells, as differentiation increases self-renewal decreases OR converse (must link the two graphs/processes) • In KO/abnormal cells, both processes decrease after day 8 • in KO/abnormal cells, both processes increase to day 8 • in KO/abnormal cells, self-renewal remains higher and differentiation remains lower than normal <p style="text-align: right;">Any 2</p>	2	

Question			Expected response	Max mark	Additional guidance
2.	(a)	(i)	<p>1. Hydrophobic signalling molecules/cortisol/ it diffuses through the phospholipid bilayer of the cell membrane</p> <p>2. (So) binds to specific intracellular receptors/receptors in the cytosol or nucleus</p> <p>3. The receptors for hydrophobic signalling molecules/cortisol are transcription factors</p> <p>4. The hormone-receptor complex moves to the nucleus where it binds to hormone response elements/HREs/specific sites on DNA AND affects gene expression/ influences the rate of transcription</p> <p style="text-align: right;">Any 3</p>	3	
		(ii)	<p>(Different tissues will have) different responses to receptor binding</p> <p>OR</p> <p>(Different tissues will have) different signal transduction pathways</p> <p>OR</p> <p>Different genes switched off/on (in different tissues)</p> <p>OR</p> <p>There may be different cortisol receptors</p>	1	
	(b)		<p>Does not have Addison's;</p> <p>Patient 2 cortisol increases by 75 µg per litre at 30 min and increases by 125 µg per litre at 60 min</p>	1	<p>Accept:</p> <ul style="list-style-type: none"> • Patient 2 increases by 75 µg per litre at 30 mins and a further 50 µg per litre at 60 mins <p>With reference to between 30 and 60 mins</p> <ul style="list-style-type: none"> • range of 125–130 • range of 50–55 <p>Need: Correct units (µg per litre) at least once</p>

Question		Expected response	Max mark	Additional guidance
3.	(a)	<ul style="list-style-type: none"> GABA is a ligand/substance that can bind to protein The channel is a protein that opens in response to GABA/ligand binding Chloride passes through the protein when GABA is bound <p style="text-align: right;">Any 2</p>	2	
	(b)	Transduction	1	
	(c)	(i) Chloride movement is (generally) greater at any GABA concentration if drug present	1	
		(ii) Changes the conformation of the GABA site	1	
	(d)	Cell will become more negative inside (1) So membrane will be more difficult to depolarize (1)	2	

Question		Expected response	Max mark	Additional guidance
4.	(a)	Concentration of ATP solution	1	
	(b)	(i) Freshness of meat/whether meat has been frozen/temperature of storage/incubation time/time before measurement/thickness of strip Any 1	1	
		(ii) <ul style="list-style-type: none"> Storage of meat may cause damage to muscle proteins so muscle contraction would be less with less-fresh meat Freezing meat may damage muscle fibres so less contraction would be measured Freezing meat may preserve muscle proteins so more contraction would be measured As storage temperature increases protein damage may increase so less muscle contraction would be measured Increasing incubation time/time before measurement will give more time for ATP to diffuse so more muscle contraction would be measured ATP will diffuse more slowly through thicker strips which could mean the solution does not reach all the fibres so less contraction will be measured Any 1	1	Explanation of effect must match with chosen confounding variable
	(c)	Not reliable (1) No independent replication/whole experiment was only carried out once OR Only one measurement for each chop at each concentration of ATP (1)	2	
	(d)	Negative (control)	1	
	(e)	May have prevented a representative sample being selected	1	

Question		Expected response	Max mark	Additional guidance
5.	(a)	The training will have no effect on GLUT 4 content of muscle	1	
	(b)	ND UT is baseline GLUT 4 and training does not produce significant increase (1) D UT is (significantly) lower GLUT 4 than baseline and exercise generates significant increase (1)	2	
	(c)	Type 1 diabetes is failure to produce insulin whereas type 2 diabetes is loss of insulin receptor function/failure to respond to insulin	1	
6.	(a)	Retinal	1	
	(b)	1. (Photo) excited rhodopsin activates a G-protein, called transducing, (1) 2. which activates the enzyme phosphodiesterase (PDE) 3. PDE catalyses the hydrolysis of a molecule called cyclic GMP (cGMP) 4. This results in the closure of ion channels in the membrane of the rod cells, 5. which triggers nerve impulses in neurons in the retina (2) Any 2 from points 2–5 for 2 marks	3	
	(c)	Wide range of wavelengths absorbed/high degree of amplification from single photon	1	
7.	(a)	Phosphate added to either/both protein(s) so conformation(s) change	1	
	(b)	(p21 binding to Cdk) prevents Cdks phosphorylating proteins (1) (Proteins) that then stimulate the cell cycle OR unphosphorylated protein inhibits cycle/stops cycle at the checkpoint (1)	2	Need idea that unphosphorylated protein inhibits the cell cycle Rb = protein
	(c)	DNA damage OR death signals from lymphocytes	1	
	(d)	Apoptosis/programmed cell death / DNA damage repaired / cell continues through cell cycle	1	

Question		Expected response	Max mark	Additional guidance
8.		<p>Any 2 from:</p> <ul style="list-style-type: none"> • Cell division requires remodelling of cytoskeleton • Spindle fibres made of microtubules • (microtubules are) hollow/straight rods/cylinders/tubes • Composed of tubulin <p style="text-align: right;">Max 2 marks</p> <p>Any 2 from:</p> <ul style="list-style-type: none"> • Spindle microtubules extend from the MTOC by polymerization • Attach to chromosomes/chromatids/centromeres/kinetochores • via their kinetochores in the centromere region • as spindle microtubules shorten by depolymerisation, • sister chromatids are separated <p style="text-align: right;">Max 2 marks</p>	4	(extend= radiate/ grow/originate/made NOT grow from/made by centriole
9.	(a)	<p>Men have one allele of the haemophilia gene whereas women have two alleles (of the haemophilia gene) (1)</p> <p>Recessive allele causing haemophilia not masked in men (1)</p>	2	
	(b)	<p>Daughter 100 (1)</p> <p>Son 50 (1)</p>	2	
	(c)	(i) Prevents a double dose of gene products (coded by the X chromosome) that might disrupt cellular function	1	
		(ii) Inactivation of X chromosomes is random so this patient must have (by chance) more cells that have inactivated the unaffected allele/fewer cells that inactivated the affected allele	1	

Question			Expected response	Max mark	Additional guidance
10.	(a)	(i)	Does not itself actively transmit parasite to another species	1	
		(ii)	Waterborne dispersal stage	1	
	(b)		<ul style="list-style-type: none"> Mimic host antigens to evade detection Modify host immune response to reduce chances of destruction Antigenic variation allows rapid evolution to overcome host immune cell clonal selection <p style="text-align: right;">Any 1</p>	1	
	(c)		<ol style="list-style-type: none"> Co-evolution OR between species that interact frequently/closely Change in the traits of one species can act as a selection pressure on the other species Species in these relationships must adapt to avoid extinction <p style="text-align: right;">Any 2</p>	2	
11.	(a)		300	1	
	(b)	(i)	Reduction in abundance of named species due to increase in seal population/ physical damage/trampling (1) Increase in abundance of <i>Prasiola crista</i> due to reduced competition for space/greater tolerance of trampling (1)	2	
		(ii)	Loss of plants gives areas of bare rock OR Not all plant species counted	1	
	(c)	(i)	Carried out in a way that minimises impact on environment OR Consideration of rare/vulnerable species	1	
		(ii)	Population being sampled is split into sub-populations	1	

Question		Expected response	Max mark	Additional guidance
12.	(a)	At low courtship frequencies large males are chosen more often/have a higher probability of mating but this reverses at higher frequencies OR It changes from large males to small males as courtship rates increase	1	
	(b)	Latency	1	
	(c)	Sexual dimorphism	1	
	(d)	Less easy for predators to see them OR May be nesting/laying eggs OR Survival chances of the young increase	1	Not less predation
	(e)	Honest signals indicate favourable alleles in males (1) Offspring will (probably) inherit these favourable alleles so will be more likely to survive (1)	2	

Question			Expected response	Max mark	Additional guidance
13.	A	(i)	<ol style="list-style-type: none"> 1. Homologous chromosomes in diploid gametocyte 2. (Homologous chromosomes) have the same size/centromere position/genes at same loci 3. (Prior to meiosis) each chromosome consists of two chromatids attached at the centromere 4. Pairing of homologous chromosomes 5. Chiasmata form at points of contact between non-sister chromatids (of a homologous pair) 6. Crossing over occurs 7. Exchange of DNA between non-sister chromatids 8. (Crossing over) produces genetically different recombinant chromosomes 9. Homologous chromosome pairs line up randomly on equator/metaphase plate 10. Independent assortment 11. Separation of parental chromosomes irrespective of maternal and paternal origin <p style="text-align: right;">Any 8</p>	8	
		(ii)	<ol style="list-style-type: none"> a. (Two) cells produced in meiosis I undergo a further division b. Sister chromatids separate c. Randomly distributed to the daughter cells/gametes d. Four haploid gametes/cells produced <p style="text-align: right;">Any 2</p>	2	

Question			Expected response	Max mark	Additional guidance
13.	B	(i)	<ol style="list-style-type: none"> 1. Evolution is the change over time in the proportion of individuals in a population differing in one or more inherited traits 2. Mutation is the original source of new sequences of DNA/novel alleles 3. Results in new variation in traits/ phenotypes 4. Mutation can be harmful, neutral or beneficial 5. Beneficial mutations increase fitness 6. Individuals compete for limited resources <p>OR</p> <p>Populations produce more offspring than the environment can support</p> <ol style="list-style-type: none"> 7. Individuals with favourable alleles more likely to survive and reproduce/produce more offspring 8. Alleles conferring an advantage/favourable alleles more likely to be passed to next generation 9. Selection results in the non-random increase in the frequency of advantageous alleles <p>OR</p> <p>Non-random decrease in the frequency of deleterious alleles</p> <p style="text-align: right;">Any 6</p>	6	
		(ii)	<p>(rate of evolution increased by)</p> <ol style="list-style-type: none"> a. Strong selection pressures b. Selection pressures can be biotic or abiotic c. An example of a biotic factor from: <ul style="list-style-type: none"> • competition • predation • disease • parasitism d. An example of an abiotic factor from: <ul style="list-style-type: none"> • temperature • light intensity • humidity • pH • salinity e. Horizontal gene transfer <p style="text-align: right;">Any 4</p>	4	

[END OF SPECIMEN MARKING INSTRUCTIONS]