

CHEMISTRY

Higher Grade—PAPER I

Friday, 17th May—9.30 a.m. to 11.00 a.m.

READ CAREFULLY

1. Check that the answer sheet provided is for Chemistry Higher I.
2. Fill in the details required on the answer sheet.
3. In this paper a question is answered by indicating the choice A, B, C or D by a stroke made in INK in the appropriate place in the answer sheet— see the sample question below.
4. For each question there is only ONE correct answer.
5. Reference may be made to the booklets of Science Data and Mathematical Tables provided (1982 editions).
6. Rough working, if required, should be done only on this question paper, or on the rough working sheet provided—NOT on the answer sheet.

SAMPLE QUESTION

To show that the ink in a ball-pen consists of a mixture of dyes, the method of separation would be

- A fractional distillation
 B chromatography
 C fractional crystallisation
 D filtration.

The correct answer is B—chromatography. A **heavy** vertical line should be drawn joining the two dots in the appropriate box in the column headed **B** as shown on the answer sheet.

If after you have recorded your answer you decide that you have made an error and wish to make a change, you should cancel the original answer and put a vertical stroke in the box you now consider to be correct. Thus, if you want to change an answer **D** to an answer **B**, your answer sheet would look like this:

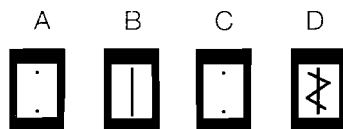

If you want to change back to an answer which has already been scored out, you should enter a tick (✓) to the **RIGHT** of the box of your choice, thus:

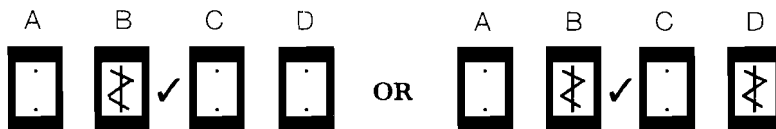

1. Different isotopes of the same element have identical
- nuclei
 - electron arrangements
 - numbers of neutrons
 - mass numbers.

2.

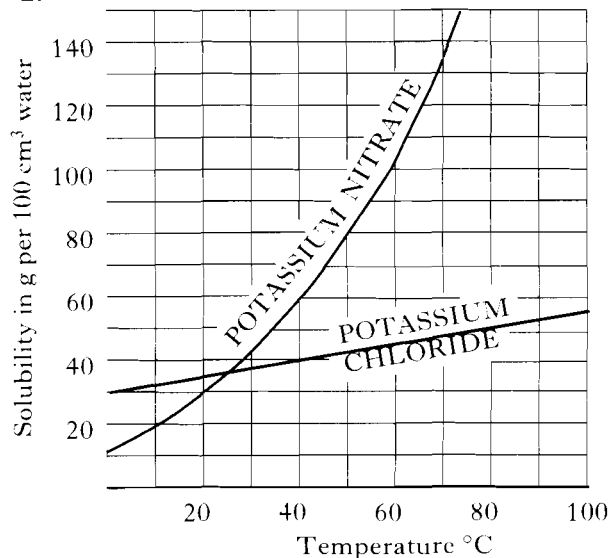

50 g potassium nitrate and 50 g potassium chloride are dissolved separately, each in 100 cm³ of boiling water. The solutions are cooled to 40°C. From the information in the above graph, decide which of the following is likely to happen.

- No crystals form.
 - Crystals of potassium nitrate form.
 - Crystals of potassium chloride form.
 - Crystals of **both** substances form.
3. 56 g of an oxide of lead was strongly heated and hydrogen gas was passed over it. When the oxide was completely reduced, 52 g of lead remained. A possible formula for the oxide is
- Pb₂O₃
 - PbO₂
 - Pb₂O
 - PbO

4. A mixture of magnesium bromide and magnesium sulphate is known to contain 3 moles of magnesium and 4 moles of bromide ions. How many moles of sulphate ions are present?
- 1
 - 2
 - 3
 - 4

5. When a gas was burned in air, the products formed gave a white precipitate with calcium hydroxide solution (lime water) and turned anhydrous copper(II) sulphate blue. Which of the following gases could it have been?
- Methane
 - Carbon monoxide
 - Hydrogen
 - Ammonia
6. The formation of carbon from starch is an example of
- condensation
 - hydration
 - hydrolysis
 - dehydration.
7. Which of the processes outlined below is most likely to be used in the large-scale production of calcium?
- Electrolysis of an aqueous solution of calcium chloride
 - Heating a mixture of carbon and calcium oxide
 - Electrolysis of molten calcium chloride
 - Addition of magnesium to an aqueous solution of calcium chloride

8. 64 g of copper is added to 1 litre of 1.0 M silver nitrate solution. Which of the following statements represents one of the results of this action?
- A The resulting solution is colourless.
 - B All the copper dissolves.
 - C 64 g of silver is formed.
 - D 1 mole of silver is formed.

9. Dilute sulphuric acid (2M) is dropped on to a mixture of magnesium and magnesium carbonate. Which of the following would be the most likely composition of the gas evolved?
- A Carbon dioxide only
 - B Hydrogen only
 - C Hydrogen and carbon dioxide
 - D Carbon dioxide and sulphur dioxide

Questions 10 and 11 refer to equal volumes of the following molar solutions.

- A Sodium iodide
- B Hydrochloric acid
- C Sodium hydroxide
- D Ethanoic acid

10. Which solution is the best conductor of electricity?
11. Which solution contains the fewest ions?
12. A solution of potassium carbonate, made up using tap water, was found to be cloudy. This could result from the tap water containing
- A sodium ions
 - B chloride ions
 - C magnesium ions
 - D sulphate ions.

13. Concentrated aqueous solutions of the following are electrolysed, using carbon electrodes. Which electrolysis is **least** likely to involve the chemical breakdown of water?
- A Copper (II) bromide
 - B Copper (II) sulphate
 - C Sodium bromide
 - D Sodium sulphate

14. Which of the following statements is true for an aqueous solution of sulphur dioxide?
- A It turns pH indicator blue.
 - B It is completely ionised.
 - C It contains more hydrogen ions than hydroxyl ions.
 - D It reacts with alkalis producing sulphur dioxide gas.

Questions 15 and 16 refer to the following properties of sulphuric acid.

- A An involatile acid
- B An oxidising agent
- C A typical acid
- D A dehydrating agent

Which property is shown in the following reactions?

15. Production of nitric acid by the reaction of concentrated sulphuric acid on potassium nitrate.
16. Reaction of copper metal with hot, concentrated sulphuric acid.
17. Sparks were passed for several minutes between electrodes placed in a flask filled with an unknown gas or gases. When sparking was stopped, a little water was added and shaken up with the contents of the flask. A small piece of magnesium metal was then added and brisk effervescence took place.

Initially, the flask could have contained

- A hydrogen and oxygen
- B nitrogen and hydrogen
- C ammonia
- D air.

18.

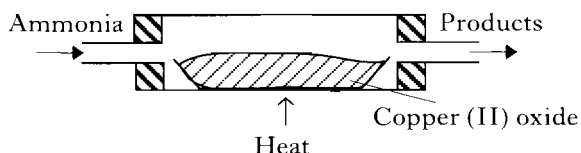

The gaseous products in the above reaction are

- A nitrogen and oxygen
- B nitrogen dioxide and hydrogen
- C nitrogen oxide (nitrogen monoxide) and steam
- D nitrogen and steam.

19. When copper is added to moderately concentrated nitric acid, a colourless gas is produced. The gas is

- A nitrogen
- B nitrogen oxide (nitrogen monoxide)
- C nitrogen dioxide
- D hydrogen.

20. The reaction between aqueous sodium hydroxide and the compound

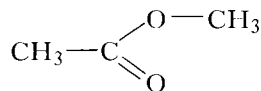

is an example of

- A addition
- B hydrolysis
- C dehydration
- D substitution.

21. When a substance is heated with soda-lime, it releases ammonia. When burned, it produces carbon dioxide and water vapour. **From this evidence alone**, which of the following is the most precise description you may make of the substance?

- A A nitrogen compound
- B An organic nitrogen compound
- C A compound built up from amino acids
- D A protein

Questions 22 and 23 refer to the following four classes of polymers.

- A Natural addition polymer
- B Natural condensation polymer
- C Synthetic addition polymer
- D Synthetic condensation polymer

Place each of the following in its appropriate class.

22.

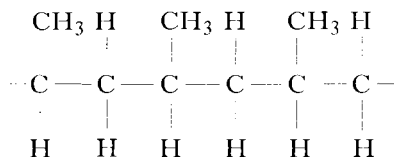

23. Cellulose

24. In the diagram below, each sphere represents a particle about the size of an atom and the sign indicates the charge on the particle.

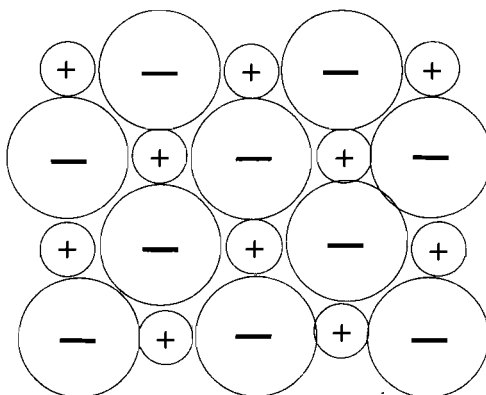

For which one of the following substances would the above model be a reasonable representation of the particles and the way they are arranged in the crystal?

- A Lithium bromide
- B Calcium fluoride
- C Tetrabromomethane
- D Diamond

25. Which of the following general methods for making salts can best be used to prepare lead(II) carbonate?
- Metal + dilute acid
 - Metal oxide + acid
 - Alkali + acid
 - Precipitation
26. A pupil found that, on neutralising 50 cm³ of lithium hydroxide solution with 2M hydrochloric acid, the final volume of the mixture was 110 cm³. Which of the following statements is true?
- 10 cm³ of water was formed during the reaction.
 - The final solution had a pH greater than 7.
 - The lithium hydroxide solution was more concentrated than the acid.
 - The final volume was about 100 cm³ after the salt formed had been filtered off.
27. Chlorine has isotopes $^{35}_{17}\text{Cl}$ and $^{37}_{17}\text{Cl}$. If chlorine molecules are analysed in a mass spectrometer, how many different molecular masses will be detected?
- 1
 - 2
 - 3
 - 4
28. When some zinc pellets containing radioactive zinc are placed in a solution of zinc chloride, radioactivity soon appears in the solution. Compared with that of the pellets, the half-life of the radioactive solution will be
- shorter
 - the same
 - longer
 - dependent upon how long the zinc is in contact with the solution.
29. Radioactive $^{14}_6\text{C}$ decays by beta-particle emission. Which statement is true of the new nucleus produced?
- It has mass number 13.
 - It has 6 protons.
 - It has 7 neutrons.
 - It is a carbon nucleus.
30. In the electrolysis of a solution of copper(II) sulphate using copper electrodes, the passage of one faraday of electricity (96,500 coulombs) results in the positive electrode
- gaining 64 g mass
 - losing 64 g mass
 - gaining 32 g mass
 - losing 32 g mass.
31. Which of the following gases at the same temperature and pressure contains the **smallest** number of molecules?
- 100 g oxygen
 - 100 g ammonia
 - 100 g fluorine
 - 100 g sulphur dioxide
32. How many atoms will be present in 11.2 litres of gaseous fluorine at s.t.p?
- 1.5×10^{23}
 - 3×10^{23}
 - 6×10^{23}
 - 1.2×10^{24}
33. 20 cm³ of 0.3M sodium hydroxide solution can be exactly neutralised by
- 20 cm³ 0.3M sulphuric acid
 - 20 cm³ 0.6M sulphuric acid
 - 10 cm³ 0.6M sulphuric acid
 - 10 cm³ 0.3M sulphuric acid.

34. The following table shows the standard reduction potentials (E°) for three half cells.

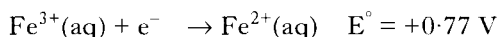
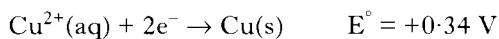
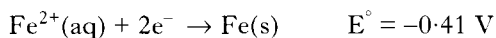

From a study of these values, it is reasonable to expect that when copper metal is put into a solution containing a mixture of iron(III) and iron(II) ions

- A a precipitate of iron will be formed
- B no reaction will take place
- C iron(II) ions will be oxidised to iron(III) ions
- D copper will be oxidised to copper(II) ions.

35. When an atom reacts to become an ion X^-

- A the diameter of the particle increases
- B the nucleus of X acquires a negative charge
- C the atomic number of X increases
- D the number of electron shells increases by 1.

Questions 36 and 37 refer to the following list of bonding types.

- A Ionic
- B Metallic
- C Covalent, discrete molecules
- D Covalent, network solid

Choose the **main** type of bonding present in each of the following.

36. A substance which melts at 843°C and boils at 1540°C . The molten substance conducts electricity, but no chemical change occurs.

37. A substance which melts at 1074°C and boils at 1740°C . The passage of an electric current through the molten substance results in electrolysis.

38. From the information given below, which of the following elements is most likely to form an ion of the type X^{2+} ?

	1st Ionisation Energy kJ mol^{-1}	2nd Ionisation Energy kJ mol^{-1}	3rd Ionisation Energy kJ mol^{-1}
A	1690	3380	6060
B	500	4560	6920
C	600	1160	4930
D	580	1830	2760

39. In which case is hydrogen gas acting as an oxidising agent?

- A $\text{H}_2 + \text{CuO} \rightarrow \text{H}_2\text{O} + \text{Cu}$
- B $\text{H}_2 + \text{C}_2\text{H}_4 \rightarrow \text{C}_2\text{H}_6$
- C $\text{H}_2 + \text{Cl}_2 \rightarrow 2\text{HCl}$
- D $\text{H}_2 + 2\text{Na} \rightarrow 2\text{NaH}$

40. Which of the following would produce a blue-black colour when added to a solution containing starch and potassium iodide?

- A Bromine water
- B Dilute sulphuric acid
- C Sodium hydroxide solution
- D Iron(II) sulphate solution

41. As the relative atomic mass in the halogens increases

- A the ionic radius decreases
- B the density decreases
- C the first ionisation energy increases
- D the boiling point increases.

42. An excess of 2M hydrochloric acid is added to one of two identical samples of calcium carbonate and an excess of 1M hydrochloric acid is added to the other. All other conditions are the same. Which of the following is the same for the two reactions?

- A The initial reaction rate
- B The total time for the reaction
- C The total mass lost
- D The average rate of evolution of gas

43. The decomposition of magnesium carbonate by heat can be prevented from going to completion by
- A absorbing the carbon dioxide produced
 - B removing magnesium oxide as it is formed
 - C carrying out the reaction in a small, closed container
 - D reducing the pressure.

44. A pH value greater than 7 would be shown by a 1.0 M solution of
- A sodium sulphate
 - B ammonium chloride
 - C potassium ethanoate
 - D lithium chloride.

45. Hydrogen and iodine at 500 °C react according to the equation

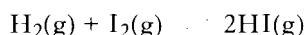

Vessel X contains 1 mole H_2 + 1 mole I_2 .

Vessel Y contains 2 moles HI.

X and Y are left at 500 °C until no further change occurs.

Which statement is true?

- A X will contain more hydrogen than Y.
- B X will contain less iodine than Y.
- C X and Y will contain the same amount of HI(g).
- D Y will contain 1 mole of $\text{I}_2(\text{g})$.

46. The number of structural isomers having the molecular formula C_5H_{12} is
- A 2
 - B 3
 - C 4
 - D 5

Questions 47 and 48 refer to the following hydrocarbons which all contain six carbon atoms per molecule.

- A Benzene
 - B Hexane
 - C Hex-1-ene
 - D Cyclohexene
47. Which of these compounds has carbon to carbon bonds all of the same length and always gives the same product when one of its hydrogen atoms is replaced by a chlorine atom?
48. Which of these compounds can be synthesised by an addition reaction involving three molecules of ethyne per molecule of product?

49. Which of the following compounds would liberate one mole of hydrogen gas when one mole of it reacts with two moles of sodium?
- A $\text{C}_2\text{H}_5\text{OH}$
 - B $\text{CH}_2\text{OHCH}_2\text{OH}$
 - C CH_3COOH
 - D CH_3CHO

50. A white crystalline compound, soluble in water, reacts with both dilute hydrochloric acid and sodium hydroxide solution. Which of the following could it be?



- B $\text{H}_2\text{NCH}_2\text{COOH}$
- C $\text{C}_2\text{H}_5\text{NH}_2$
- D $\text{C}_2\text{H}_5\text{NH}_3\text{Cl}$

[END OF QUESTION PAPER]

[0519/315]

1991

SCOTTISH CERTIFICATE OF EDUCATION

CHEMISTRY

Higher Grade—PAPER II

Friday, 17th May—1.30 p.m. to 4.00 p.m.

Candidates are reminded that 4 marks are allocated for communication skills, assessed mainly in Part B of this paper.

Working should be shown in all answers involving calculations.

Necessary tables and data will be found in the booklets of Mathematical Tables and Science Data (1982 editions).

All questions should be attempted. It should be noted, however, that questions 2 and 3 contain a choice.

It is suggested that about $1\frac{1}{4}$ hours be spent on this part of the paper.

Marks

1. In each of the following cases, choose which ion would be deflected most in a mass spectrometer and give the reason for your choice.

(a) $^{35}\text{Cl}^+$ and $^{37}\text{Cl}^+$

1

(b) $^{35}\text{Cl}^+$ and $^{35}\text{Cl}^{2+}$

1

(2)

2. Answer **EITHER A OR B**

A. An 8 g sample of $^{24}_{11}\text{Na}$ undergoes β -decay to form a stable product as shown in the graph below:

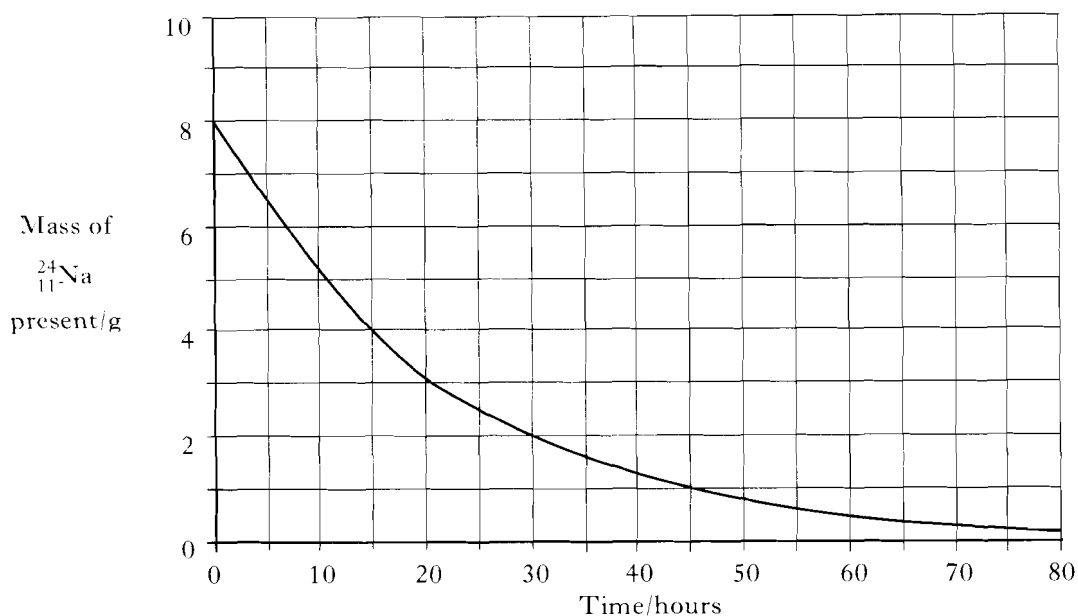

(a) Write a nuclear equation for the decay of $^{24}_{11}\text{Na}$.

1

(b) From the graph, what is the half-life of $^{24}_{11}\text{Na}$?

1

(c) What mass of **product** would be formed from the sample after 45 hours?

1

(3)

OR

B. (a) ${}^{239}_{92}\text{U}$ can be made by bombarding ${}^{238}_{92}\text{U}$ with neutrons.

Write a nuclear equation for this reaction.

1

(b) The following diagram shows the ${}^{239}_{92}\text{U}$ radioactive decay series:

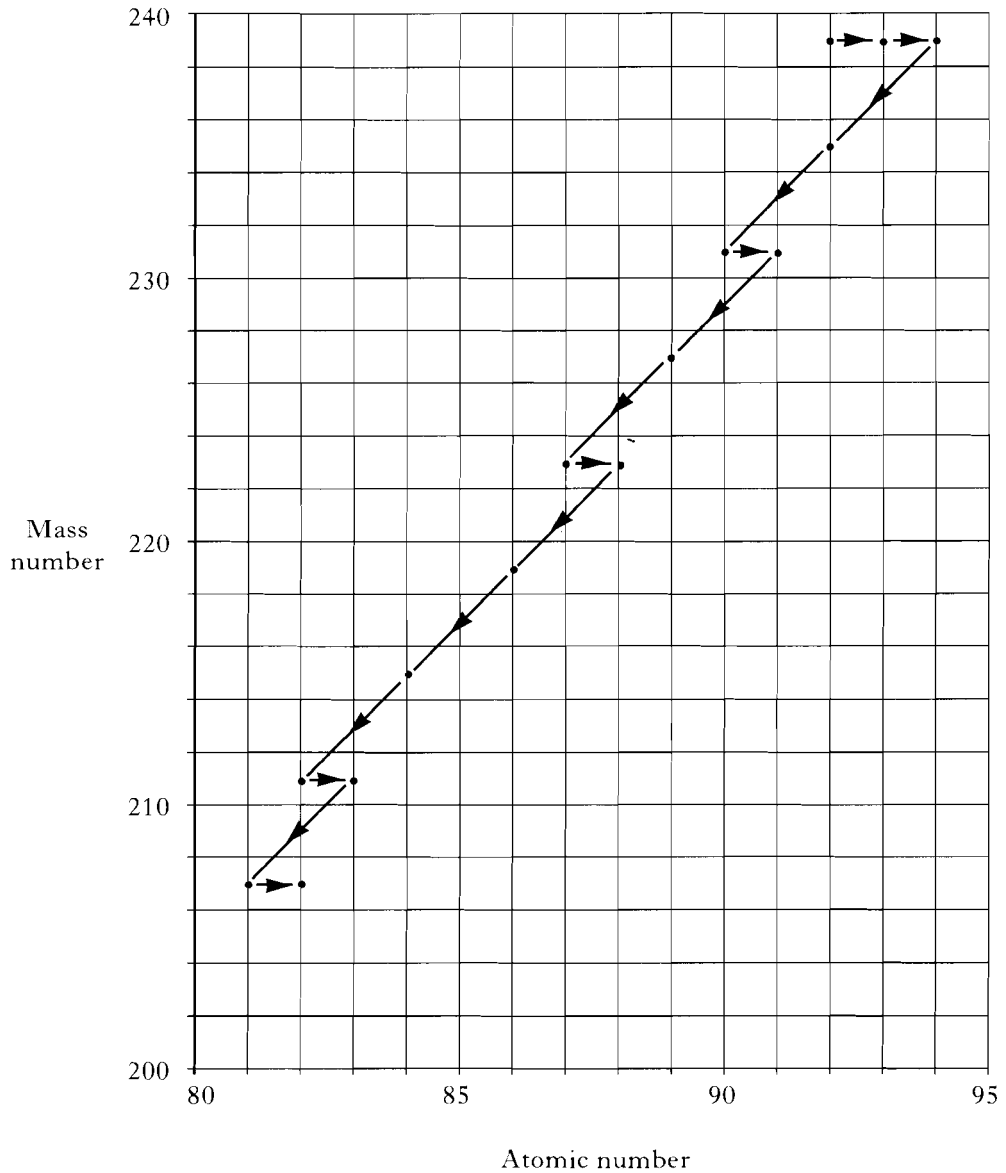

Use this information to find the total number of

- (i) α -emissions;
- (ii) β -emissions occurring.

2
(3)

[Turn over

3. Answer **EITHER A OR B**.

A. Calculate the number of moles of aluminium oxide which contains 3×10^{23} ions. (3)

OR

B. Given 4 g of methane gas, calculate the number of

- (a) moles; 1
 (b) molecules; 1
 (c) atoms present in the sample. (3)

4. (a) Copy and balance the equation below:

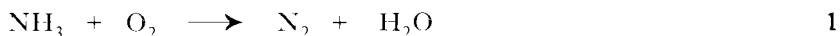

(b) Calculate the volume of oxygen required to burn 200 cm^3 of ammonia gas, according to your balanced equation in (a) (both volumes being measured under the same conditions of temperature and pressure). 1

(c) Name the products obtained if ammonia is oxidised in the presence of a platinum catalyst. 1
 (3)

5. Consider the following reactions:

	Reaction	$\Delta H / \text{kJ mol}^{-1}$
P	$\text{C(s)} \longrightarrow \text{C(g)}$	+715
Q	$\text{C}_3\text{H}_8\text{(g)} + 5\text{O}_2\text{(g)} \longrightarrow 3\text{CO}_2\text{(g)} + 4\text{H}_2\text{O(l)}$	-2220
R	$3\text{C(s)} + 4\text{H}_2\text{(g)} \longrightarrow \text{C}_3\text{H}_8\text{(g)}$	-104

(a) Name enthalpy change R. 1

(b) Select information from the above table to calculate the enthalpy change for the reaction:

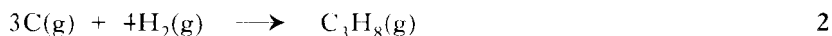

(c) Use information from the table to calculate the enthalpy change during the complete combustion of 1120 cm^3 of propane (measured at s.t.p.). 2
 (5)

6. Consider the substances shown in the table below.

sodium hydride	ethanol	diamond
carbon monoxide	neon	hydrogen
methane	copper	water

From the above table, choose **two** substances in each case which:

- (a) conduct electricity when molten; 1
 (b) have hydrogen bonding between their molecules; 1
 (c) are gaseous at room temperature but whose molecules are **not** diatomic. 1
 (3)

7. The oxidation of iodide ions to iodine by acidified hydrogen peroxide (H_2O_2) can be studied in the cell shown:

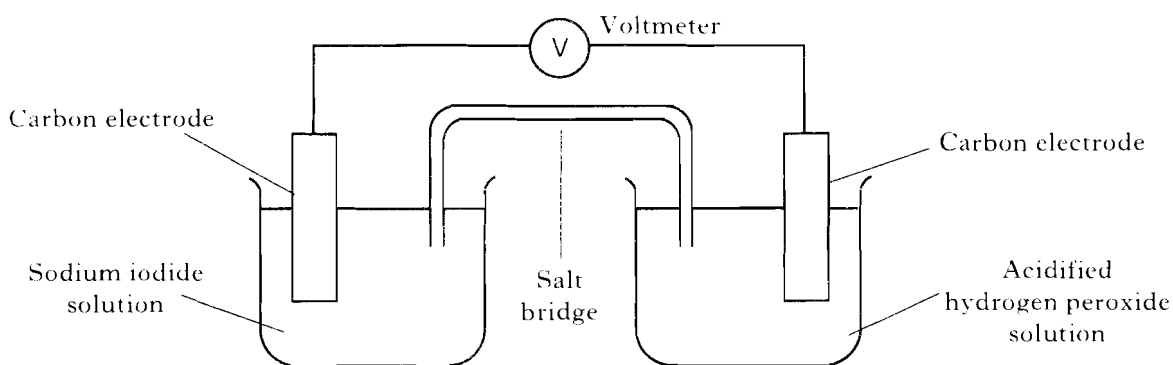

- (a) Given that:



use the Data Booklet to predict the voltage of the above cell.

- (b) What assumption is made about the concentrations of the solutions in calculating this voltage? 1
- (c) Write a balanced equation for the overall redox reaction. 1
- (d) In which direction would electrons flow in the external circuit? 1
- (e) Why would sodium chloride solution be unsuitable in the salt bridge? 1

(5)

8. The reaction between hydrogen and chlorine is explosive:

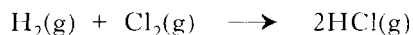

It is thought to take place in three stages as follows:

- (1) Initiation
 $\frac{1}{2}\text{Cl}_2(\text{g}) \longrightarrow \text{Cl}\cdot(\text{g}) \quad \Delta H = +121.5\text{kJ}$
- (2) Propagation
 $\text{H}_2(\text{g}) + \text{Cl}\cdot(\text{g}) \longrightarrow \text{HCl}(\text{g}) + \text{H}\cdot(\text{g}) \quad \Delta H = +5.0\text{kJ}$
- (3) Termination
 $\text{H}\cdot(\text{g}) + \text{Cl}\cdot(\text{g}) \longrightarrow \text{HCl}(\text{g}) \quad \Delta H = -431.0\text{kJ}$

- (a) In this reaction, what normally provides the activation energy for stage (1)? 1
- (b) **Explain** which of the stages above is most likely to be the rate-determining step in the reaction. 1
- (c) Another reaction also takes place in the propagation stage. Write an equation for this. 1
- (d) What name is given to explosive reactions of this type? 1

(4)

[Turn over

9. Consider the energy diagram:

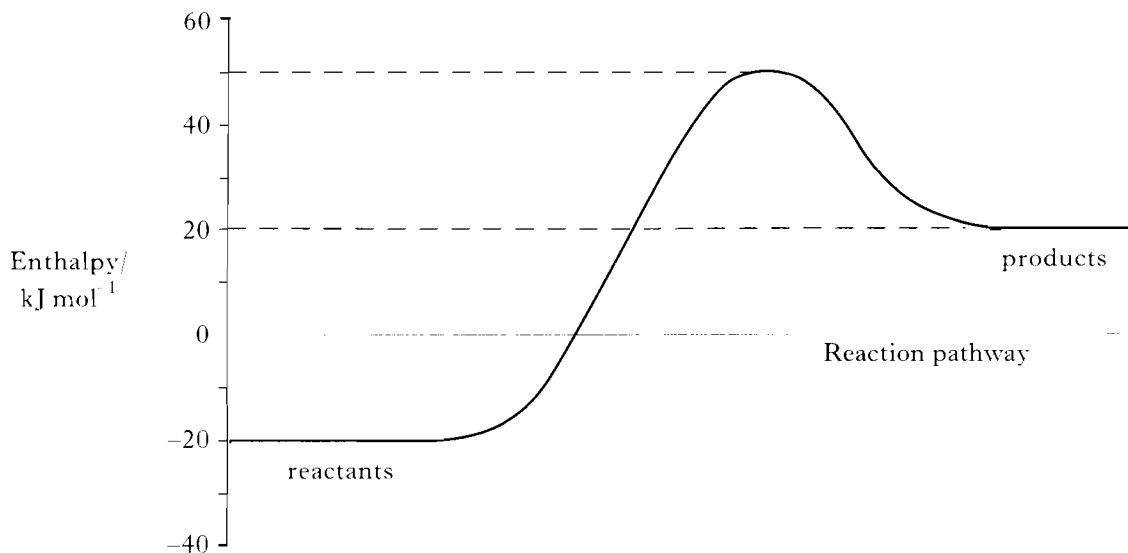

- (a) From the diagram, find values for
- (i) the enthalpy change and the activation energy of the forward reaction; 1
 - (ii) the enthalpy change and the activation energy of the reverse reaction. 1
- (b) Which, if any, of the above values would be altered by the use of a catalyst? 1
- (3)**

10. Consider the following equilibrium:

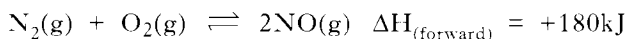

How would the equilibrium concentration of nitrogen oxide be affected by:

- (a) increasing the temperature; 1
 - (b) decreasing the pressure; 1
 - (c) decreasing the concentration of oxygen? 1
- (3)**

11. Consider the functional groups shown in boxes A to F.

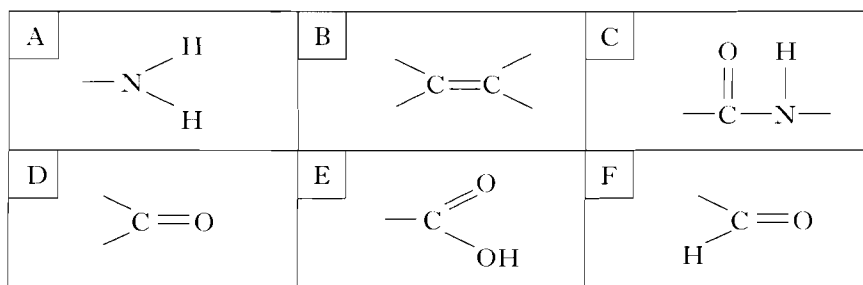

Answer the questions which follow by giving the **box reference letter**.

- (a) Which box contains a functional group that gives a positive test with ammoniacal silver nitrate solution ('Tollens' reagent)? 1
 - (b) Which **two** boxes contain functional groups present in compounds formed by the complete hydrolysis of proteins? 2
- (3)**

12. The compound C_2H_2 can be used to make various plastics:

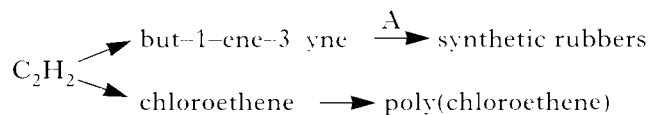

- (a) To which homologous series does C_2H_2 belong? 1
- (b) Draw the structure of but-1-ene-3-yne. 1
- (c) Which type of polymerisation occurs in reaction A? 1
- (d) Draw the structure of part of poly(chloroethene) showing at least three monomer units linked together. 1
- (4)**

13. Consider the following reaction sequence:

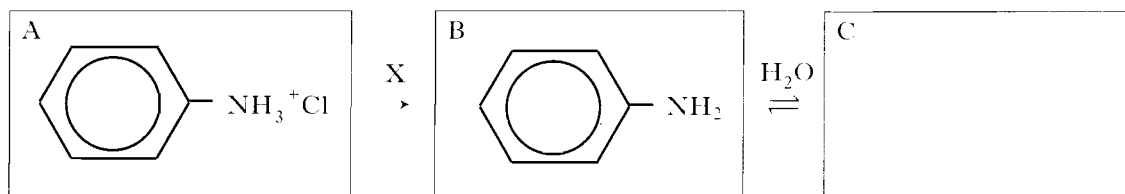

- (a) Name reagent X. 1
- (b) Name compound B. 1
- (c) Using a diagram similar to A and B, indicate the structure of compound C. 1
- (3)**

14. Consider the following diagrams, one of which represents part of the sodium chloride lattice, the other, part of the caesium chloride lattice.

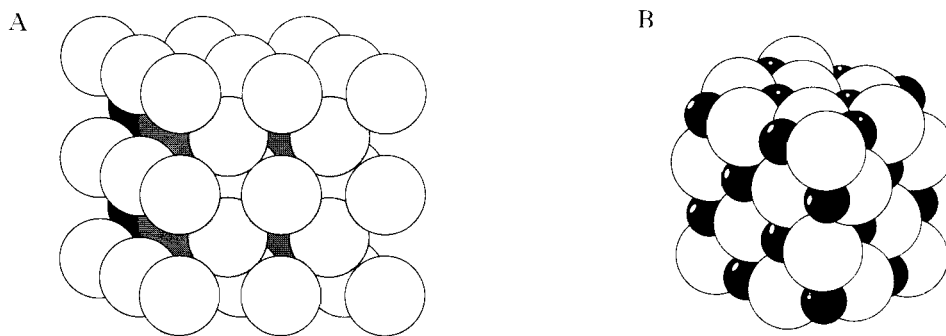

- (a) Which diagram illustrates the structure of sodium chloride? 1
- (b) In which way do these two lattice structures differ? 1
- (c) Show, by calculation, whether the lithium fluoride lattice is more likely to resemble that of sodium chloride or that of caesium chloride. (Data Booklet, page 5) 2
- (4)**

[Turn over

All four questions should be attempted. It should be noted, however, that question 18 contains a choice.

Candidates are advised to spend about $1\frac{1}{4}$ hours on this part of the paper.

15. Sodium thiosulphate solution, $\text{Na}_2\text{S}_2\text{O}_3(\text{aq})$, reacts with hydrochloric acid to produce a suspension of sulphur according to the ionic equation:

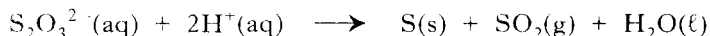

The rate of this reaction can be determined from the time it takes for the sulphur formed to obscure a cross marked on a sheet of paper underneath the reaction vessel:

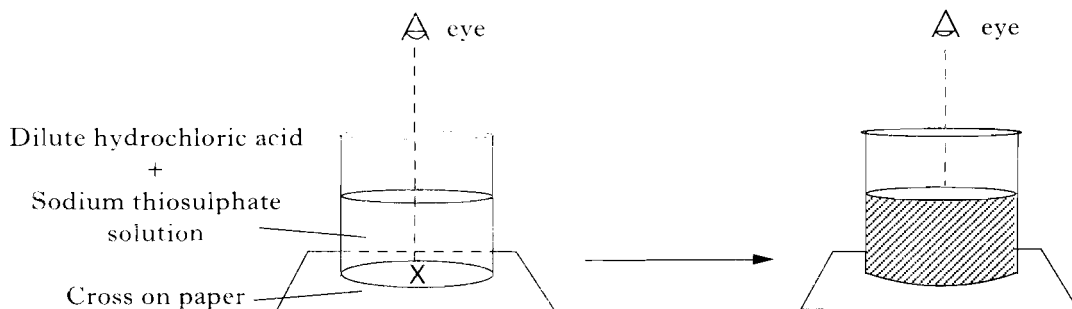

A pupil carried out a series of experiments to study the effect of the concentration of thiosulphate solution on the rate of reaction and obtained the following results.

	<i>Volume of $\text{Na}_2\text{S}_2\text{O}_3(\text{aq})$ used/cm^3</i>	<i>Volume of water added/cm^3</i>	<i>Relative concentration of $\text{Na}_2\text{S}_2\text{O}_3(\text{aq})$</i>	<i>Volume of $\text{HCl}(\text{aq})$ added/cm^3</i>	<i>Time (t) for X to vanish/s</i>	<i>Rate (1/t) s^{-1}</i>
Expt. A	50	0	5	10	10.0	0.10
Expt. B	40	10	4	10	12.5	0.08
Expt. C	30	20	3	10	16.7	0.06
Expt. D	20	30	2	10	33.3	0.03
Expt. E	10	40	1	10	50.0	0.02

A graph of rate against relative concentration of $\text{Na}_2\text{S}_2\text{O}_3(\text{aq})$ produced the following:

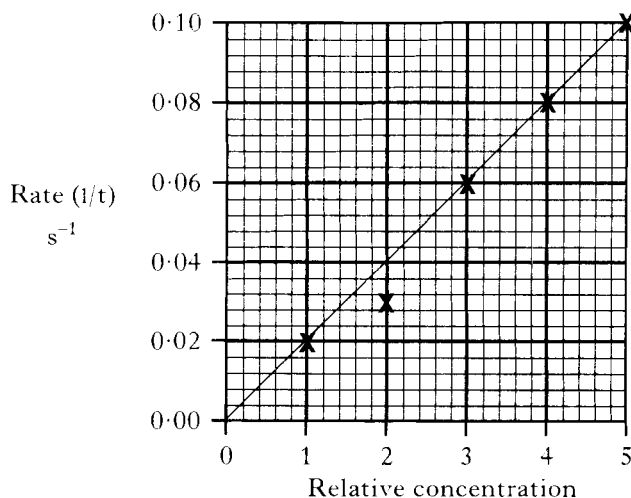

15. (continued)

- (a) From **the first two columns of the results table**, which factor is being kept constant throughout the series of experiments? 1
- (b) (i) From the graph, what conclusion can be drawn concerning the concentration of the thiosulphate solution and the reaction rate? 1
(ii) Explain, on theoretical grounds, why changing the concentration affects the reaction rate. 1
- (c) The graph suggests that the time recorded for **one** of the experiments in the table is wrong. Assuming the other points on the graph are correct, calculate the **expected** time for X to vanish in this particular experiment. 2
- (d) Suggest two **other** ways of increasing the rate of the reaction in these experiments. 2
- (e) In another experiment, the pupil investigated the rate of the reaction between chalk and hydrochloric acid by measuring the volume of gas given off over a period of time.



- (i) Draw a diagram of apparatus which might have been used in this investigation. 2
- (ii) Sketch the graph (no graph paper required) which the pupil would have obtained in this experiment. (Label the axes.) 2
- (iii) The pupil considered investigating the thiosulphate/acid reaction by this method. Give a reason why it would be unlikely to be successful in this case. 1
- (12)**

[Turn over

16. In the flow diagram, compound A is converted into a mixture of B and D, which are in turn converted into other products as shown.

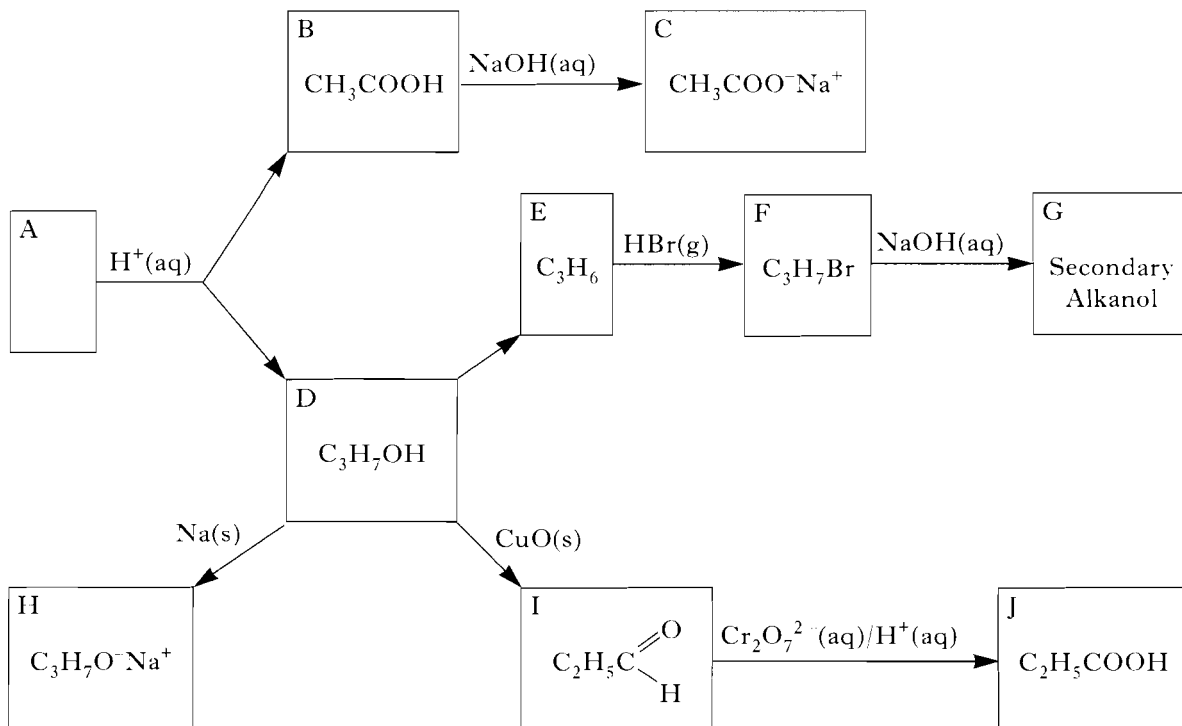

- (a) Write the full structural formulae for compounds A and F. 2
- (b) Name compound G. 1
- (c) Which **two** compounds are isomeric? 1
- (d) State the type of reaction which converts compound D to I. 1
- (e) Name a reagent capable of converting compound D to E. 1
- (f) What would be observed during the conversion of
- compound D to H;
 - compound I to J? 2
- (g) Explain why an aqueous solution of compound C is alkaline. 2
- (h) In the conversion of B to C, calculate the mass of solid sodium hydroxide necessary to neutralise 20 cm^3 of a 0.5 M aqueous solution of compound B. 2

(12)

17. (a) Consider the following simplified mass spectrum of the element rubidium. (The relative intensities of the two main peaks are shown as percentages.)

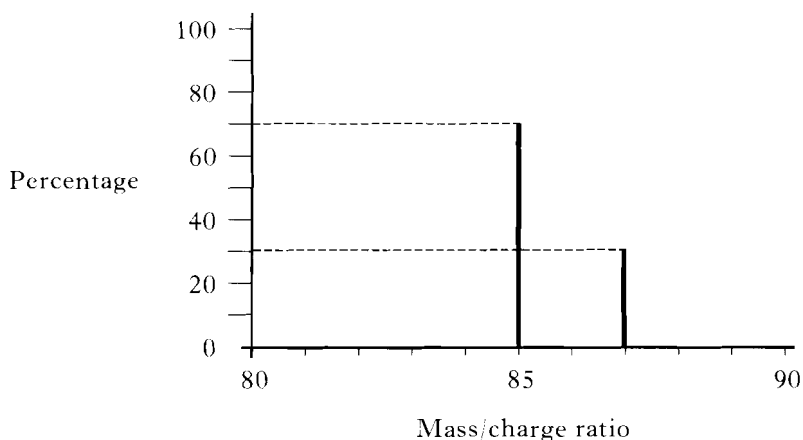

From this mass spectrum, the relative atomic mass of rubidium can be calculated.

- (i) What is meant by the term “relative atomic mass”? 1
- (ii) What is the significance of the mass spectrum having **two** main peaks? 1
- (iii) Calculate the relative atomic mass of rubidium correct to 1 decimal place. 2
- (b) (i) Write a balanced equation for the reaction between rubidium and water. 1
- (ii) How would you expect the rate of this reaction to compare with that between potassium and water? 1
- (c) Suggest a naturally occurring source of rubidium compounds. 1
- (d) Write the equation which represents the first ionisation energy of rubidium. 1
- (e) Refer to the Data Booklet and **explain** the difference in values between the first ionisation energy of rubidium and
- (i) the first ionisation energy of potassium;
- (ii) the first ionisation energy of strontium;
- (iii) the **second** ionisation energy of rubidium. 3
- (f) Why would you expect rubidium fluoride to be the most ionic of the rubidium halides? 1
- (12)**

[Turn over

18. Answer EITHER A OR B

A. Silicon occurs naturally as silicon dioxide, SiO_2 , in sand and quartz. The extraction of silicon is outlined in the following flow chart.

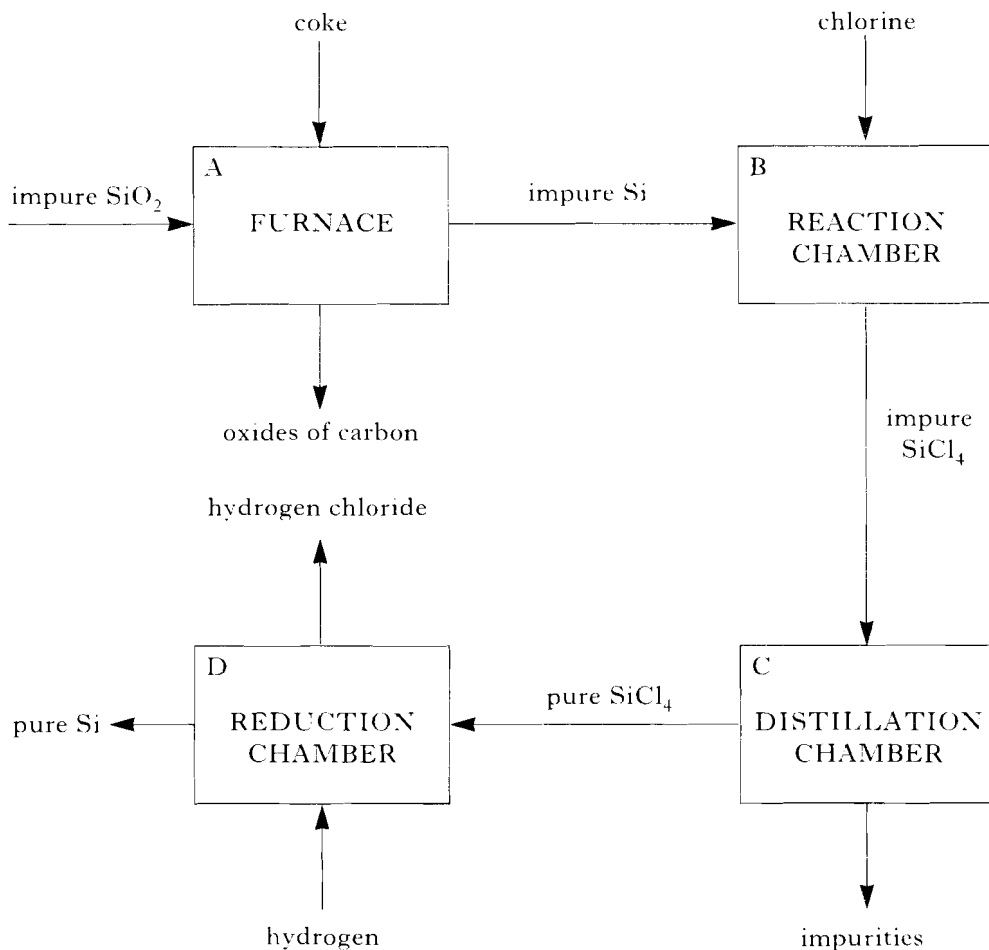

- (a) Which type of reaction is occurring in A? 1
- (b) (i) Write a balanced equation for the formation of SiCl_4 in B. 1
(ii) Use your equation to work out the volume of chlorine (at s.t.p.) required to react exactly with 140 kg of silicon. 2
- (c) SiCl_4 is a liquid (b.p. 58°C).
 SiO_2 is a solid (m.p. 1723°C).
Account for this marked difference. 2
- (d) Why must the distillation apparatus in C be dry? 1
- (e) State a likely industrial source of hydrogen for D. 1
- (f) Give a use for silicon produced in the above process. 1
- (g) Silicon forms a series of hydrides called silanes, which are similar to the alkanes.
(i) Draw the structure of the 3rd member of the silanes. 1
(ii) Name the products of combustion of silanes. 2
- (12)**

- B. In the Downs Process, sodium is extracted from sodium chloride (melting point 800°C) by electrolysis.

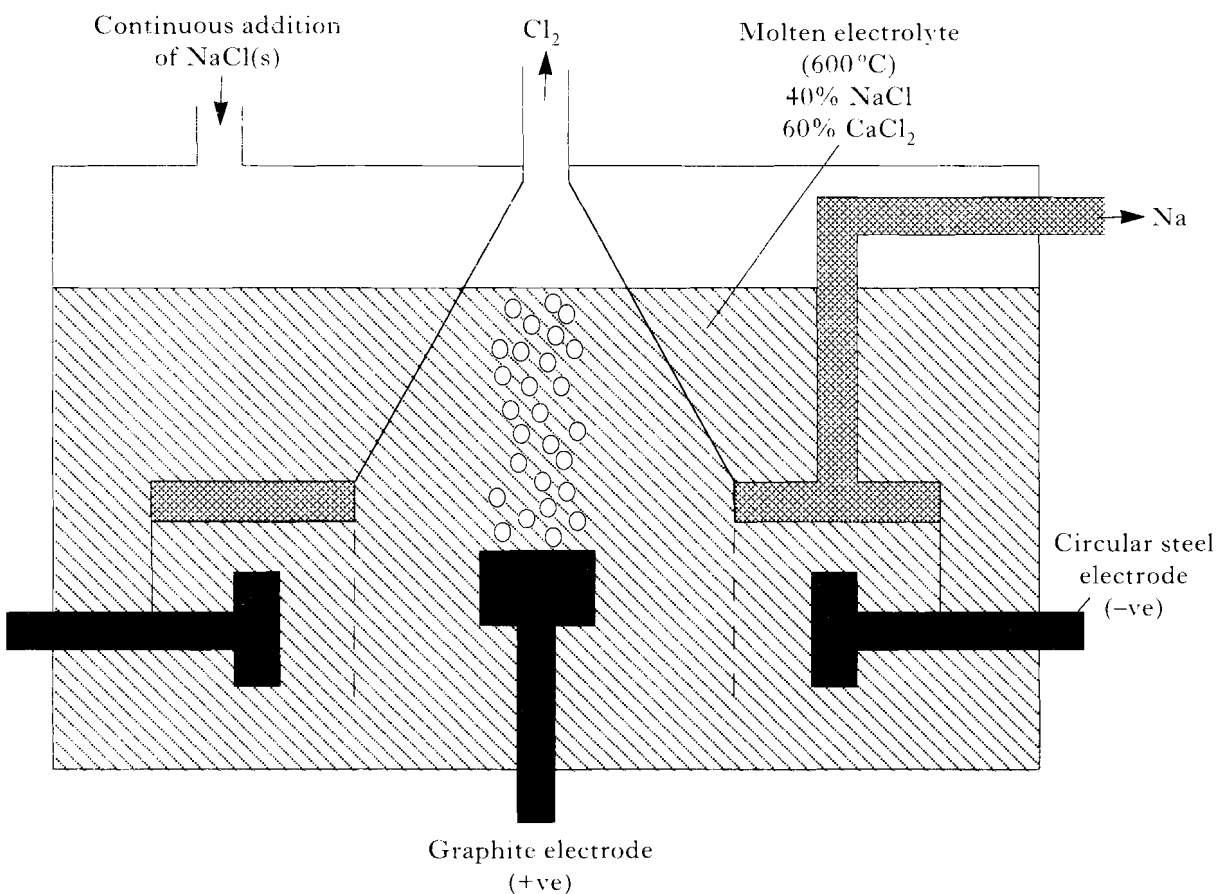

- (a) Suggest why calcium chloride is added to the electrolyte. 1
- (b) Why is calcium not formed to any great extent during the electrolysis? 1
- (c) (i) In which state of matter is the sodium collected? 2
(ii) Explain how you arrived at your answer. 2
- (d) Write ion-electron equations for the reactions occurring during electrolysis at 2
(i) the positive electrode;
(ii) the negative electrode. 2
- (e) Assuming that all the charge flowing produces sodium, calculate the mass of sodium formed when a current of $30\,000\text{A}$ flows for 10 minutes. 3
- (f) Using graphite electrodes, what are the products of electrolysis of a concentrated aqueous solution of sodium chloride? 1
- (g) Give a use for the chlorine produced in the Downs Process. 1
- (h) Despite being the sixth most common element in the earth's crust, sodium was not isolated until the 19th century. Suggest a reason for this fact. 1

(12)

END OF QUESTION PAPER

[0500/313]

1991

SCOTTISH CERTIFICATE OF EDUCATION

CHEMISTRY (REVISED)

Higher Grade – PAPER II

Friday, 17th May—1.30 p.m. to 4.00 p.m.

Fill in these boxes and read what is printed below.*Full Name of school or college**Town**Christian Name: First Name, Initial(s) (of other/middle name(s))**Surname**Date of Birth**Day Month Year*

<input type="text"/>	<input type="text"/>	<input type="text"/>
----------------------	----------------------	----------------------

*Number of seat occupied
at examination*

- All questions should be attempted.
- Necessary data will be found in the Chemistry (Revised) Higher Grade and Certificate of Sixth Year Studies Data Booklet (1990 Edition) which is provided.
- The questions may be answered in any order but all answers are to be written in this answer book, and must be written clearly and legibly in ink.
- Rough work, if any should be necessary, as well as the fair copy, is to be written in this book.
Rough work should be scored through when the fair copy has been written.
- Additional space for answers and rough work will be found at the end of the book. If further space is required, supplementary sheets may be obtained from the Invigilator and should be inserted inside the *front* cover of this booklet.
- The size of the space provided for an answer should not be taken as an indication of how much to write. It is not necessary to use all the space.

1. The first twenty elements of the Periodic Table can be categorised according to their bonding and structure:

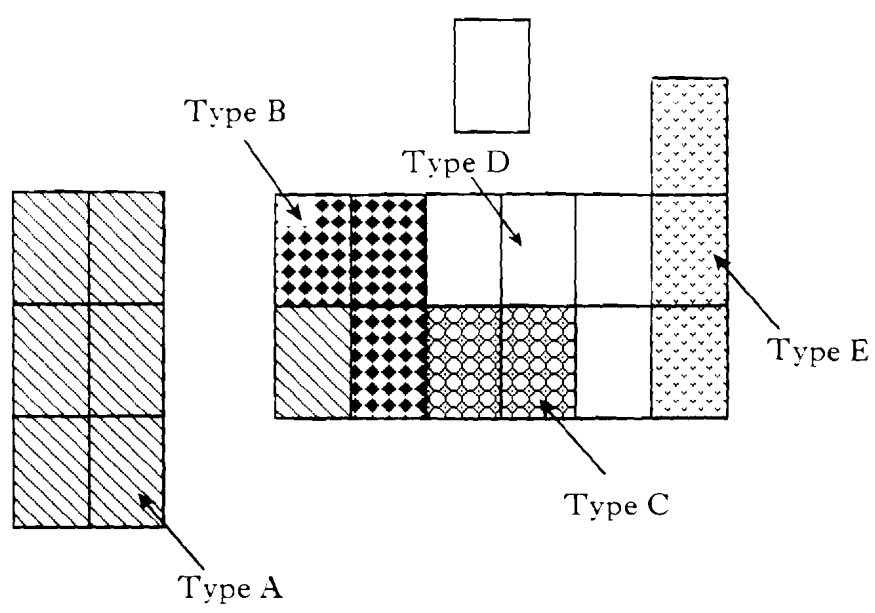

(a) Complete the following table by adding the appropriate letter for each type of element:

Type	Bonding and structure at normal room temperature and pressure
	Monatomic gases
	Covalent network solids
	Diatomic covalent gases
	Discrete covalent molecular solids
	Metallic lattice solids

2

(b) Which of the types contains the element with the greatest attraction for the electrons in a covalent bond?

1
(3)

2. The following diagram shows a laboratory preparation of iron(II) chloride. The gas collected in the gas jar burns explosively in air.

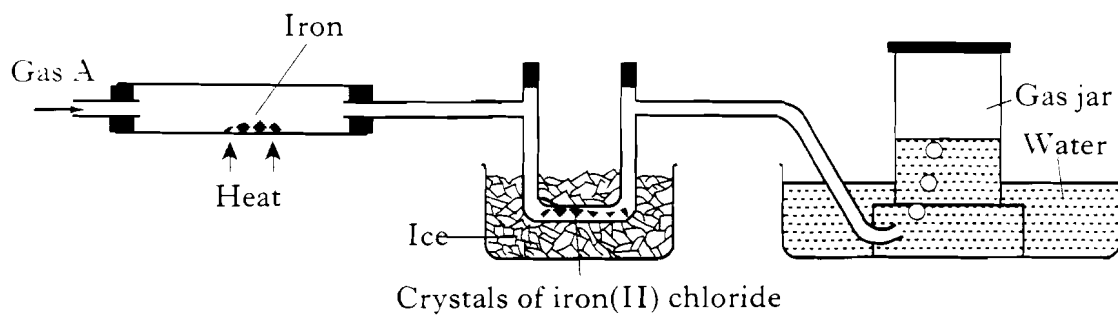

- (a) Name gas A.

1

- (b) What does this method of preparation suggest about the kind of bonding in iron(II) chloride?

1

(2)

[Turn over

3. Part of a chemistry project involved the study of the reaction between methyl ethanoate and sodium hydroxide solution:

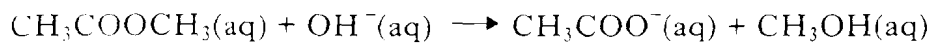

The graph shows the results for one of the experiments:

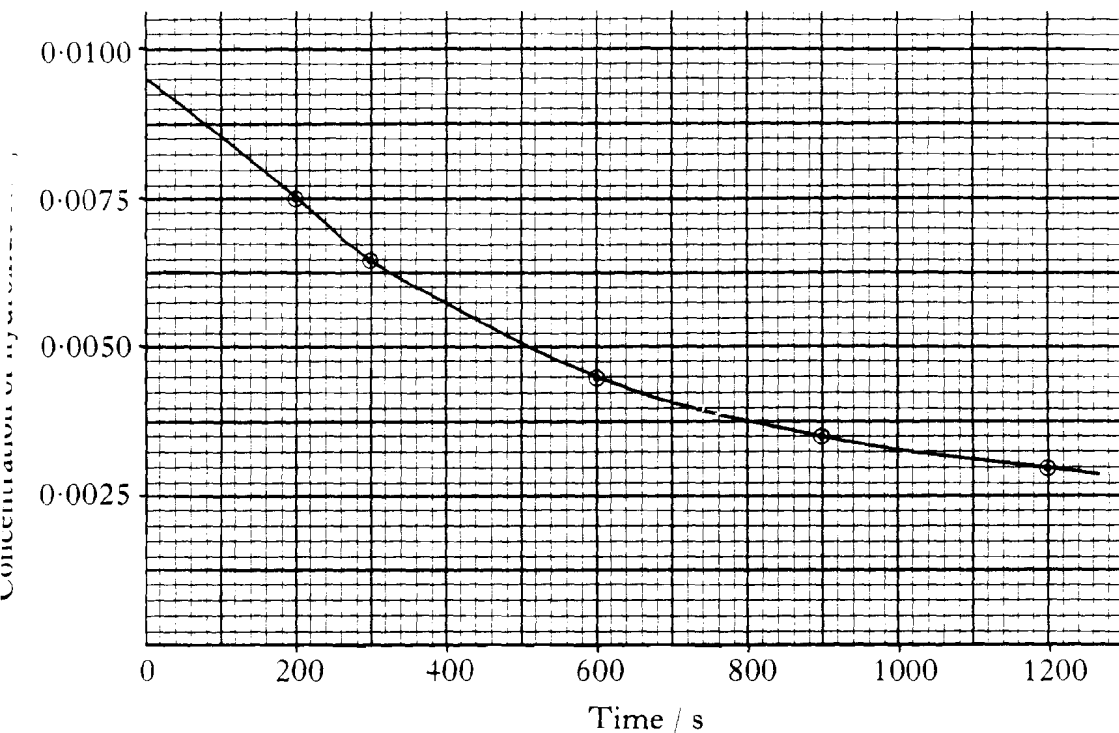

1) What was the initial concentration of the sodium hydroxide solution?

1

2) Suggest how the concentrations of the sodium hydroxide could have been determined.

1

3. (continued)

(c) (i) Calculate the average rate of reaction between 200 and 400 s.

2

(ii) Explain why this was different from the average rate of reaction during the first 200 s of the reaction.

1

(d) The experiment was repeated using a higher temperature.
Explain why the rate of reaction increased.

1

(6)

[Turn over

4. A local company called Electroglaze suggested a project for some 5th year pupils.

PROJECT: NICKEL PLATING OF COPPER USING
NICKEL CHLORIDE SOLUTION

To find the number of coulombs required to plate 1g of nickel on to a piece of copper.

- (a) Draw a diagram of the nickel plating apparatus that could be used in the project.

Clearly label the diagram.

2

- (b) Which measurements would have to be made in the experiment?

2

(4)

5. The following passage is an extract from a scientific journal.

The preparation of bromoethane using ^{60}Co

^{60}Co is a source of γ -rays. It is used in the industrial preparation of bromoethane.

A little liquid bromoethane is placed in a three-necked flask. The ^{60}Co source is suspended in the middle of the flask above the liquid surface. Ethene gas and hydrogen bromide gas are bubbled into the liquid. The unreacted gases are bubbled through a solution to remove the hydrogen bromide gas.

Complete the diagram below to show the apparatus that could have been used in the experiment.

Clearly label the diagram.

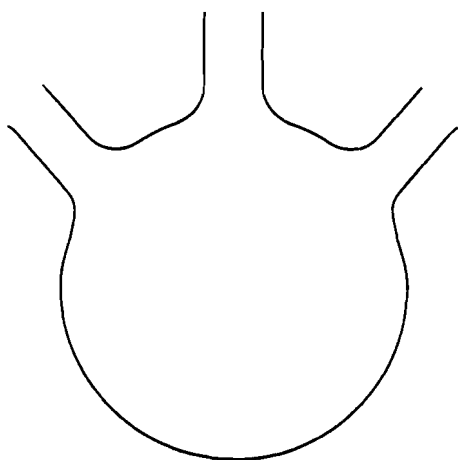

Three-necked flask

(3)

[Turn over

6. Presented below is a simplified flow chart showing some of the processes used in the production of petroleum-based consumer goods.

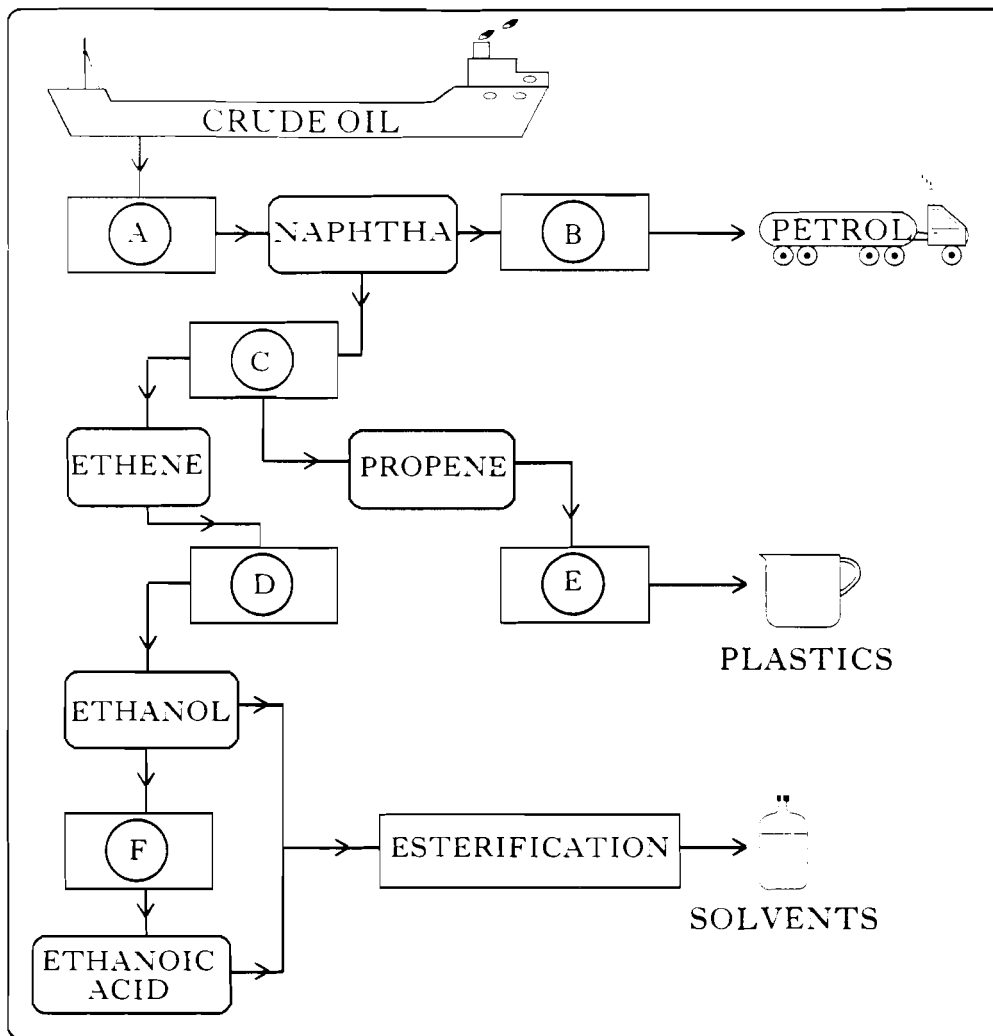

Processes (A) to (F) are contained in the following list:

addition polymerisation; catalytic hydration; cracking; fermentation; fractional distillation; hydrolysis; oxidation; reforming

(a) Identify each process.

- (A) _____
- (B) _____
- (C) _____
- (D) _____
- (E) _____
- (F) _____

6. (continued)

(b) Draw the **full** structural formula for the product of the esterification step in the flow chart.

1

(c) In the laboratory preparation of an ester, sodium hydrogencarbonate is added at the end of the reaction.

(i) Why is this done?

1

(ii) What evidence, apart from smell, shows that a new substance is formed?

1

(6)

[Turn over

7. The bar graph shows the first ionisation enthalpy for some of the elements in group 1 of the Periodic Table.

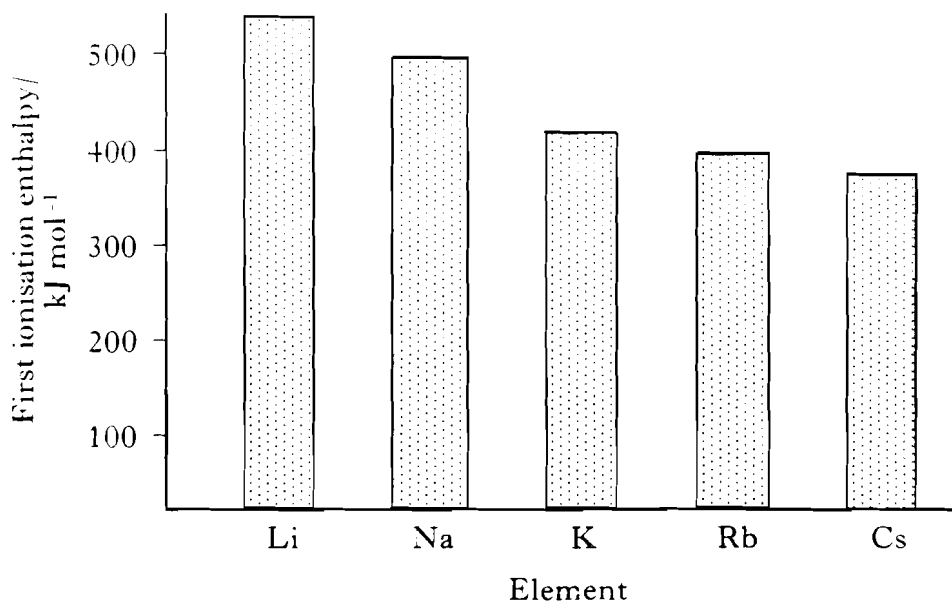

- (a) What is meant by first ionisation enthalpy?

1

- (b) Explain the trend in these ionisation enthalpies:

2

- (c) The ions of the above metals are well hydrated in aqueous solution.

What is meant by hydrated?

1

(4)

8. The booster stage for the Saturn V rocket burned methylhydrazine.

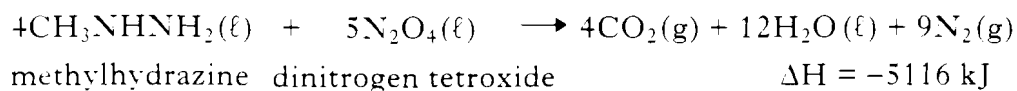

(a) What was the purpose of the dinitrogen tetroxide?

1

(b) Draw the **full** structural formula for methylhydrazine.

1

(c) Calculate the energy which is released when 2 mol of each reactant are mixed and ignited.

1
(3)

9. A chemist was investigating the mass of metal carbonate present in different egg-shells.

The first three steps in the experiments were as follows:

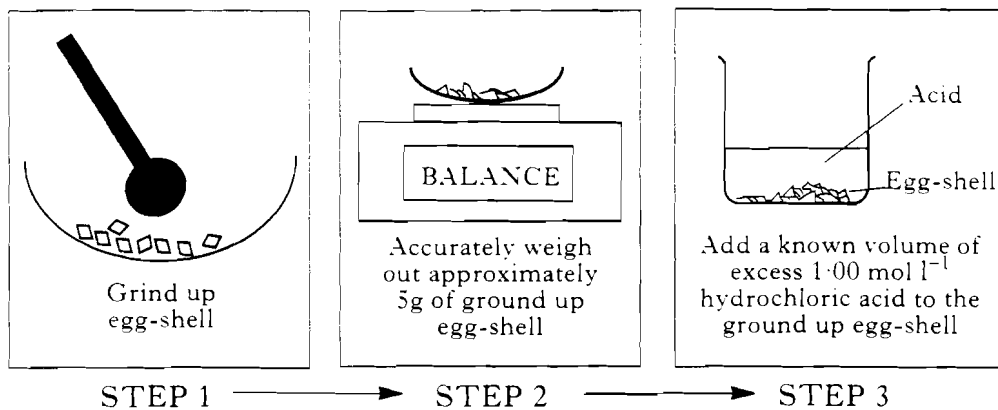

- (a) Explain the use of the terms **accurately** and **approximately** in the description of Step 2.

1

- (b) Suggest why the egg-shells were ground up in Step 1.

1

9. (continued)

- (c) Suggest how the chemist could have determined the volume of acid **reacting** in Step 3.

2

- (d) It was found that one of the egg-shell samples reacted with 50.10 cm^3 of the 1.00 mol l^{-1} hydrochloric acid.

Assuming that the only carbonate present was calcium carbonate, calculate the mass of calcium carbonate present in the egg-shell sample.

3
(7)

10. The flow chart below presents some information about feedstocks from coal.

Marks

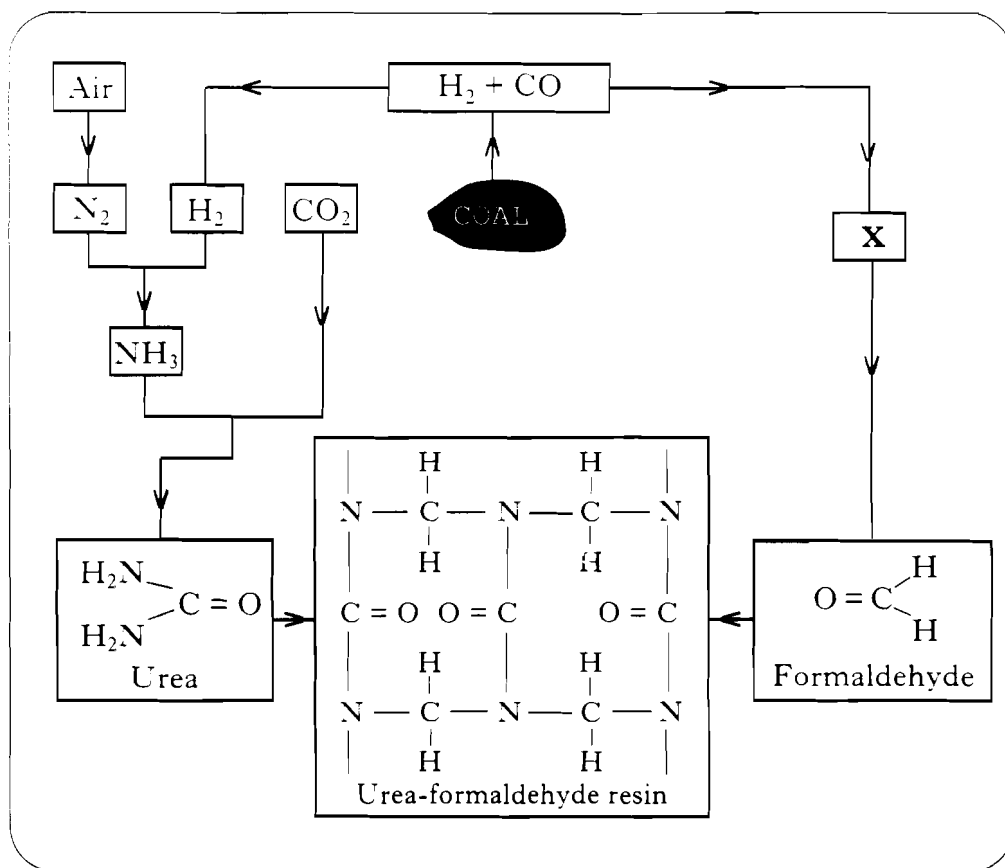

(a) What is the industrial name for the mixture of carbon monoxide and hydrogen produced from coal?

1

(b) Formaldehyde is formed by the oxidation of compound **X**. Name compound **X**.

1

10. (continued)

- (c) During the industrial production of ammonia, the reaction does **not** reach equilibrium.

Give **two** reasons for this.

2

- (d) By referring to the structure of the urea-formaldehyde resin, explain why it is a thermosetting polymer.

1

(5)

11. In 1926, Hinshelwood and Green studied the reaction between nitrogen monoxide and hydrogen at temperatures above 420K.



A simplified diagram of their apparatus is shown below:

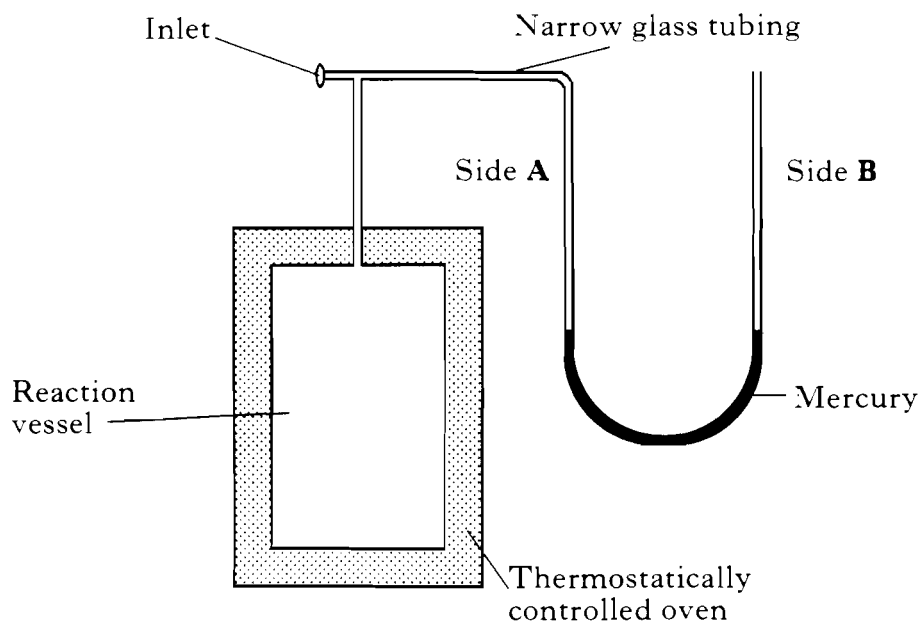

- (a) Explain what happened to the mercury levels as the reaction proceeded.

11. (continued)

- (b) The use of narrow glass tubing ensured that only a small volume of gas was outwith the reaction vessel.

Suggest why this precaution was taken.

1

- (c) Under one set of experimental conditions the molar volume of a gas was 25.0 litres.

Calculate the mass of nitrogen obtained, under these conditions, when 500 cm³ of nitrogen monoxide reacted completely with hydrogen.

2

(5)

[Turn over

12. A group of pupils designed the following apparatus to compare the viscosities of different liquids:

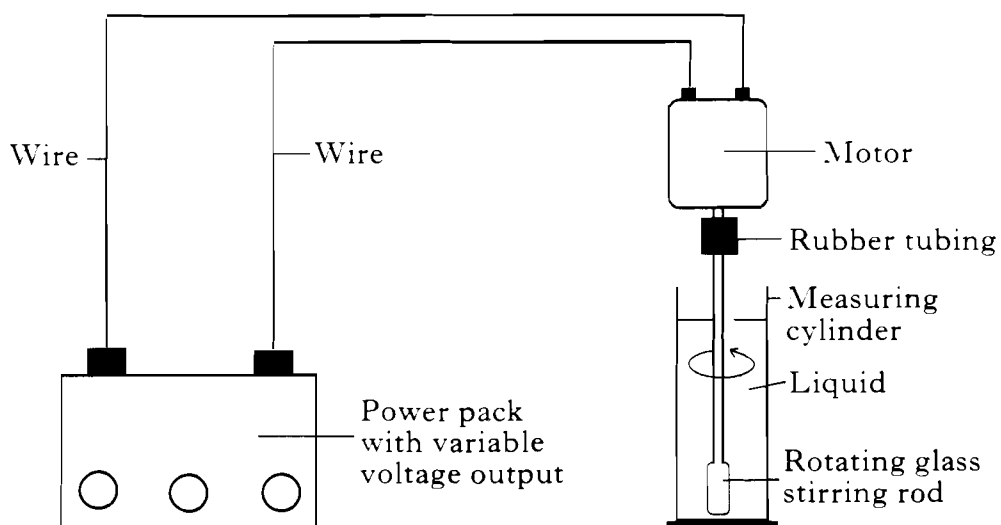

- (a) Suggest how the apparatus could be used to compare the viscosities of different liquids.

2

- (b) The viscosities of many liquids are due to hydrogen bonding. What is meant by hydrogen bonding?

2

(4)

13. The radio-isotope of hydrogen called tritium (${}^3_1\text{H}$) can be used in the dating of stored wines. It has a half-life of 12.3 years.

(a) Write a balanced nuclear equation for the β -decay of tritium.

1

(b) A sample of tritium taken from a wine has a mass of 0.003g.

How many tritium atoms will be present in the sample after 36.9 years?

2

(3)

[Turn over

14. You are asked to investigate the reaction between ethanoic acid (a weak acid) and sodium hydroxide solution.

You are given the following kit list and indicator chart:

KIT LIST	Indicator	Working pH range							
		0	2	4	6	8	10	12	14
Sodium hydroxide solution (0.10 mol l ⁻¹)	Methyl orange			■					
Ethanoic acid solution (0.10 mol l ⁻¹)	Methyl violet	■							
50 cm ³ burette and stand	Bromocresol green			■	■				
20 cm ³ pipette	Methyl red				■				
Indicator solution	Phenolphthalein						■		
Conical flasks									
Pipette filler									

- (a) The indicator chart shows that the working range of methyl red extends to pH 6.

(i) What is the hydrogen ion concentration in a solution of pH 6?

1

(ii) What is the hydroxide ion concentration in such a solution?

1

- (b) Explain why ethanoic acid is classified as a **weak** acid.

1

14. (continued)

- (c) The working pH range of the indicator used in a titration should include the pH value of the salt solution formed in the reaction.
- (i) Name the salt formed in the reaction between ethanoic acid and sodium hydroxide.
- (ii) Which of the indicators given in the chart would you use in the titration of ethanoic acid solution with sodium hydroxide solution?

1

Explain your answer.

2

- (d) Describe carefully how you would determine the volume of ethanoic acid solution needed to neutralise 20 cm^3 of the sodium hydroxide solution.
- You should include the items from the kit list in your description.

3

(9)

15. Sulphur dioxide is sometimes added to fruit juice as a preservative. It dissolves in the juice:

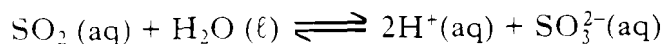

The concentration of sulphur dioxide can be determined using the following apparatus.

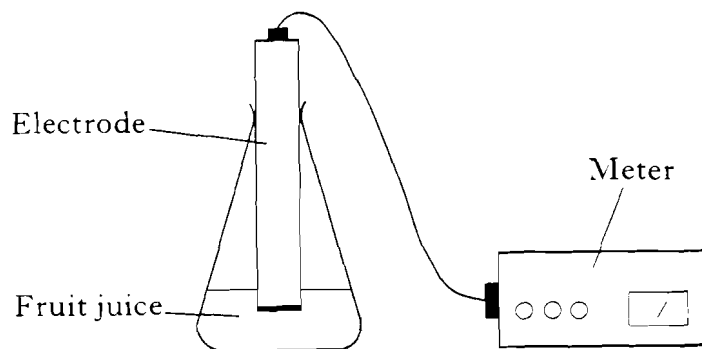

The electrode responds to dissolved sulphur dioxide.

- (a) Explain why sulphuric acid is added to the fruit juice **before** determining the concentration of added sulphur dioxide.

1

- (b) Suggest why the electrode must make a tight fit with the neck of the conical flask.

1

(2)

16. Enzymes are usually far more efficient than catalysts devised by man. Thus, in the decomposition of hydrogen peroxide solution, the enzyme catalase is far more efficient than powdered silver.

(a) Powdered silver behaves as a heterogeneous catalyst in the decomposition of hydrogen peroxide.

What is meant by heterogeneous?

(b) The following potential energy diagram refers to the uncatalysed decomposition:

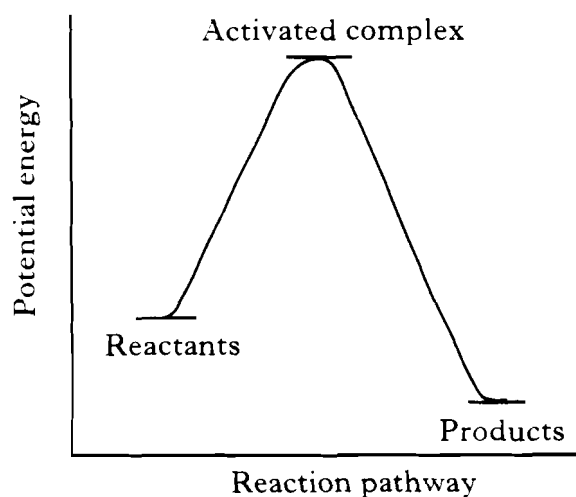

(i) Add a curve to the potential energy diagram to represent the decomposition when catalase is added to hydrogen peroxide solution.

(ii) What is meant by the activated complex?

1

1

1

(3)

17. The first step in the industrial extraction of aluminium is to obtain aluminium oxide from the ore called bauxite.

The ore is crushed. It is then digested, under pressure, with sodium hydroxide solution. The resulting mixture is filtered and the residue (containing large amounts of iron(III) oxide) is removed.

The filtrate is seeded with a little aluminium hydroxide in order to produce **large** amounts of aluminium hydroxide. Sodium hydroxide solution is also formed.

The aluminium hydroxide passes to a rotary kiln where it is roasted to form pure aluminium oxide.

(a) Complete the following flow chart, in order to summarise the production of aluminium oxide.

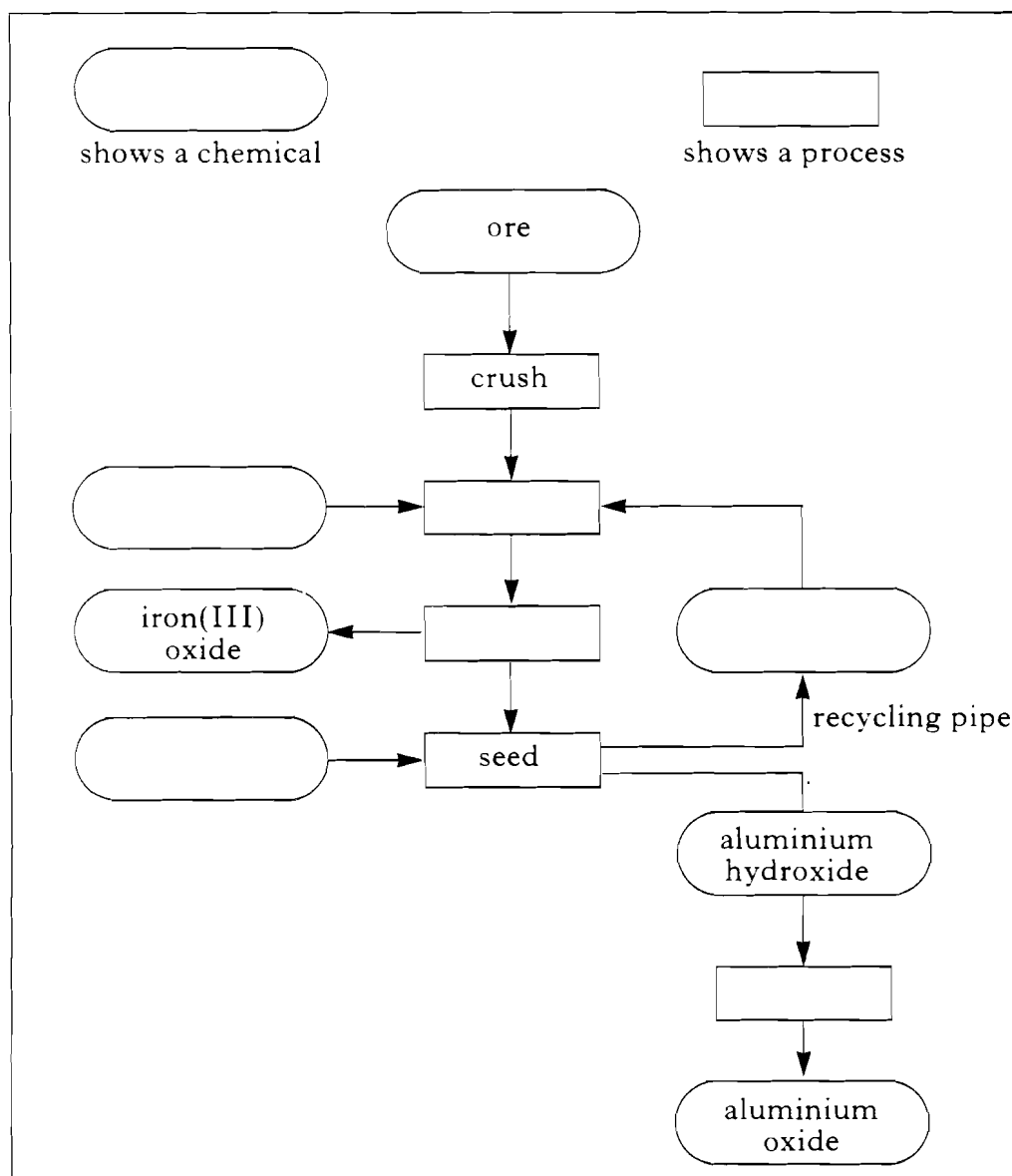

17. (continued)

- (b) Electrolysis of the molten aluminium oxide produces aluminium and oxygen.



- (i) Write the overall ionic equation for the electrolysis of molten aluminium oxide.

1

- (ii) Calculate the mass of aluminium produced when a current of 40 000 A is passed for ten minutes.

2

(5)

18. Chloroethane is used as a local anaesthetic.

It can be prepared by reacting hydrogen chloride with ethene:

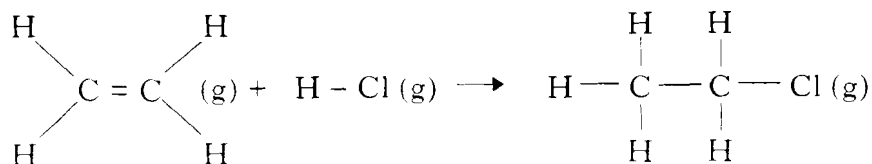

The enthalpy change for the above reaction can be calculated using mean bond enthalpies.

(a) What is meant by the **mean** bond enthalpy?

1

(b) Calculate the enthalpy change for the reaction using the table of Mean Bond Enthalpies on page 11 of the data booklet.

3

(c) Write the equation corresponding to the enthalpy of formation of chloroethane.

1

(5)

19. Straight chain hydrocarbons, branched chain hydrocarbons, cyclic hydrocarbons and aromatic hydrocarbons are all obtained from petroleum oil.

(a) State the systematic name for the following molecule:

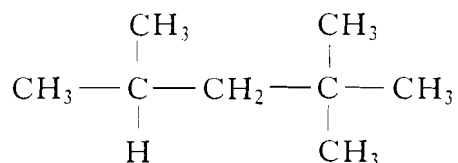

1

(b) Draw the **full** structural formula for 1, 2-dimethylcyclohexane.

1

(c) Name a straight chain hydrocarbon which is an isomer of 1,2-dimethylcyclohexane.

1

(d) Draw the **full** structural formula for an aromatic hydrocarbon with 8 carbon atoms in the molecule.

1
(4)

20. Propanone is a widely used solvent. It can be made from propene.

Using **full** structural formulae show the steps involved in this preparation and **name** the reagents used in each step.

(3)

21. Trichlorophenol (TCP) is an antiseptic which is used to relieve throat infection. It is prepared from phenol as follows:

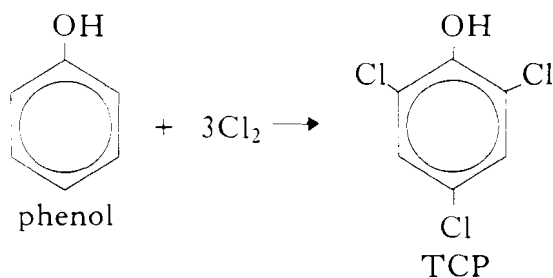

Calculate the percentage yield if 488 g of TCP is obtained from 250 g of phenol.

(2)

[Turn over

22. The bonds in organic molecules absorb infra-red radiation. The same bond in different molecules always absorbs infra-red radiation of similar wavenumber. For example, the C—H bond absorbs in the range 2800 – 3000 wavenumbers (cm^{-1}).

The following diagrams refer to three different organic liquids.

pentane

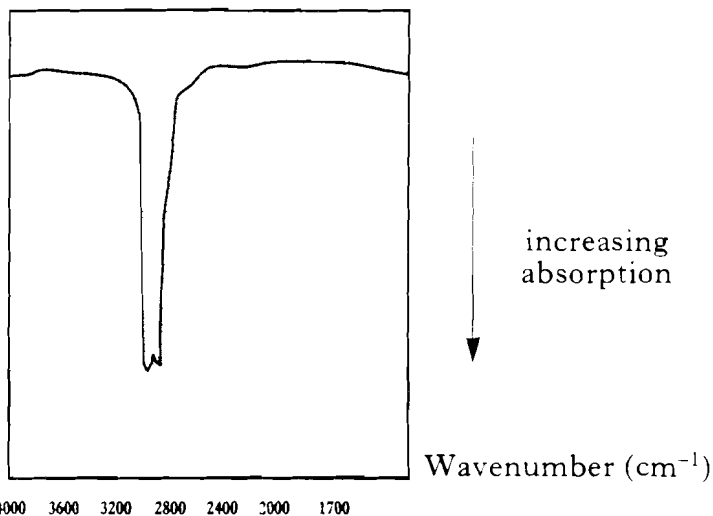
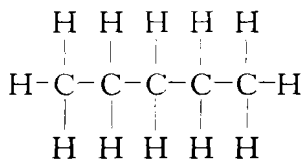

pentan-2-one

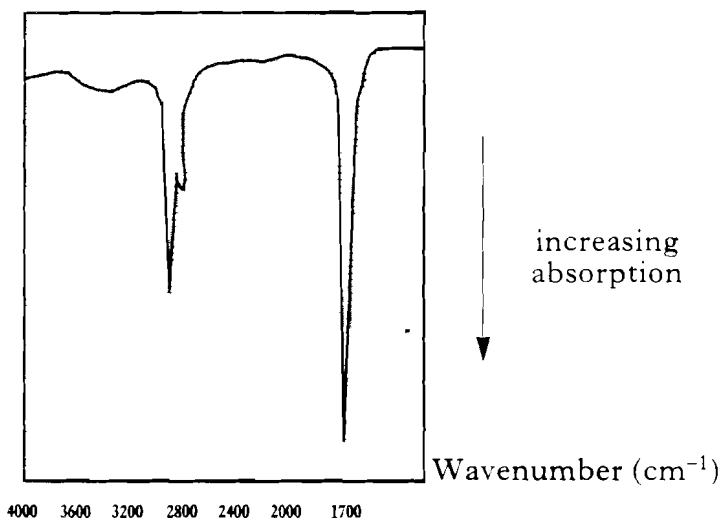
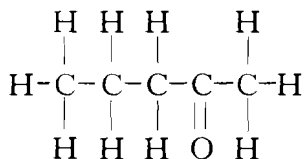

pentan-1-ol

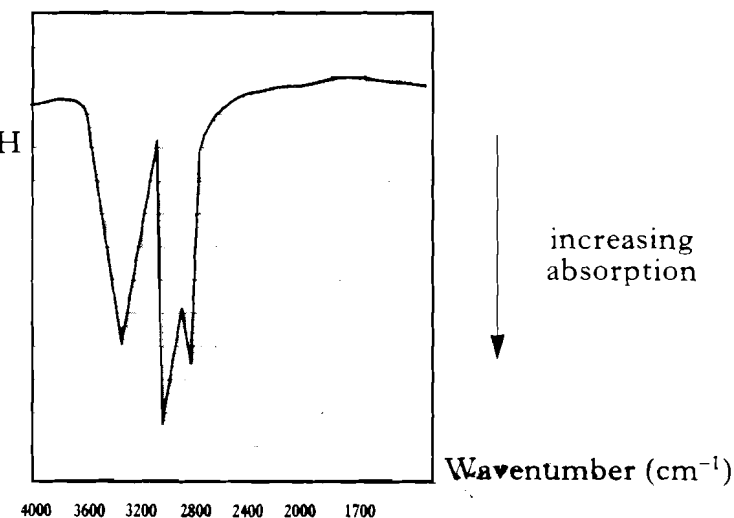
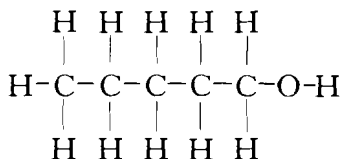

22. (continued)

- (a) The absorption at 1710 cm^{-1} in the spectrum of pentan-2-one is absent from the spectrum of pentane and pentan-1-ol.

Which bond could be responsible for this absorption?

1

- (b) Use the outline below to sketch the absorptions you would predict for pentanoic acid.

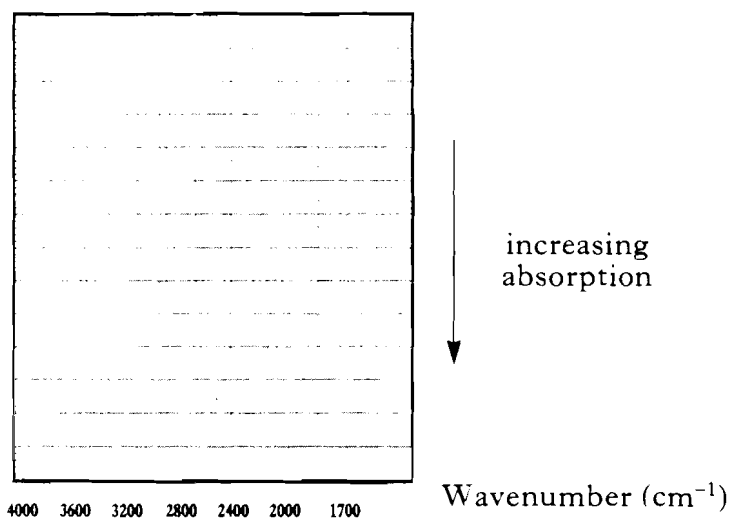
1
(2)

[END OF QUESTION PAPER]