

X069/301

NATIONAL
QUALIFICATIONS
2006

WEDNESDAY, 17 MAY
1.00 PM – 3.30 PM

PHYSICS
HIGHER

Read Carefully

Reference may be made to the **Physics Data Booklet**.

- 1 All questions should be attempted.

Section A (questions 1 to 20)

- 2 Check that the answer sheet is for Physics Higher (Section A).
- 3 For this section of the examination you must use an **HB pencil** and, where necessary, an eraser.
- 4 Check that the answer sheet you have been given has **your name, date of birth, SCN** (Scottish Candidate Number) and **Centre Name** printed on it.
Do not change any of these details.
- 5 If any of this information is wrong, tell the Invigilator immediately.
- 6 If this information is correct, **print** your name and seat number in the boxes provided.
- 7 There is **only one correct** answer to each question.
- 8 Any rough working should be done on the question paper or the rough working sheet, **not** on your answer sheet.
- 9 At the end of the exam, put the **answer sheet for Section A inside the front cover of your answer book**.
- 10 Instructions as to how to record your answers to questions 1–20 are given on page three.

Section B (questions 21 to 29)

- 11 Answer the questions numbered 21 to 29 in the answer book provided.
- 12 **All answers must be written clearly and legibly in ink.**
- 13 Fill in the details on the front of the answer book.
- 14 Enter the question number clearly in the margin of the answer book beside each of your answers to questions 21 to 29.
- 15 Care should be taken to give an appropriate number of significant figures in the final answers to calculations.



DATA SHEET
COMMON PHYSICAL QUANTITIES

<i>Quantity</i>	<i>Symbol</i>	<i>Value</i>	<i>Quantity</i>	<i>Symbol</i>	<i>Value</i>
Speed of light in vacuum	c	$3.00 \times 10^8 \text{ m s}^{-1}$	Mass of electron	m_e	$9.11 \times 10^{-31} \text{ kg}$
Magnitude of the charge on an electron	e	$1.60 \times 10^{-19} \text{ C}$	Mass of neutron	m_n	$1.675 \times 10^{-27} \text{ kg}$
Gravitational acceleration on Earth	g	9.8 m s^{-2}	Mass of proton	m_p	$1.673 \times 10^{-27} \text{ kg}$
Planck's constant	h	$6.63 \times 10^{-34} \text{ J s}$			

REFRACTIVE INDICES

The refractive indices refer to sodium light of wavelength 589 nm and to substances at a temperature of 273 K.

<i>Substance</i>	<i>Refractive index</i>	<i>Substance</i>	<i>Refractive index</i>
Diamond	2.42	Water	1.33
Crown glass	1.50	Air	1.00

SPECTRAL LINES

<i>Element</i>	<i>Wavelength/nm</i>	<i>Colour</i>	<i>Element</i>	<i>Wavelength/nm</i>	<i>Colour</i>
Hydrogen	656	Red	Cadmium	644	Red
	486	Blue-green		509	Green
	434	Blue-violet		480	Blue
	410	Violet	<i>Lasers</i>		
	397	Ultraviolet	<i>Element</i>	<i>Wavelength/nm</i>	<i>Colour</i>
	389	Ultraviolet	Carbon dioxide	9550 } 10590 }	Infrared
Sodium	589	Yellow	Helium-neon	633	Red

PROPERTIES OF SELECTED MATERIALS

<i>Substance</i>	<i>Density/ kg m⁻³</i>	<i>Melting Point/ K</i>	<i>Boiling Point/ K</i>
Aluminium	2.70×10^3	933	2623
Copper	8.96×10^3	1357	2853
Ice	9.20×10^2	273	...
Sea Water	1.02×10^3	264	377
Water	1.00×10^3	273	373
Air	1.29
Hydrogen	9.0×10^{-2}	14	20

The gas densities refer to a temperature of 273 K and a pressure of $1.01 \times 10^5 \text{ Pa}$.

SECTION A

For questions 1 to 20 in this section of the paper the answer to each question is either A, B, C, D or E. Decide what your answer is, then, using your pencil, put a horizontal line in the space provided—see the example below.

EXAMPLE

The energy unit measured by the electricity meter in your home is the

- A kilowatt-hour
- B ampere
- C watt
- D coulomb
- E volt.

The correct answer is **A**—kilowatt-hour. The answer **A** has been clearly marked in **pencil** with a horizontal line (see below).

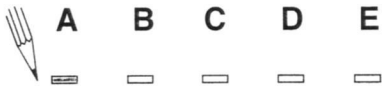

Changing an answer

If you decide to change your answer, carefully erase your first answer and, using your pencil, fill in the answer you want. The answer below has been changed to **E**.



[Turn over

SECTION A

Answer questions 1–20 on the answer sheet.

1. Which of the following contains one scalar quantity and one vector quantity?

- A acceleration; displacement
- B kinetic energy; speed
- C momentum; velocity
- D potential energy; work
- E power; weight

2. A golfer strikes a golf ball which then moves off at an angle to the ground. The ball follows the path shown.

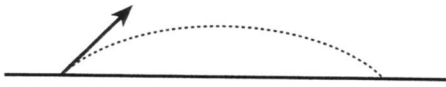

The graphs below show how the horizontal and vertical components of the velocity of the ball vary with time.

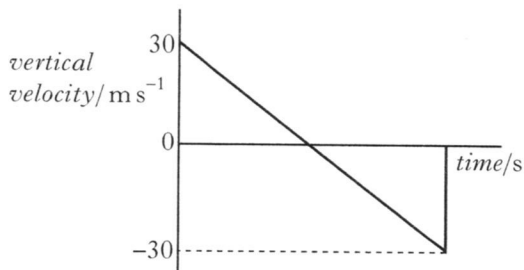
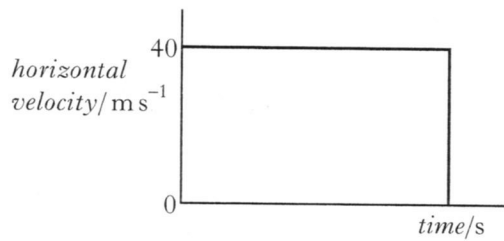

What is the speed of the ball just before it hits the ground?

- A 10 m s^{-1}
- B 30 m s^{-1}
- C 40 m s^{-1}
- D 50 m s^{-1}
- E 70 m s^{-1}

3. An object starts from rest and accelerates in a straight line.

The graph shows how the acceleration of the object varies with time.

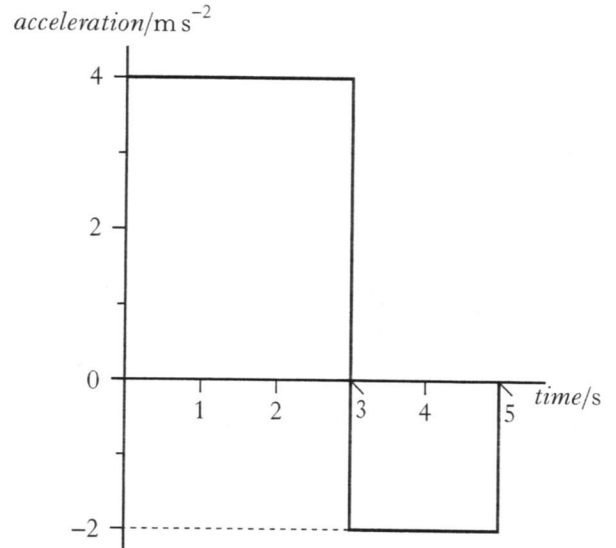

The object's speed at 5 seconds is

- A 2 m s^{-1}
- B 8 m s^{-1}
- C 12 m s^{-1}
- D 16 m s^{-1}
- E 20 m s^{-1}

4. A person stands on bathroom scales in a lift. The scales show a reading greater than the person's weight.

The lift is moving

- A upwards at constant velocity
- B downwards at constant velocity
- C downwards and accelerating
- D downwards and decelerating
- E upwards and decelerating.

5. Two trolleys travel towards each other in a straight line as shown.

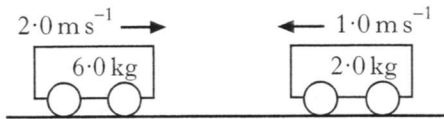

The trolleys collide. After the collision the trolleys move as shown below.

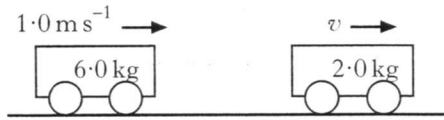

What is the speed v of the 2.0 kg trolley after the collision?

- A 1.25 m s^{-1}
 B 1.75 m s^{-1}
 C 2.0 m s^{-1}
 D 4.0 m s^{-1}
 E 5.0 m s^{-1}
6. A student carries out an experiment to determine the density of a liquid. The results are shown.

volume of liquid in beaker = $2.00 \times 10^{-5} \text{ m}^3$
 mass of empty beaker = $3.00 \times 10^{-2} \text{ kg}$
 mass of filled beaker = $4.50 \times 10^{-2} \text{ kg}$

The density of the liquid is

- A $4.44 \times 10^{-4} \text{ kg m}^{-3}$
 B $1.33 \times 10^{-3} \text{ kg m}^{-3}$
 C $7.50 \times 10^2 \text{ kg m}^{-3}$
 D $2.25 \times 10^3 \text{ kg m}^{-3}$
 E $3.75 \times 10^3 \text{ kg m}^{-3}$.

7. Which pair of graphs shows how the pressure produced by a liquid depends on the depth and density of the liquid?

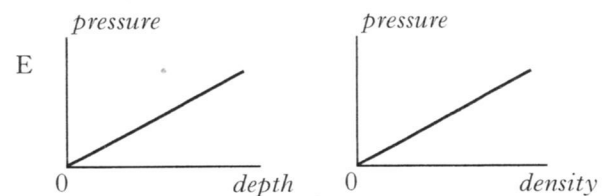
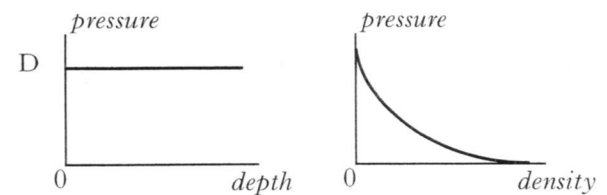
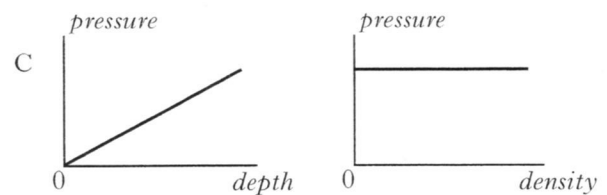
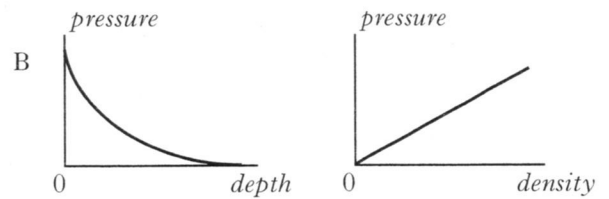
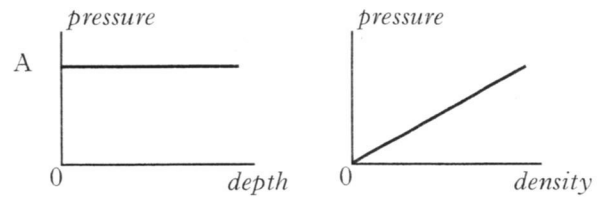

[Turn over

8. Three resistors are connected as shown.

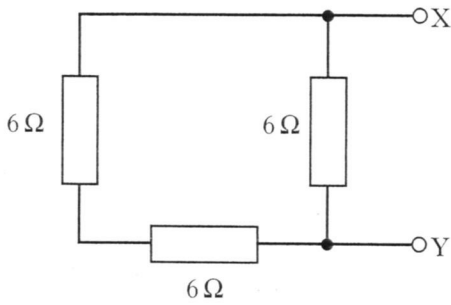

The total resistance between X and Y is

- A 2 Ω
- B 4 Ω
- C 6 Ω
- D 9 Ω
- E 18 Ω

9. A battery of e.m.f. 12 V and internal resistance 3.0 Ω is connected in a circuit as shown.

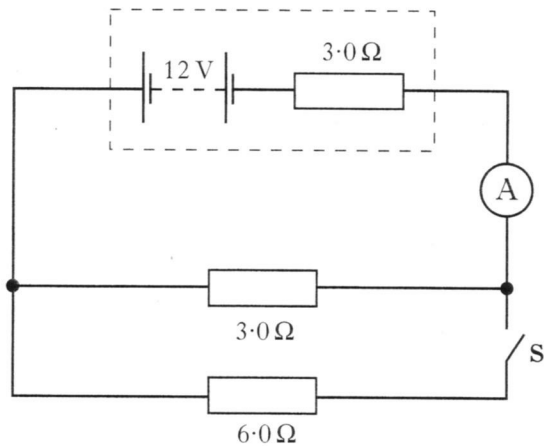

When switch **S** is closed the ammeter reading changes from

- A 2.0 A to 1.0 A
- B 2.0 A to 2.4 A
- C 2.0 A to 10 A
- D 4.0 A to 1.3 A
- E 4.0 A to 6.0 A

10. The circuit diagram shows a balanced Wheatstone bridge.

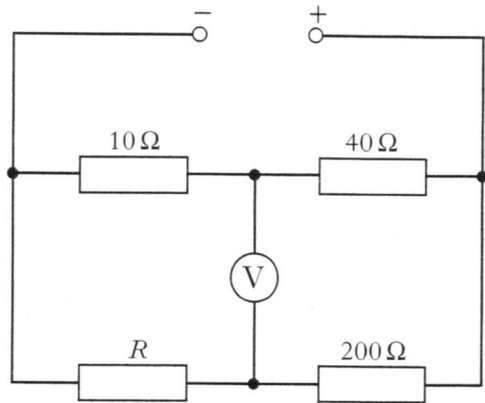

The resistance of resistor *R* is

- A 0.5 Ω
- B 2.0 Ω
- C 50 Ω
- D 100 Ω
- E 800 Ω

11. A student carries out three experiments to investigate the charging of a capacitor using a d.c. supply.

The graphs obtained from the experiments are shown.

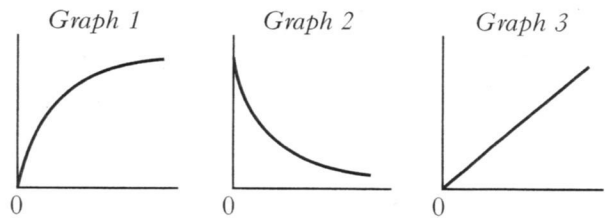

The axes of the graphs have not been labelled.

Which row in the table shows the labels for the axes of the graphs?

	<i>Graph 1</i>	<i>Graph 2</i>	<i>Graph 3</i>
A	voltage and time	current and time	charge and voltage
B	current and time	voltage and time	charge and voltage
C	current and time	charge and voltage	voltage and time
D	charge and voltage	current and time	voltage and time
E	voltage and time	charge and voltage	current and time

12. The following circuit shows a constant voltage a.c. supply connected to a resistor and capacitor in parallel.

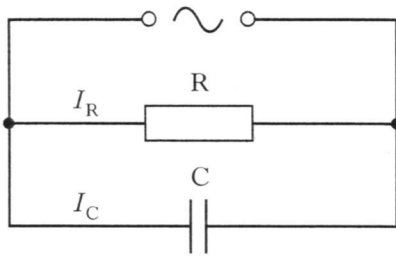

Which pair of graphs shows how the r.m.s. currents I_R and I_C vary as the frequency f of the supply is increased?

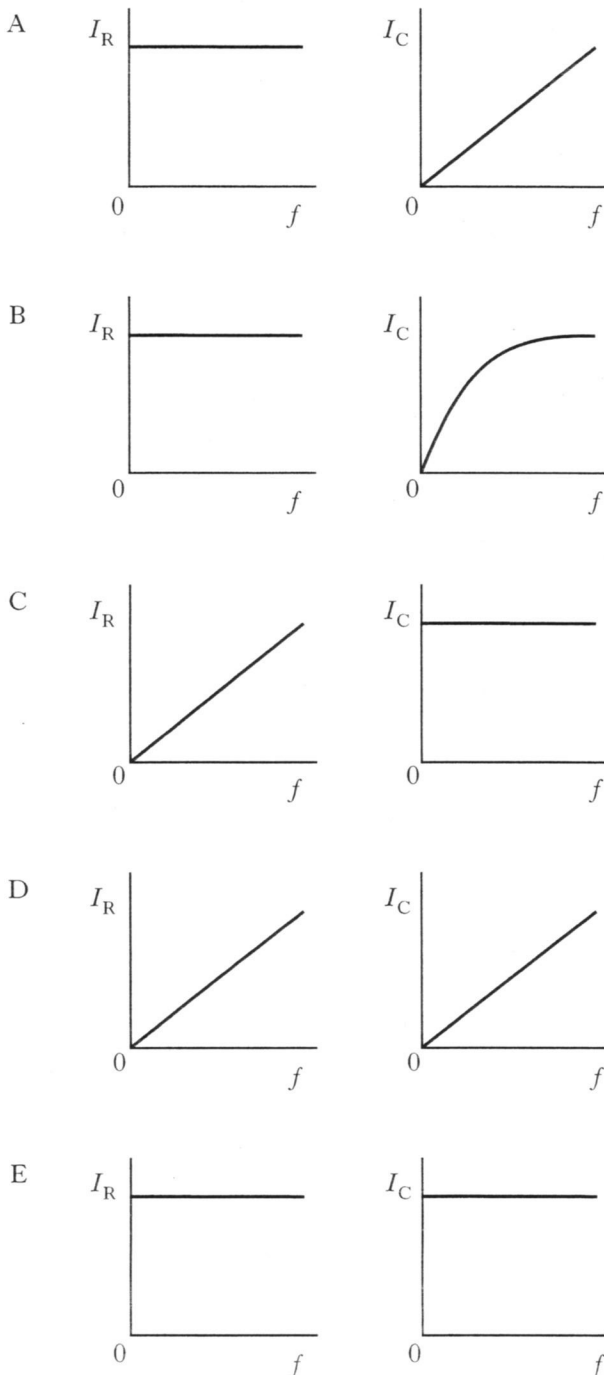

13. An op-amp circuit is set up as shown.

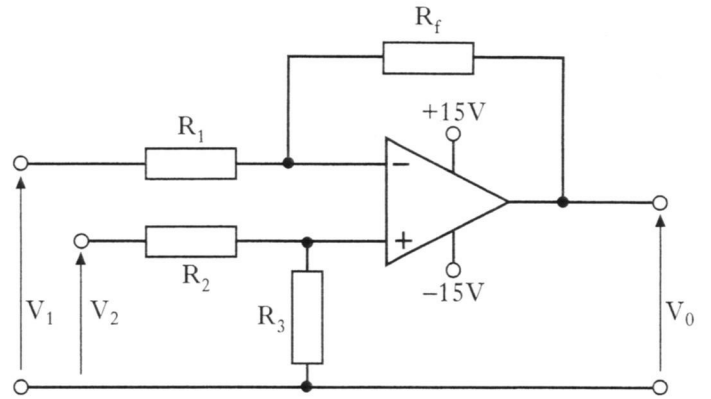

Which of the following statements is/are true?

- I The circuit is connected in the inverting mode.
- II The circuit amplifies the difference between V_2 and V_1 .
- III The maximum possible output voltage $V_0 = V_1 + V_2$.

- A I only
- B II only
- C I and II only
- D II and III only
- E I, II and III

14. A microwave source at point O produces waves of wavelength 28 mm.

A metal reflector is placed as shown.

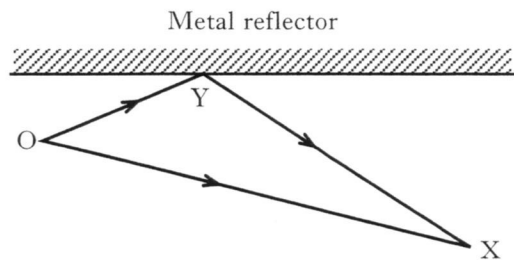

An interference pattern is produced.

Constructive interference occurs at point X.

The distance OX is 400 mm.

The total path length OYX is

- A 414 mm
- B 421 mm
- C 442 mm
- D 456 mm
- E 463 mm.

15. The diagram represents a ray of light passing from air into liquid.

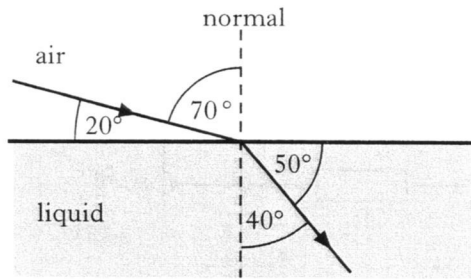

The refractive index of this liquid, relative to air, is

- A $\frac{\sin 20^\circ}{\sin 40^\circ}$
 B $\frac{\sin 40^\circ}{\sin 70^\circ}$
 C $\frac{\sin 50^\circ}{\sin 20^\circ}$
 D $\frac{\sin 70^\circ}{\sin 40^\circ}$
 E $\frac{\sin 90^\circ}{\sin 40^\circ}$.

16. Light travels from air into glass.

Which row in the table describes what happens to the speed, frequency and wavelength of the light?

	<i>Speed</i>	<i>Frequency</i>	<i>Wavelength</i>
A	increases	stays constant	increases
B	increases	decreases	stays constant
C	stays constant	decreases	decreases
D	decreases	decreases	stays constant
E	decreases	stays constant	decreases

17. When light of frequency f is shone on to a certain metal, photoelectrons are ejected with a maximum velocity v and kinetic energy E_k .

Light of the same frequency but twice the irradiance is shone on to the same surface.

Which of the following statements is/are correct?

- I Twice as many electrons are ejected per second.
 II The speed of the fastest electron is $2v$.
 III The kinetic energy of the fastest electron is now $2E_k$.
- A I only
 B II only
 C III only
 D I and II only
 E I, II and III

18. The diagram shows some of the energy levels for the hydrogen atom.

$$E_3 \text{ ————— } -1.360 \times 10^{-19} \text{ J}$$

$$E_2 \text{ ————— } -2.416 \times 10^{-19} \text{ J}$$

$$E_1 \text{ ————— } -5.424 \times 10^{-19} \text{ J}$$

$$E_0 \text{ ————— } -21.76 \times 10^{-19} \text{ J}$$

The highest frequency of radiation emitted due to a transition between two of these energy levels is

- A $1.59 \times 10^{14} \text{ Hz}$
 B $2.46 \times 10^{15} \text{ Hz}$
 C $3.08 \times 10^{15} \text{ Hz}$
 D $1.63 \times 10^{20} \text{ Hz}$
 E $2.04 \times 10^{20} \text{ Hz}$.

19. A series of radioactive decays starts from the isotope Uranium 238.

Two alpha particles and two beta particles are emitted during the decays.

Which row in the table gives the mass number and the atomic number of the resulting nucleus?

	<i>Mass number</i>	<i>Atomic number</i>
A	232	88
B	230	86
C	230	90
D	246	94
E	246	98

20. The table shows the radiation weighting factor w_R for a number of different radiations.

<i>Type of radiation</i>	<i>Radiation weighting factor w_R</i>
alpha particles	20
beta particles	1
neutrons	3
gamma rays	1
X-rays	0.1

Which of the following gives the greatest equivalent dose?

- A 8 μGy of alpha particles
- B 170 μGy of beta particles
- C 56 μGy of neutrons
- D 160 μGy of gamma rays
- E 1500 μGy of X-rays

SECTION B begins on *Page eleven*

SECTION B

Write your answers to questions 21 to 29 in the answer book.

Marks

21. A van of mass 2600 kg moves down a slope which is inclined at 12° to the horizontal as shown.

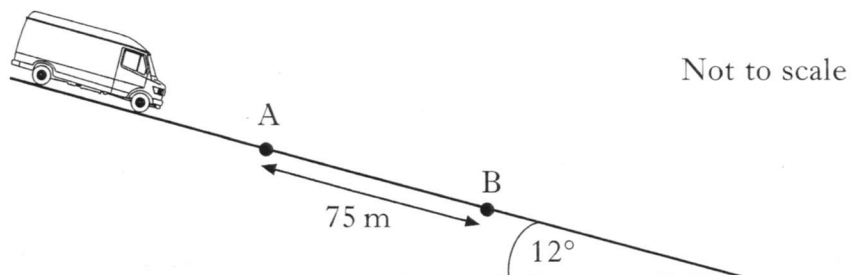

- (a) Calculate the component of the van's weight parallel to the slope. 2
- (b) A constant frictional force of 1400 N acts on the van as it moves down the slope.
Calculate the acceleration of the van. 2
- (c) The speed of the van as it passes point **A** is 5.0 m s^{-1} .
Point **B** is 75 m further down the slope.
Calculate the kinetic energy of the van at **B**. 3
- (7)

[Turn over

22. A force sensor is used to investigate the impact of a ball as it bounces on a flat horizontal surface. The ball has a mass of 0.050 kg and is dropped vertically, from rest, through a height of 1.6 m as shown.

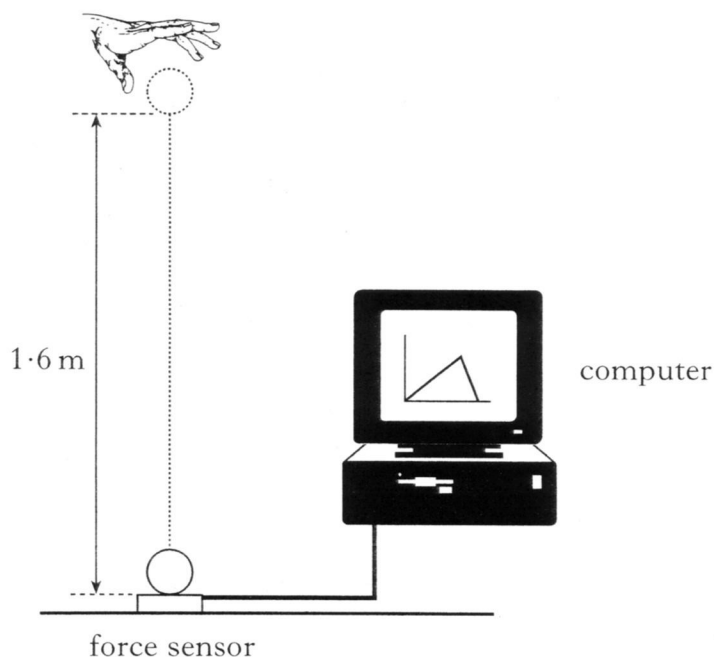

- (a) The graph shows how the force on the ball varies with time during the impact.

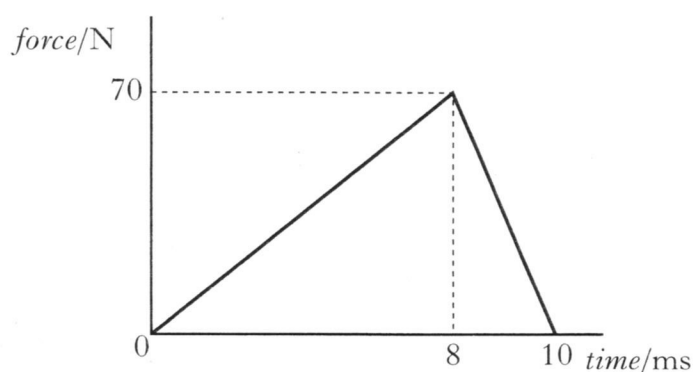

- (i) Show by calculation that the magnitude of the impulse on the ball is 0.35 N s . 1
- (ii) What is the magnitude and direction of the change in momentum of the ball? 1
- (iii) The ball is travelling at 5.6 m s^{-1} just before it hits the force sensor. Calculate the speed of the ball just as it leaves the force sensor. 2
- (b) Another ball of identical size and mass, but made of a harder material, is dropped from rest and from the same height onto the same force sensor. Sketch the force-time graph shown above and, on the same axes, sketch another graph to show how the force on the harder ball varies with time. Numerical values are not required but you must label the graphs clearly. 2
- (6)**

23. A refrigerated cool box is being prepared to carry medical supplies in a hot country. The **internal** dimensions of the box are $0.30\text{ m} \times 0.20\text{ m} \times 0.50\text{ m}$.

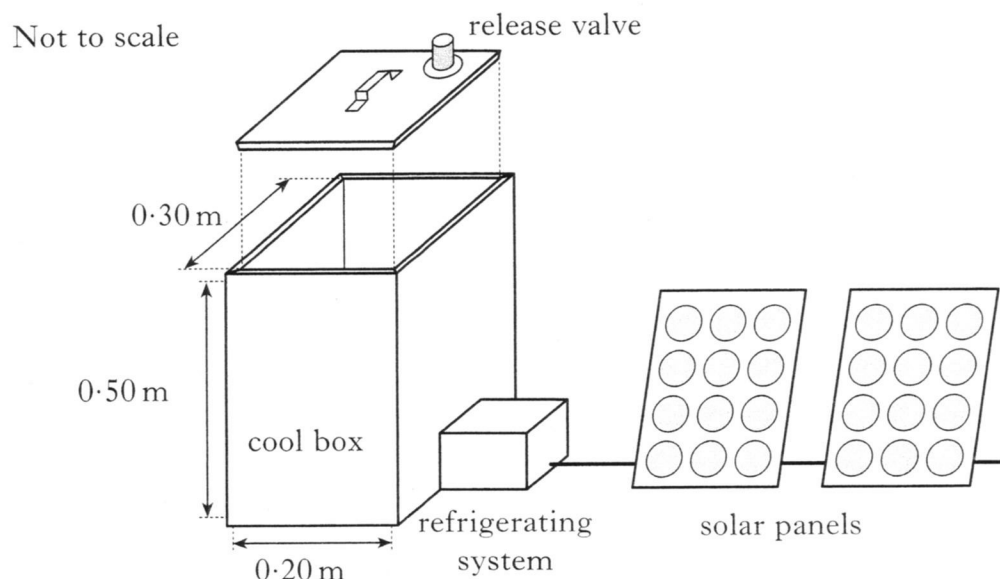

The lid is placed on the cool box with the release valve closed. An airtight seal is formed. When the lid is closed the air inside the cool box is at a temperature of $33\text{ }^\circ\text{C}$ and a pressure of $1.01 \times 10^5\text{ Pa}$.

The refrigerating system then reduces the temperature of the air inside the cool box until it reaches its working temperature.

At this temperature the air inside is at a pressure of $9.05 \times 10^4\text{ Pa}$.

- (a) (i) Calculate the temperature of the air inside the cool box when it is at its working temperature. 2
- (ii) Describe, using the kinetic model, how the decrease in temperature affects the air pressure inside the cool box. 2
- (b) (i) Atmospheric pressure is $1.01 \times 10^5\text{ Pa}$.
Show that the magnitude of the force on the lid due to the difference in air pressure between the inside and outside of the cool box is now 630 N . 2
- (ii) The mass of the lid is 1.50 kg .
Calculate the minimum force required to lift off the lid when the cool box is at its working temperature. 1
- (iii) The release valve allows air to pass into or out of the cool box.
Explain why this valve should be opened before lifting the lid. 1
- (c) The refrigerating system requires an average current of 0.80 A at 12 V .
Each solar panel has a power output of 3.4 W at 12 V .
Calculate the minimum number of solar panels needed to operate the refrigerating system. 2

(10)

24. The diagram below shows the basic features of a proton accelerator. It is enclosed in an evacuated container.

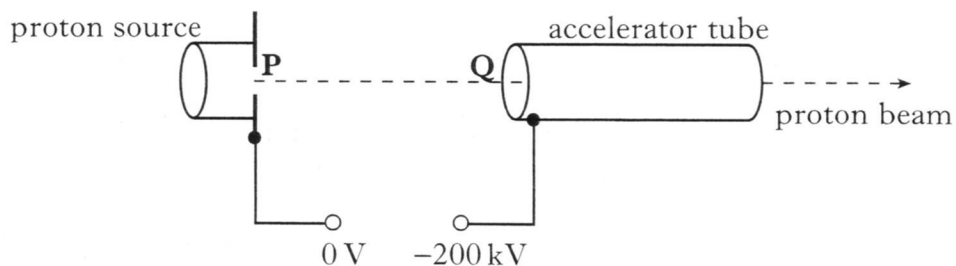

Protons released from the proton source start from rest at **P**.
A potential difference of 200 kV is maintained between **P** and **Q**.

- (a) What is meant by the term *potential difference of 200 kV*? 1
- (b) Explain why protons released at **P** are accelerated towards **Q**. 1
- (c) Calculate:
- (i) the work done on a proton as it accelerates from **P** to **Q**; 2
- (ii) the speed of a proton as it reaches **Q**. 2
- (d) The distance between **P** and **Q** is now halved.
- What effect, if any, does this change have on the speed of a proton as it reaches **Q**? Justify your answer. 2
- (8)**

25. The 9.0 V battery in the circuit shown below has negligible internal resistance.

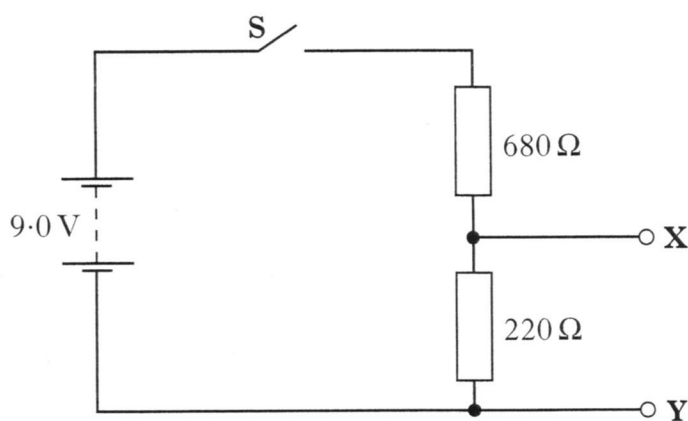

(a) Switch **S** is closed.
Calculate the potential difference between **X** and **Y**. 2

(b) Switch **S** is opened.
An uncharged $33\ \mu\text{F}$ capacitor is connected between **X** and **Y** as shown.

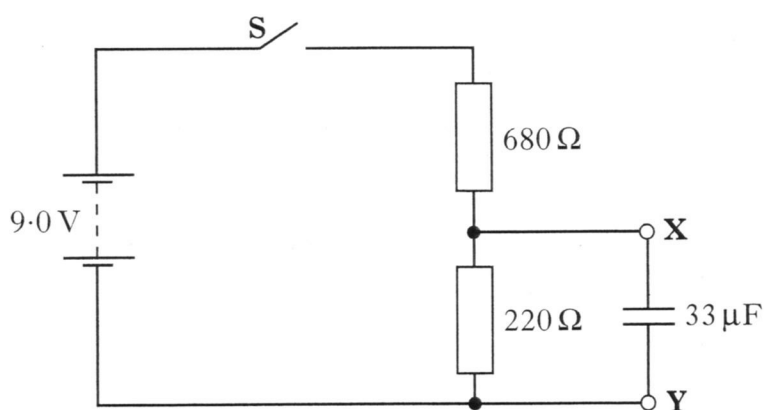

Switch **S** is then closed.

- (i) Explain why work is done in charging the capacitor. 1
- (ii) State the value of the maximum potential difference across the capacitor in this circuit. 1
- (iii) Calculate the maximum energy stored in the capacitor. 2
- (iv) Switch **S** is now opened.
Sketch a graph to show how the current through the $220\ \Omega$ resistor varies with time from the moment the switch is opened.
Numerical values are required only on the current axis. 2

(8)

[Turn over

26. A double beam oscilloscope has two inputs which allows two signals to be viewed on the screen at the same time.
- A double beam oscilloscope is connected to the input terminals **P** and **Q** and the output terminals **R** and **S** of a box containing an operational amplifier circuit.
- The operational amplifier is operating in the inverting mode.

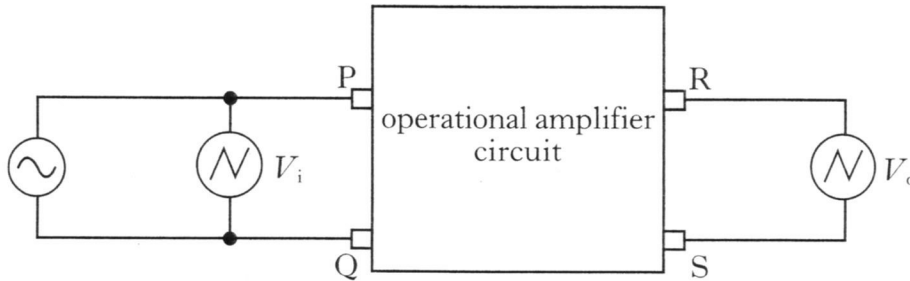

- (a) The oscilloscope control settings and the two traces displayed on its screen are shown in the diagram.

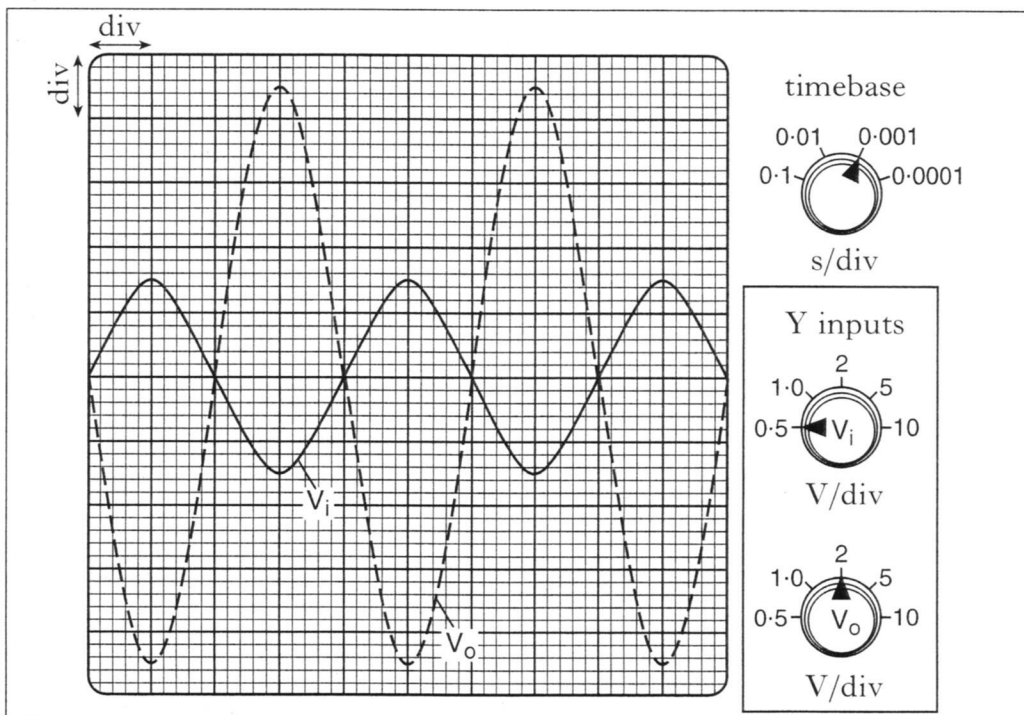

- (i) Calculate the frequency of the a.c. supply. 2
- (ii) Calculate the voltage gain of the amplifier circuit. 2
- (iii) Calculate the r.m.s. value of the output voltage of the amplifier circuit. 2

26. (continued)

(b) A student is given the task of altering the operational amplifier circuit inside the box to give a voltage gain of -4.7 .

The following list shows resistor values available to the student.

Resistor value/ $k\Omega$
3.9
4.7
5.6
6.8
8.2
10
27
47
56

- (i) Select suitable resistor values to produce a voltage gain of -4.7 . 1
- (ii) Copy the diagram shown below.

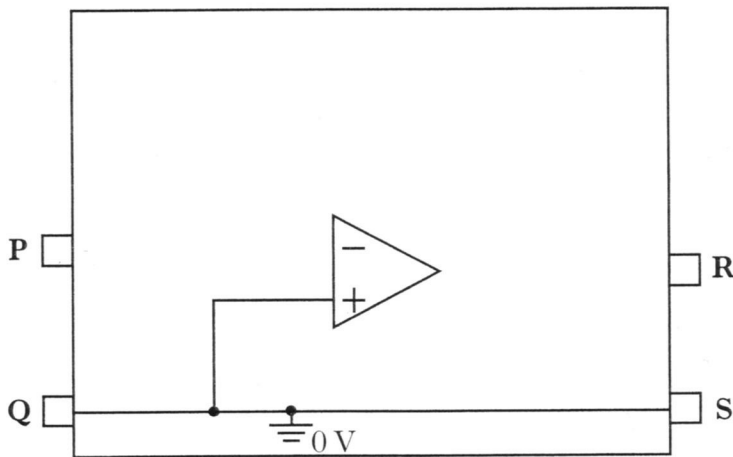

Complete the diagram, showing how your chosen resistors should be connected inside the box to complete the circuit.

1
(8)

[Turn over

27. (a) Light of frequency 6.7×10^{14} Hz is produced at the junction of a light emitting diode (LED).

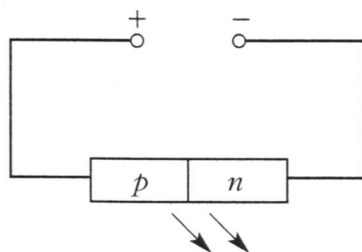

- (i) Describe how the movement of charges in a forward-biased LED produces light. Your description should include the terms: *electrons*; *holes*; *photons* and *junction*. 1
- (ii) (A) Calculate the wavelength of the light emitted from the LED. 2
- (B) Use information from the data sheet on *Page two* to deduce the colour of this light. 1
- (iii) The table below gives the values of the work function for three metals.

<i>Metal</i>	<i>Work function/J</i>
caesium	3.4×10^{-19}
strontium	4.1×10^{-19}
magnesium	5.9×10^{-19}

Light from the LED is now incident on these metals in turn.

Show by calculation which of these metals, if any, release(s) photoelectrons with this light. 3

- (b) Light from a different LED is passed through a grating as shown below.

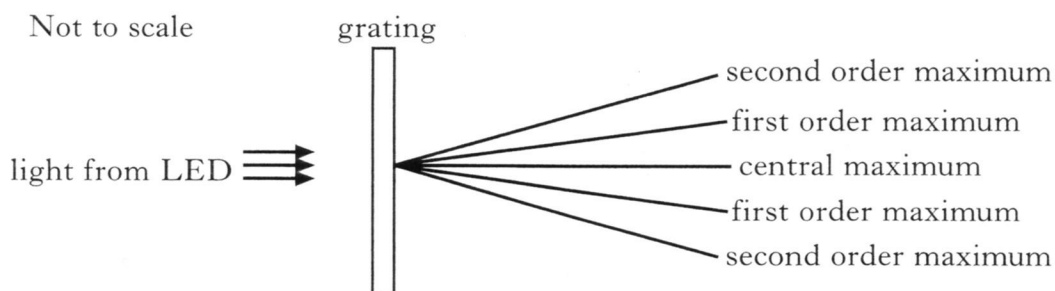

Light from this LED has a wavelength of 6.35×10^{-7} m. The spacing between lines in the grating is 5.0×10^{-6} m.

Calculate the angle between the central maximum and the **second** order maximum. 2

(9)

28. A student carries out an experiment to investigate how irradiance on a surface varies with distance from a small lamp.

Irradiance is measured with a light meter.

The distance between the small lamp and the light meter is measured with a metre stick.

The apparatus is set up as shown in a darkened laboratory.

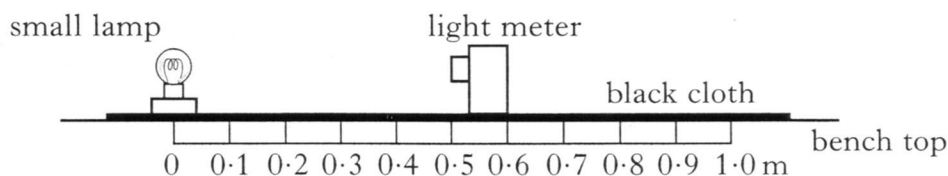

The following results are obtained.

<i>Distance from source/m</i>	0.20	0.30	0.40	0.50
<i>Irradiance/units</i>	675	302	170	108

- (a) What is meant by the term *irradiance*? 1
- (b) Use **all** the data to find the relationship between irradiance I and distance d from the source. 2
- (c) What is the purpose of the black cloth on top of the bench? 1
- (d) The small lamp is replaced by a laser.

Light from the laser is shone on to the light meter.

A reading is taken from the light meter when the distance between it and the laser is 0.50 m.

The distance is now increased to 1.00 m.

State how the new reading on the light meter compares with the one taken at 0.50 m.

Justify your answer. 2

(6)

[Turn over

29. (a) About one hundred years ago Rutherford designed an experiment to investigate the structure of the atom. He used a radioactive source to fire alpha particles at a thin gold foil target.

His two assistants, Geiger and Marsden, spent many hours taking readings from the detector as it was moved to different positions between **X** and **Y**.

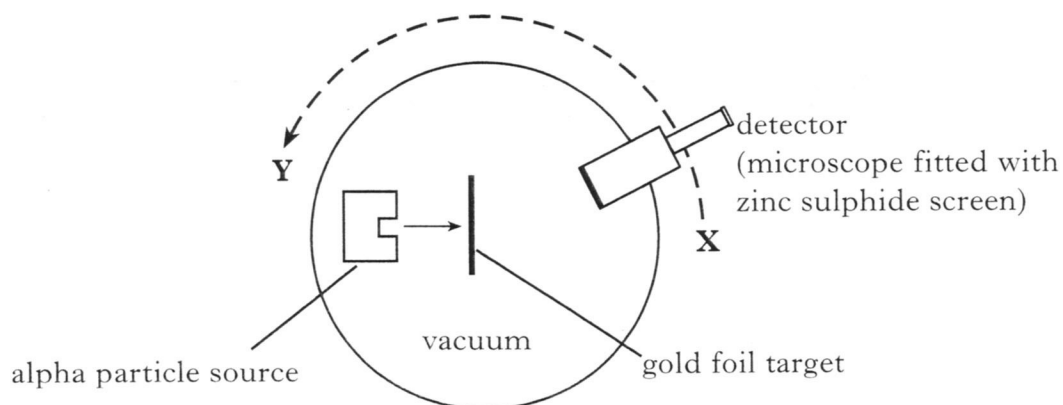

- (i) How did the number of alpha particles detected at **X** compare with the number detected at **Y**? 1
- (ii) State **one** conclusion Rutherford deduced from the results. 1

29. (continued)

(b) A nuclear fission reaction is represented by the following statement.

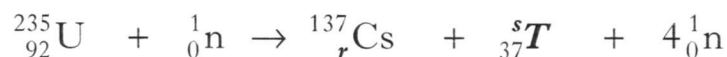

- (i) Is this a spontaneous or an induced reaction? You must justify your answer. 1
- (ii) Determine the numbers represented by the letters *r* and *s* in the above reaction. 1
- (iii) Use the data booklet to identify the element represented by *T*. 1
- (iv) The masses of the nuclei and particles in the reaction are given below.

	Mass/kg
${}_{92}^{235}\text{U}$	390.219×10^{-27}
${}_r^{137}\text{Cs}$	227.292×10^{-27}
${}_{37}^s\text{T}$	157.562×10^{-27}
${}_0^1\text{n}$	1.675×10^{-27}

Calculate the energy released in the reaction.

3
(8)

[END OF QUESTION PAPER]