

X069/301

NATIONAL
QUALIFICATIONS
2005

TUESDAY, 24 MAY
1.00 PM – 3.30 PM

PHYSICS
HIGHER

Read Carefully

- 1 All questions should be attempted.

Section A (questions 1 to 20)

- 2 Check that the answer sheet is for Physics Higher (Section A).
- 3 Check that the answer sheet you have been given has **your name**, **date of birth**, **SCN** (Scottish Candidate Number) and **Centre Name** printed on it.
Do not change any of these details.
- 4 If any of this information is wrong, tell the Invigilator immediately.
- 5 If this information is correct, **print** your name and seat number in the boxes provided.
- 6 Use **black** or **blue ink** for your answers. **Do not use red ink.**
- 7 There is **only one correct** answer to each question.
- 8 Any rough working should be done on the question paper or the rough working sheet, **not** on your answer sheet.
- 9 At the end of the exam, put the **answer sheet for Section A inside the front cover of your answer book.**
- 10 Instructions as to how to record your answers to questions 1–20 are given on page three.

Section B (questions 21 to 30)

- 11 Answer questions numbered 21 to 30 in the answer book provided.
- 12 Fill in the details on the front of the answer book.
- 13 Enter the question number clearly in the margin of the answer book beside each of your answers to questions 21 to 30.
- 14 Care should be taken to give an appropriate number of significant figures in the final answers to calculations.



DATA SHEET
COMMON PHYSICAL QUANTITIES

Quantity	Symbol	Value	Quantity	Symbol	Value
Speed of light in vacuum	c	$3.00 \times 10^8 \text{ m s}^{-1}$	Mass of electron	m_e	$9.11 \times 10^{-31} \text{ kg}$
Magnitude of the charge on an electron	e	$1.60 \times 10^{-19} \text{ C}$	Mass of neutron	m_n	$1.675 \times 10^{-27} \text{ kg}$
Gravitational acceleration on Earth	g	9.8 m s^{-2}	Mass of proton	m_p	$1.673 \times 10^{-27} \text{ kg}$
Planck's constant	h	$6.63 \times 10^{-34} \text{ J s}$			

REFRACTIVE INDICES

The refractive indices refer to sodium light of wavelength 589 nm and to substances at a temperature of 273 K.

Substance	Refractive index	Substance	Refractive index
Diamond	2.42	Water	1.33
Crown glass	1.50	Air	1.00

SPECTRAL LINES

Element	Wavelength/nm	Colour	Element	Wavelength/nm	Colour
Hydrogen	656	Red	Cadmium	644	Red
	486	Blue-green		509	Green
	434	Blue-violet		480	Blue
	410	Violet	<i>Lasers</i>		
	397	Ultraviolet	<i>Element</i>	<i>Wavelength/nm</i>	<i>Colour</i>
	389	Ultraviolet	Carbon dioxide	9550 } 10590 }	Infrared
Sodium	589	Yellow	Helium-neon	633	Red

PROPERTIES OF SELECTED MATERIALS

Substance	Density/ kg m^{-3}	Melting Point/ K	Boiling Point/ K
Aluminium	2.70×10^3	933	2623
Copper	8.96×10^3	1357	2853
Ice	9.20×10^2	273
Sea Water	1.02×10^3	264	377
Water	1.00×10^3	273	373
Air	1.29
Hydrogen	9.0×10^{-2}	14	20

The gas densities refer to a temperature of 273 K and a pressure of $1.01 \times 10^5 \text{ Pa}$.

SECTION A

For questions 1 to 20 in this section of the paper the answer to each question is either A, B, C, D or E. Decide what your answer is, then put a horizontal line in the space provided—see the example below.

EXAMPLE

The energy unit measured by the electricity meter in your home is the

- A ampere
- B kilowatt-hour
- C watt
- D coulomb
- E volt.

The correct answer is **B**—kilowatt-hour. The answer **B** has been clearly marked with a horizontal line (see below).

A	B	C	D	E
<input type="checkbox"/>	<input checked="" type="checkbox"/>	<input type="checkbox"/>	<input type="checkbox"/>	<input type="checkbox"/>

Changing an answer

If you decide to change your answer, cancel your first answer by putting a cross through it (see below) and fill in the answer you want. The answer below has been changed to **B**.

A	B	C	D	E
<input type="checkbox"/>	<input checked="" type="checkbox"/>	<input type="checkbox"/>	<input checked="" type="checkbox"/>	<input type="checkbox"/>

If you then decide to change back to an answer you have already scored out, put a tick (✓) to the **right** of the answer you want, as shown below:

A	B	C	D	E
<input type="checkbox"/>	<input checked="" type="checkbox"/>	<input type="checkbox"/>	<input checked="" type="checkbox"/>	<input type="checkbox"/>

 or

A	B	C	D	E
<input type="checkbox"/>	<input checked="" type="checkbox"/>	<input type="checkbox"/>	<input type="checkbox"/>	<input type="checkbox"/>

[Turn over

SECTION A

Answer questions 1–20 on the answer sheet.

1. A car travels from X to Y and then from Y to Z as shown.

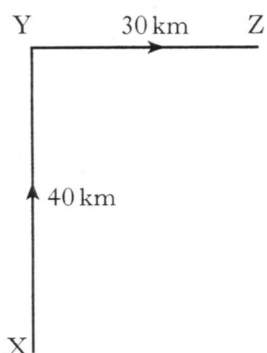

It takes one hour to travel from X to Y. It also takes one hour to travel from Y to Z.

Which row in the following table shows the magnitudes of the displacement, average speed and average velocity for the complete journey?

	<i>Displacement</i> (km)	<i>Average speed</i> (km h ⁻¹)	<i>Average velocity</i> (km h ⁻¹)
A	50	35	25
B	70	35	25
C	50	35	35
D	70	70	50
E	50	70	25

2. An object has a constant acceleration of 3 m s⁻². This means that the
- A distance travelled by the object increases by 3 metres every second
 - B displacement of the object increases by 3 metres every second
 - C speed of the object is 3 m s⁻¹ every second
 - D velocity of the object is 3 m s⁻¹ every second
 - E velocity of the object increases by 3 m s⁻¹ every second.

3. A car of mass 1200 kg pulls a horsebox of mass 700 kg along a straight, horizontal road. They have an acceleration of 2.0 m s⁻².

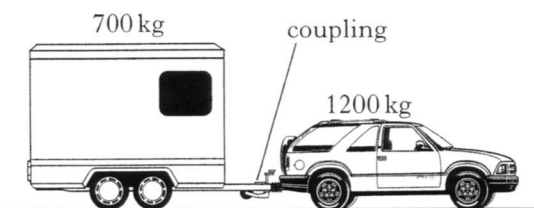

Assuming that the frictional forces are negligible, the tension in the coupling between the car and the horsebox is

- A 500 N
- B 700 N
- C 1400 N
- D 2400 N
- E 3800 N.

4. A mass of 2 kg slides along a frictionless surface at 10 m s⁻¹ and collides with a stationary mass of 10 kg.

before impact

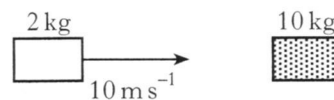

After the collision, the 2 kg mass rebounds at 5 m s⁻¹ and the 10 kg mass moves off at 3 m s⁻¹.

after impact



Which row in the following table is correct?

	<i>Momentum of system</i>	<i>Kinetic energy of system</i>	<i>Type of collision</i>
A	conserved	conserved	elastic
B	conserved	not conserved	inelastic
C	conserved	not conserved	elastic
D	not conserved	not conserved	inelastic
E	not conserved	not conserved	elastic

5. A golfer hits a ball of mass 5.0×10^{-2} kg with a golf club. The ball leaves the tee with a velocity of 80 ms^{-1} . The club is in contact with the ball for a time of 0.10 s.

The average force exerted by the club on the ball is

- A 6.25×10^{-4} N
- B 0.025 N
- C 0.4 N
- D 4 N
- E 40 N.

6. A solid at a temperature of -20°C is heated until it becomes a liquid at 70°C .

The temperature change in kelvin is

- A 50 K
- B 90 K
- C 343 K
- D 363 K
- E 596 K.

7. One volt is

- A one coulomb per joule
- B one joule coulomb
- C one joule per coulomb
- D one joule per second
- E one coulomb per second.

8. A potential difference of 5000 V is applied between two metal plates. The plates are 0.10 m apart. A charge of $+2.0$ mC is released from rest at the positively charged plate as shown.

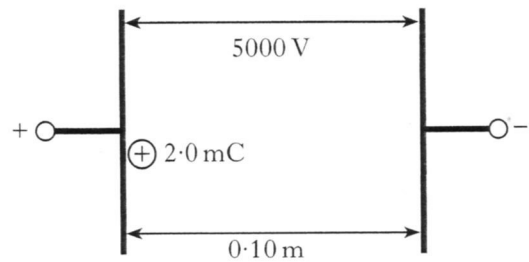

The kinetic energy of the charge just before it hits the negative plate is

- A 4.0×10^{-7} J
- B 2.0×10^{-4} J
- C 5.0 J
- D 10 J
- E 500 J.

9. An a.c. signal is displayed on an oscilloscope screen. The Y-gain and time-base controls are set as shown.

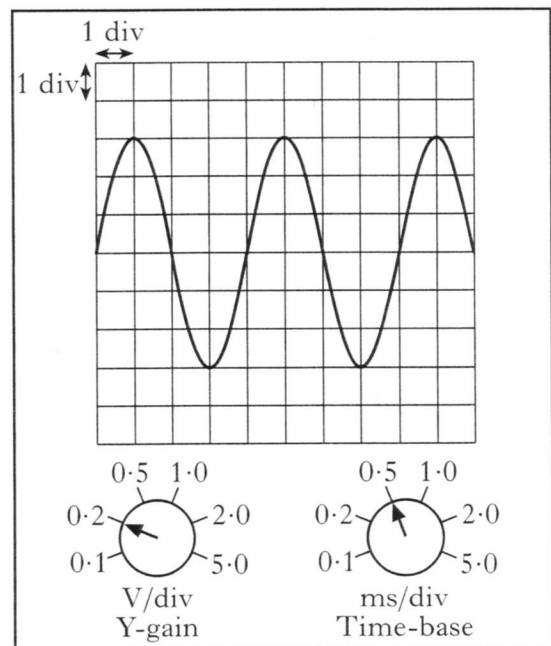

The frequency of the signal is

- A 0.50 Hz
- B 1.25 Hz
- C 2.00 Hz
- D 200 Hz
- E 500 Hz.

10. A capacitor is connected to a circuit as shown.

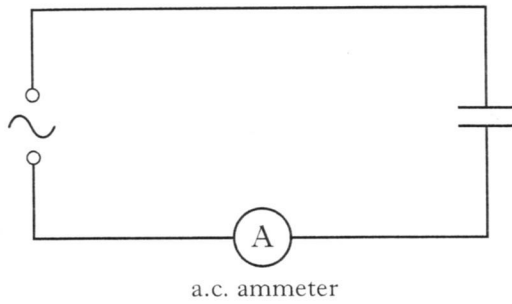

The alternating supply has a constant peak voltage but its frequency can be varied.

The frequency is steadily increased from 50 Hz to 5000 Hz. The reading on the a.c. ammeter

- A remains constant
- B decreases steadily
- C increases steadily
- D increases then decreases
- E decreases then increases.

11. An amplifier circuit is shown.

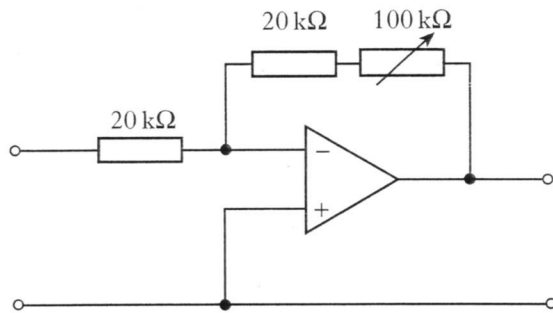

The variable resistor can be adjusted from zero to 100 kΩ. This allows the voltage gain to be altered over the range

- A zero to one
- B zero to five
- C zero to six
- D one to five
- E one to six.

12. A student sets up the following circuit.

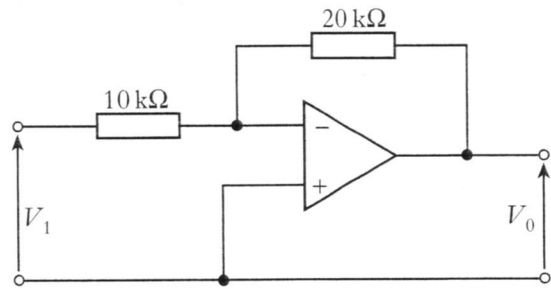

The graph below shows how the input voltage V_1 varies with time.

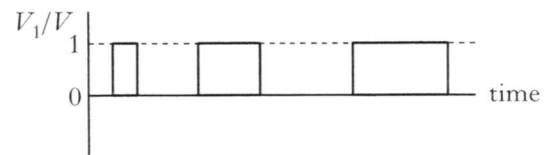

Which of the following graphs shows how the output voltage V_0 varies with time?

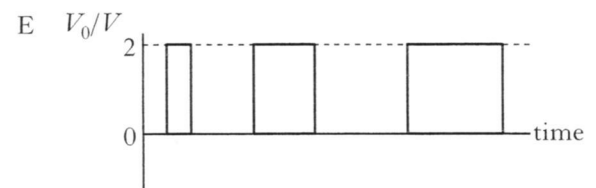
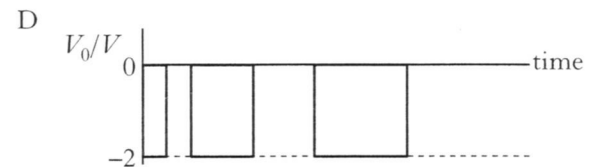
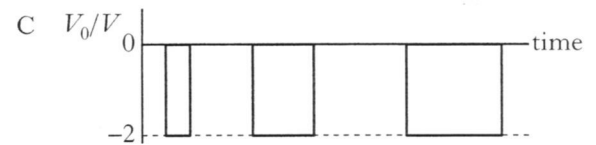
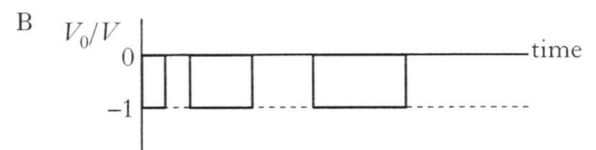
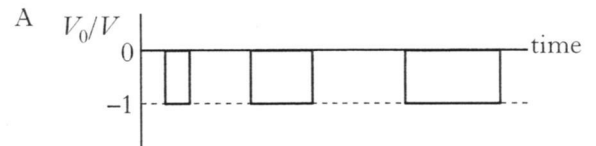

13. The apparatus used to investigate the relationship between light intensity I and distance d from a point source is shown.

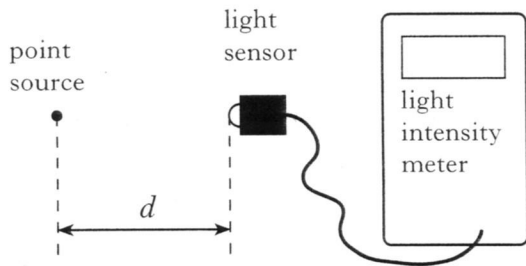

The experiment is carried out in a darkened room.

Which of the following expressions gives a constant value?

- A $I \times d$
 B $I \times d^2$
 C $\frac{I}{d}$
 D $\frac{I}{d^2}$
 E $I \times \sqrt{d}$
14. Microwaves of frequency 2.0×10^{10} Hz travel through air with a speed of 3.0×10^8 m s⁻¹. On entering a bath of oil, the speed reduces to 1.5×10^8 m s⁻¹.
- The frequency of the microwaves in the oil is
- A 1.0×10^{10} Hz
 B 2.0×10^{10} Hz
 C 4.0×10^{10} Hz
 D 3.0×10^{18} Hz
 E 6.0×10^{18} Hz.

15. Which graph shows the relationship between frequency f and wavelength λ of photons of electromagnetic radiation?

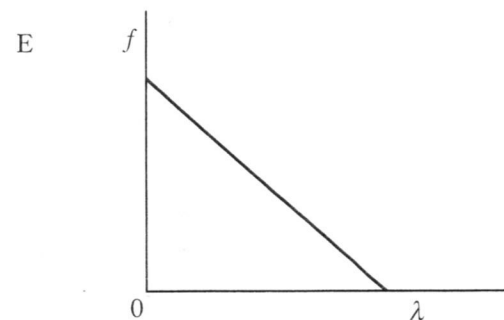
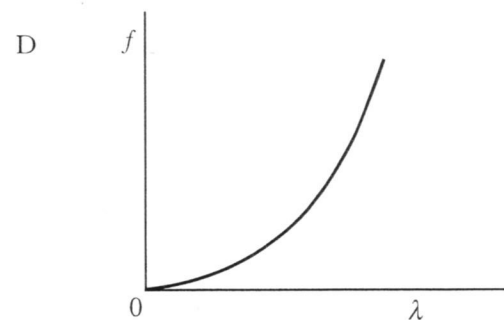
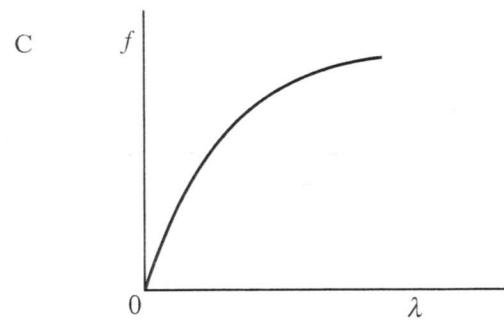
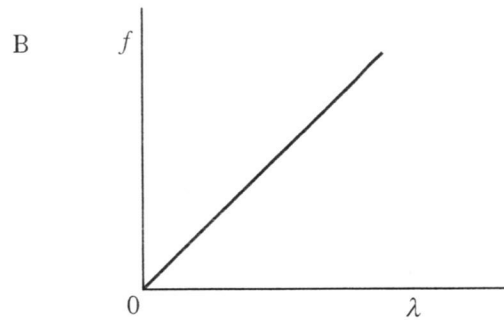
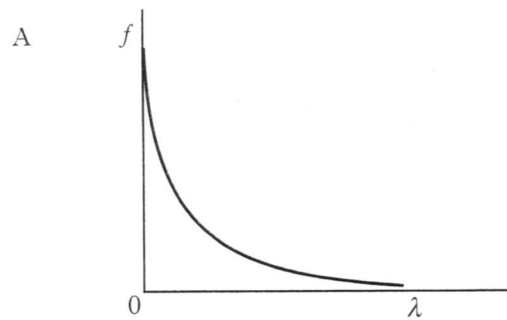

16. A liquid and a solid have the same refractive index.

What happens to the speed and the wavelength of light passing from the liquid into the solid?

	<i>Speed</i>	<i>Wavelength</i>
A	stays the same	stays the same
B	decreases	decreases
C	decreases	increases
D	increases	increases
E	increases	decreases

17. The intensity of light can be measured in

- A W
- B W m^{-1}
- C W m
- D W m^{-2}
- E W m^2 .

18. The diagram below represents part of the process of stimulated emission in a laser.

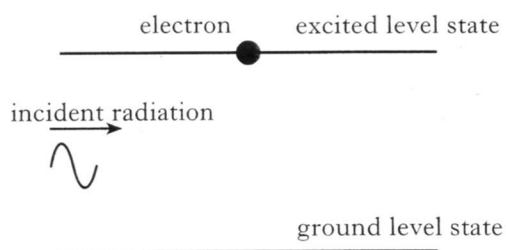

Which of the following statements best describes the emitted radiation?

- A Out of phase and emitted in the same direction as the incident radiation
- B Out of phase and emitted in the opposite direction to the incident radiation
- C In phase and emitted in all directions.
- D In phase and emitted in the same direction as the incident radiation
- E In phase and emitted in the opposite direction to the incident radiation

19. Part of a radioactive decay series is shown.

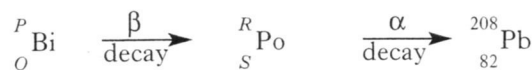

A bismuth nucleus emits a beta particle and its product, a polonium nucleus, emits an alpha particle.

Which numbers are represented by *P*, *Q*, *R* and *S*?

	<i>P</i>	<i>Q</i>	<i>R</i>	<i>S</i>
A	212	85	212	84
B	212	83	212	84
C	212	85	208	83
D	210	83	208	81
E	210	85	210	84

20. The equation below represents a nuclear reaction.

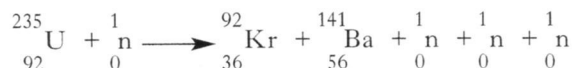

It is an example of

- A nuclear fusion
- B alpha particle emission
- C beta particle emission
- D induced nuclear fission
- E spontaneous nuclear fission.

[SECTION B begins on *Page ten*]

[Turn over

SECTION B

Write your answers to questions 21 to 30 in the answer book.

21. (a) A student uses the apparatus shown to measure the average acceleration of a trolley travelling down a track.

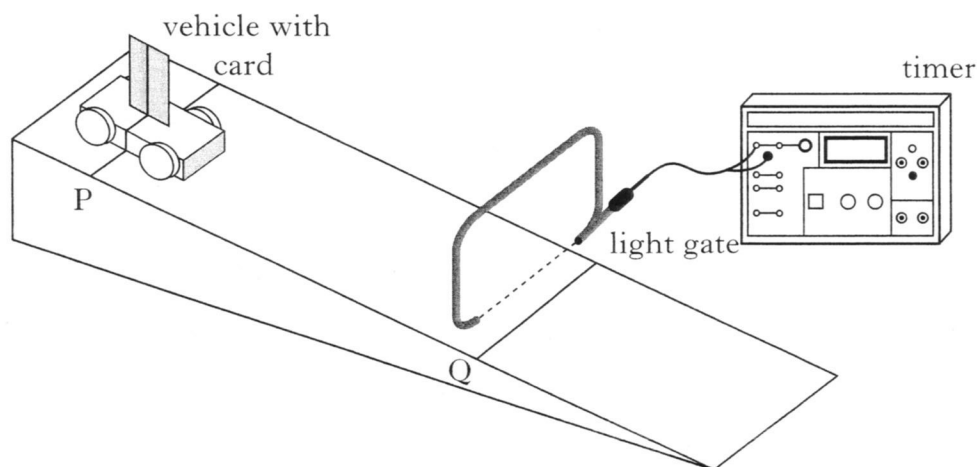

The line on the trolley is aligned with line P on the track.

The trolley is released from rest and allowed to run down the track.

The timer measures the time for the card to pass through the light gate.

This procedure is repeated a number of times and the results shown below.

0.015 s 0.013 s 0.014 s 0.019 s 0.017 s 0.018 s

- (i) Calculate:

(A) the mean time for the card to pass through the light gate; 1

(B) the approximate absolute random uncertainty in this value. 1

- (ii) The length of the card is 0.020 m and the distance PQ is 0.60 m.

Calculate the acceleration of the trolley (an uncertainty in this value is not required). 3

21. (continued)

- (b) The light gate consists of a lamp shining onto a photodiode.
The photodiode forms part of the circuit shown.

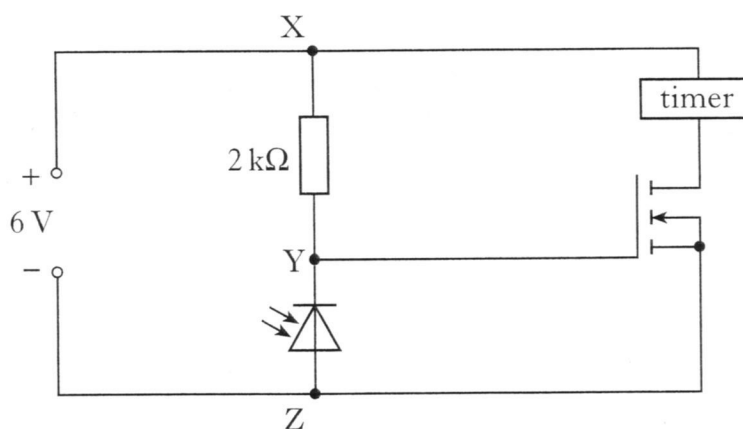

- (i) In which mode is the photodiode operating? 1
- (ii) Explain why the timer only operates while the light beam is broken. 2
- (8)**

[Turn over

22. A “giant catapult” is part of a fairground ride.

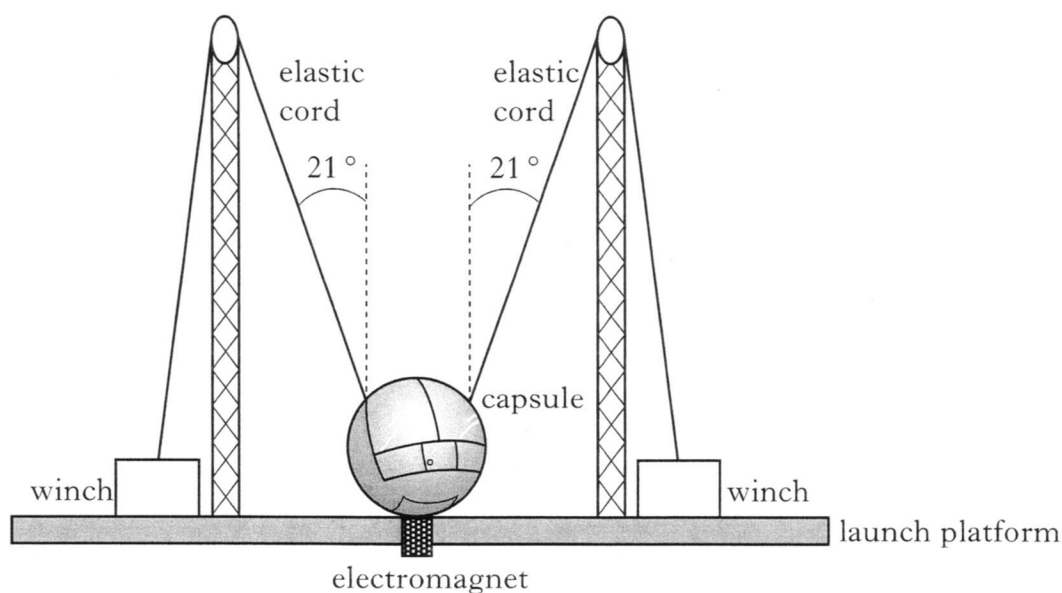

Two people are strapped into a capsule. The capsule and the occupants have a combined mass of 236 kg.

The capsule is held stationary by an electromagnet while the tension in the elastic cords is increased using the winches.

The mass of the elastic cords and the effects of air resistance can be ignored.

(a) When the tension in each cord reaches $4.5 \times 10^3 \text{ N}$ the electromagnet is switched off and the capsule and occupants are propelled vertically upwards.

(i) Calculate the vertical component of the force exerted by **each** cord just before the capsule is released. 1

(ii) Calculate the initial acceleration of the capsule. 3

(iii) Explain why the acceleration of the capsule decreases as it rises. 1

(b) Throughout the ride the occupants remain upright in the capsule.

A short time after release the occupants feel no force between themselves and the seats.

Explain why this happens. 1

(6)

23. A polystyrene float is held with its base 2.0 m below the surface of a swimming pool.

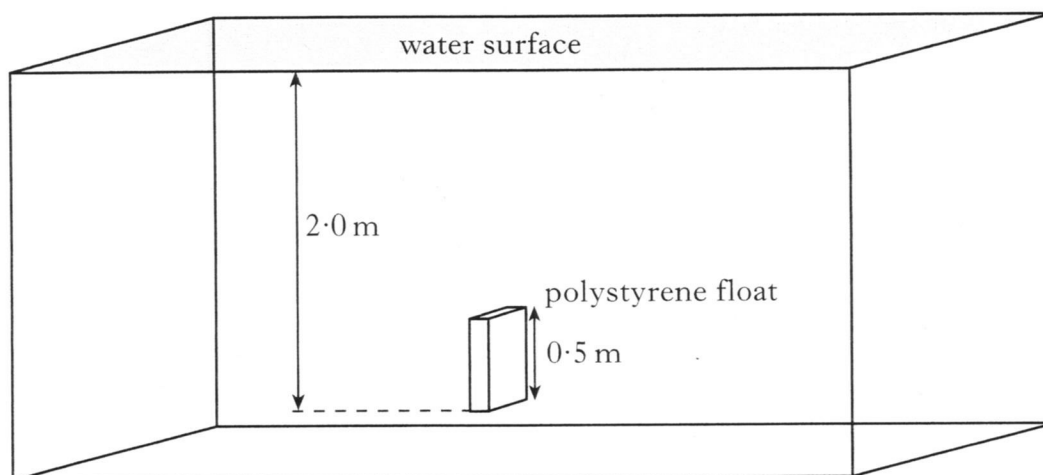

- (a) The float has a mass of 12 g and its dimensions are 0.50 m \times 0.30 m \times 0.10 m. Calculate the density of the float. 2
- (b) Explain why a buoyancy force acts on the float. 2
- (c) The float is released and accelerates towards the surface. Taking into account the resistance of the water, state what happens to the acceleration of the float as it approaches the surface. You must justify your answer. 2
- (d) Another float made of a more dense material with the same dimensions is now held at the same position in the pool.

The float is released as in part (c).

State how the initial acceleration of this float compares with the polystyrene float. You must justify your answer. 1

(7)

[Turn over

24. The apparatus used to investigate the relationship between volume and temperature of a fixed mass of air is shown.

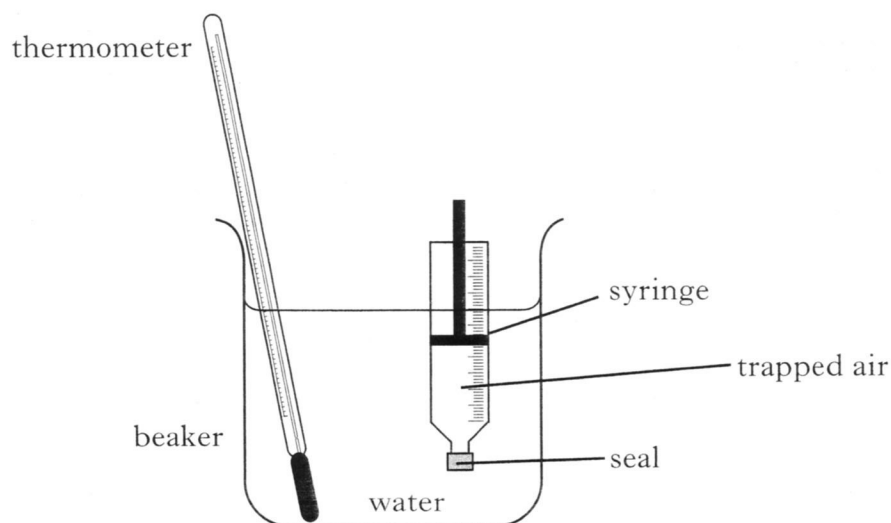

The volume of the trapped air is read from the scale on the syringe.

The temperature of the trapped air is altered by heating the water in the beaker. It is assumed that the temperature of the air in the syringe is the same as that of the surrounding water. The pressure of the trapped air is constant during the investigation.

- (a) Readings of volume and temperature for the trapped air are shown.

<i>Temperature/°C</i>	25	50	75	100
<i>Volume/ml</i>	20.6	22.6	24.0	25.4

- (i) Using **all** the data, establish the relationship between temperature and volume for the trapped air. 2
- (ii) Calculate the volume of the trapped air when the temperature of the water is 65 °C. 2
- (iii) Use the kinetic model of gases to explain the change in volume as the temperature increases in this investigation. 2

24. (continued)

- (b) An alternative to measuring the volume using the scale on the syringe, is to connect the piston of the syringe to a variable resistor.

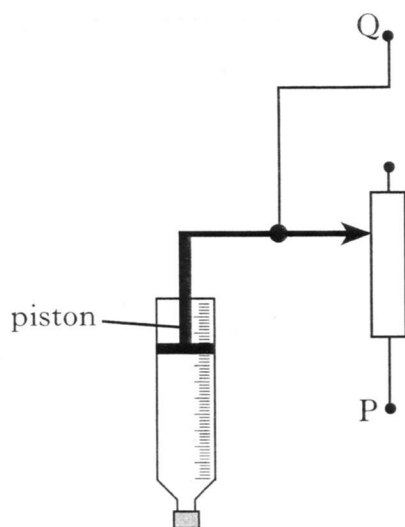

The variable resistor forms part of the circuit shown.

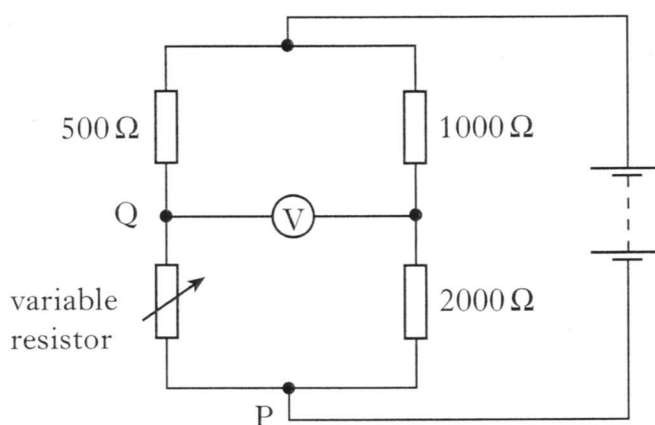

The reading on the voltmeter is 0 V when the temperature of the air in the syringe is 50 °C.

- (i) Calculate the resistance of the variable resistor at this temperature. 2
- (ii) The temperature of the gas in the syringe changes from just below to just above 50 °C. This causes the resistance of the variable resistor to change by a small amount.

Sketch a graph of the reading on the centre-zero voltmeter against the change in resistance of the variable resistor. Numerical values are not required on either axis.

1
(9)

[Turn over

25. A student sets up the following circuit to find the e.m.f. E and the internal resistance r of a battery.

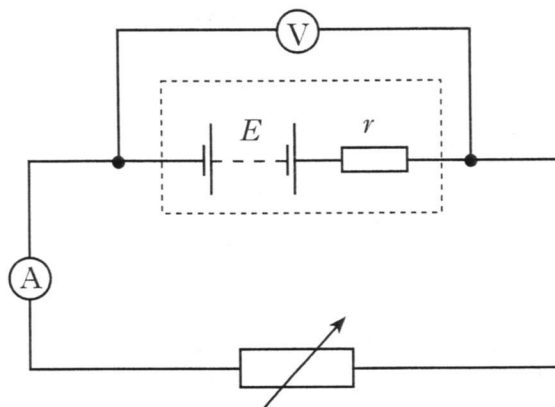

Readings from the voltmeter and ammeter are used to plot the following graph.

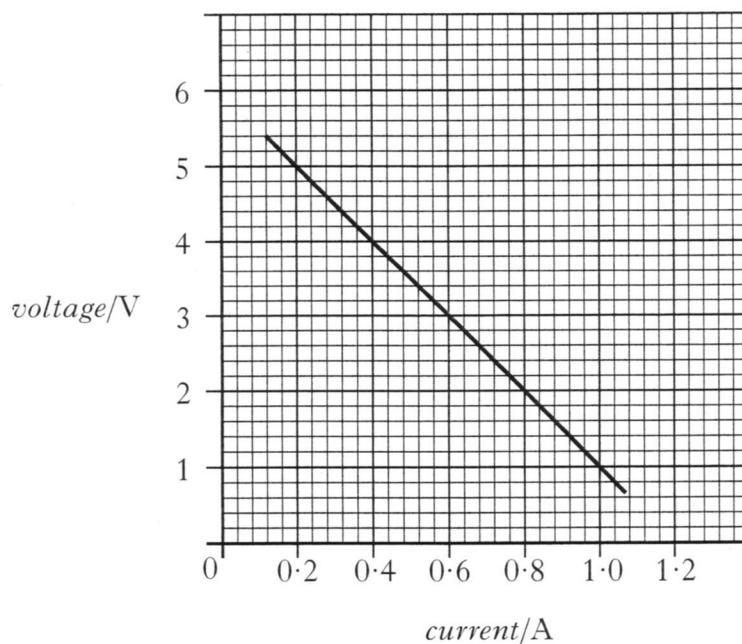

- (a) What is meant by the term *e.m.f.*? 1
- (b) (i) Use the graph to determine:
- (A) the e.m.f.; 1
- (B) the internal resistance of the battery. 2
- (ii) Show that the variable resistor has a value of $15\ \Omega$ when the current is $0.30\ \text{A}$. 1

25. (continued)

- (c) Without adjusting the variable resistor, a $30\ \Omega$ resistor is connected in parallel with it.

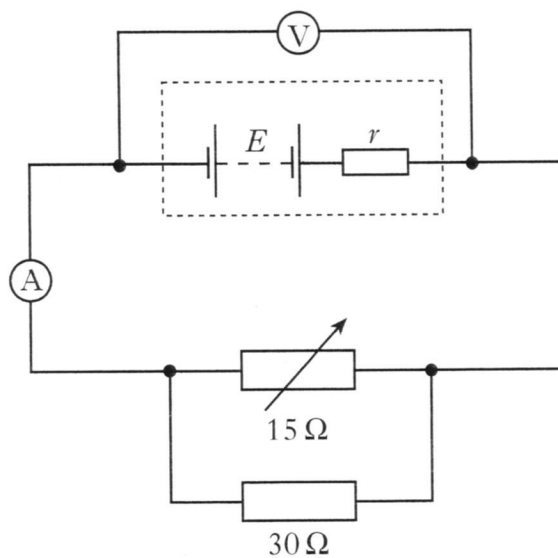

Calculate the new reading on the ammeter.

2
(7)

[Turn over

26. A student investigates the charging and discharging of a $2200\ \mu\text{F}$ capacitor using the circuit shown.

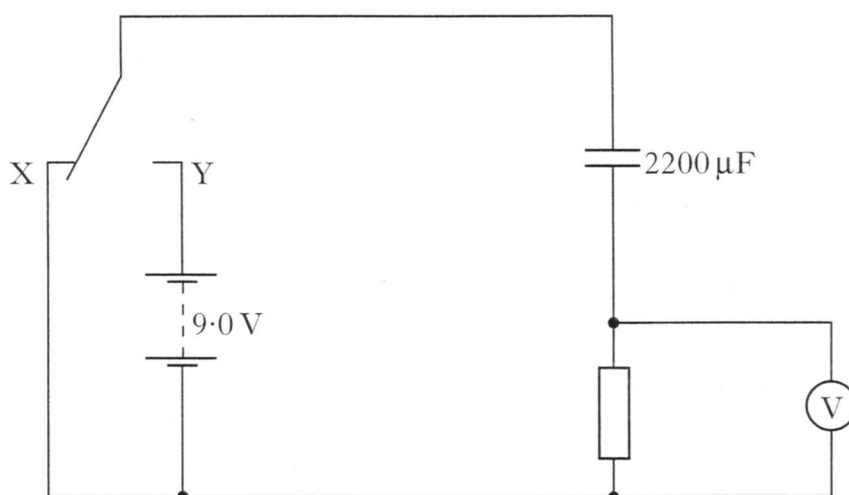

The $9.0\ \text{V}$ battery has negligible internal resistance.

Initially the capacitor is uncharged and the switch is at position X.

The switch is then moved to position Y and the capacitor charges fully in $1.5\ \text{s}$.

- (a) (i) Sketch a graph of the p.d. across the **resistor** against time while the capacitor charges. Appropriate numerical values are required on both axes. 2
- (ii) The resistor is replaced with one of higher resistance. Explain how this affects the time taken to fully charge the capacitor. 1
- (iii) At one instant during the charging of the capacitor the reading on the voltmeter is $4.0\ \text{V}$. Calculate the charge stored by the capacitor at this instant. 3
- (b) Using the same circuit in a later investigation the resistor has a resistance of $100\ \text{k}\Omega$. The switch is in **position Y** and the capacitor is fully charged.
- (i) Calculate the maximum energy stored in the capacitor. 2
- (ii) The switch is moved to position X. Calculate the maximum current in the resistor. 2
- (10)**

27. A car is fitted with an alarm which sounds a buzzer when the outside temperature falls below 3°C .

The sensor is a thermistor located under the mirror on the side of the car.

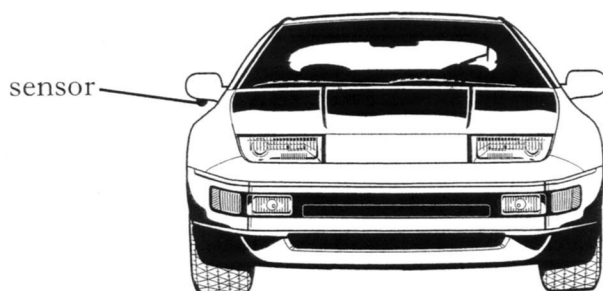

The thermistor forms part of the circuit shown.

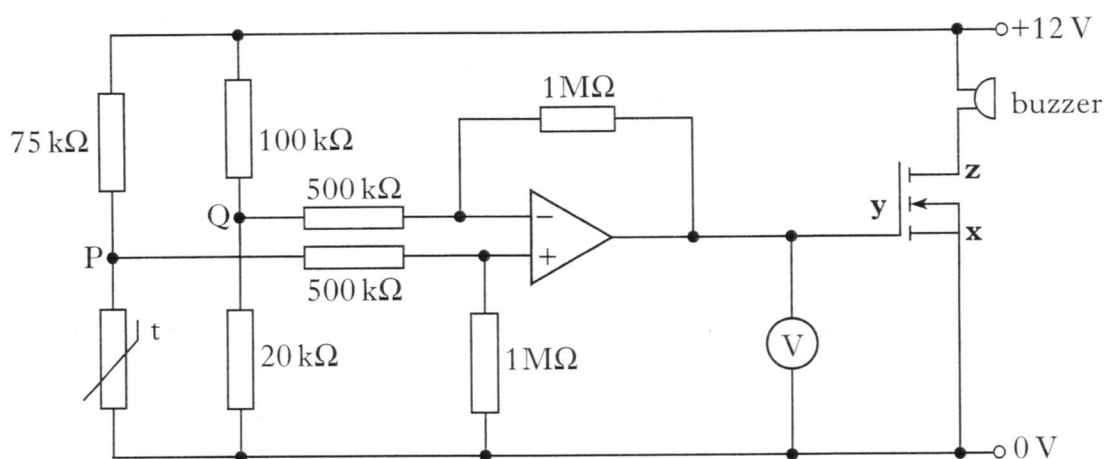

- (a) What names are given to the terminals labelled **x**, **y** and **z** on the symbol for the MOSFET?

Clearly indicate which name goes with which letter.

1

- (b) The buzzer sounds when the reading on the voltmeter is greater than or equal to $+2.0\text{ V}$.

- (i) Calculate the minimum potential difference required between points P and Q to sound the buzzer.
- (ii) Calculate the resistance of the thermistor when the reading on the voltmeter is $+2.0\text{ V}$.

2

2
(5)

[Turn over

28. A physics student investigates what happens when monochromatic light passes through a glass prism or a grating.

(a) The apparatus for the first experiment is shown below.

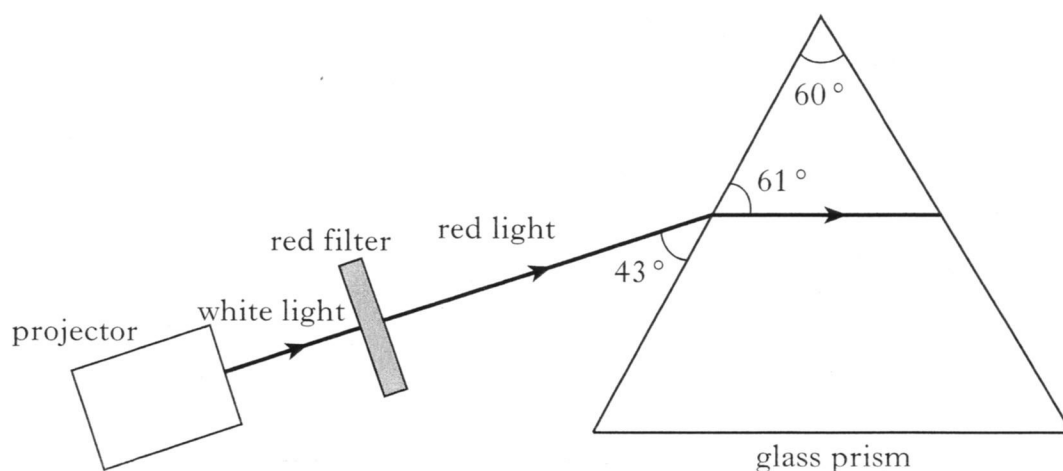

- (i) Calculate the refractive index of the glass for the red light. 2
- (ii) Sketch a diagram which shows the ray of red light before, during and after passing through the prism. Mark on your diagram the values of all relevant angles. 2

(b) The apparatus for the second experiment is shown below.

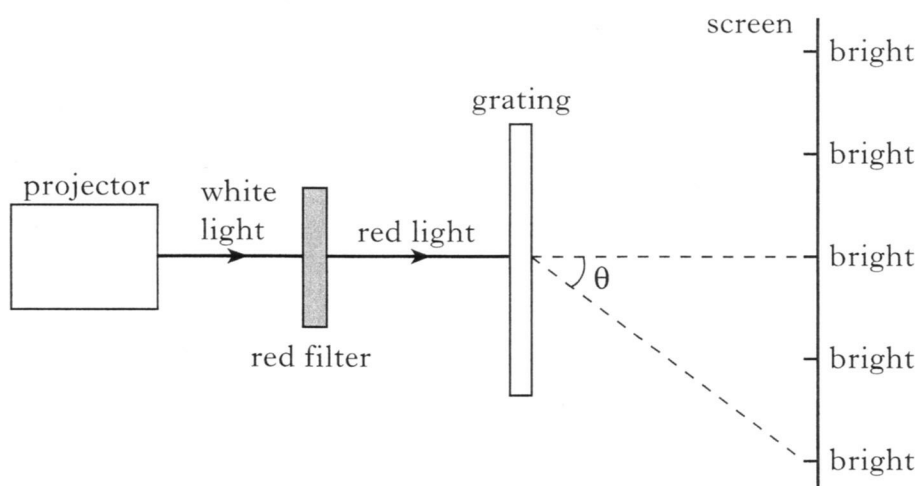

A pattern of bright and dark fringes is observed on the screen.

The grating has 300 lines per millimetre and the wavelength of the red light is 650 nm.

- (i) Explain how the bright fringes are produced. 1
- (ii) Calculate the angle θ of the second order maximum. 2
- (iii) The red filter is replaced by a blue filter. Describe the effect of this change on the pattern observed. 1
- Justify your answer. 1

(8)

29. In 1902, P. Lenard set up an experiment similar to the one shown below.

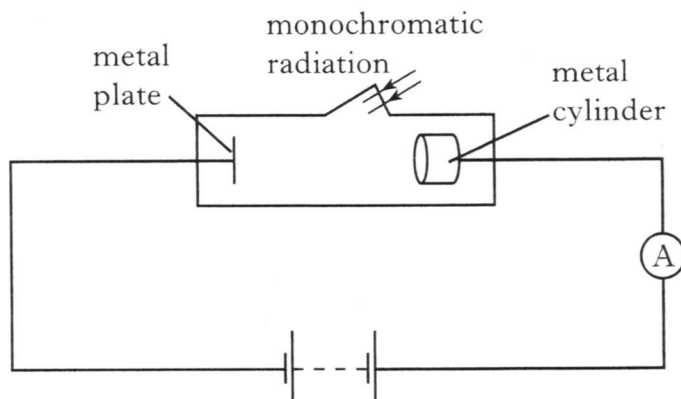

There is a constant potential difference between the metal plate and the metal cylinder.

Monochromatic radiation is directed onto the plate.

Photoelectrons produced at the plate are collected by the cylinder.

The frequency and the intensity of the radiation can be altered independently.

The frequency of the radiation is set at a value above the threshold frequency.

(a) The intensity of the radiation is slowly increased.

Sketch a graph of the current against intensity of radiation.

1

(b) The metal of the plate has a work function of 3.11×10^{-19} J. The wavelength of the radiation is 400 nm.

(i) Calculate the maximum kinetic energy of a photoelectron.

3

(ii) The battery connections are now reversed.

Explain why there could still be a reading on the ammeter.

1
(5)

[Turn over

30. The nuclear industry must meet health and safety standards for workers. A worker has to handle radioactive materials behind a screen.

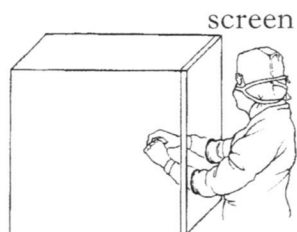

- (a) The screen must be sufficiently thick to reduce the radiation to an acceptable level.

Different thicknesses of the screen material are placed between the source and the Geiger-Muller tube.

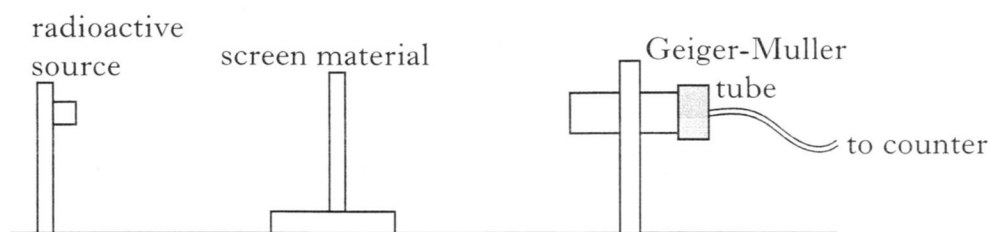

The graph shows corrected count rate plotted against thickness of material.

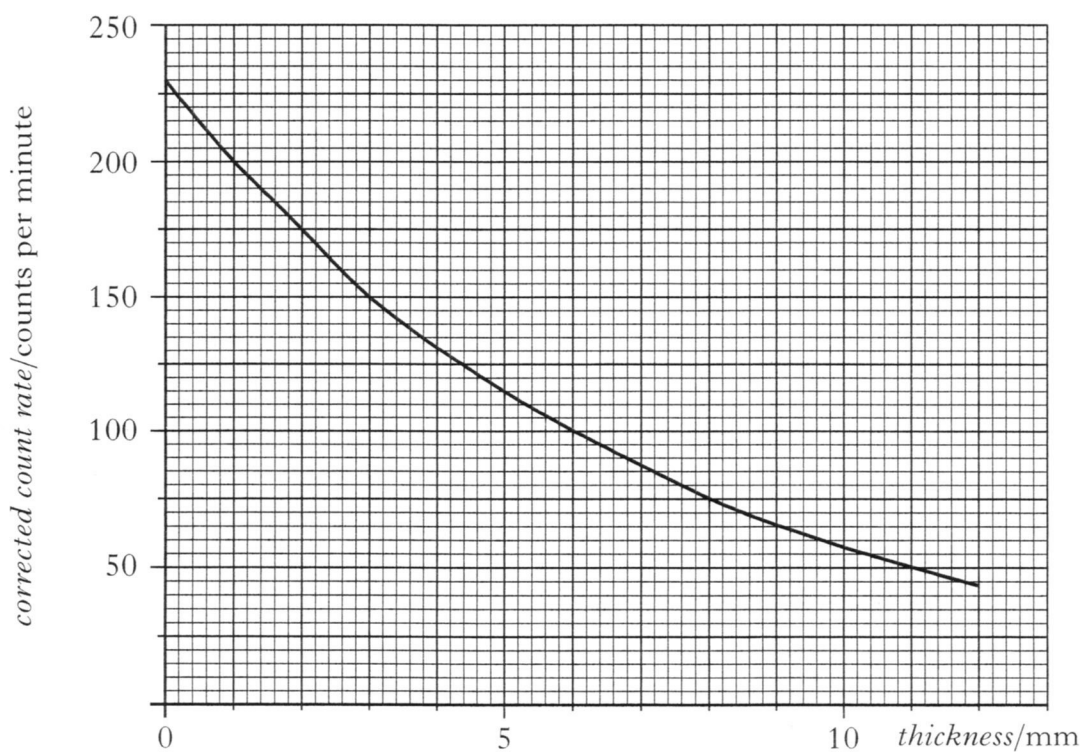

- (i) Determine the half-value thickness of the material. 1
- (ii) The dose equivalent rate in air a short distance from this source is $20 \mu\text{Sv h}^{-1}$.

When a certain thickness of the material is placed in front of the source, the dose equivalent rate at the same distance falls to $2.5 \mu\text{Sv h}^{-1}$.

Calculate the thickness of the material. 2

30. (continued)

- (b) The recommended dose equivalent limit for exposure to the hands of a worker is 500 mSv per year.

On average the worker is exposed to 2.0 mGy of gamma radiation, 400 μ Gy of thermal neutrons and 80 μ Gy of fast neutrons each hour when working in this area.

The quality factors for these radiations are shown.

<i>Radiation</i>	<i>Quality factor</i>
gamma	1
thermal neutrons	3
fast neutrons	10

The recommended dose equivalent limit must not be exceeded.

Calculate the maximum number of working hours in one year permitted in this area.

2
(5)

[END OF QUESTION PAPER]