

# X069/301

---

NATIONAL  
QUALIFICATIONS  
2003

MONDAY, 19 MAY  
1.00 PM – 3.30 PM

PHYSICS  
HIGHER

## Read Carefully

- 1 All questions should be attempted.

## Section A (questions 1 to 20)

- 2 Check that the answer sheet is for Physics Higher (Section A).
- 3 Answer the questions numbered 1 to 20 on the answer sheet provided.
- 4 Fill in the details required on the answer sheet.
- 5 Rough working, if required, should be done only on this question paper, or on the first two pages of the answer book provided—**not** on the answer sheet.
- 6 For each of the questions 1 to 20 there is only **one** correct answer and each is worth 1 mark.
- 7 Instructions as to how to record your answers to questions 1–20 are given on page three.

## Section B (questions 21 to 29)

- 8 Answer questions numbered 21 to 29 in the answer book provided.
- 9 Fill in the details on the front of the answer book.
- 10 Enter the question number clearly in the margin of the answer book beside each of your answers to questions 21 to 29.
- 11 Care should be taken to give an appropriate number of significant figures in the final answers to calculations.

**DATA SHEET**

**COMMON PHYSICAL QUANTITIES**

<i>Quantity</i>	<i>Symbol</i>	<i>Value</i>	<i>Quantity</i>	<i>Symbol</i>	<i>Value</i>
Speed of light in vacuum	$c$	$3.00 \times 10^8 \text{ m s}^{-1}$	Mass of electron	$m_e$	$9.11 \times 10^{-31} \text{ kg}$
Magnitude of the charge on an electron	$e$	$1.60 \times 10^{-19} \text{ C}$	Mass of neutron	$m_n$	$1.675 \times 10^{-27} \text{ kg}$
Gravitational acceleration on Earth	$g$	$9.8 \text{ m s}^{-2}$	Mass of proton	$m_p$	$1.673 \times 10^{-27} \text{ kg}$
Planck's constant	$h$	$6.63 \times 10^{-34} \text{ J s}$			

**REFRACTIVE INDICES**

The refractive indices refer to sodium light of wavelength 589 nm and to substances at a temperature of 273 K.

<i>Substance</i>	<i>Refractive index</i>	<i>Substance</i>	<i>Refractive index</i>
Diamond	2.42	Water	1.33
Crown glass	1.50	Air	1.00

**SPECTRAL LINES**

<i>Element</i>	<i>Wavelength/nm</i>	<i>Colour</i>	<i>Element</i>	<i>Wavelength/nm</i>	<i>Colour</i>
Hydrogen	656	Red	Cadmium	644	Red
	486	Blue-green		509	Green
	434	Blue-violet		480	Blue
	410	Violet	<i>Lasers</i>		
	397	Ultraviolet	<i>Element</i>	<i>Wavelength/nm</i>	<i>Colour</i>
	389	Ultraviolet	Carbon dioxide	9550 } 10590 }	Infrared
Sodium	589	Yellow	Helium-neon	633	Red

**PROPERTIES OF SELECTED MATERIALS**

<i>Substance</i>	<i>Density/ kg m<sup>-3</sup></i>	<i>Melting Point/ K</i>	<i>Boiling Point/ K</i>
Aluminium	$2.70 \times 10^3$	933	2623
Copper	$8.96 \times 10^3$	1357	2853
Ice	$9.20 \times 10^2$	273	....
Sea Water	$1.02 \times 10^3$	264	377
Water	$1.00 \times 10^3$	273	373
Air	1.29	....	....
Hydrogen	$9.0 \times 10^{-2}$	14	20

The gas densities refer to a temperature of 273 K and a pressure of  $1.01 \times 10^5 \text{ Pa}$ .

SECTION A

For questions 1 to 20 in this section of the paper, an answer is recorded on the answer sheet by indicating the choice A, B, C, D or E by a stroke made in ink in the appropriate box of the answer sheet—see the example below.

EXAMPLE

The energy unit measured by the electricity meter in your home is the

- A ampere
- B kilowatt-hour
- C watt
- D coulomb
- E volt.

The correct answer to the question is B—kilowatt-hour. Record your answer by drawing a heavy vertical line joining the two dots in the appropriate box on your answer sheet in the column of boxes headed B. The entry on your answer sheet would now look like this:

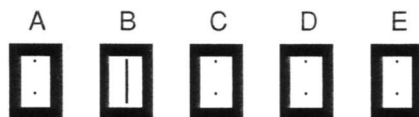

If after you have recorded your answer you decide that you have made an error and wish to make a change, you should cancel the original answer and put a vertical stroke in the box you now consider to be correct. Thus, if you want to change an answer D to an answer B, your answer sheet would look like this:

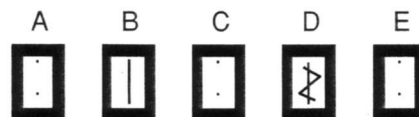

If you want to change back to an answer which has already been scored out, you should enter a tick (✓) to the RIGHT of the box of your choice, thus:

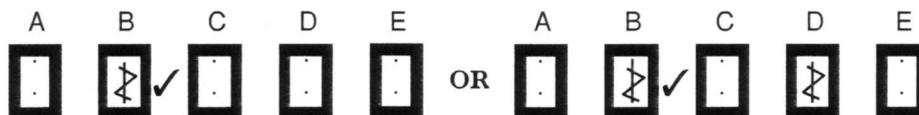

SECTION A

Answer questions 1–20 on the answer sheet.

1. Which of the following are **both** vectors?

- A Speed and weight
- B Kinetic energy and potential energy
- C Mass and momentum
- D Weight and momentum
- E Force and speed

2. A vehicle is travelling in a straight line.

Graphs of velocity and acceleration against time are shown below.

Which pair of graphs could represent the motion of the vehicle?

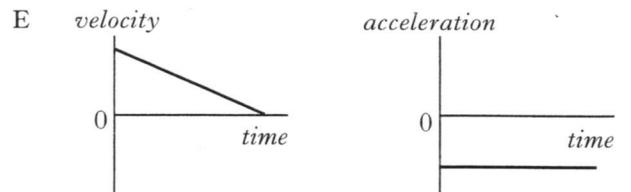
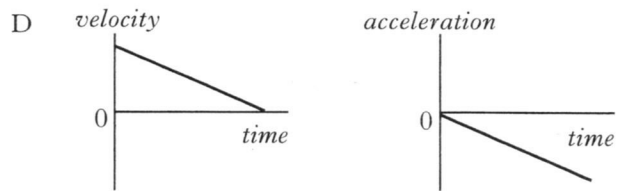
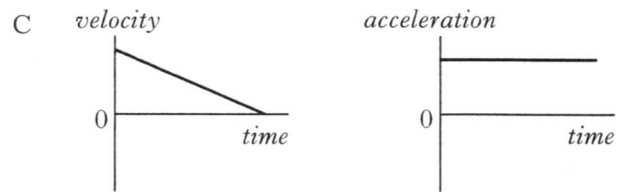
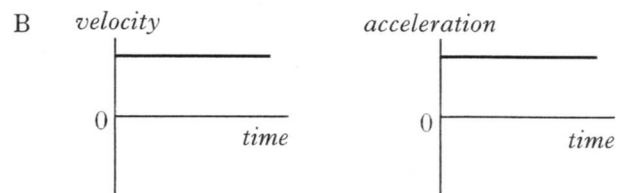
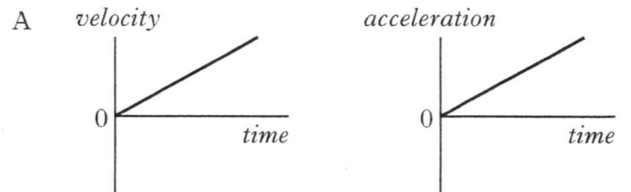



3. A block of mass 4.0 kg and a block of mass 6.0 kg are linked by a spring balance of negligible mass.

The blocks are placed on a frictionless horizontal surface. A force of 18.0 N is applied to the 6.0 kg block as shown.

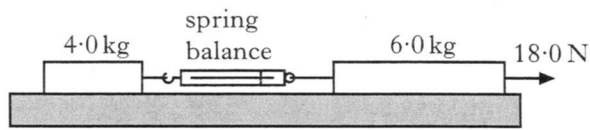

What is the reading on the spring balance?

- A 7.2 N
  - B 9.0 N
  - C 10.8 N
  - D 18.0 N
  - E 40.0 N
4. A car of mass 1000 kg is travelling at a speed of  $40 \text{ m s}^{-1}$  along a straight road. The brakes are applied and the car decelerates to  $10 \text{ m s}^{-1}$ .

How much kinetic energy is lost by the car?

- A 15 kJ
  - B 50 kJ
  - C 450 kJ
  - D 750 kJ
  - E 800 kJ
5. A car is designed with a “crumple-zone” so that the front of the car collapses during impact.

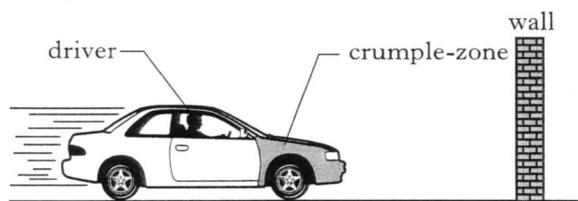

The purpose of the crumple-zone is to

- A decrease the driver's change in momentum per second
- B increase the driver's change in momentum per second
- C decrease the driver's final velocity
- D increase the driver's total change in momentum
- E decrease the driver's total change in momentum.

6. A fixed mass of gas condenses at atmospheric pressure to form a liquid.

Which row in the table shows the approximate increase in density and the approximate decrease in spacing between molecules?

	<i>Approximate increase in density</i>	<i>Approximate decrease in spacing between molecules</i>
A	10 times	2 times
B	100 times	10 times
C	1000 times	10 times
D	1 000 000 times	100 times
E	1 000 000 times	1000 times

[Turn over

7. A rigid metal cylinder stores compressed gas. Gas is gradually released from the cylinder. The temperature of the gas remains constant.

Which set of graphs shows how the pressure, the volume and the mass of the gas **in the cylinder** change with time?

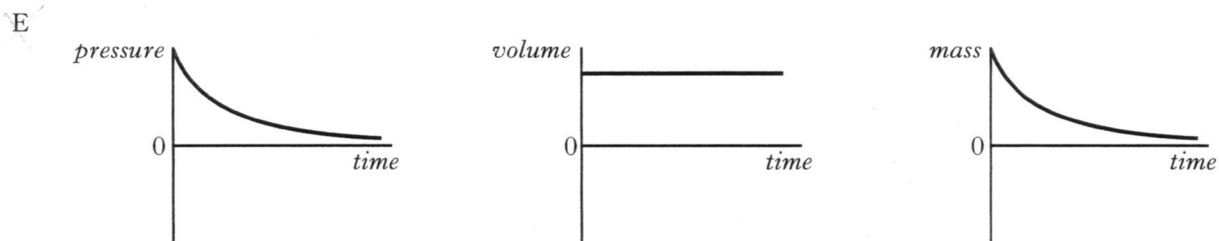
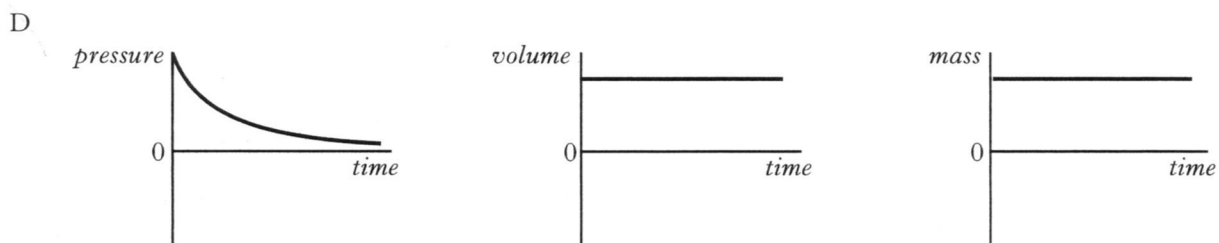
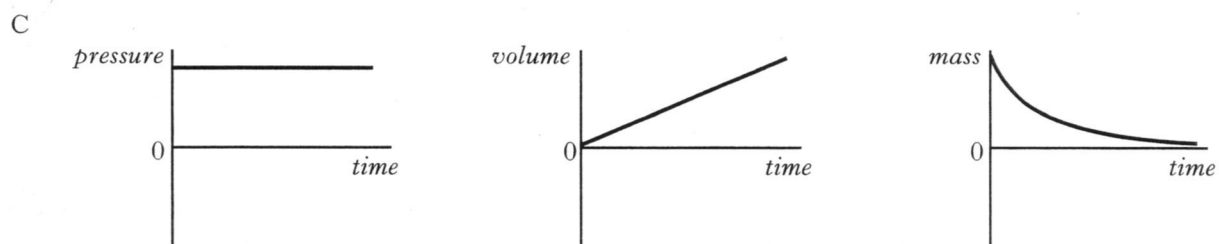
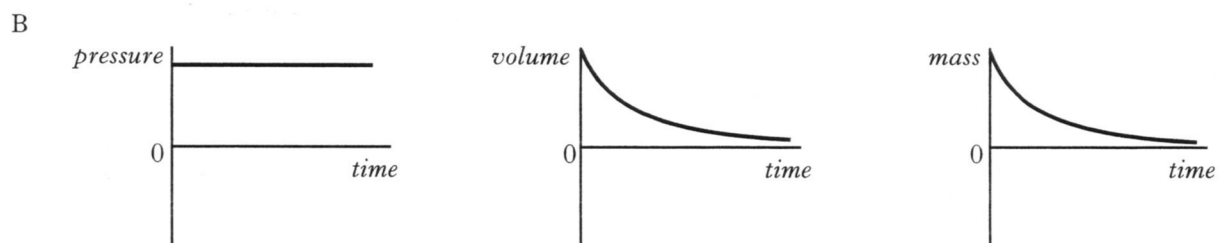
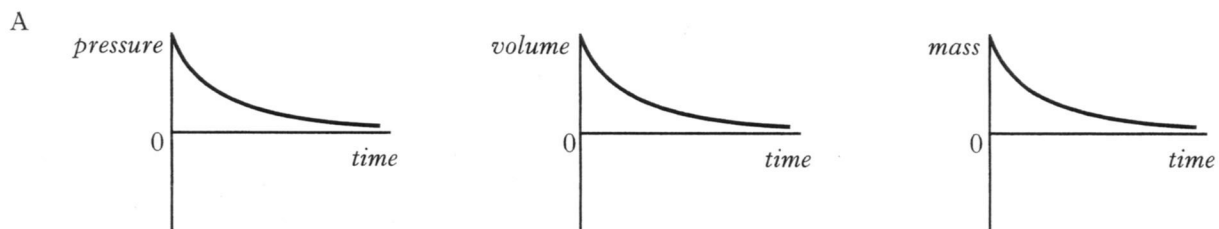

8. Two parallel metal plates, R and S, are connected to a 2.0 V d.c. supply as shown.

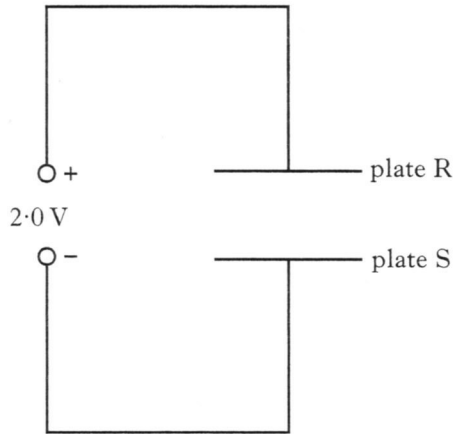

An electron is moved from plate R to plate S.

The gain in electrical potential energy of the electron is

- A  $8.0 \times 10^{-20}$  J  
 B  $1.6 \times 10^{-19}$  J  
 C  $3.2 \times 10^{-19}$  J  
 D  $6.4 \times 10^{-19}$  J  
 E  $1.3 \times 10^{-19}$  J.
9. In the following circuit, the battery has an e.m.f. of 8.0 V and an internal resistance of  $0.20 \Omega$ .

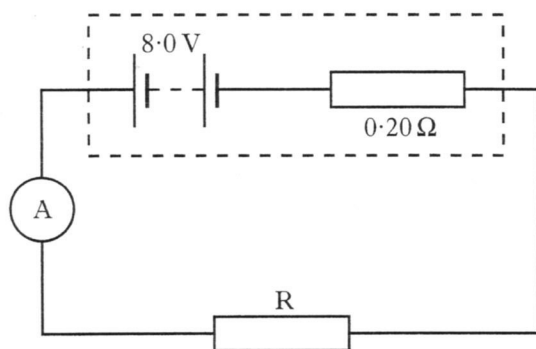

The reading on the ammeter is 4.0 A.

The resistance of R is

- A  $0.5 \Omega$   
 B  $1.8 \Omega$   
 C  $2.0 \Omega$   
 D  $2.2 \Omega$   
 E  $6.4 \Omega$ .

10. In the following circuit, the supply has negligible internal resistance.

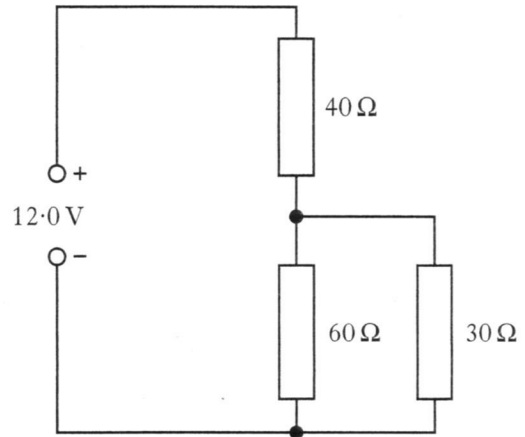

The p.d. across the  $30 \Omega$  resistor is

- A 8.0 V  
 B 7.2 V  
 C 6.0 V  
 D 4.8 V  
 E 4.0 V.

11. A student sets up the following circuit.

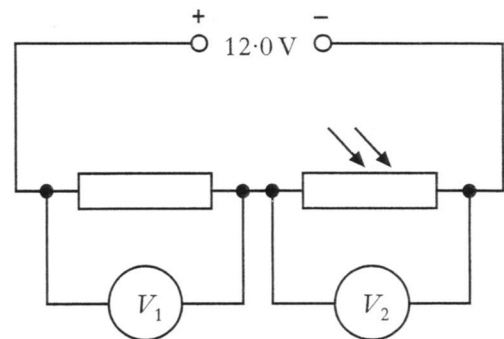

The intensity of light incident on the LDR is reduced.

Which row in the table shows the effect on the voltmeter readings  $V_1$  and  $V_2$ ?

	$V_1$	$V_2$
A	increases	increases
B	decreases	decreases
C	increases	decreases
D	decreases	increases
E	no change	increases

12. A student writes the following statements about a capacitor.

I The current in a circuit containing a capacitor decreases when the supply frequency increases.

II A capacitor can store charge.

III A capacitor can block d.c.

Which of these is/are correct?

- A I only
- B II only
- C III only
- D I and II only
- E II and III only

13. A farad is a

- A volt per ampere
- B volt per ohm
- C coulomb per volt
- D coulomb per second
- E joule per coulomb.

14. A  $10\mu\text{F}$  capacitor is connected to a 50 V supply. The maximum charge stored by the capacitor is

- A  $2.0 \times 10^{-7} \text{ C}$
- B  $5.0 \times 10^{-4} \text{ C}$
- C 5.0 C
- D  $5.0 \times 10^2 \text{ C}$
- E  $5.0 \times 10^6 \text{ C}$ .

15. In the following passage three words have been replaced by the letters **X**, **Y** and **Z**.

*“Monochromatic light is incident on a grating and the resulting interference pattern is viewed on a screen. The distance between neighbouring areas of constructive interference on the screen:*

*is .....**X**..... when the screen is moved further away from the grating;*

*is .....**Y**..... when light of a greater wavelength is used;*

*is .....**Z**..... when the distance between the slits is increased.”*

Which row of the table shows the missing words?

	<b>X</b>	<b>Y</b>	<b>Z</b>
A	increased	increased	increased
B	increased	increased	decreased
C	decreased	decreased	increased
D	decreased	decreased	decreased
E	increased	decreased	decreased

16. An engineer creates an experimental window using sheets of transparent plastics **P**, **Q** and **R**.

A ray of light directed at the window follows the path shown.

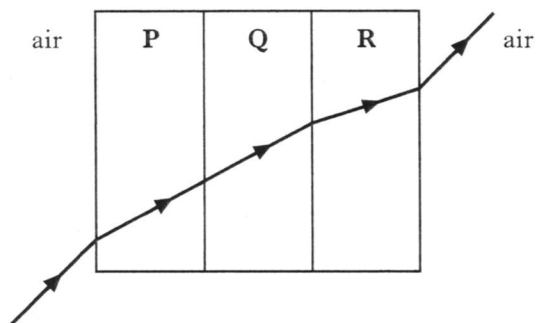

Which row in the table gives possible values for the refractive indices of the three plastics?

	<b>P</b>	<b>Q</b>	<b>R</b>
A	1.5	1.9	2.3
B	1.5	1.5	2.3
C	2.3	2.3	1.5
D	2.3	1.9	1.5
E	1.5	1.5	1.2

17. A unit for the intensity of light is

- A  $\text{J m}^{-1}$
- B  $\text{J m}^{-2}$
- C  $\text{J s}^{-1} \text{m}^{-1}$
- D  $\text{J s}^{-1} \text{m}^{-2}$
- E  $\text{J s}^{-2} \text{m}^{-2}$ .

18. When light of frequency  $f$  is shone on to a certain metal, photoelectrons are ejected with a maximum velocity  $v$  and kinetic energy  $E_k$ .

When light of the same frequency and twice the intensity is shone on the same surface then

- I twice as many electrons are ejected per second
- II the speed of the fastest electrons is now  $2v$
- III the kinetic energy of the fastest electrons is now  $2E_k$ .

Which of the statements above is/are correct?

- A I only
- B II only
- C III only
- D I and II only
- E II and III only

19. A student writes the following statements about n-type semiconductor material.

- I Most charge carriers are negative.
- II The n-type material has a negative charge.
- III Impurity atoms in the material have 5 outer electrons.

Which of these statements is/are true?

- A I only
- B II only
- C III only
- D I and II only
- E I and III only

20. Which of the following statements describes nuclear fission?

- A A nucleus of large mass number splits into two nuclei, releasing several neutrons.
- B A nucleus of large mass number splits into two nuclei, releasing several electrons.
- C A nucleus of large mass number splits into two nuclei, releasing several protons.
- D Two nuclei combine to form one nucleus, releasing several electrons.
- E Two nuclei combine to form one nucleus, releasing several neutrons.

**[SECTION B begins on *Page eleven*]**

SECTION B

Write your answers to questions 21 to 29 in the answer book.

Marks

21. A golfer on an elevated tee hits a golf ball with an initial velocity of  $35.0 \text{ m s}^{-1}$  at an angle of  $40^\circ$  to the horizontal.

The ball travels through the air and hits the ground at point R.

Point R is 12 m below the height of the tee, as shown.

diagram not to scale

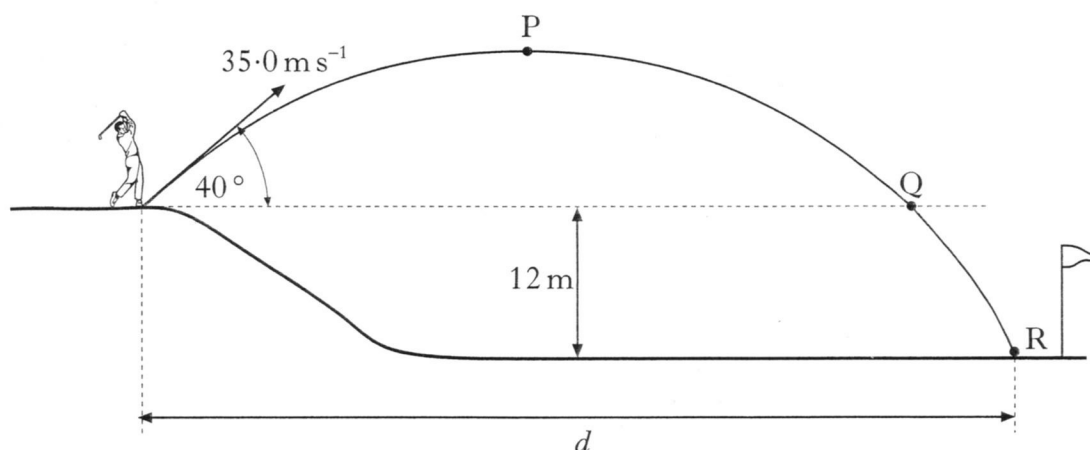

The effects of air resistance can be ignored.

(a) Calculate:

- (i) the horizontal component of the initial velocity of the ball;
- (ii) the vertical component of the initial velocity of the ball;
- (iii) the time taken for the ball to reach its maximum height at point P. 4

(b) From its maximum height at point P, the ball falls to point Q, which is at the same height as the tee.

It then takes a further 0.48 s to travel from Q until it hits the ground at R.

Calculate the total horizontal distance  $d$  travelled by the ball. 3

(7)

[Turn over

22. Two ice skaters are initially skating together, each with a velocity of  $2.2 \text{ m s}^{-1}$  to the right as shown.

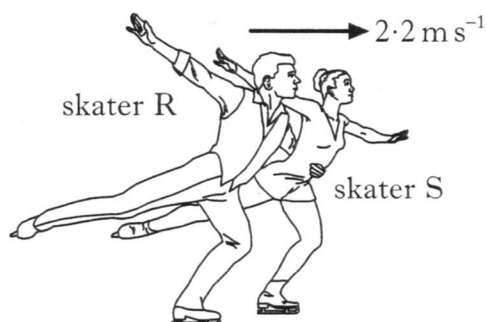

The mass of skater R is  $54 \text{ kg}$ . The mass of skater S is  $38 \text{ kg}$ .

Skater R now pushes skater S with an average force of  $130 \text{ N}$  for a short time. This force is in the same direction as their original velocity.

As a result, the velocity of skater S increases to  $4.6 \text{ m s}^{-1}$  to the right.

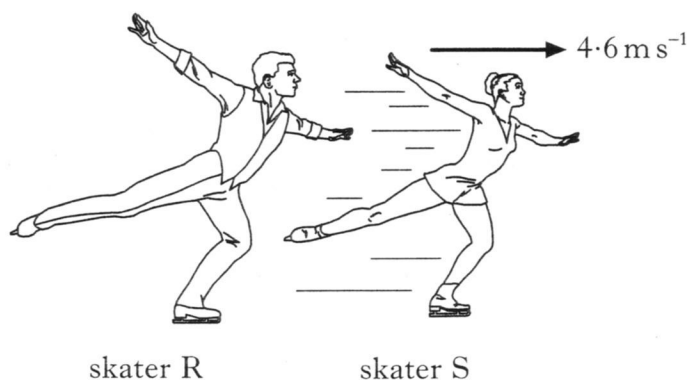

- (a) Calculate the magnitude of the change in momentum of skater S. 2
- (b) How long does skater R exert the force on skater S? 2
- (c) Calculate the velocity of skater R immediately after pushing skater S. 2
- (d) Is this interaction between the skaters elastic? 3  
 You must justify your answer by calculation. (9)



23. A tank of water rests on a smooth horizontal surface.

(a) A student takes measurements of the pressure at various depths below the surface of the water, using the apparatus shown.

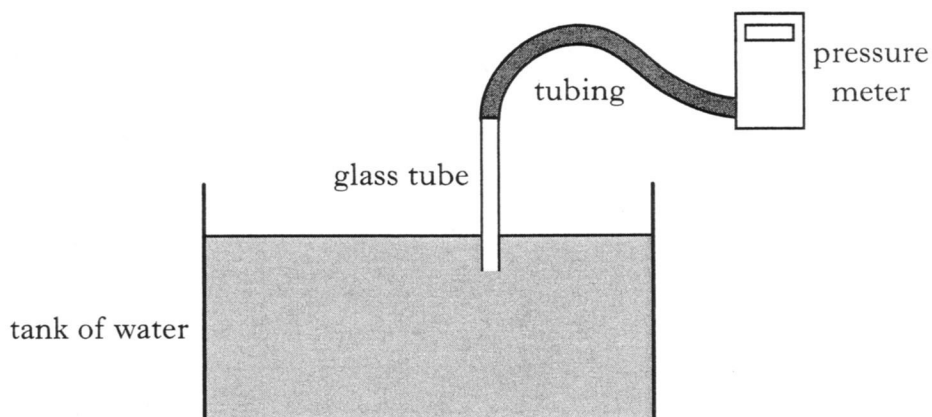

The pressure meter is set to zero before the glass tube is lowered into the water.

- (i) Sketch a graph to show how the pressure due to the water varies with depth below the surface of the water.
- (ii) Calculate the pressure due to the water at a depth of 0.25 m below its surface.
- (iii) As the glass tube is lowered further into the tank, the student notices that some water rises inside the glass tube. Explain why this happens.

4

(b) The mass of water in the tank is  $2.7 \times 10^3$  kg. The tank has a mass of 300 kg and a flat rectangular base. The dimensions of the tank are shown in the diagram below.

Atmospheric pressure is  $1.01 \times 10^5$  Pa.

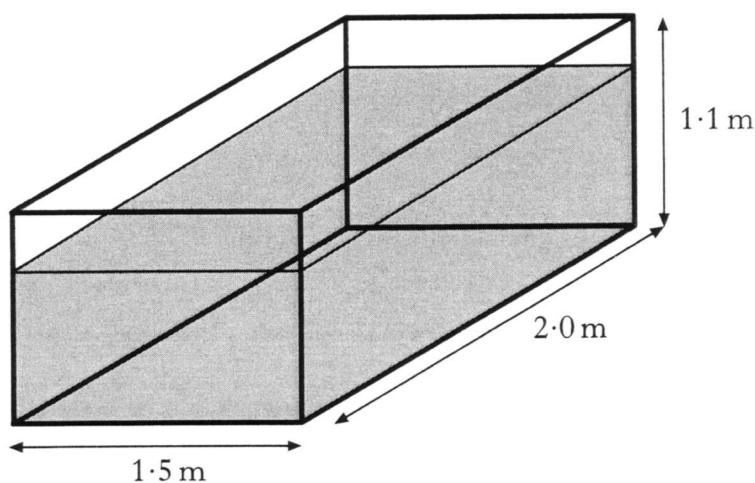

Calculate the total pressure exerted by the base of the tank on the surface on which it rests.

3  
(7)

24. A technician designs the following apparatus to investigate the pressure of a gas at different temperatures.

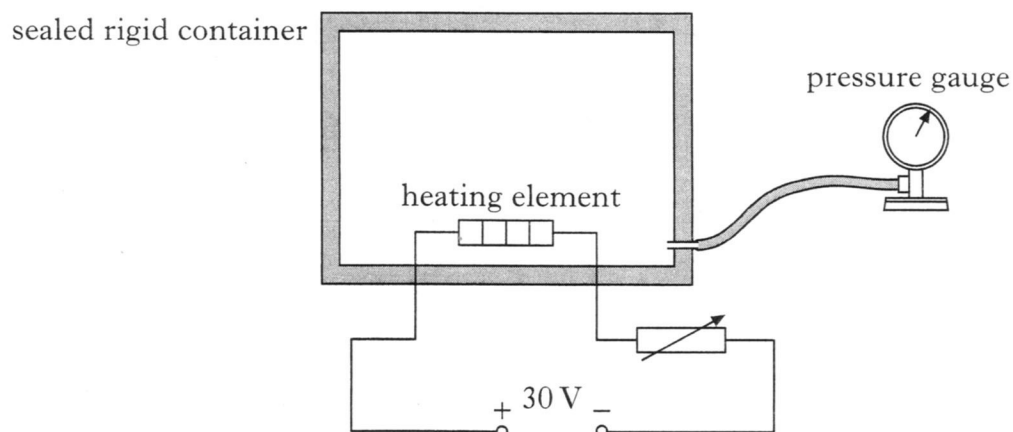

The heating element is used to raise the temperature of the gas.

- (a) Initially the gas is at a pressure of  $1.56 \times 10^5 \text{ Pa}$  and a temperature of  $27^\circ\text{C}$ . The temperature of the gas is then raised by  $50^\circ\text{C}$ .

Calculate the new pressure of the gas in the container.

2

- (b) The power supply shown above has an e.m.f. of  $30 \text{ V}$  and negligible internal resistance. The resistance of the heating element is  $0.50 \Omega$  and the resistance of the variable resistor is set to  $1.50 \Omega$ .

- (i) Calculate the power output from the heating element.
- (ii) How would your answer to part (b)(i) be affected if the internal resistance of the power supply was **not** negligible? You must justify your answer.

4

(6)

25. (a) A signal generator is connected to an oscilloscope. The output of the signal generator is set to a peak voltage of 15 V.

The following diagram shows the trace obtained, the Y-gain and the timebase controls on the oscilloscope. The scale for the Y-gain has been omitted.

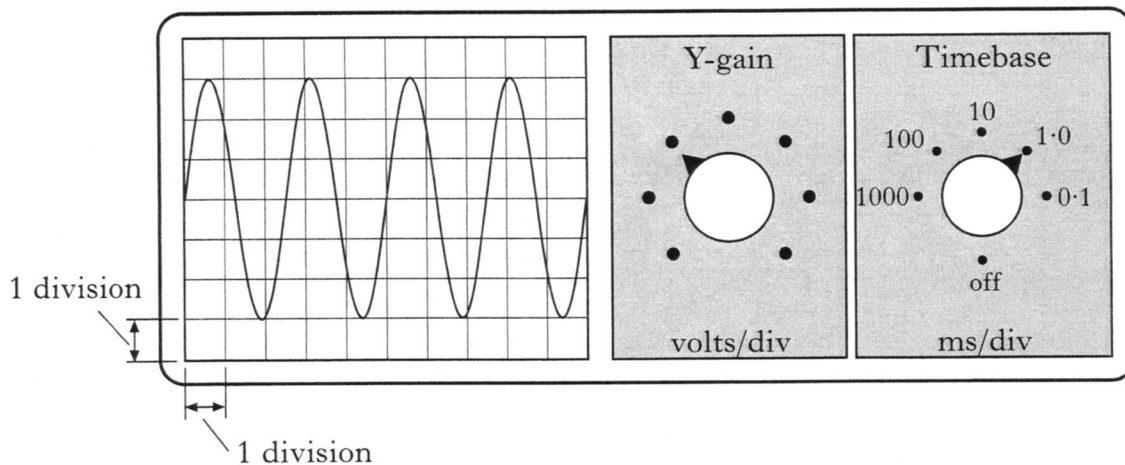

Calculate:

- (i) the Y-gain setting of the oscilloscope;
  - (ii) the frequency of the signal in hertz.
- (b) The signal generator is now connected in the circuit shown below.

3

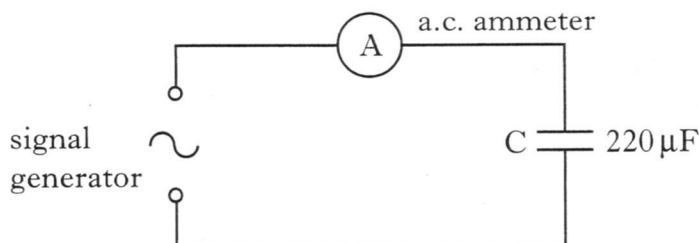

The signal generator is adjusted to give a peak output voltage of 12 V at a frequency of 300 Hz. The internal resistance of the signal generator and the resistance of the a.c. ammeter are negligible.

- (i) Calculate the r.m.s. value of the output voltage from the signal generator.
- (ii) Calculate the **maximum** energy stored by the capacitor during one cycle of the supply voltage.
- (iii) The frequency of the signal generator is gradually increased.  
What happens to the reading on the ammeter?
- (iv) When a capacitor is connected to a d.c. supply, the current quickly falls to zero. Explain why the current does **not** fall to zero in the circuit above.

6

(9)

[Turn over

26. A washing machine is filled with water, emptied and refilled several times during a wash cycle. A water level detector is used to ensure the water does not overflow.

One design of water level detector uses a specially shaped glass prism, as shown below.

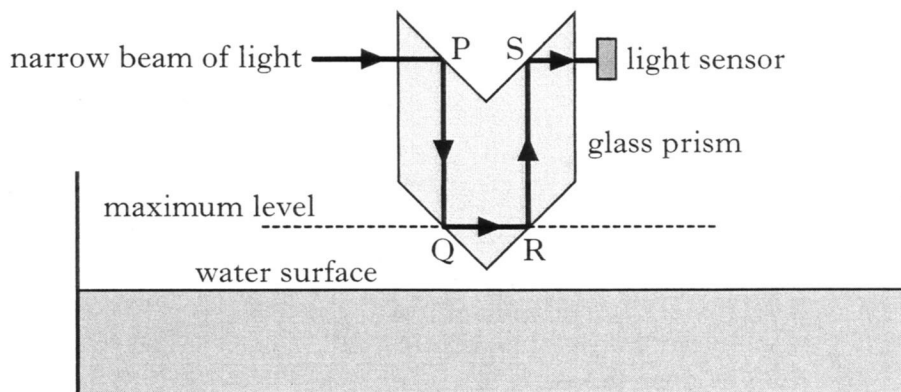

When the water in the machine is below the maximum level indicated in the diagram, the light sensor is illuminated by the narrow beam of light.

- (a) The light sensor consists of an LDR connected in a Wheatstone bridge circuit with values of resistance as shown.

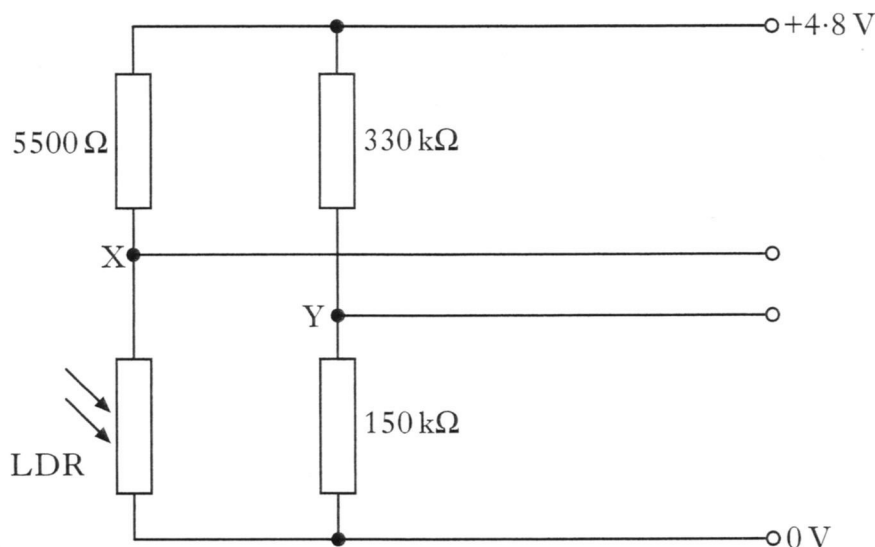

When the water in the machine is at the maximum level, the bridge is balanced.

Calculate the resistance of the LDR when the bridge is balanced.

2

26. (continued)

(b) Points X and Y of the Wheatstone bridge are connected to the inputs of an op-amp circuit as shown.

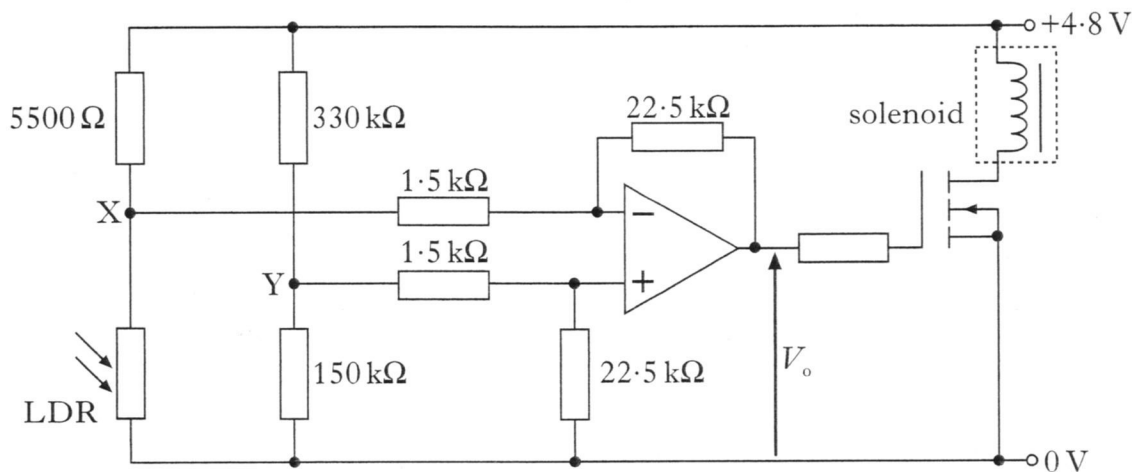

The potential at Y is 1.50 V. When the washing machine is filling with water, the narrow beam of light illuminates the LDR, the bridge is unbalanced and the potential at X is 1.28 V.

(i) Name the component in the circuit which has the following symbol.

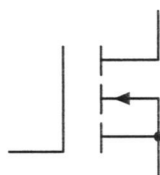

- (ii) Calculate the output voltage  $V_o$  of the op-amp when the LDR is illuminated.
- (iii) When there is a current in the solenoid, it holds a valve open and water flows into the washing machine.

When the water reaches the maximum level, the valve closes.

Explain how the circuit causes the valve to close when the water reaches the maximum level.

5

(c) When the water is at the maximum level, the narrow beam of light no longer illuminates the light sensor, because light leaves the prism at Q.

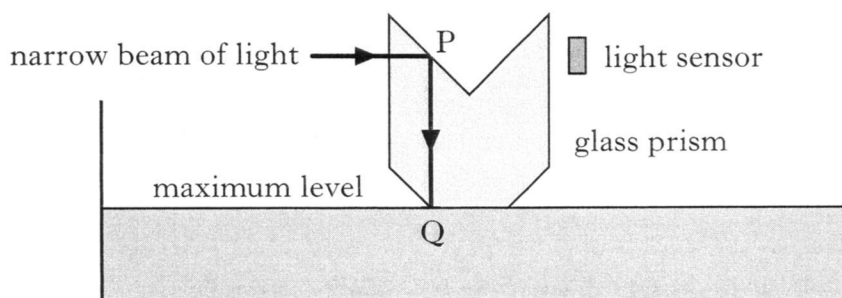

Explain why the light leaves the prism at Q.

1  
(8)

27. (a) Electrons which orbit the nucleus of an atom can be considered as occupying discrete energy levels.

The following diagram shows some of the energy levels for a particular atom.

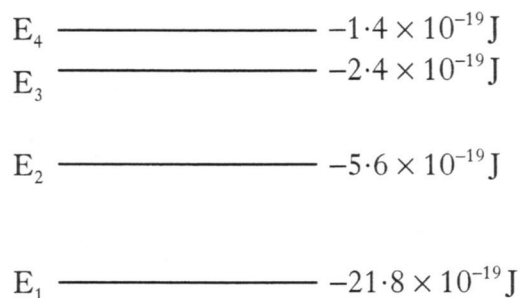

- (i) The transition between which two of these energy levels produces radiation with the longest wavelength? You must justify your answer.
- (ii) Calculate the frequency of the photon produced when an electron falls from  $E_3$  to  $E_2$ .
- (b) A laser produces light of frequency  $4.74 \times 10^{14} \text{ Hz}$  in air.

5

A ray of light from this laser is directed into a block of glass as shown below.

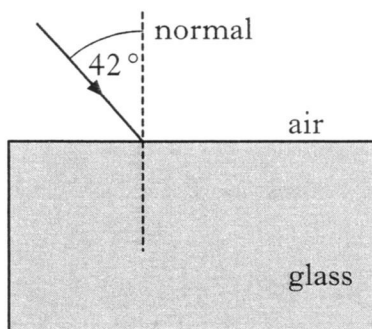

The refractive index of the glass for this light is 1.60.

- (i) What is the value of the frequency of the light in the block of glass?
- (ii) Calculate the wavelength of the light in the glass.

4

(9)

28. (a) An experiment with microwaves is set up as shown below.

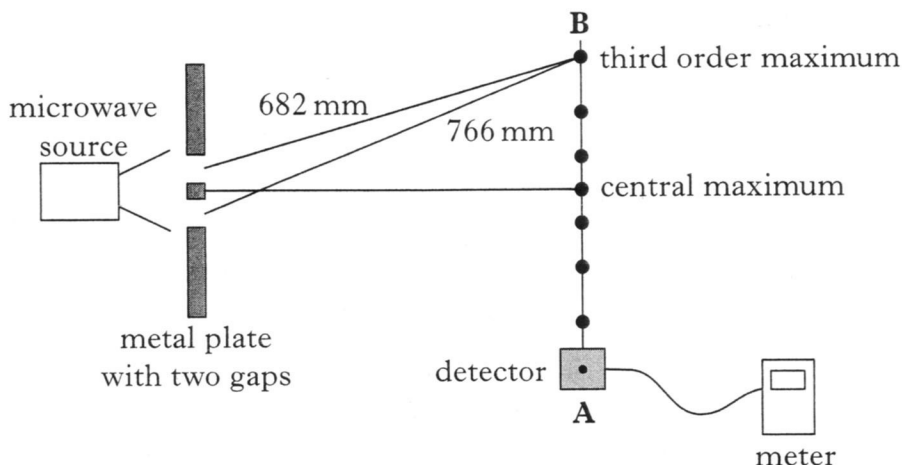

- (i) As the detector is moved from **A** to **B**, the reading on the meter increases and decreases several times.

Explain, in terms of waves, how the pattern of maxima and minima is produced.

- (ii) The measurements of the distance from each gap to a third order maximum are shown. Calculate the wavelength of the microwaves.

3

(b) A microphone is placed inside the cockpit of a jet aircraft.

The microphone is connected to the input terminals of the op-amp circuit shown below.

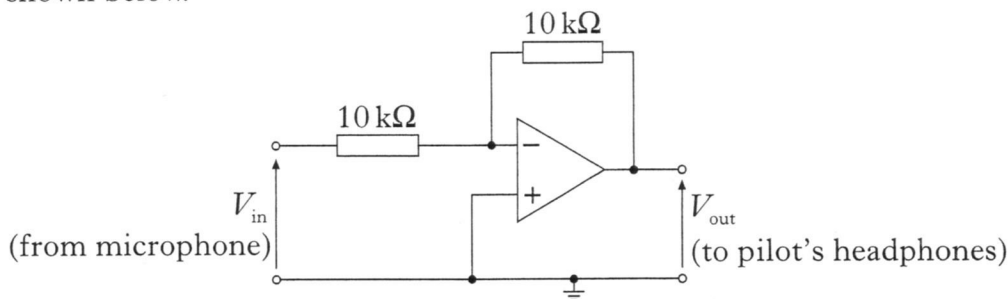

A noise in the cockpit produces the following signal from the microphone.

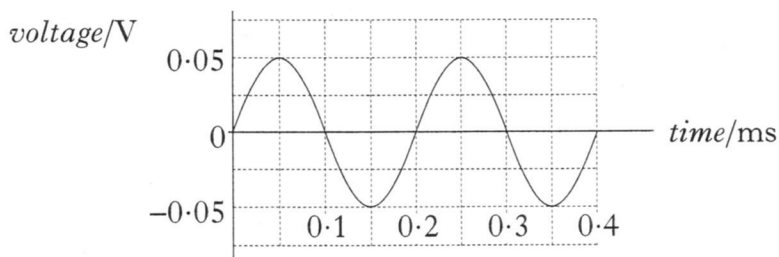

- (i) Sketch a graph of the corresponding output voltage  $V_{out}$  against time. Values are required on both axes.
- (ii) The output from the op-amp is connected to the pilot's headphones.

Explain why the sound produced by the headphones **reduces** the noise level heard by the pilot.

4

29. A technician is studying samples of radioactive substances.

- (a) The following statement describes a nuclear decay in one of the samples used by the technician.

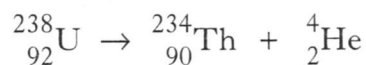

- (i) What type of particle is emitted during this decay?  
 (ii) In this sample  $7.2 \times 10^5$  nuclei decay in two minutes.

Calculate the average activity of the sample during this time.

3

- (b) The technician now studies the absorption of the radiation emitted from a different sample using the apparatus shown below.

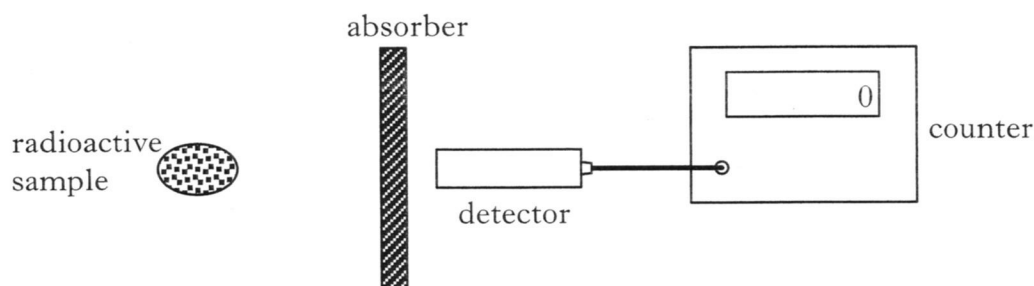

Different thicknesses of the absorber are placed in turn between the sample and the detector. For each thickness, the technician makes **repeated** measurements to obtain an average corrected count rate.

These results are then used to produce the following graph.



29. (b) (continued)

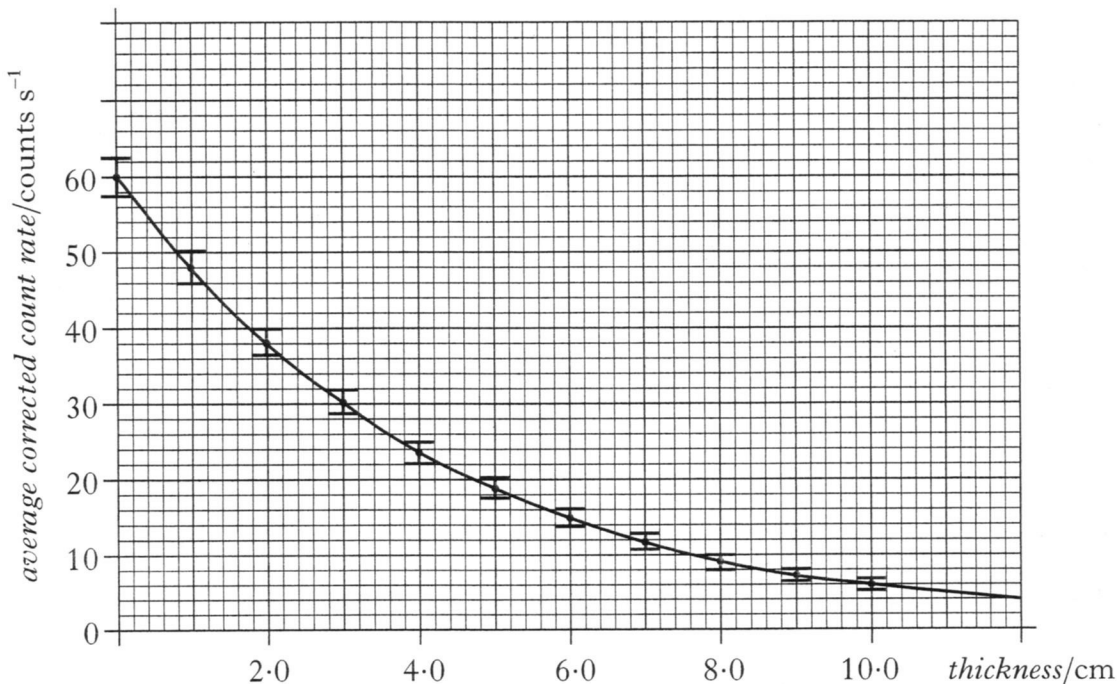

- (i) Use the graph to calculate the half-value thickness of the absorber material for this radiation.
- (ii) The technician has plotted each value of the average corrected count rate as a point with a vertical “bar” as shown.



Suggest a reason for this.

3

- (c) The technician receives a total dose equivalent of  $6.4 \times 10^{-5}$  Sv from these two sources.

The quality factor of the radiation used in part (a) is 20.

The absorbed dose received by the technician from the source used in part (b) is  $1.2 \times 10^{-5}$  Gy. The quality factor of this radiation is 1.

Calculate the absorbed dose received by the technician from the source used in part (a).

2

(8)

[END OF QUESTION PAPER]