

## X069/301

---

NATIONAL  
QUALIFICATIONS  
2001

MONDAY, 4 JUNE  
9.00 AM – 11.30 AM

PHYSICS  
HIGHER

### Read Carefully

- 1 All questions should be attempted.

### Section A (questions 1 to 20)

- 2 Check that the answer sheet is for Physics Higher (Section A).
- 3 Answer the questions numbered 1 to 20 on the answer sheet provided.
- 4 Fill in the details required on the answer sheet.
- 5 Rough working, if required, should be done only on this question paper, or on the first two pages of the answer book provided—**not** on the answer sheet.
- 6 For each of the questions 1 to 20 there is only **one** correct answer and each is worth 1 mark.
- 7 Instructions as to how to record your answers to questions 1–20 are given on page three.

### Section B (questions 21 to 29)

- 8 Answer questions numbered 21 to 29 in the answer book provided.
- 9 Fill in the details on the front of the answer book.
- 10 Enter the question number clearly in the margin of the answer book beside each of your answers to questions 21 to 29.
- 11 Care should be taken to give an appropriate number of significant figures in the final answers to calculations.

**DATA SHEET**

**COMMON PHYSICAL QUANTITIES**

<i>Quantity</i>	<i>Symbol</i>	<i>Value</i>	<i>Quantity</i>	<i>Symbol</i>	<i>Value</i>
Speed of light in vacuum	$c$	$3.00 \times 10^8 \text{ m s}^{-1}$	Mass of electron	$m_e$	$9.11 \times 10^{-31} \text{ kg}$
Magnitude of the charge on an electron	$e$	$1.60 \times 10^{-19} \text{ C}$	Mass of neutron	$m_n$	$1.675 \times 10^{-27} \text{ kg}$
Gravitational acceleration	$g$	$9.8 \text{ m s}^{-2}$	Mass of proton	$m_p$	$1.673 \times 10^{-27} \text{ kg}$
Planck's constant	$h$	$6.63 \times 10^{-34} \text{ J s}$			

**REFRACTIVE INDICES**

The refractive indices refer to sodium light of wavelength 589 nm and to substances at a temperature of 273 K.

<i>Substance</i>	<i>Refractive index</i>	<i>Substance</i>	<i>Refractive index</i>
Diamond	2.42	Water	1.33
Crown glass	1.50	Air	1.00

**SPECTRAL LINES**

<i>Element</i>	<i>Wavelength/nm</i>	<i>Colour</i>	<i>Element</i>	<i>Wavelength/nm</i>	<i>Colour</i>
Hydrogen	656	Red	Cadmium	644	Red
	486	Blue-green		509	Green
	434	Blue-violet		480	Blue
	410	Violet	<i>Lasers</i>		
	397	Ultraviolet	<i>Element</i>	<i>Wavelength/nm</i>	<i>Colour</i>
	389	Ultraviolet	Carbon dioxide	9550 } 10590 }	Infrared
Sodium	589	Yellow	Helium-neon	633	Red

**PROPERTIES OF SELECTED MATERIALS**

<i>Substance</i>	<i>Density/ kg m<sup>-3</sup></i>	<i>Melting Point/ K</i>	<i>Boiling Point/ K</i>
Aluminium	$2.70 \times 10^3$	933	2623
Copper	$8.96 \times 10^3$	1357	2853
Ice	$9.20 \times 10^2$	273	....
Sea Water	$1.02 \times 10^3$	264	377
Water	$1.00 \times 10^3$	273	373
Air	1.29	....	....
Hydrogen	$9.0 \times 10^{-2}$	14	20

The gas densities refer to a temperature of 273 K and a pressure of  $1.01 \times 10^5 \text{ Pa}$ .

SECTION A

For questions 1 to 20 in this section of the paper, an answer is recorded on the answer sheet by indicating the choice A, B, C, D or E by a stroke made in ink in the appropriate box of the answer sheet—see the example below.

EXAMPLE

The energy unit measured by the electricity meter in your home is the

- A ampere
- B kilowatt-hour
- C watt
- D coulomb
- E volt.

The correct answer to the question is B—kilowatt-hour. Record your answer by drawing a heavy vertical line joining the two dots in the appropriate box on your answer sheet in the column of boxes headed B. The entry on your answer sheet would now look like this:

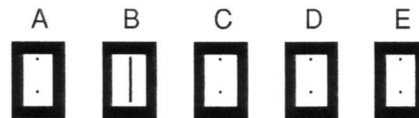

If after you have recorded your answer you decide that you have made an error and wish to make a change, you should cancel the original answer and put a vertical stroke in the box you now consider to be correct. Thus, if you want to change an answer D to an answer B, your answer sheet would look like this:

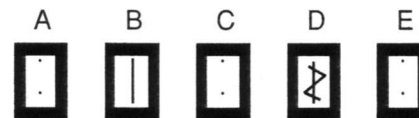

If you want to change back to an answer which has already been scored out, you should enter a tick (✓) to the RIGHT of the box of your choice, thus:



SECTION A

Answer questions 1–20 on the answer sheet.

1. Which one of the following pairs contains one vector quantity and one scalar quantity?

- A Force, kinetic energy
- B Power, speed
- C Displacement, acceleration
- D Work, potential energy
- E Momentum, velocity

2. The diagram below shows the resultant of two vectors.



Which of the diagrams below shows the vectors which could produce the above resultant?

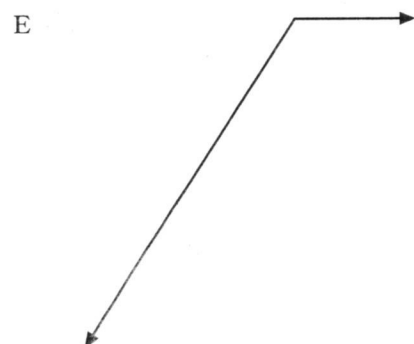
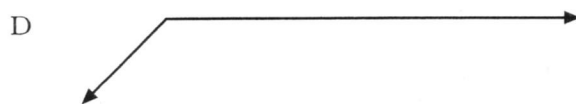
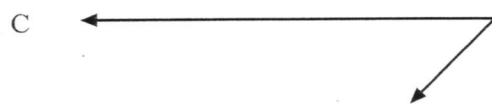
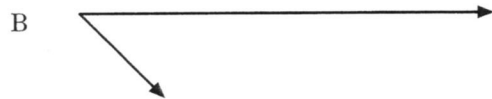
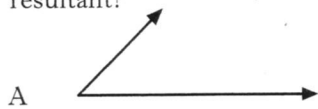

3. A helicopter is **descending** vertically at a constant speed of  $3.0 \text{ m s}^{-1}$ . A sandbag is released from the helicopter. The sandbag hits the ground  $5.0 \text{ s}$  later.

What was the height of the helicopter above the ground at the time the sandbag was released?

- A  $15.0 \text{ m}$
- B  $49.0 \text{ m}$
- C  $107.5 \text{ m}$
- D  $122.5 \text{ m}$
- E  $137.5 \text{ m}$

4. A car of mass  $900 \text{ kg}$  pulls a caravan of mass  $400 \text{ kg}$  along a straight, horizontal road with an acceleration of  $2.0 \text{ m s}^{-2}$ .

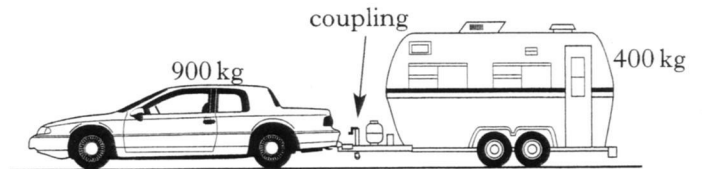

Assuming that the frictional forces on the caravan are negligible, the tension in the coupling between the car and the caravan is

- A  $400 \text{ N}$
- B  $500 \text{ N}$
- C  $800 \text{ N}$
- D  $1800 \text{ N}$
- E  $2600 \text{ N}$ .

5. A rocket of mass  $5.0 \text{ kg}$  is travelling horizontally with a speed of  $200 \text{ m s}^{-1}$  when it explodes into two parts. One part of mass  $3.0 \text{ kg}$  continues in the original direction with a speed of  $100 \text{ m s}^{-1}$ . The other part also continues in this same direction. Its speed is

- A  $150 \text{ m s}^{-1}$
- B  $200 \text{ m s}^{-1}$
- C  $300 \text{ m s}^{-1}$
- D  $350 \text{ m s}^{-1}$
- E  $700 \text{ m s}^{-1}$ .

6. A block floats in water and two other liquids X and Y at the levels shown.

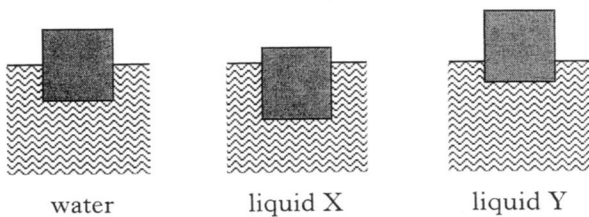

Which of the following statements is/are correct?

- I The density of the material of the block is less than the density of water.
- II The density of liquid X is less than the density of water.
- III The density of liquid X is greater than the density of liquid Y.

- A I only
- B II only
- C I and II only
- D I and III only
- E II and III only

7. Ice at  $-10^{\circ}\text{C}$  is heated until it becomes water at  $80^{\circ}\text{C}$ .

The temperature change on the kelvin scale is

- A 70 K
- B 90 K
- C 343 K
- D 363 K
- E 636 K.

8. In the diagrams below, each resistor has a resistance of  $1.0\ \text{ohm}$ .

Select the combination which has the **least** value of effective resistance between the terminals X and Y.

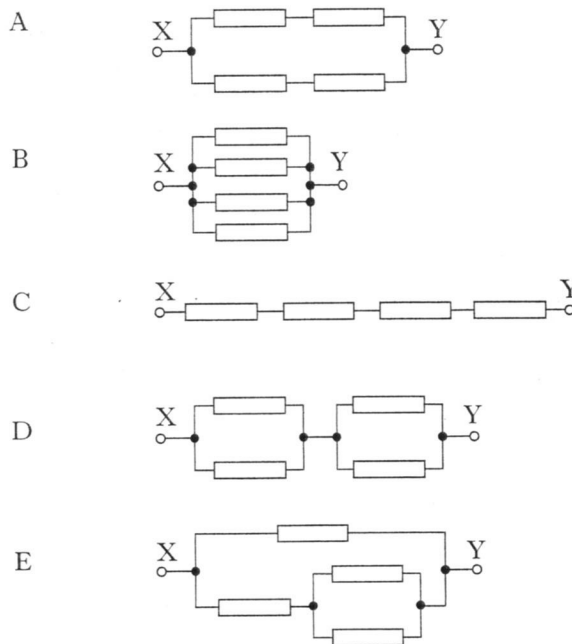

9. In the following circuit, the supply has negligible internal resistance.

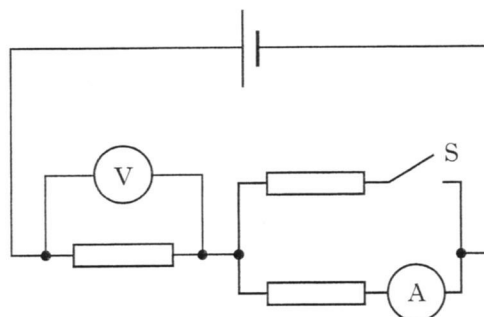

Switch S is now closed.

Which row in the table shows the effect on the ammeter and voltmeter readings?

	<i>Ammeter reading</i>	<i>Voltmeter reading</i>
A	increases	increases
B	increases	decreases
C	decreases	decreases
D	decreases	increases
E	decreases	remains the same

10. A supply with a sinusoidally alternating output of 6.0 V r.m.s. is connected to a 3.0 Ω resistor.

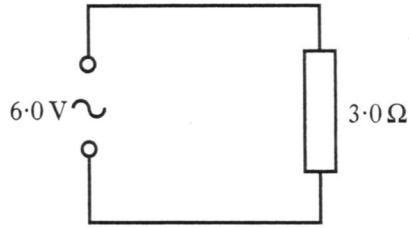

Which row in the following table shows the peak voltage across the resistor and the peak current in the circuit?

	Peak voltage/V	Peak current/A
A	$6\sqrt{2}$	$2\sqrt{2}$
B	$6\sqrt{2}$	2
C	6	2
D	$6\sqrt{2}$	$\frac{1}{2\sqrt{2}}$
E	6	$2\sqrt{2}$

11. A resistor and an ammeter are connected to a signal generator having an output of constant amplitude and variable frequency.

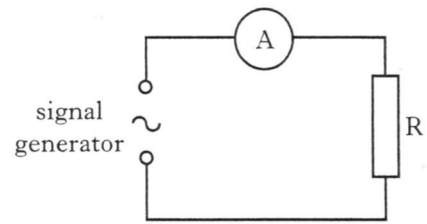

Which of the following graphs shows the correct relationship between the current  $I$  in the resistor and the output frequency  $f$  of the signal generator?

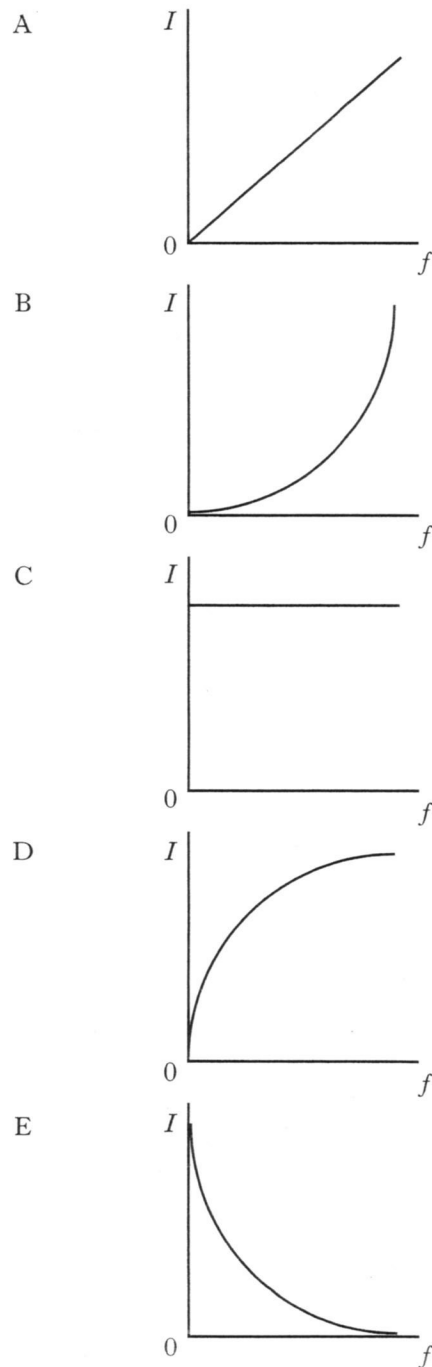

12. Which of the following statements is/are true for an ideal op-amp?

- I It has infinite input resistance.
- II Both input pins are at the same potential.
- III The input current to the op-amp is zero.

- A I only
- B II only
- C I and II only
- D II and III only
- E I, II and III

13. An op-amp circuit is shown in the diagram.

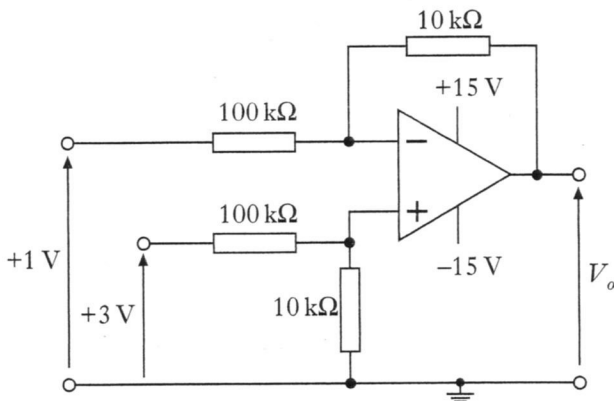

What is the output voltage  $V_o$ ?

- A -20 V
- B -2 V
- C -0.2 V
- D 0.2 V
- E 20 V

14. The energy of a water wave depends on its

- A speed
- B wavelength
- C frequency
- D period
- E amplitude.

15.  $S_1$  and  $S_2$  are sources of coherent waves which produce an interference pattern along the line XY.

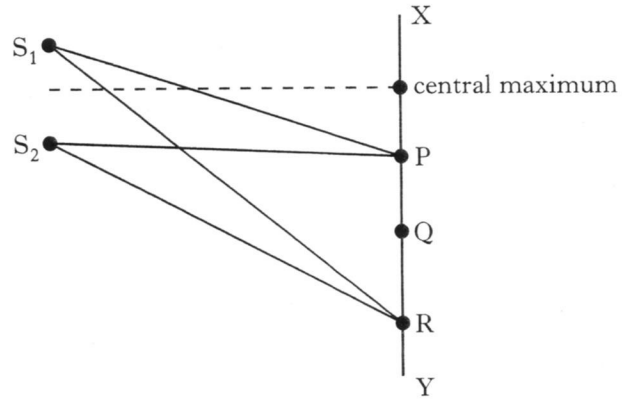

The first maximum occurs at P, where  $S_1P = 20$  cm and  $S_2P = 18$  cm.

For the third maximum, at R, the path difference ( $S_1R - S_2R$ ) is

- A 3 cm
- B 4 cm
- C 5 cm
- D 6 cm
- E 8 cm.

16. The spectrum of white light from a filament lamp may be viewed using a prism or a grating.

A student, asked to compare the spectra formed by the two methods, made the following statements.

- I The prism produces a spectrum by refraction. The grating produces a spectrum by interference.
- II The spectrum formed by the prism shows all the wavelengths present in the white light. The spectrum formed by the grating shows only a few specific wavelengths.
- III The prism produces a single spectrum. The grating produces more than one spectrum.

Which of the above statements is/are true?

- A I only
- B II only
- C I and II only
- D I and III only
- E I, II and III

17. Red light passes from air into water.

What happens to the speed and frequency of the light when it enters the water?

	<i>Speed</i>	<i>Frequency</i>
A	increases	increases
B	increases	stays constant
C	decreases	stays constant
D	decreases	decreases
E	stays constant	decreases

18. The intensity of light from a point source is  $20 \text{ W m}^{-2}$  at a distance of 5.0 m from the source.

What is the intensity of the light at a distance of 25 m from the source?

- A  $0.032 \text{ W m}^{-2}$   
 B  $0.80 \text{ W m}^{-2}$   
 C  $1.2 \text{ W m}^{-2}$   
 D  $4.0 \text{ W m}^{-2}$   
 E  $100 \text{ W m}^{-2}$

19. Ultraviolet radiation causes the emission of photoelectrons from a zinc plate.

The intensity of the ultraviolet radiation is increased. Which row in the following table shows the effect of this change?

	<i>Maximum kinetic energy of a photoelectron</i>	<i>Number of photoelectrons per second</i>
A	increases	no change
B	no change	increases
C	no change	no change
D	increases	increases
E	decreases	increases

20. Under certain conditions, a nucleus of nitrogen absorbs an alpha particle to form the nucleus of another element and releases a single particle.

Which one of the following statements correctly describes this process?

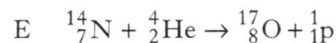
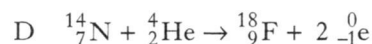
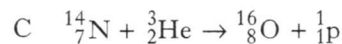
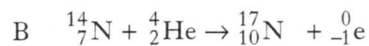
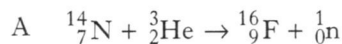



## SECTION B

Write your answers to questions 21 to 29 in the answer book.

Marks

21. (a) A box of mass 18 kg is at rest on a horizontal frictionless surface. A force of 4.0 N is applied to the box at an angle of  $26^\circ$  to the horizontal.

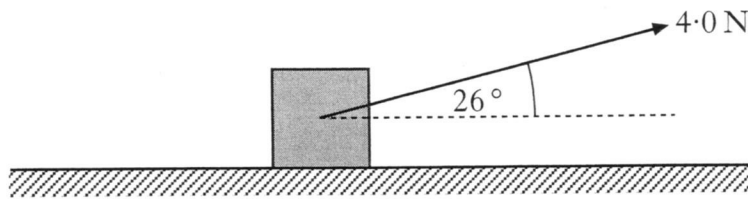

- (i) Show that the horizontal component of this force is 3.6 N.
  - (ii) Calculate the acceleration of the box along the horizontal surface.
  - (iii) Calculate the horizontal distance travelled by the box in a time of 7.0 s.
- (b) The box is replaced at rest at its starting position. The force of 4.0 N is now applied to the box at an angle of less than  $26^\circ$  to the horizontal.

5

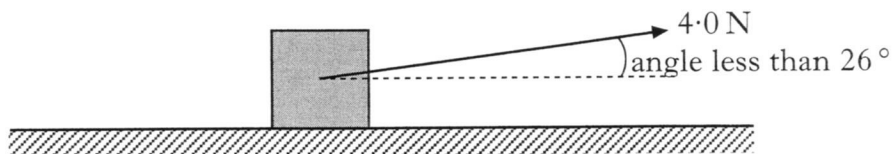

The force is applied for a time of 7.0 s as before.

How does the distance travelled by the box compare with your answer to part (a)(iii)?

You must justify your answer.

2

(7)

[Turn over

22. (a) In an experiment to find the density of air, a student first measures the mass of a flask full of air as shown below.

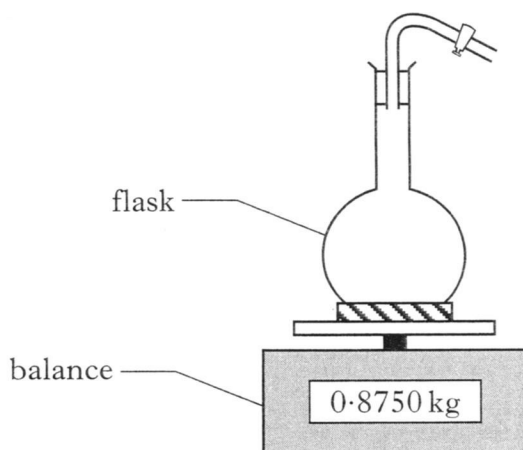

The air is now removed from the flask and the mass of the evacuated flask measured.

This procedure is repeated a number of times and the following table of measurements is obtained.

	<i>Experiment number</i>					
	1	2	3	4	5	6
<i>Mass of flask and air/kg</i>	0.8750	0.8762	0.8748	0.8755	0.8760	0.8757
<i>Mass of evacuated flask/kg</i>	0.8722	0.8736	0.8721	0.8728	0.8738	0.8732
<i>Mass of air removed/kg</i>						

The volume of the flask is measured as  $2.0 \times 10^{-3} \text{ m}^3$ .

- (i) Copy and complete the **bottom row** of the table.
- (ii) Calculate the mean mass of air removed from the flask **and** the random uncertainty in this mean. Express the mean mass and the random uncertainty in kilograms.
- (iii) Use these measurements to calculate the density of air.
- (iv) Another student carries out the same experiment using a flask of larger volume.

Explain why this is a better design for the experiment.

6

## 22. (continued)

- (b) The cylinder of a bicycle pump has a length of 360 mm as shown in the diagram.

The outlet of the pump is sealed.

The piston is pushed inwards until it is 160 mm from the outlet.

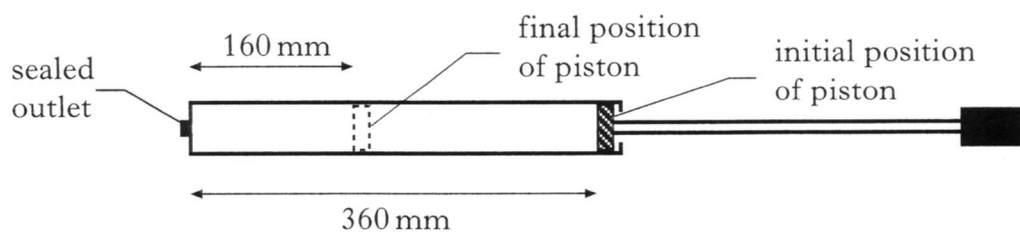

The initial pressure of the air in the pump is  $1.0 \times 10^5$  Pa.

- (i) Assuming that the temperature of the air trapped in the cylinder remains constant, calculate the final pressure of the trapped air.
- (ii) State one other assumption you have made for this calculation.
- (iii) Use the kinetic model to explain what happens to the pressure of the trapped air as its volume decreases.

5

(11)

[Turn over

23. Beads of liquid moving at high speed are used to move threads in modern weaving machines.

(a) In one design of machine, beads of water are accelerated by jets of air as shown in the diagram.

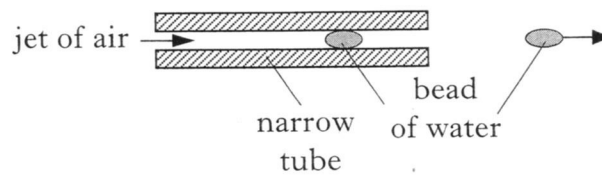

Each bead has a mass of  $2.5 \times 10^{-5}$  kg.

When designing the machine, it was estimated that each bead of water would start from rest and experience a constant unbalanced force of 0.5 N for a time of 3.0 ms.

(i) Calculate:

(A) the impulse on a bead of water;

(B) the speed of the bead as it emerges from the tube.

(ii) In practice the force on a bead varies.

The following graph shows how the actual unbalanced force exerted on each bead of water varies with time.

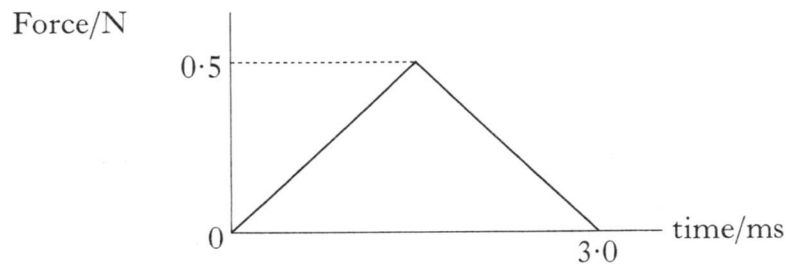

Use information from this graph to show that the bead leaves the tube with a speed equal to half of the value calculated in part (i)(B). 6

(b) Another design of machine uses beads of oil and two metal plates X and Y.

The potential difference between these plates is  $5.0 \times 10^3$  V.

Each bead of oil has a mass of  $4.0 \times 10^{-5}$  kg and is given a negative charge of  $6.5 \times 10^{-6}$  C.

The bead accelerates from rest at plate X and passes through a hole in plate Y.

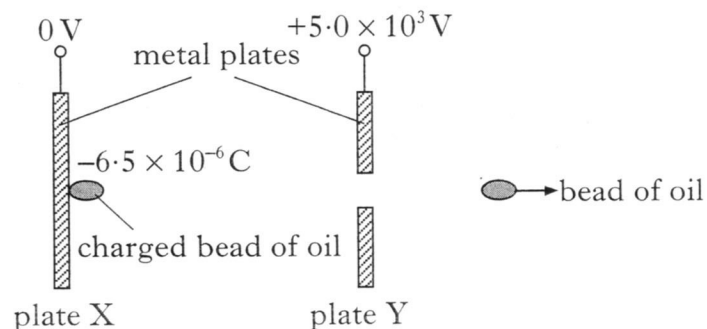

Neglecting air friction, calculate the speed of the bead at plate Y. 3

24. (a) The following circuit is used to measure the e.m.f. and the internal resistance of a battery.

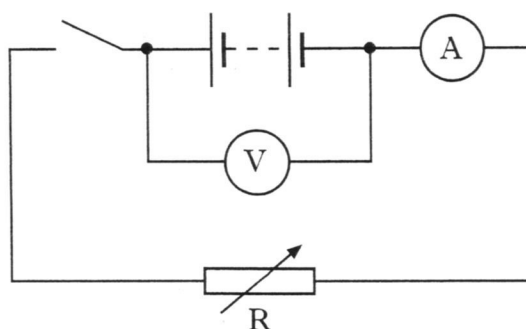

Readings of current and potential difference from this circuit are used to produce the following graph.

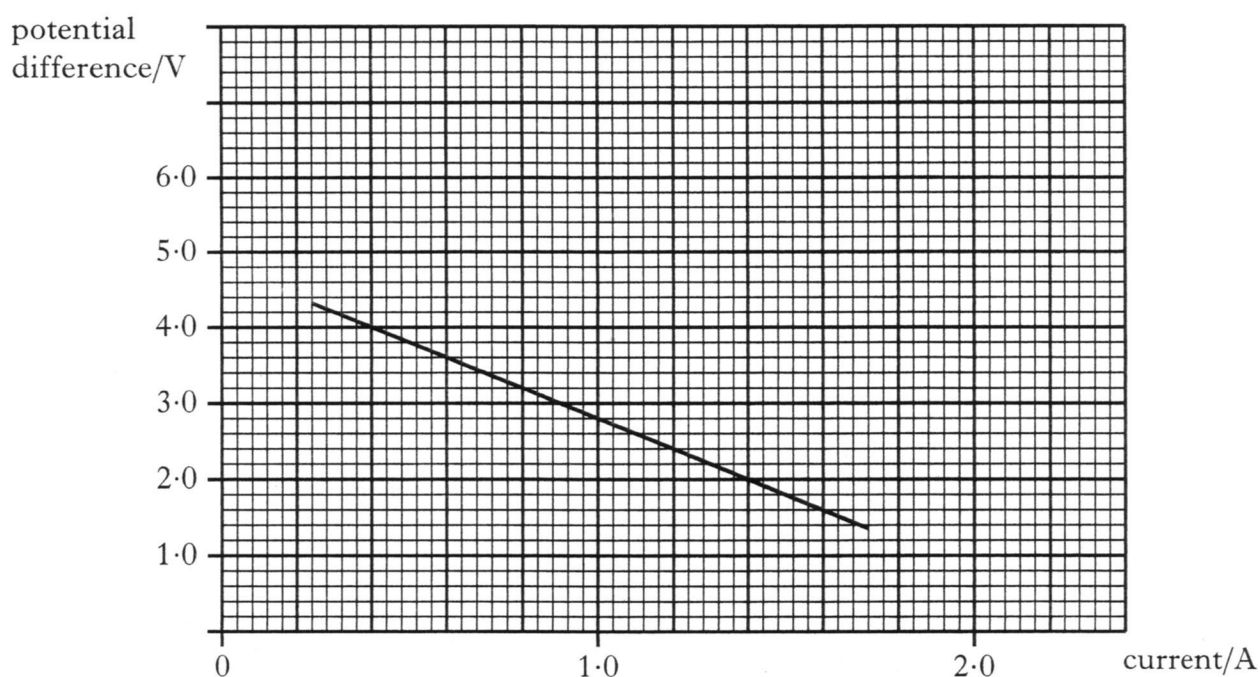

Use information from the graph to find:

- (i) the e.m.f. of the battery, in volts;
- (ii) the internal resistance of the battery.

3

- (b) A car battery has an e.m.f. of 12 V and an internal resistance of  $0.050 \Omega$ .

- (i) Calculate the short circuit current for this battery.
- (ii) The battery is now connected in series with a lamp. The resistance of the lamp is  $2.5 \Omega$ . Calculate the power dissipated in the lamp.

5

(8)

[Turn over

25. (a) The following diagram shows a circuit that is used to investigate the charging of a capacitor.

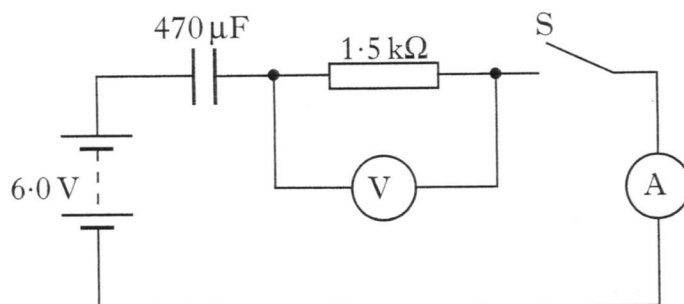

The capacitor is initially uncharged.

The capacitor has a capacitance of  $470\ \mu\text{F}$  and the resistor has a resistance of  $1.5\ \text{k}\Omega$ .

The battery has an e.m.f. of  $6.0\ \text{V}$  and negligible internal resistance.

- (i) Switch S is now closed. What is the initial current in the circuit?
  - (ii) How much energy is stored in the capacitor when it is fully charged?
  - (iii) What change could be made to this circuit to ensure that the **same** capacitor stores **more** energy?
- (b) A capacitor is used to provide the energy for an electronic flash in a camera.

When the flash is fired,  $6.35 \times 10^{-3}\ \text{J}$  of the stored energy is emitted as light.

The mean value of the frequency of photons of light from the flash is  $5.80 \times 10^{14}\ \text{Hz}$ .

Calculate the number of photons emitted in each flash of light.

5

3

(8)

26. (a) An op-amp is connected in a circuit as shown below.

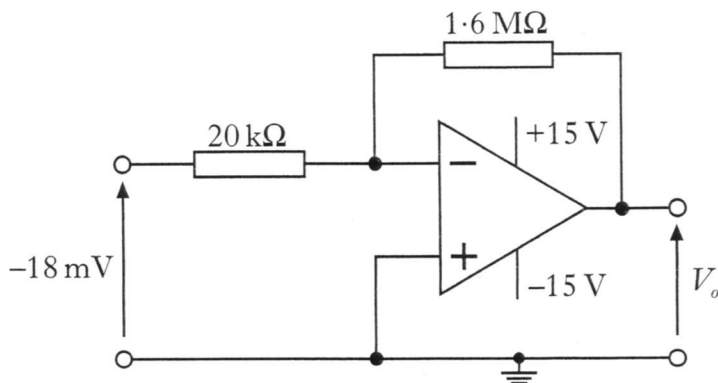

- (i) In which mode is the op-amp operating?
- (ii) A voltage of  $-18 \text{ mV}$  is connected to the input. Calculate the output voltage  $V_o$ .
- (iii) The supply voltage is now reduced from  $\pm 15 \text{ V}$  to  $\pm 12 \text{ V}$ .  
State any effect this change has on the output voltage. You must justify your answer.

4

(b) A student connects an op-amp as shown in the following diagram. An alternating voltage of peak value  $5.0 \text{ V}$  is connected to the input as shown.

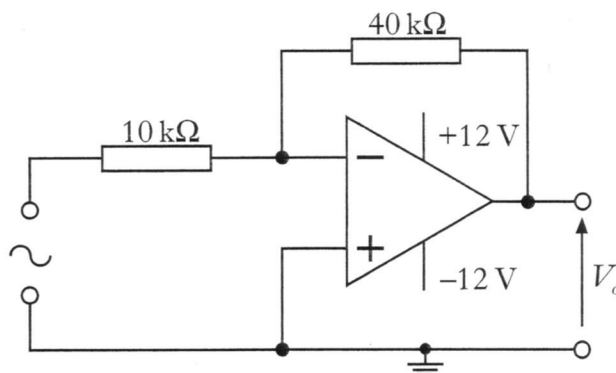
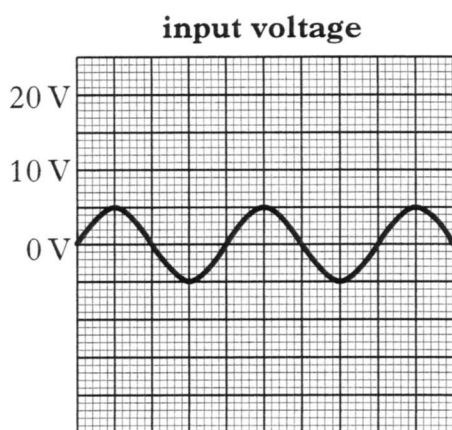

The sketch below shows the student's attempt to draw the corresponding output voltage.

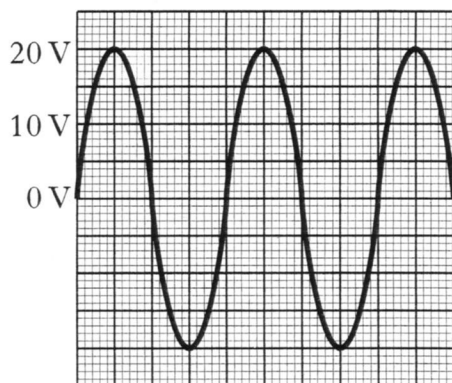

State the **two** mistakes in the student's sketch.

2

(6)

27. (a) Light of wavelength  $486 \times 10^{-9} \text{m}$  is viewed using a grating with a slit spacing of  $2.16 \times 10^{-6} \text{m}$ .

Calculate the angle between the central maximum and the second order maximum.

2

- (b) A ray of monochromatic light passes from air into a block of glass as shown.

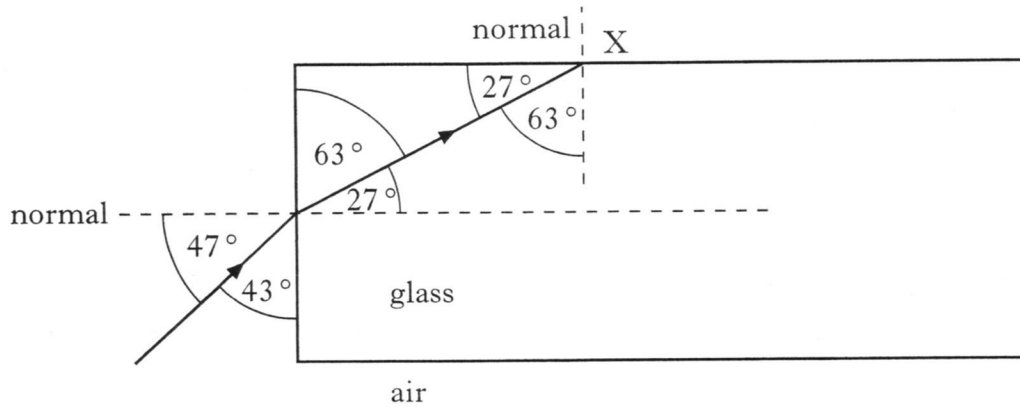

- (i) Using information from the diagram, show that the refractive index of the glass for this light is 1.61.
- (ii) Show by calculation whether the ray is totally internally reflected at point X.

4

(6)



28. (a) In a laser, the light is produced by stimulated emission of radiation.

Explain the term “stimulated emission” by making reference to the energy levels in atoms.

2

- (b) A laser beam is shone on to a screen which is marked with a grid.

The beam produces a uniformly lit spot of radius  $5.00 \times 10^{-4}$  m as shown.

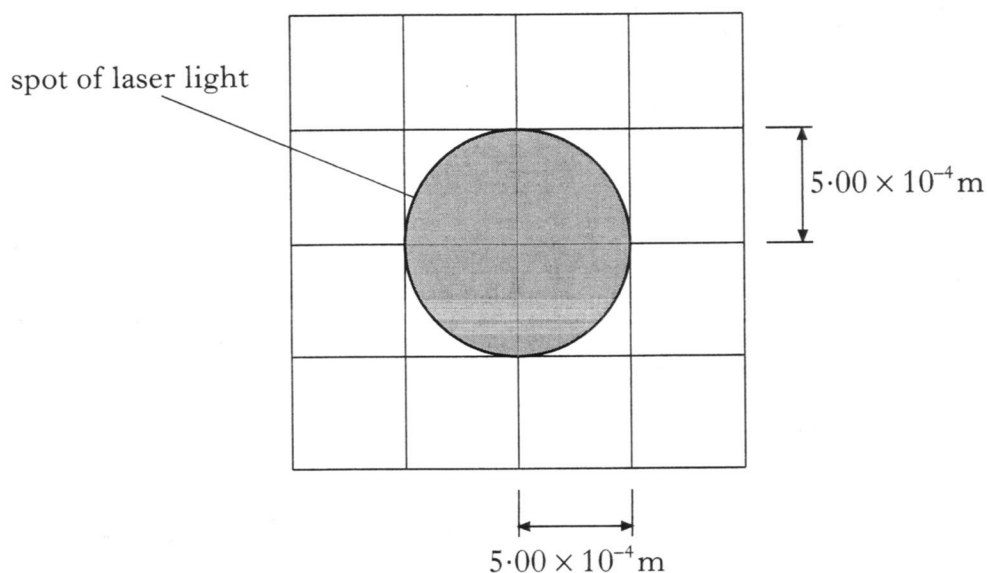

- (i) The intensity of the spot of light on the screen is  $1020 \text{ W m}^{-2}$ .  
Calculate the power of the laser beam.

- (ii) The distance between the screen and the laser is now doubled.

State how the radius of the spot now compares with the one shown in the diagram.

You must justify your answer.

5

(7)

[Turn over

29. (a) The following statement represents a nuclear reaction.

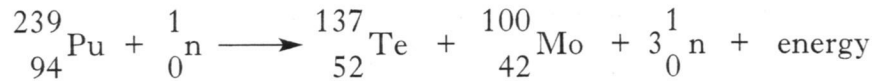

The total mass of the particles before the reaction is  $3.9842 \times 10^{-25}\text{kg}$  and the total mass of the particles after the reaction is  $3.9825 \times 10^{-25}\text{kg}$ .

- (i) State and explain whether this reaction is spontaneous or induced.
- (ii) Calculate the energy, in joules, released by this reaction.

3

- (b) A radioactive source is used to irradiate a sample of tissue of mass 0.50 kg.

The tissue absorbs  $9.6 \times 10^{-5}\text{J}$  of energy from the radiation emitted from the source.

The radiation has a quality factor of 1.

- (i) Calculate the absorbed dose received by the tissue.
- (ii) Calculate the dose equivalent received by the tissue.
- (iii) Placing a sheet of lead between the source and the tissue would have reduced the dose received by the tissue.

The half-value thickness of lead for this radiation is 40 mm.

Calculate the thickness of lead which would have limited the absorbed dose to one eighth of the value calculated in part (b)(i).

5

(8)

[END OF QUESTION PAPER]