

X069/301

NATIONAL
QUALIFICATIONS
2010

FRIDAY, 28 MAY
1.00 PM – 3.30 PM

PHYSICS
HIGHER

Read Carefully

Reference may be made to the Physics Data Booklet.

- 1 All questions should be attempted.

Section A (questions 1 to 20)

- 2 Check that the answer sheet is for Physics Higher (Section A).
- 3 For this section of the examination you must use an **HB pencil** and, where necessary, an eraser.
- 4 Check that the answer sheet you have been given has **your name, date of birth, SCN** (Scottish Candidate Number) and **Centre Name** printed on it.
Do not change any of these details.
- 5 If any of this information is wrong, tell the Invigilator immediately.
- 6 If this information is correct, **print** your name and seat number in the boxes provided.
- 7 There is **only one correct** answer to each question.
- 8 Any rough working should be done on the question paper or the rough working sheet, **not** on your answer sheet.
- 9 At the end of the exam, put the **answer sheet for Section A inside the front cover of your answer book.**
- 10 Instructions as to how to record your answers to questions 1–20 are given on page three.

Section B (questions 21 to 30)

- 11 Answer the questions numbered 21 to 30 in the answer book provided.
- 12 **All answers must be written clearly and legibly in ink.**
- 13 Fill in the details on the front of the answer book.
- 14 Enter the question number clearly in the margin of the answer book beside each of your answers to questions 21 to 30.
- 15 Care should be taken to give an appropriate number of significant figures in the final answers to calculations.
- 16 Where additional paper, eg square ruled paper, is used, write your name and SCN (Scottish Candidate Number) on it and place it inside the front cover of your answer booklet.



DATA SHEET
COMMON PHYSICAL QUANTITIES

<i>Quantity</i>	<i>Symbol</i>	<i>Value</i>	<i>Quantity</i>	<i>Symbol</i>	<i>Value</i>
Speed of light in vacuum	c	$3.00 \times 10^8 \text{ m s}^{-1}$	Mass of electron	m_e	$9.11 \times 10^{-31} \text{ kg}$
Magnitude of the charge on an electron	e	$1.60 \times 10^{-19} \text{ C}$	Mass of neutron	m_n	$1.675 \times 10^{-27} \text{ kg}$
Gravitational acceleration on Earth	g	9.8 m s^{-2}	Mass of proton	m_p	$1.673 \times 10^{-27} \text{ kg}$
Planck's constant	h	$6.63 \times 10^{-34} \text{ J s}$			

REFRACTIVE INDICES

The refractive indices refer to sodium light of wavelength 589 nm and to substances at a temperature of 273 K.

<i>Substance</i>	<i>Refractive index</i>	<i>Substance</i>	<i>Refractive index</i>
Diamond	2.42	Water	1.33
Crown glass	1.50	Air	1.00

SPECTRAL LINES

<i>Element</i>	<i>Wavelength/nm</i>	<i>Colour</i>	<i>Element</i>	<i>Wavelength/nm</i>	<i>Colour</i>
Hydrogen	656	Red	Cadmium	644	Red
	486	Blue-green		509	Green
	434	Blue-violet		480	Blue
	410	Violet	<i>Lasers</i>		
	397	Ultraviolet	<i>Element</i>	<i>Wavelength/nm</i>	<i>Colour</i>
	389	Ultraviolet	Carbon dioxide	9550 } 10590 }	Infrared
Sodium	589	Yellow	Helium-neon	633	Red

PROPERTIES OF SELECTED MATERIALS

<i>Substance</i>	<i>Density/ kg m⁻³</i>	<i>Melting Point/ K</i>	<i>Boiling Point/ K</i>
Aluminium	2.70×10^3	933	2623
Copper	8.96×10^3	1357	2853
Ice	9.20×10^2	273	...
Sea Water	1.02×10^3	264	377
Water	1.00×10^3	273	373
Air	1.29
Hydrogen	9.0×10^{-2}	14	20

The gas densities refer to a temperature of 273 K and a pressure of $1.01 \times 10^5 \text{ Pa}$.

SECTION A

For questions 1 to 20 in this section of the paper the answer to each question is either A, B, C, D or E. Decide what your answer is, then, using your pencil, put a horizontal line in the space provided—see the example below.

EXAMPLE

The energy unit measured by the electricity meter in your home is the

- A kilowatt-hour
- B ampere
- C watt
- D coulomb
- E volt.

The correct answer is **A**—kilowatt-hour. The answer **A** has been clearly marked in **pencil** with a horizontal line (see below).

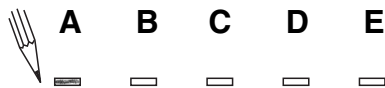

Changing an answer

If you decide to change your answer, carefully erase your first answer and, using your pencil, fill in the answer you want. The answer below has been changed to **E**.

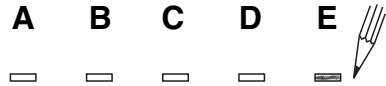

[Turn over

SECTION A

Answer questions 1–20 on the answer sheet.

1. Acceleration is the change in

- A distance per unit time
- B displacement per unit time
- C velocity per unit distance
- D speed per unit time
- E velocity per unit time.

2. The graph shows how the acceleration, a , of an object varies with time, t .

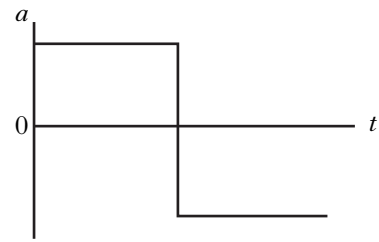

Which graph shows how the velocity, v , of the object varies with time, t ?

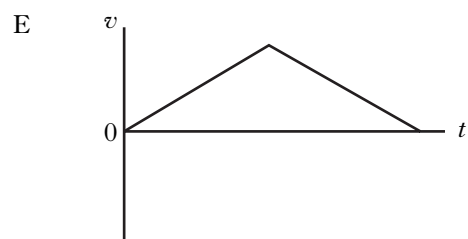
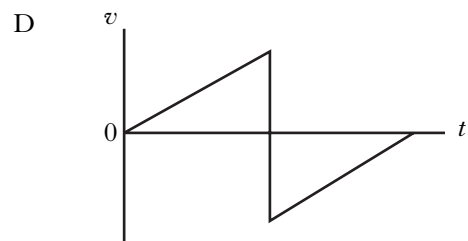
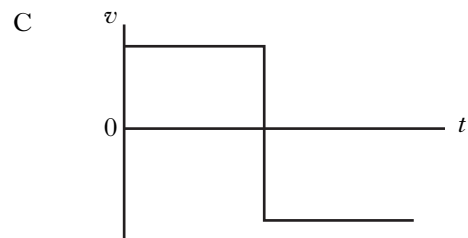
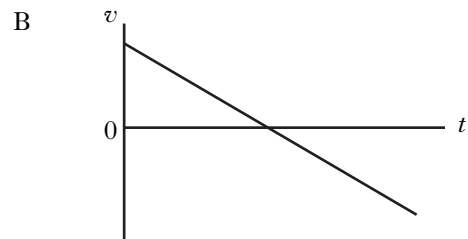
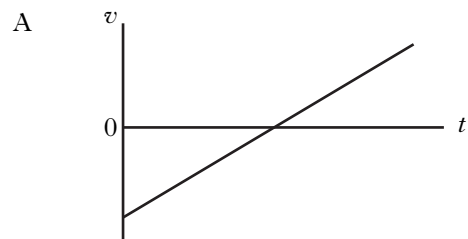

3. A car of mass 1000 kg is travelling at a speed of 40 m s^{-1} along a race track. The brakes are applied and the speed of the car decreases to 10 m s^{-1} .

How much kinetic energy is lost by the car?

- A 15 kJ
 B 50 kJ
 C 450 kJ
 D 750 kJ
 E 800 kJ
4. A substance can exist as a solid, a liquid or a gas.

Which row in the table shows the approximate relative magnitudes of the densities of the substance in these states?

	<i>Density of solid</i>	<i>Density of liquid</i>	<i>Density of gas</i>
A	1000	1000	1
B	10	10	1000
C	1	1	1000
D	1000	10	1
E	1	1	10

5. A fish is swimming at a depth of 10.4 m .
 The density of the water is $1.03 \times 10^3 \text{ kg m}^{-3}$.
 The pressure at this depth caused by the water is

- A $0.99 \times 10^2 \text{ Pa}$
 B $1.04 \times 10^4 \text{ Pa}$
 C $1.07 \times 10^4 \text{ Pa}$
 D $1.05 \times 10^5 \text{ Pa}$
 E $1.07 \times 10^5 \text{ Pa}$.

6. Ice at a temperature of -10°C is heated until it becomes water at 80°C .

The temperature change in kelvin is

- A 70 K
 B 90 K
 C 343 K
 D 363 K
 E 636 K.

7. The potential difference between two points is

- A the work done in moving one electron between the two points
 B the voltage between the two points when there is a current of one ampere
 C the work done in moving one coulomb of charge between the two points
 D the kinetic energy gained by an electron as it moves between the two points
 E the work done in moving any charge between the two points.

8. The product, X, of a nuclear reaction passes through an electric field as shown.

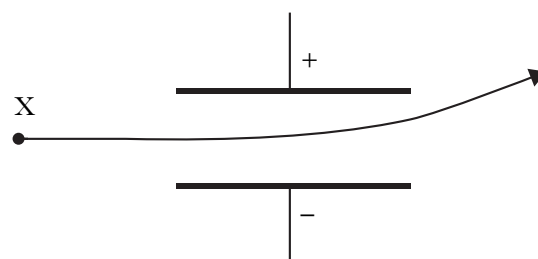

Product X is

- A an alpha particle
 B a beta particle
 C gamma radiation
 D a fast neutron
 E a slow neutron.

[Turn over

9. Which of the following combinations of resistors has the greatest resistance between X and Y?

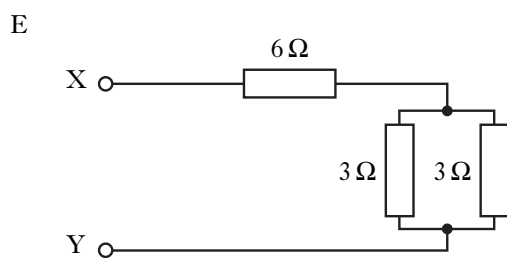
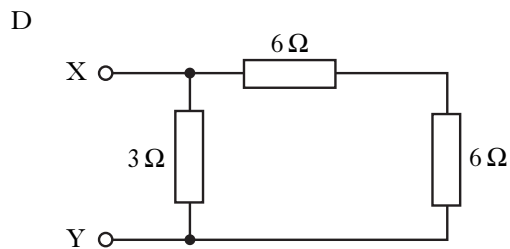
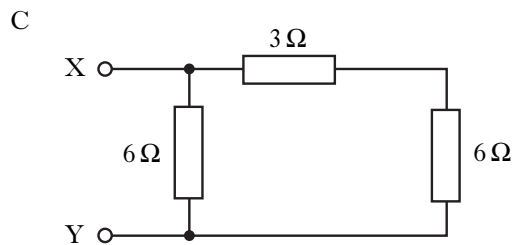
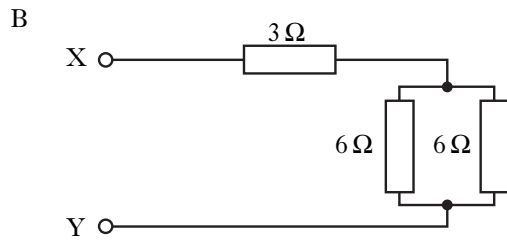
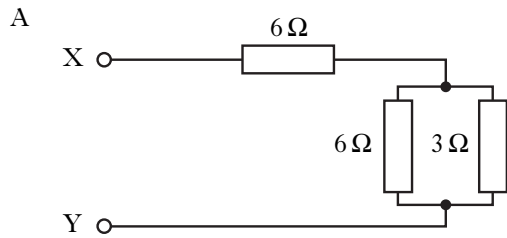

10. In the following Wheatstone bridge circuit, the reading on the voltmeter is zero when the resistance of R is set at $1\ \text{k}\Omega$.

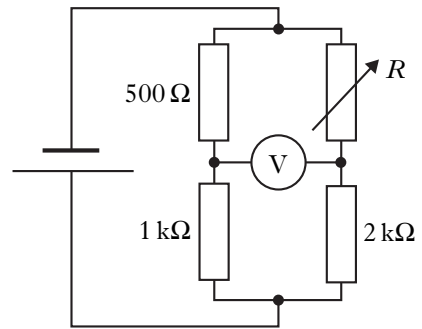

Which of the following is the graph of the voltmeter reading V against the resistance R ?

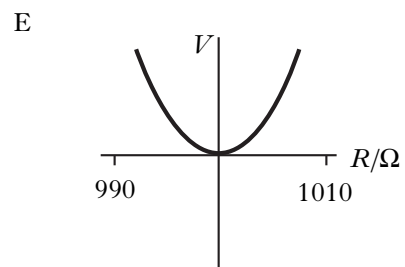
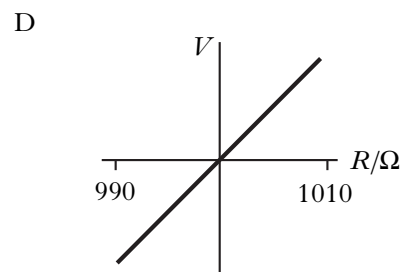
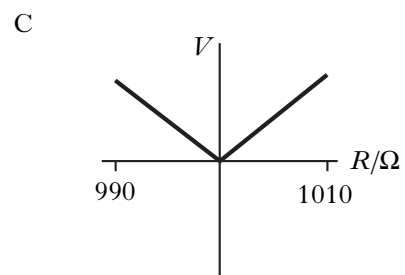
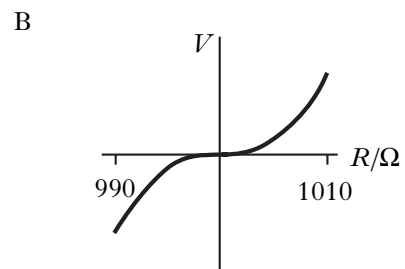
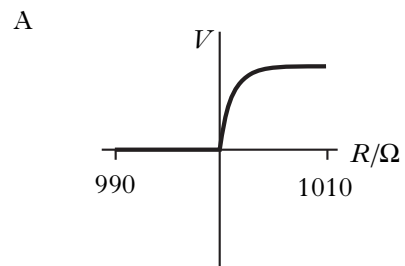

11. A student makes the following statements about capacitors.

- I Capacitors block a.c. signals.
- II Capacitors store energy.
- III Capacitors store charge.

Which of these statements is/are true?

- A I only
- B I and II only
- C I and III only
- D II and III only
- E I, II and III

12. A circuit is set up as shown.

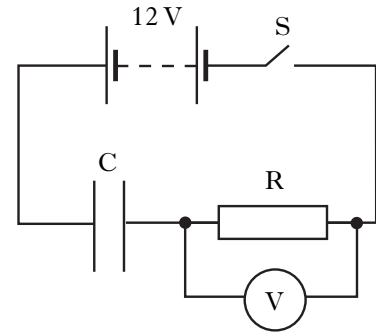

The capacitor is initially uncharged. Switch S is now closed. Which graph shows how the potential difference, V , across R, varies with time, t ?

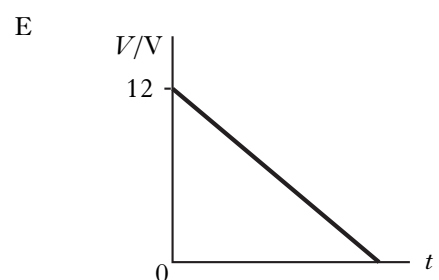
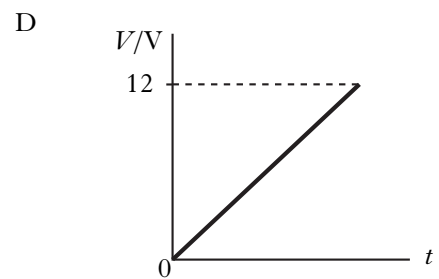
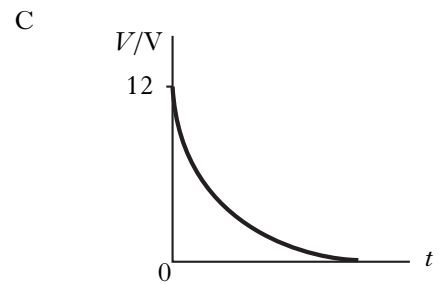
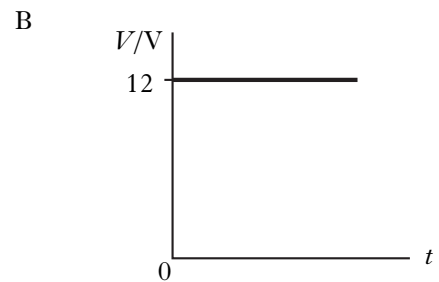
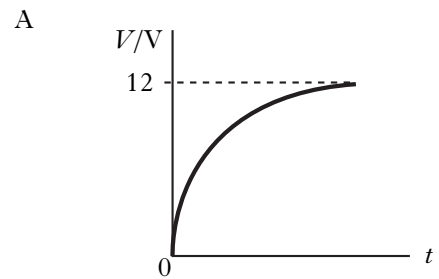

13. An op-amp is connected in a circuit as shown.

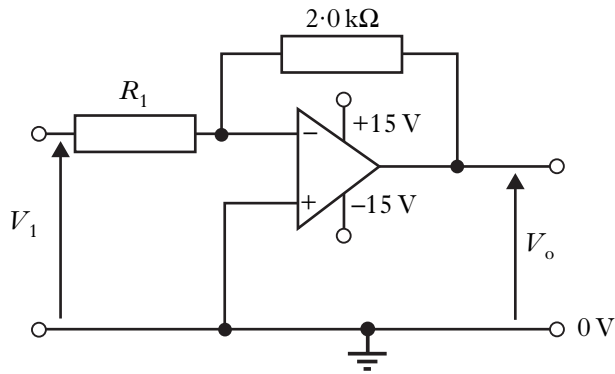

The input voltage V_1 is 0.50 V.

Which row in the table shows possible values for R_1 and V_o ?

	$R_1/\text{k}\Omega$	V_o/V
A	1.0	1.0
B	4.0	1.0
C	1.0	-0.25
D	4.0	-1.0
E	1.0	-1.0

14. Photons of energy 7.0×10^{-19} J are incident on a clean metal surface. The work function of the metal is 9.0×10^{-19} J.

Which of the following is correct?

- A No electrons are emitted from the metal.
- B Electrons with a maximum kinetic energy of 2.0×10^{-19} J are emitted from the metal.
- C Electrons with a maximum kinetic energy of 7.0×10^{-19} J are emitted from the metal.
- D Electrons with a maximum kinetic energy of 9.0×10^{-19} J are emitted from the metal.
- E Electrons with a maximum kinetic energy of 16×10^{-19} J are emitted from the metal.

15. The diagram represents some of the energy levels for an atom of a gas.

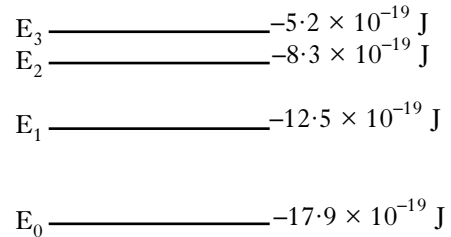

White light passes through the gas and absorption lines are observed in the spectrum.

Which electron transition produces the absorption line corresponding to the lowest frequency?

- A E_3 to E_2
- B E_2 to E_3
- C E_1 to E_0
- D E_0 to E_1
- E E_0 to E_3

16. An LED is connected as shown.

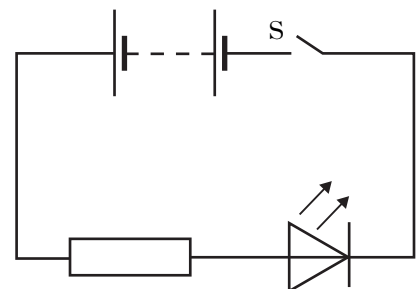

When switch S is closed

- A the p-n junction is reverse biased and free charge carriers are produced which may recombine to give quanta of radiation
- B the p-n junction is forward biased and positive and negative charge carriers are produced by the action of light
- C the p-n junction is reverse biased and positive and negative charge carriers are produced by the action of light
- D the p-n junction is forward biased and positive and negative charge carriers may recombine to give quanta of radiation
- E the p-n junction is reverse biased and positive and negative charge carriers may recombine to give quanta of radiation.

17. The diagram represents the structure of an n-channel enhancement MOSFET.

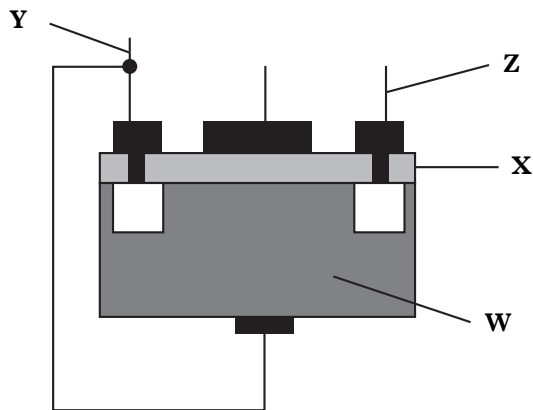

Which row in the table gives the names for the parts labelled W, X, Y and Z?

	W	X	Y	Z
A	substrate	implant	source	drain
B	implant	substrate	source	drain
C	substrate	oxide layer	drain	source
D	implant	substrate	gate	source
E	substrate	oxide layer	source	drain

18. The following statement describes a fusion reaction.

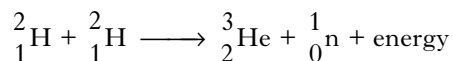

The total mass of the particles before the reaction is 6.684×10^{-27} kg.

The total mass of the particles after the reaction is 6.680×10^{-27} kg.

The energy released in this reaction is

- A 6.012×10^{-10} J
- B 6.016×10^{-10} J
- C 1.800×10^{-13} J
- D 3.600×10^{-13} J
- E 1.200×10^{-21} J.

19. A sample of tissue receives an equivalent dose of 40 mSv from a beam of neutrons.

The neutrons have a radiation weighting factor of 10.

The energy absorbed by the tissue is 100 μ J.

The mass of the tissue is

- A 2.5×10^{-4} kg
- B 2.5×10^{-2} kg
- C 4.0 kg
- D 40 kg
- E 4.0×10^3 kg.

20. A sample of tissue is placed near a source of gamma radiation. The equivalent dose rate for the tissue is $80 \mu\text{Sv h}^{-1}$.

The equivalent dose rate is now reduced to $10 \mu\text{Sv h}^{-1}$ by placing lead shielding between the source and the tissue.

The half value thickness of lead is 8.0 mm for this source.

The thickness of the lead shielding is

- A 1.0 mm
- B 8.0 mm
- C 24 mm
- D 64 mm
- E 80 mm.

[Turn over

SECTION B

Write your answers to questions 21 to 30 in the answer book.

21. A helicopter is flying at a constant height above the ground. The helicopter is carrying a crate suspended from a cable as shown.



- (a) The helicopter flies 20 km on a bearing of 180 (due South). It then turns on to a bearing of 140 (50° South of East) and travels a further 30 km.

The helicopter takes 15 minutes to travel the 50 km.

- (i) By scale drawing (or otherwise) find the resultant displacement of the helicopter. 2
- (ii) Calculate the average velocity of the helicopter during the 15 minutes. 2
- (b) The helicopter reaches its destination and hovers above a drop zone.
- (i) The total mass of the helicopter and crate is 1.21×10^4 kg.
Show that the helicopter produces a lift force of 119 kN. 1
- (ii) The helicopter now drops the crate which has a mass of 2.30×10^3 kg.
The lift force remains constant.
Describe the vertical motion of the helicopter immediately after the crate is dropped.
Justify your answer in terms of the forces acting on the helicopter. 2

(7)

22. The apparatus shown is set up to investigate collisions between two vehicles on a track.

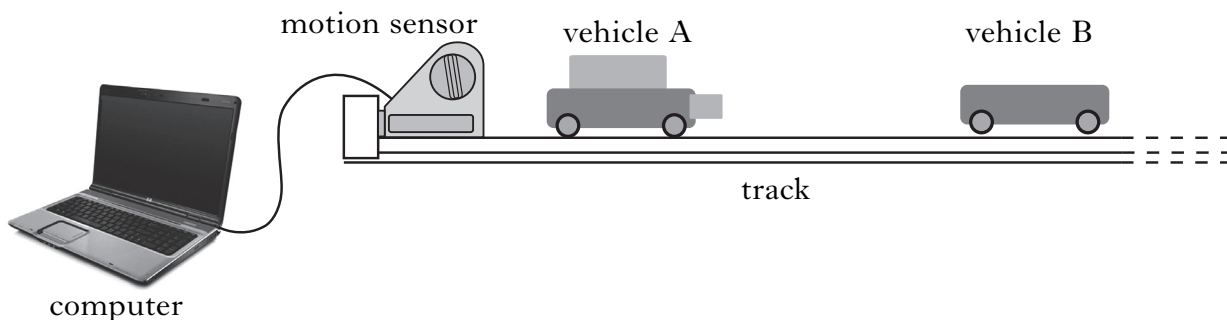

The mass of vehicle A is 0.22 kg and the mass of vehicle B is 0.16 kg.

The effects of friction are negligible.

(a) During one experiment the vehicles collide and stick together. The computer connected to the motion sensor displays the velocity-time graph for vehicle A.

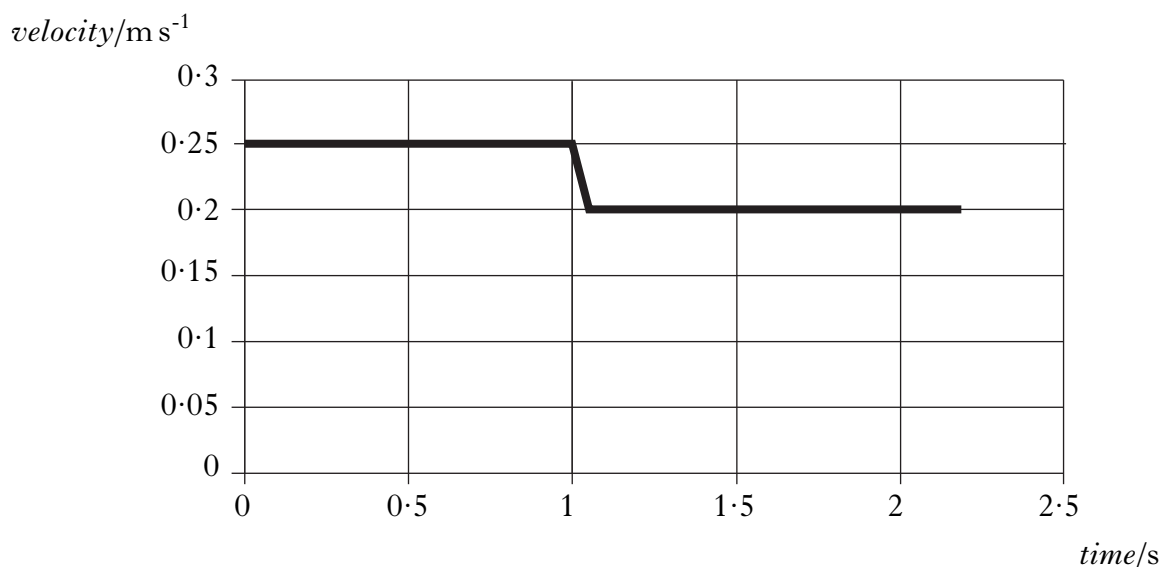

(i) State the law of conservation of momentum. 1

(ii) Calculate the velocity of vehicle B before the collision. 2

(b) The same apparatus is used to carry out a second experiment.

In this experiment, vehicle B is stationary before the collision.

Vehicle A has the same velocity before the collision as in the first experiment.

After the collision, the two vehicles stick together.

Is their combined velocity less than, equal to, or greater than that in the first collision?

Justify your answer.

2
(5)

23. (a) A gymnast of mass 40 kg is practising on a trampoline.

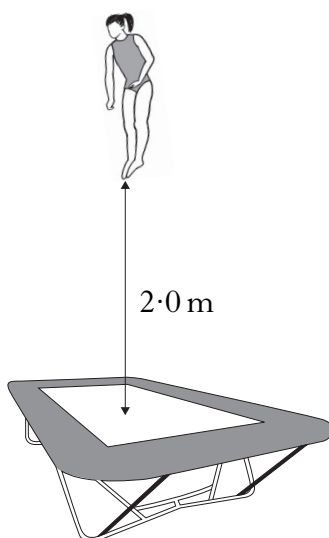

- (i) At maximum height the gymnast's feet are 2.0 m above the trampoline. Show that the speed of the gymnast, as she lands on the trampoline, is 6.3 m s^{-1} . 1
- (ii) The gymnast rebounds with a speed of 5.7 m s^{-1} . Calculate the change in momentum of the gymnast. 2
- (iii) The gymnast was in contact with the trampoline for 0.50 s. Calculate the average force exerted by the trampoline on the gymnast. 2

23. (continued)

- (b) Another gymnast is practising on a piece of equipment called the rings. The gymnast grips two wooden rings suspended above the gym floor by strong, vertical ropes as shown in Figure 1.

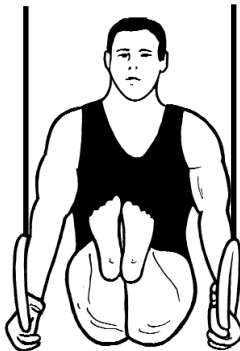

Figure 1

He now stretches out his arms until each rope makes an angle of 10° with the vertical as shown in Figure 2.

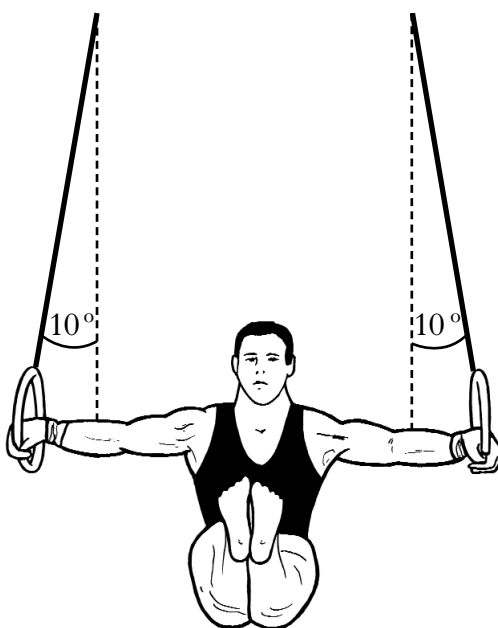

Figure 2

Explain why the tension in each rope increases as the gymnast stretches out his arms.

2
(7)

[Turn over

24. An experiment is carried out to measure the time taken for a steel ball to fall vertically through a fixed distance using an electronic timer.

(a) The experiment is repeated and the following values for time recorded.

0.49 s, 0.53 s, 0.50 s, 0.50 s, 0.55 s, 0.51 s.

Calculate:

(i) the mean value of the time; 1

(ii) the approximate random uncertainty in the mean value of the time. 1

(b) Part of the circuit in the electronic timer consists of a 1.6 mF capacitor and an 18 k Ω resistor connected to a switch and a 4.5 V supply.

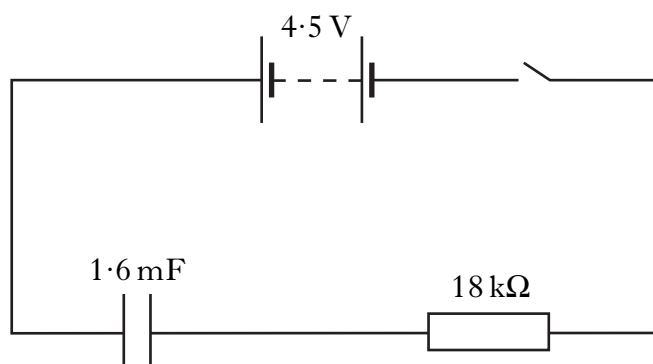

(i) Calculate the charge on the capacitor when it is fully charged. 2

(ii) Sketch the graph of the current in the resistor against time as the capacitor charges.

Numerical values are required on the current axis. 2

(6)

25. The headlights on a truck are switched on automatically when a light sensor detects the light level falling below a certain value. Marks

The light sensor consists of an LDR connected in a Wheatstone bridge as shown.

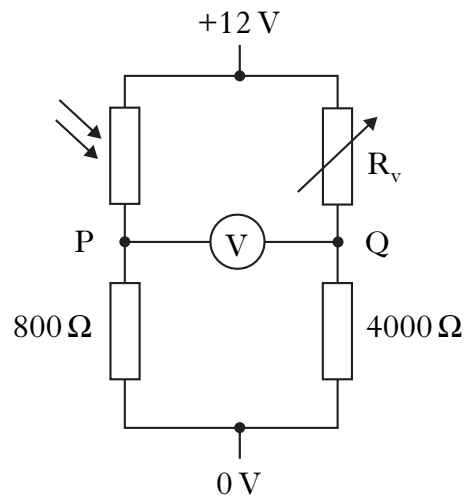

- (a) The variable resistor, R_v , is set at 6000Ω .
- (i) Calculate the resistance of the LDR when the bridge is balanced. 2
 - (ii) As the light level decreases, the resistance of the LDR increases. Calculate the reading on the voltmeter when the resistance of the LDR is 1600Ω . 2
- (b) The Wheatstone bridge is connected to an op-amp as shown. The output of the op-amp controls the headlights circuit.

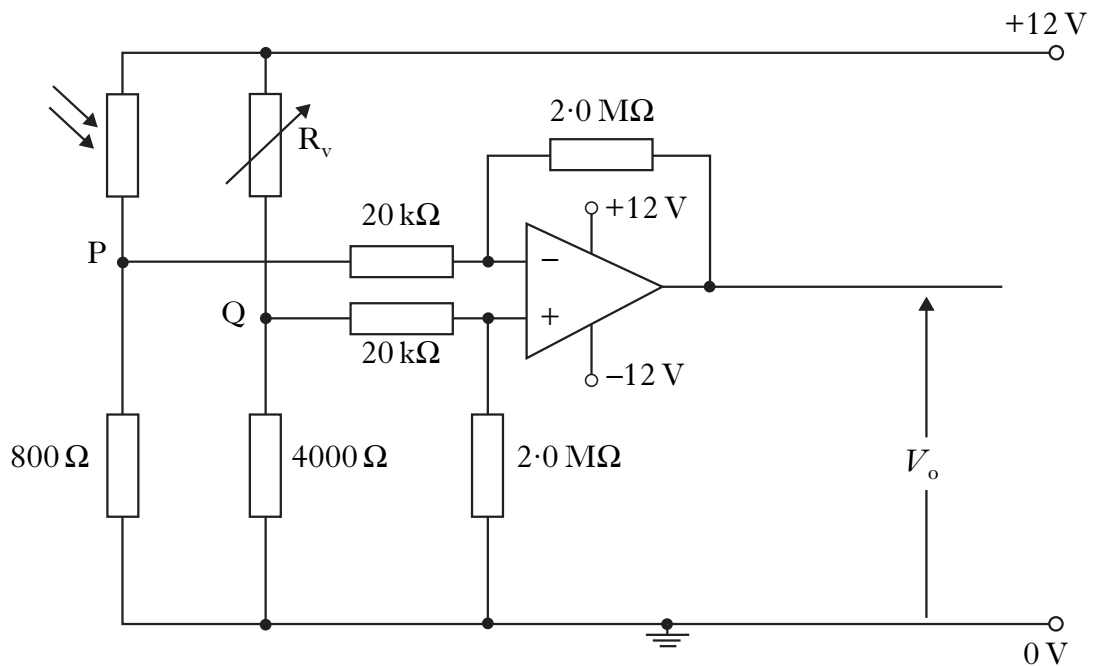

The resistance of R_v is adjusted so that the potential at Q is 3.2 V . At a particular light level, the potential at P is 3.0 V . Determine the output voltage, V_o , of the op-amp.

3
(7)

26. A signal generator is connected to a lamp, a resistor and an ammeter in series. An oscilloscope is connected across the output terminals of the signal generator.

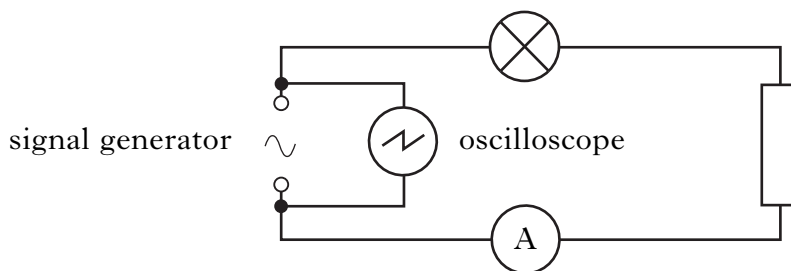

The oscilloscope control settings and the trace displayed on its screen are shown.

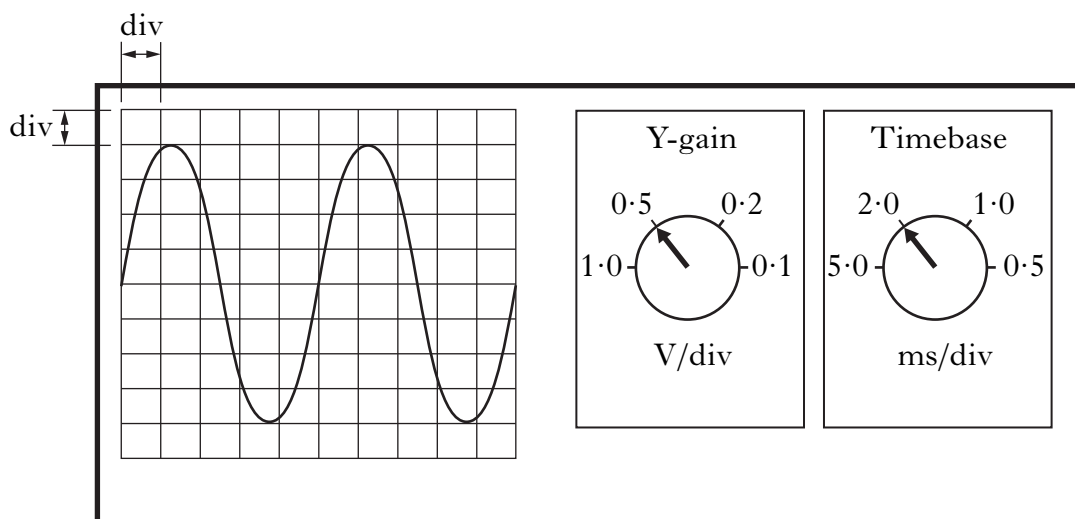

- (a) For this signal calculate:
- the peak voltage; 1
 - the frequency. 2
- (b) The frequency is now doubled. The peak voltage of the signal is kept constant. State what happens to the reading on the ammeter. 1
- (c) The resistor is now replaced by a capacitor. The procedure in part (b) is repeated. State what happens to the reading on the ammeter as the frequency is doubled. 1
- (d) The capacitor will be damaged if the potential difference across it exceeds 16 V. The capacitor is now removed from this circuit and connected to a different a.c. supply of output $15 V_{\text{r.m.s.}}$. Explain whether or not the capacitor is damaged. 2
- (7)**

27. A student is carrying out an experiment to investigate the interference of sound waves. She sets up the following apparatus.

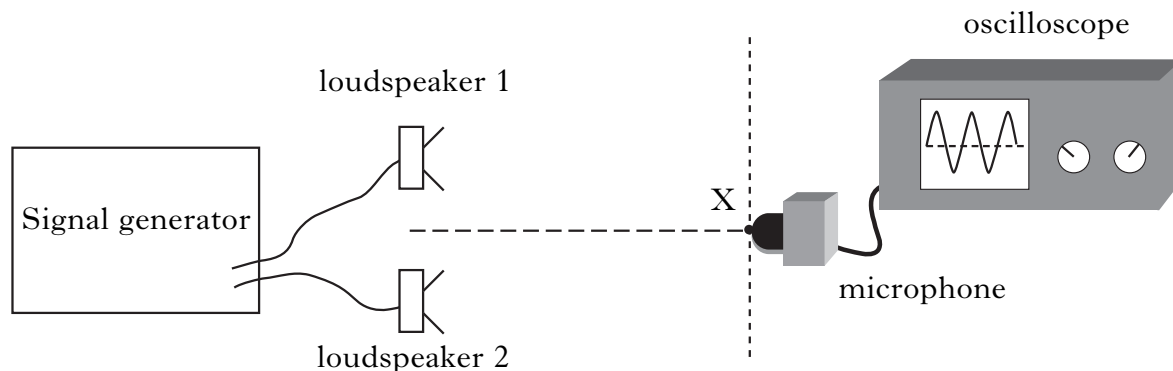

The microphone is initially placed at point X which is the same distance from each loudspeaker. A maximum is detected at X.

- (a) The microphone is now moved to the first minimum at Y as shown.

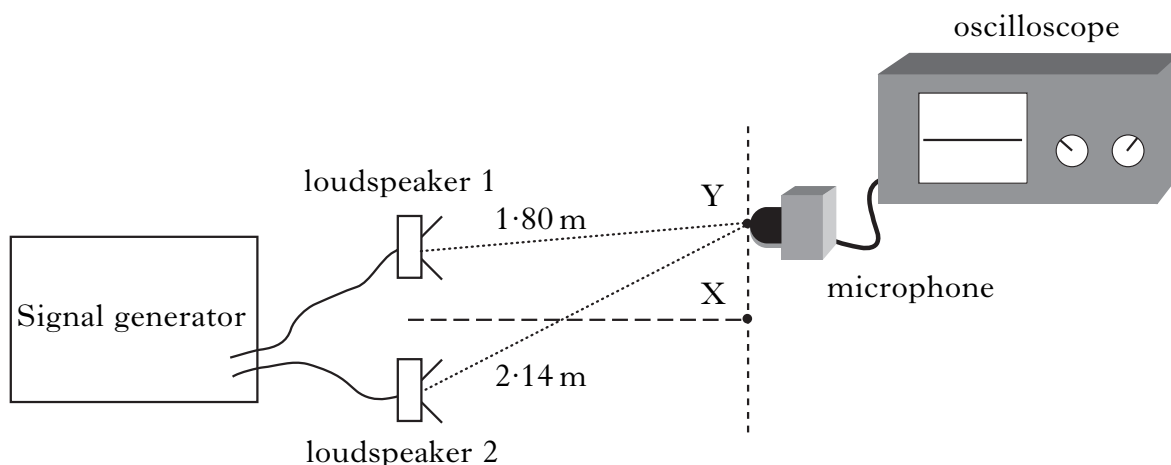

Calculate the wavelength of the sound waves.

2

- (b) Loudspeaker 1 is now disconnected.

What happens to the amplitude of the sound detected by the microphone at Y?

Explain your answer.

2

(4)

[Turn over

28. A garden spray consists of a tank, a pump and a spray nozzle.



The tank is partially filled with water.

The pump is then used to increase the pressure of the air above the water.

(a) The volume of the compressed air in the tank is $1.60 \times 10^{-3} \text{ m}^3$.

The surface area of the water is $3.00 \times 10^{-2} \text{ m}^2$.

The pressure of the air in the tank is $4.60 \times 10^5 \text{ Pa}$.

(i) Calculate the force on the surface of the water. 2

(ii) The spray nozzle is operated and water is pushed out until the pressure of the air in the tank is $1.00 \times 10^5 \text{ Pa}$.

Calculate the volume of water expelled. 3

(b) The gardener observes a spectrum when sunlight illuminates the drops of water in the spray. This is because each drop of water is acting as a prism.

The diagram shows the path taken by light of wavelength 650 nm through a drop of water.

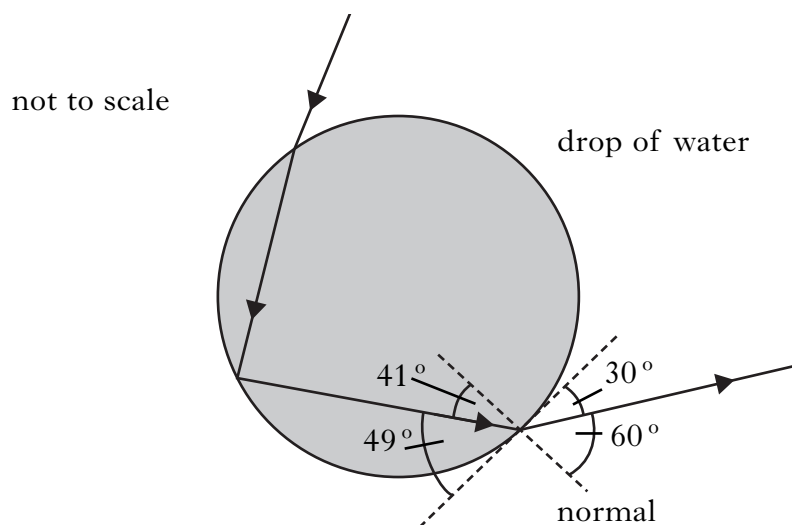

(i) What happens to the frequency of this light when it enters the drop of water? 1

28. (b) (continued)

(ii) Using information from the diagram, calculate the refractive index of the water for this wavelength of light. 2

(iii) Calculate the critical angle for this wavelength of light in the water. 2

(iv) Light of shorter wavelength also passes through the drop of water.

Will the critical angle for this light be less than, equal to, or greater than that for light of wavelength 650 nm?

Justify your answer. 2

(12)

[Turn over

29. A laser produces a beam of light with a frequency of 4.74×10^{14} Hz.

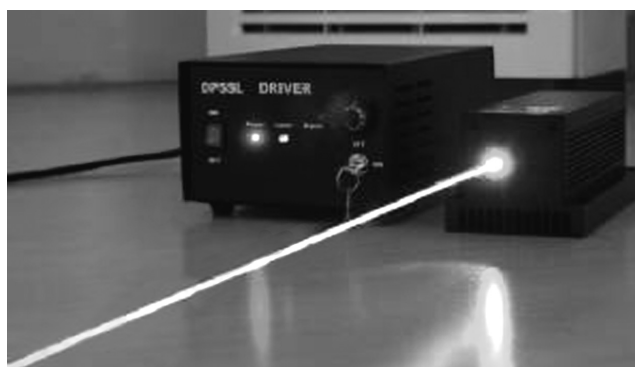

- (a) The laser has a power of 0.10 mW. Explain why light from this laser can cause eye damage. 1
- (b) Calculate the energy of each photon in the laser beam. 2
- (c) Inside the laser, photons stimulate the emission of more photons.
State **two** ways in which the stimulated photons are identical to the photons producing them. 1
- (d) This laser beam is now incident on a grating as shown below.

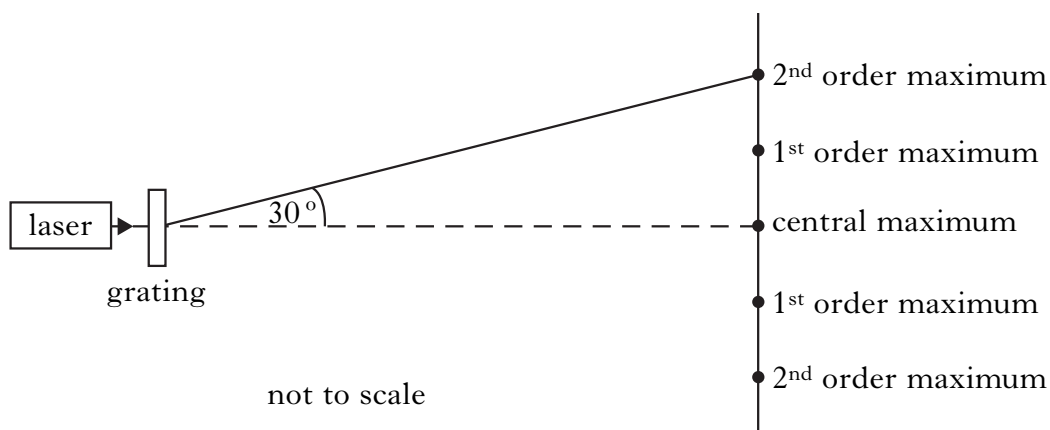

The second order maximum is detected at an angle of 30° from the central maximum.

Calculate the separation of the slits on the grating. 3
(7)

30. A smoke alarm contains a very small sample of the radioactive isotope Americium-241, represented by the symbol

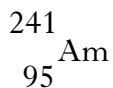

- (a) How many neutrons are there in a nucleus of this isotope? 1
- (b) This isotope decays by emitting alpha particles as shown in the following statement.

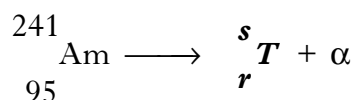

- (i) Determine the numbers represented by the letters *r* and *s*. 1
- (ii) Use the data booklet to identify the element *T*. 1
- (c) The activity of the radioactive sample is 30 kBq. How many decays take place in one minute? 2
- (d) The alarm circuit in the smoke detector contains a battery of e.m.f. 9.0 V and internal resistance 2.0 Ω.

This circuit is shown.

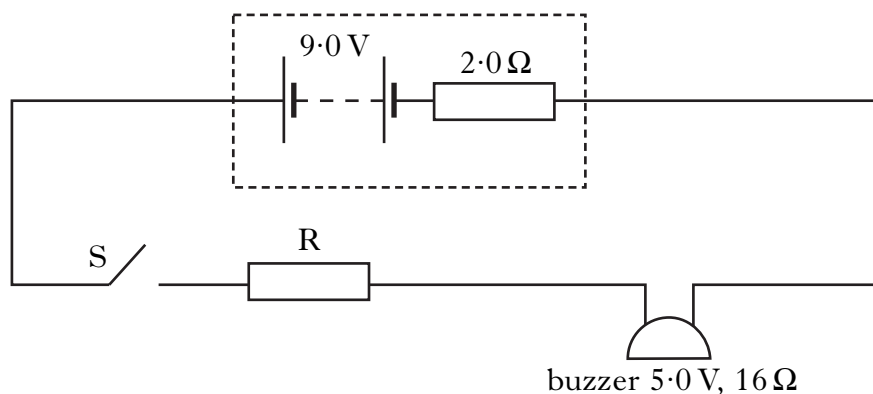

When smoke is detected, switch S closes and the buzzer operates. The buzzer has a resistance of 16 Ω and an operating voltage of 5.0 V.

Calculate the value of resistor R required in this circuit.

3
(8)

[END OF QUESTION PAPER]

[BLANK PAGE]

[BLANK PAGE]

[BLANK PAGE]