

National 3 Lifeskills

Shape, Space & Measures

1. An outline of a pig's pen is shown below:

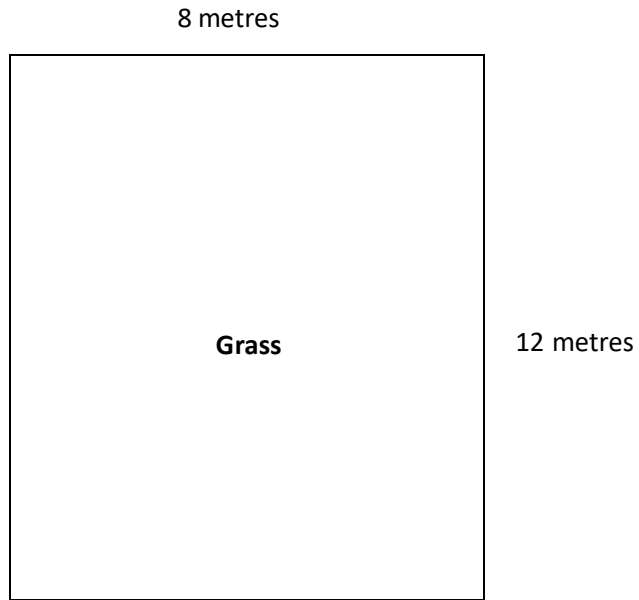

A fence is to be placed all the way around the outside edge of the pen.

- (a) Calculate the total length of fencing needed. (1)



- (b) The whole pen is to be covered in grass.
Calculate the area of the pen to be covered in grass. (1)

Practice 2

2. A water tank is 80 centimetres long, 20 centimetres wide and 45 centimetres high, as shown.

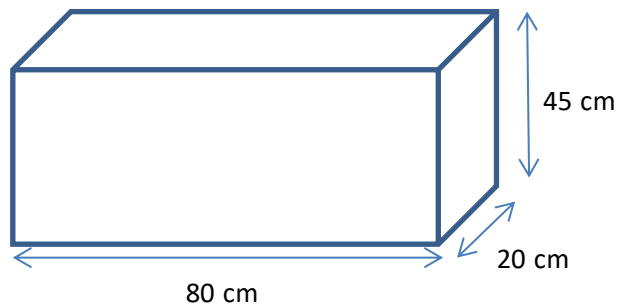

- (a) What formula would you use to calculate the volume of the tank? (1)
- (b) Calculate how much water you need to fill the tank to the top. (1)
- (c) A second fish tank holds **twice as much water**.
How much water does the second fish tank hold? (1)

3.

You have been given the following directions by Ben to help you find your way from school to his house on Main Street.

(a) On the map draw a line to show the route Ben suggests. Follow these directions:

- ◆ Come out of school onto High Street
- ◆ Walk straight onto Bell Avenue
- ◆ Turn right onto Millford Avenue
- ◆ Turn right onto Main Street

(1)

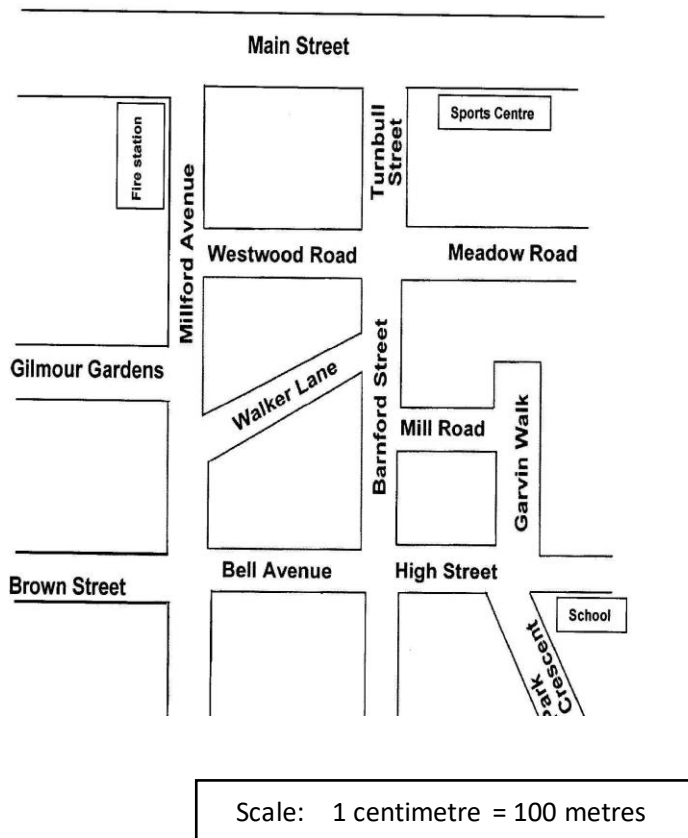

(b) Use the scale to estimate the distance you have to walk.

(1)

(c) Write down directions for Keith to get from Brown Street to the Sports Centre.

(1)

Practice 2

4. A picture of a toy boat is shown below.

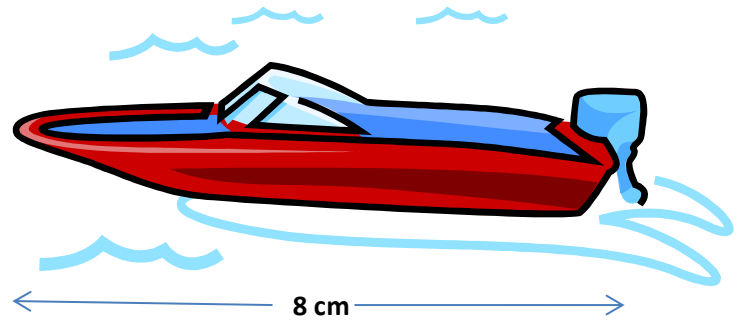

The length of the toy boat is 8 centimetres.

The scale of the toy boat to the real model is:

1 centimetre represents 90 centimetres.

Find the actual length of the real boat.

(1)

5. Nina has made three different patterns from matchsticks. Her designs are shown below.



1

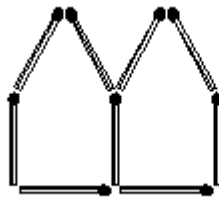

2

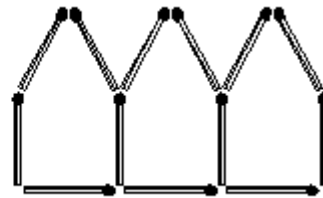

3

- (a) Draw the next design in the sequence.

(1)

- (b) Complete the table below to plan how many matchsticks you need for more patterns

(1)

Design number	1	2	3	4	5	6
Number of matchsticks	5	9				

- (c) How many matchsticks would be needed for design number 12?

(1)

Practice 2

6. Peter leaves his house in Motherwell at 8.35 am and drives to Aberdeen.
The journey takes him 2 hours 45 minutes.

What time will he arrive in Aberdeen?

(1)

7. Hannah is going from Livingston to Edinburgh by train.
The trains run at regular intervals.

Part of the train timetable is shown below:

Train timetable

Depart: Livingston	1236	1251	1306					
Arrive: Edinburgh	1300	1315	1330					

- (a) Complete the timetable to show the departure and arrival times of the next five trains. (1)
- (b) Hannah has decided to catch the train which leaves Livingston at 1436.
What time should she arrive at Edinburgh? (1)

[End of Questions]

Practice 2

Answers

Q1a	<ul style="list-style-type: none"> • $8 + 12 + 8 + 12 = 40$ metres 														
Q1b	<ul style="list-style-type: none"> • $12 \times 8 = 96 \text{ m}^2$ 														
Q2a	<ul style="list-style-type: none"> • $V = lbh$ or $V = l \times b \times h$ 														
Q2b	<ul style="list-style-type: none"> • $80 \times 20 \times 45$ • 72000 • cm^3 														
Q2c	<ul style="list-style-type: none"> • $2 \times 72000 = 144000 \text{ cm}^3$ (ignore units) 														
Q3a	<ul style="list-style-type: none"> • Check paper 														
Q3b	<ul style="list-style-type: none"> • Approximately 12cm = 1200m (must be in metres) 														
Q3c	<ul style="list-style-type: none"> • Correct directions 														
Q4	<ul style="list-style-type: none"> • 720 cm 														
Q5a	<ul style="list-style-type: none"> • 4 house shapes with 17 matchsticks 														
Q5b	<table border="1" style="margin-left: auto; margin-right: auto;"> <tr> <td>Design Number</td> <td>1</td> <td>2</td> <td>3</td> <td>4</td> <td>5</td> <td>6</td> </tr> <tr> <td>Number of matchsticks</td> <td>5</td> <td>9</td> <td>13</td> <td>17</td> <td>21</td> <td>25</td> </tr> </table>	Design Number	1	2	3	4	5	6	Number of matchsticks	5	9	13	17	21	25
Design Number	1	2	3	4	5	6									
Number of matchsticks	5	9	13	17	21	25									
Q6	<ul style="list-style-type: none"> • 11.25am 														
Q7a	<ul style="list-style-type: none"> • Top row - 1321, 1336, 1351, 1406, 1421 • Bottom Row - 1345, 1400, 1415, 1430, 1445 														
Q7b	<ul style="list-style-type: none"> • 1500 														