

N4 N5 Physics

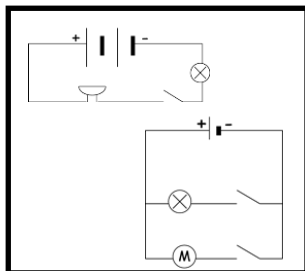
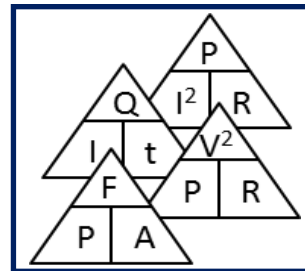
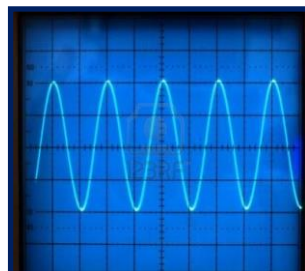
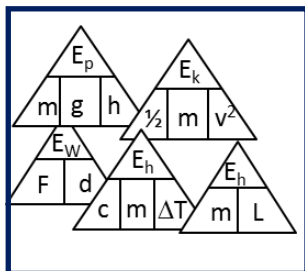
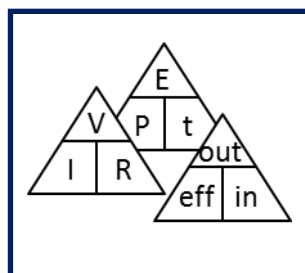

$$R_{\text{series}} = R_1 + R_2 + R_3 \dots$$

$$1 / R_{\text{parallel}} = 1 / R_1 + 1 / R_2 + 1 / R_3 \dots$$

$$\% \text{efficiency} = (\text{output} / \text{input}) \times 100$$

$$P_1 V_1 / T_1 = P_2 V_2 / T_2$$

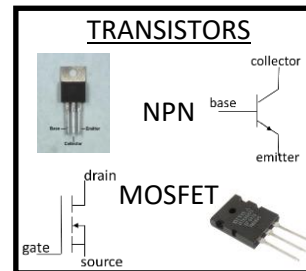

Electricity & Energy Problems

DATA SHEET

Speed of light in materials

Material	Speed in m s^{-1}
Air	3.0×10^8
Carbon dioxide	3.0×10^8
Diamond	1.2×10^8
Glass	2.0×10^8
Glycerol	2.1×10^8
Water	2.3×10^8

Speed of sound in materials

Material	Speed in m s^{-1}
Aluminium	5200
Air	340
Bone	4100
Carbon dioxide	270
Glycerol	1900
Muscle	1600
Steel	5200
Tissue	1500
Water	1500

Gravitational field strengths

	Gravitational field strength on the surface in N kg^{-1}
Earth	9.8
Jupiter	23
Mars	3.7
Mercury	3.7
Moon	1.6
Neptune	11
Saturn	9.0
Sun	270
Uranus	8.7
Venus	8.9

Specific heat capacity of materials

Material	Specific heat capacity in $\text{J kg}^{-1} \text{ } ^\circ\text{C}^{-1}$
Alcohol	2350
Aluminium	902
Copper	386
Glass	500
Ice	2100
Iron	480
Lead	128
Oil	2130
Water	4180

Specific latent heat of fusion of materials

Material	Specific latent heat of fusion in J kg^{-1}
Alcohol	0.99×10^5
Aluminium	3.95×10^5
Carbon Dioxide	1.80×10^5
Copper	2.05×10^5
Iron	2.67×10^5
Lead	0.25×10^5
Water	3.34×10^5

Melting and boiling points of materials

Material	Melting point in $^\circ\text{C}$	Boiling point in $^\circ\text{C}$
Alcohol	-98	65
Aluminium	660	2470
Copper	1077	2567
Glycerol	18	290
Lead	328	1737
Iron	1537	2737

Specific latent heat of vaporisation of materials

Material	Specific latent heat of vaporisation in J kg^{-1}
Alcohol	11.2×10^5
Carbon Dioxide	3.77×10^5
Glycerol	8.30×10^5
Turpentine	2.90×10^5
Water	22.6×10^5

Radiation weighting factors

Type of radiation	Radiation weighting factor
alpha	20
beta	1
fast neutrons	10
gamma	1
slow neutrons	3

1. Current and Electrical Charge

National 5

In this section you can use the equation:

$$\text{charge} = \text{current} \times \text{time}$$

also written as

$$Q = I t$$

where **Q** = charge in coulombs (C)
I = current in amperes (A)
t = time in seconds (s).

1. Find the missing values in the following table.

	<i>Charge (C)</i>	<i>Current (A)</i>	<i>Time (s)</i>
(a)		5	30
(b)		0.005	3 600
(c)	3	1.5	
(d)	27.6	2.3	
(e)	1 800		60
(f)	94		10

2. A bulb draws a current of 1 A. How much charge flows through it in 60 seconds?

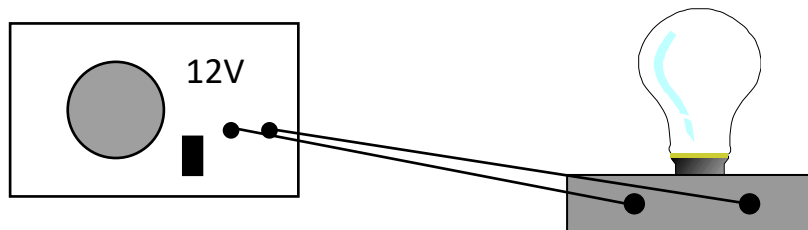

3. 756 C of charge flow through an electric heater in 180 seconds. What is the current in the heater?
4. A hairdryer operates with a current of 5 A. How much time would it take for 6 000 C to pass through the hairdryer?

5.

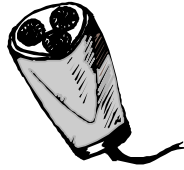

A current of 2.1 A flows through an electric shaver for 5 minutes. How much charge flows in this time?

6. A 60 W bulb is switched on for 30 minutes. If 450 C pass through it in this time, what is the current flowing in the bulb?
7. A 'surround sound' speaker system on a TV draws a current of 0.6 A. In an average day 6 480 C of charge flows through the speaker system. For how long is the TV switched on each day?

8. An electric kettle has a label on it as shown below.

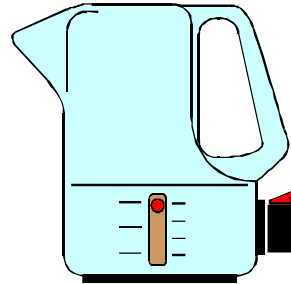
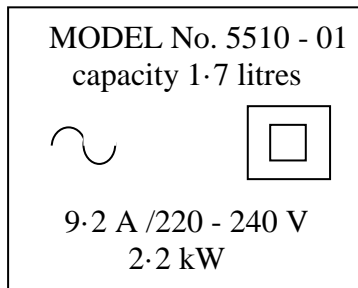

After the kettle is switched on it automatically switches off when the water in it has boiled. On one occasion 1 656 C passed through the kettle before it switched off. Use the information given to work out how long the water took to boil?

9. An electric fire is rated at 2.875 kW, 230 V, 12.5 A. How much charge will flow through this fire in a period of 2 hours 20 minutes?
10. One day an electric iron was switched on from 1.45 p.m. until 3.15 p.m. What current was drawn by the iron if 2.484×10^4 C passed through it in this time?

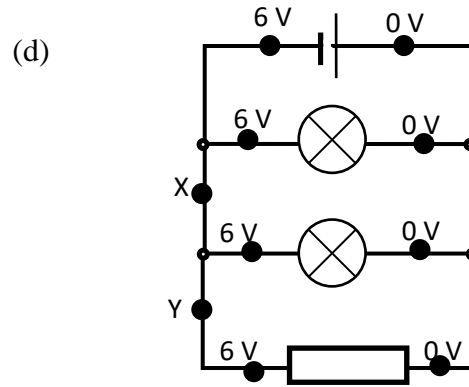
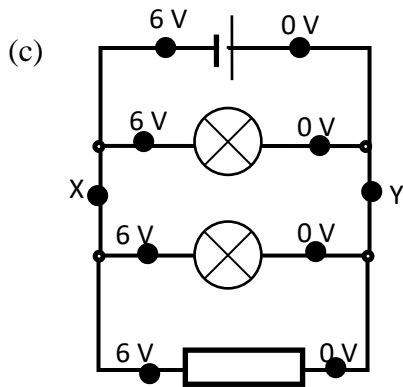

5. Which of the following statements correctly explains what is meant by a “12 V supply”.
- A 12 volts are supplied to each coulomb of charge.
 - B 12 joules of energy are supplied to each coulomb of charge.
 - C 12 joules of energy are supplied each second.
 - D 12 coulombs of charge pass through each second.
 - E 12 coulombs of charge are supplied to each joule of energy.

3. AC and DC

National 5

1. D.C. stands for Direct Current. Explain what is meant by this in terms of the size and direction of the electric current.
2. A.C. stands for Alternating Current. Explain what is meant by this in terms of the size and direction of the electric current.
3. State the size and frequency of the mains voltage.
4. For each of the following, state whether d.c. or a.c. is produced.
 - (a) the mains electricity supply
 - (b) a car battery

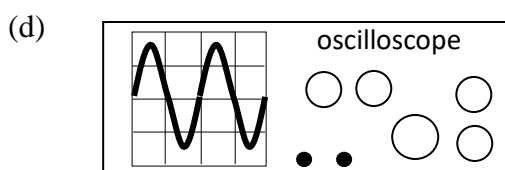
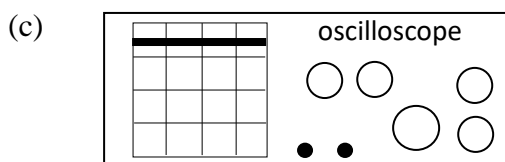

5. (Extension question)
Voltage can be measured using an oscilloscope by multiplying the “volts per division” setting by the number of divisions (or boxes) between the signal and the centre “zero” line on the oscilloscope grid. For an a.c. signal, the “peak voltage” is the maximum voltage reached in any cycle.

For each of the following signals, determine the d.c. voltage or the a.c. peak voltage shown. The “volts per division” setting is given in each case.

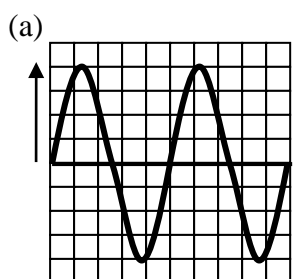

3 volts per division

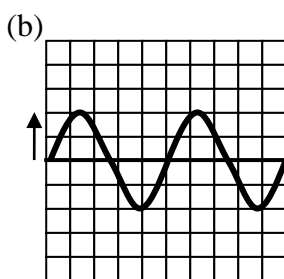

1.5 volts per division

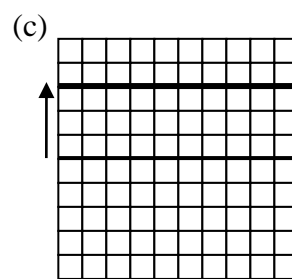

0.5 volts per division

4. Basic Electrical Components

National 4 and 5

1. Find out and draw the symbol for each of the following electrical and electronic components:
 - (a) lamp
 - (b) connecting lead
 - (c) battery
 - (d) cell
 - (e) motor
 - (f) resistor
 - (g) switch
 - (h) variable resistor
 - (i) voltmeter
 - (j) ammeter
 - (k) fuse
 - (l) buzzer
 - (m) bell

2. Draw a circuit consisting of one lamp, one switch, one battery and one buzzer connected in series.

3. Draw a circuit that will allow 3 bulbs to be switched on and off separately. Each bulb will require its own switch. The circuit should operate from 2 batteries connected in series.

5. Measuring Current, Voltage and Resistance

National 4 and 5

1. A student sets up a circuit, as shown below, in order to switch on a lamp.

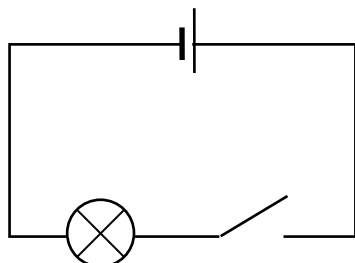

The student wants to measure the voltage across the lamp and the current through it.

- (a) What should the student use in order to measure the voltage across the lamp?
 - (b) What should be used to measure the current in the lamp?
 - (c) Redraw the circuit to show the correct positions of these meters.
 - (d) Draw a circuit to show how the student could measure the resistance of the lamp directly.
2. The following circuit is set up to investigate the effect of resistance on current.

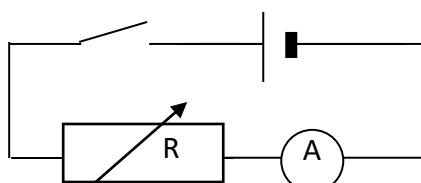

- (a) Describe what happens to the ammeter reading as the resistance of the variable resistor is increased.
- (b) Present the results in the following table as a line graph:

Resistance (Ω)	100	200	300	400	500
Current (A)	0.120	0.060	0.040	0.030	0.025

3. The resistance of the variable resistor, in the circuit below, is decreased. Describe and explain what happens to the brightness of the lamp as the resistance decreases.

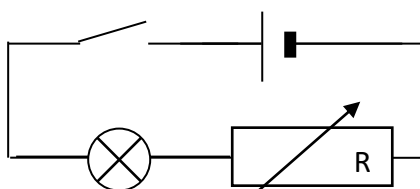

6. Current and Voltage in Series Circuits

National 4 and 5

Helpful Hint

The rules for **series** circuits are:

1. the **current is the same** at all points in the circuit
2. the **voltage of the source is shared** amongst the components in the circuit.

1. Two identical 2.5 V bulbs are connected to a supply as shown. Determine the voltage of the supply.

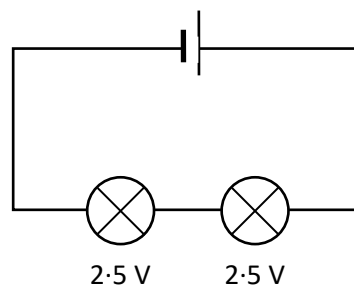

2. Four identical resistors are connected across a 12 V supply as shown in the diagram. Determine the voltage across each of the resistors.

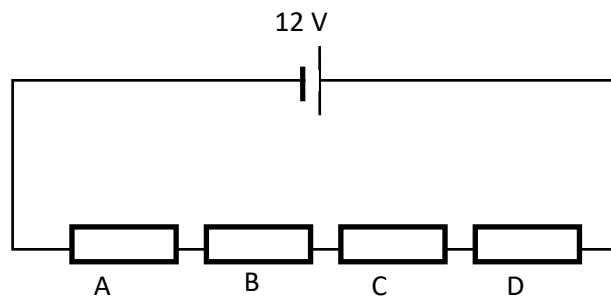

3. A simple circuit with a bulb and resistor in series is shown below.

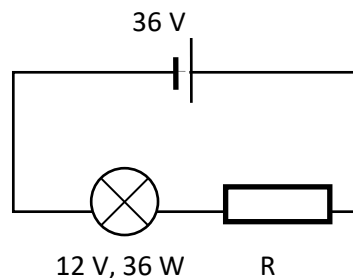

- (a) The bulb is operating at its correct voltage and power rating. Determine the voltage across resistor R.
- (b) The current in the bulb is 3 A. Determine the current flowing in the resistor.

4. Two resistors are connected in series to a supply as shown in the diagram.

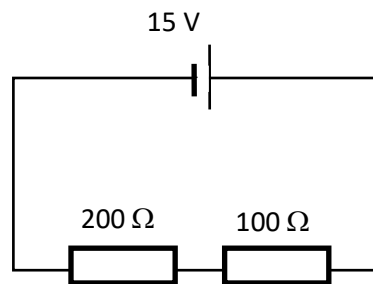

- (a) The current in the $200\ \Omega$ resistor is $0.05\ \text{A}$. Determine the current in the other resistor.
- (b) The voltage across the $100\ \Omega$ resistor is $5\ \text{V}$. Determine the voltage across the $200\ \Omega$ resistor.
5. A rheostat is used as a dimmer switch in a simple series circuit as shown.

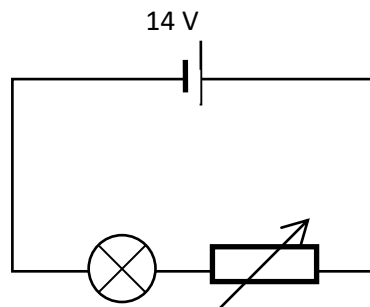

The rheostat is adjusted until the bulb is shining brightly. The voltage across the bulb is $13.8\ \text{V}$ and the current through the rheostat at this setting is $1.7\ \text{A}$.

- (a) Calculate the voltage across the rheostat.
- (b) Determine the current flowing in the bulb.

7. Current and Voltage in Parallel Circuits

National 5

Helpful Hint

The rules for **parallel** circuits are:

1. the **voltage is the same** across all the components in parallel.
2. the **current from the supply is shared** amongst the different branches of the circuit.

1. Two resistors are connected in parallel to a 12 V battery.

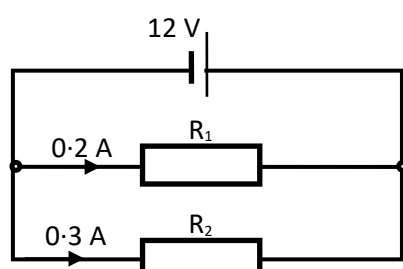

- (a) Determine the voltage across R_1 .
- (b) Determine the voltage across R_2 .
- (c) Calculate the current drawn from the battery.

2. Two identical bulbs and a resistor are connected in parallel to a 6 V supply.

- (a) Determine the voltage across L_2 .
- (b) A current of 1.8 A flows through each of the bulbs. Calculate the current flowing through the resistor.

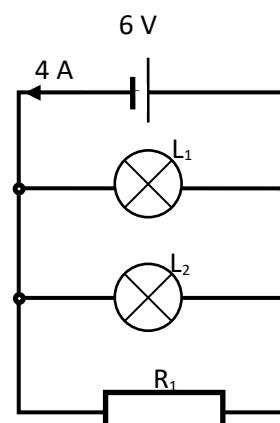

3. An electric fire has three elements which can be switched on and off independently. The elements are connected in parallel to the mains supply. Each element draws a current of 0.3 A when switched on.

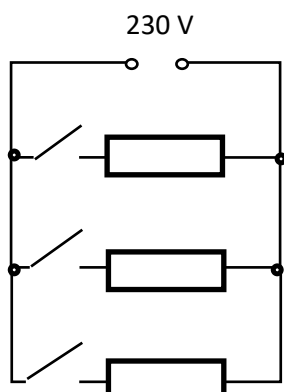

- (a) Determine the voltage across the middle element.
- (b) Calculate the total current flowing from the supply when two of the elements are switched on.
- (c) Calculate the maximum current drawn from the mains by the fire.

4. The headlamps and side lights in a car are connected in parallel. The diagram below shows how they are connected. The side lights (L_1 & L_2) may be switched on by themselves using switch S_1 . The headlamps (H_1 & H_2) are switched on by switch S_2 and only come on if the sidelights are already on.

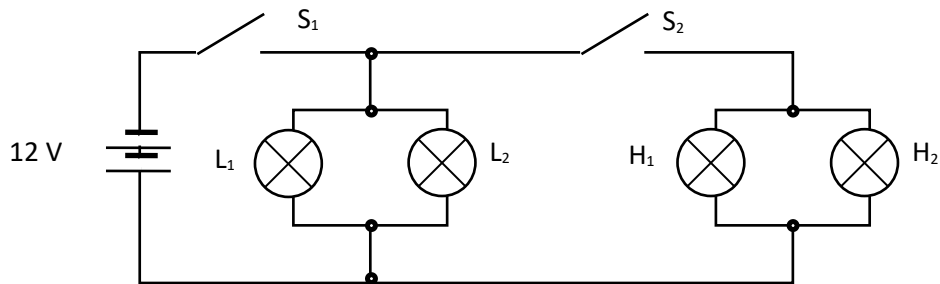

- Determine the voltage across the sidelight L_1 .
 - Determine the voltage across the headlight H_2 .
 - Each sidelight draws a current of 3 A from the car battery. Calculate the total current drawn from the battery when S_1 only is closed.
 - Each headlight draws a current of 5 A from the car battery. Calculate the total current drawn from the battery when S_1 and S_2 are closed.
5. A hairdryer contains a motor and heating elements (resistors). The hairdryer shown below has three heat settings- cold, warm and hot. The circuit diagram shows how these settings are achieved using switches A, B and C.

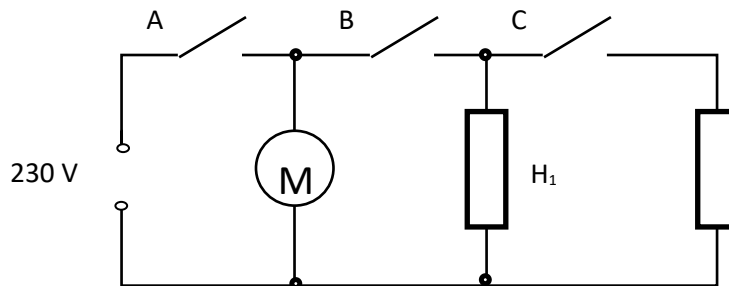

The motor draws a current of 3 A from the mains and the heating elements draw a current of 2 A each from the mains.

- State which switches must be closed to make the hairdryer blow warm air.
- Calculate the current drawn from the mains when the hairdryer blows warm Air.
- State which switches must be closed to make the hairdryer blow hot air.
- Calculate the current drawn from the mains when the hairdryer blows hot air.
- Determine the minimum current drawn when the hairdryer is on.
- Determine the voltage across the motor.

8. Circuit Applications

National 4

1. Junior Spark tries his hand at some DIY electrics in and around his new home. He designs two circuits. Circuit 1 is a model for a room light and Circuit 2 is a model for toy car lights. His designs are shown below.

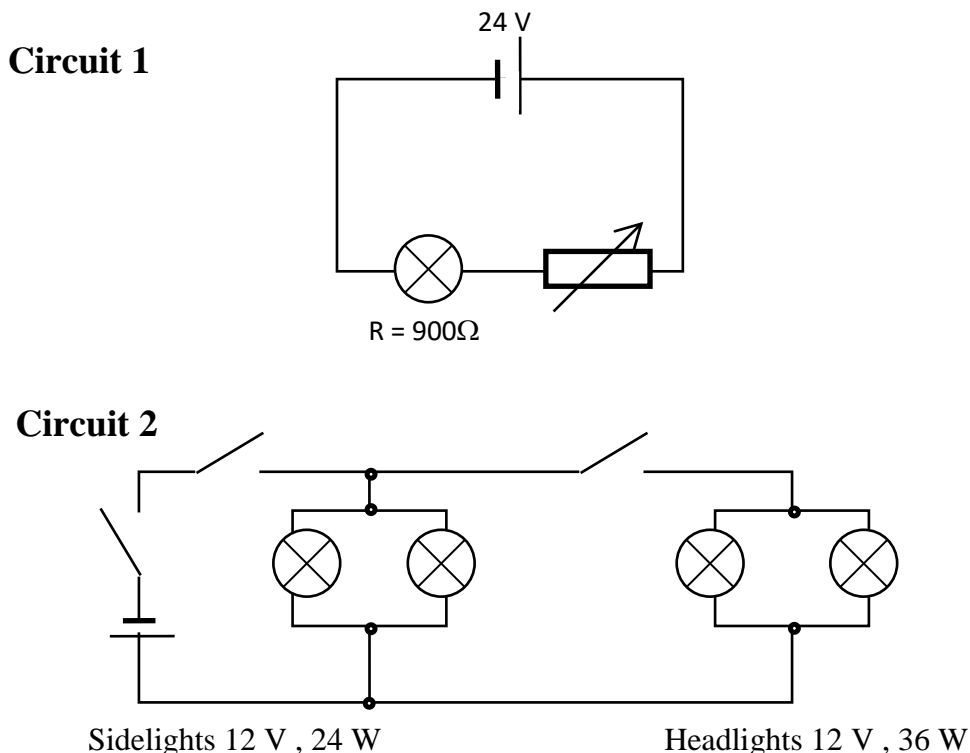

Look at the circuits and answer the following questions.

- (a) Describe the function of the variable resistor in circuit 1.
- (b) In circuit 2, which switches must be closed to switch on the head lights?
- (c) What is the advantage of having the sidelights and the headlights connected in parallel instead of in series with one another?
2. Give 2 examples from a typical house where 2 switches are connected in series to operate an electrical device.
3. Does household wiring connect ceiling lights in series or in parallel?
4. Why do modern houses have circuit breakers instead of fuses?
5. (Homework task!) Find out what the various circuits are in your own household wiring. You can do this by checking your “fuse box” which will usually have each circuit labelled.

9. Ohm's Law

National 4 and 5

In this section you can use the equation:

$$\text{voltage} = \text{current} \times \text{resistance}$$

also written as:

$$V = IR$$

where **V** = voltage in volts (V)
I = current in amps (A)
R = resistance in ohms (Ω).

Helpful Hint.

Many appliances run from **mains** voltage which is **230 V** ac.

Useful units for electricity are:

$$1 \mu\text{A} = 0.000\,001 \text{ A} = 1 \times 10^{-6} \text{ A}$$

$$1 \text{ mA} = 0.001 \text{ A} = 1 \times 10^{-3} \text{ A}$$

1. Find the missing values in the following table.

	Voltage (V)	Current (A)	Resistance (Ω)
(a)		15	35
(b)		0.2	1 000
(c)	230		125
(d)	24		550
(e)	120	12	
(f)	6	6.25×10^{-3}	

2. Look at the following circuits and calculate the supply voltage in each case:

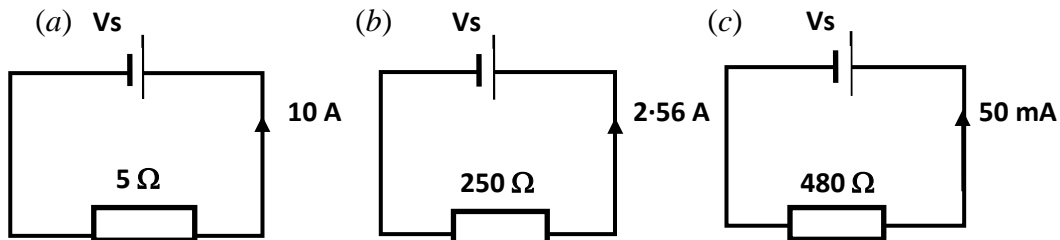

3. Look at the following circuits and calculate the current in each case:

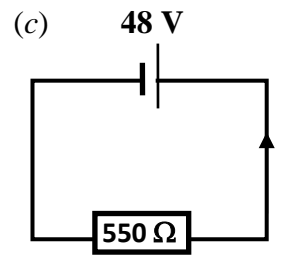
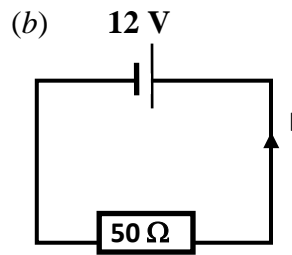
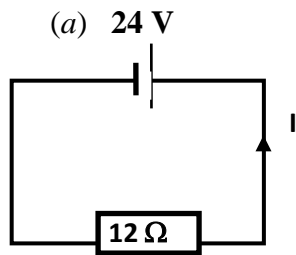

4. Look at the following circuits and calculate the unknown resistance in each case:

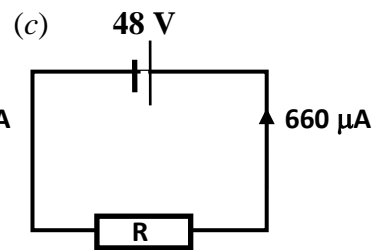
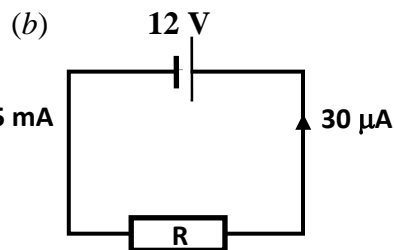
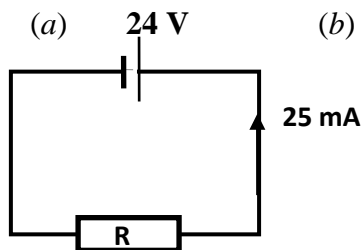

5. Calculate the resistance of a lamp if the current through it is 10 mA when operated by a 24 V supply.
6. A power drill is operated at mains voltage and has a resistance of 1.5 kΩ. Calculate the current through the drill.
7. The maximum current an electric motor can safely handle is 10 mA and it has a resistance of 360 Ω. Calculate its safe operating voltage.
8. A cooker draws a maximum current of 28.75 A and has a resistance of 8 Ω. At what voltage should it operate?
9. Hairdryers work from the mains voltage and can have currents of up to 15 mA flowing through them. Calculate the resistance of the hairdryer.
10. Overhead cables have resistance of 25 kΩ. If the voltage across the cables is 4 000 V calculate the current through them.

10. Resistance in Series

National 5

In this section you can use the equation:

$$R_s = R_1 + R_2 + R_3 + \dots$$

where R_s = total resistance of a series circuit or series section of a circuit (Ω).

1. Three resistors R_1 , R_2 and R_3 are arranged in series as shown in the diagram below.

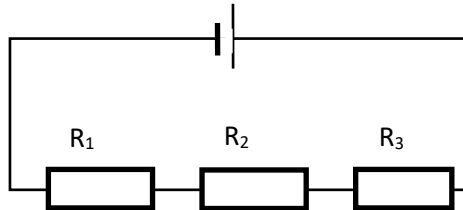

Find the missing values in the table.

	R_1 (Ω)	R_2 (Ω)	R_3 (Ω)	R_s (Ω)
(a)	5 000	490	85	
(b)	80	300	25	
(c)	800	2 000	200	
(d)	700	300		1 400
(e)		140	100	550
(f)	225		85	390

2. Calculate the total resistance of the following circuit.

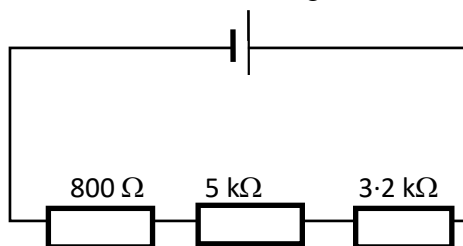

3. The resistance of the following circuit is $8.8 \text{ k}\Omega$. Calculate the resistance of R .

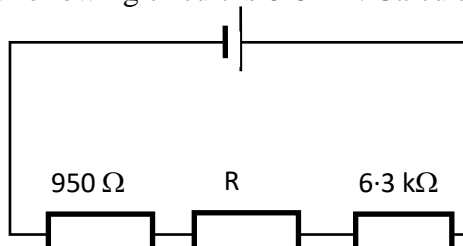

11. Resistance in Parallel

National 5

In this section you can use the equation

$$\frac{1}{R_p} = \frac{1}{R_1} + \frac{1}{R_2} + \frac{1}{R_3} + \dots$$

where R_p = total resistance of a parallel circuit or parallel section of a circuit (Ω).

1. Calculate the total resistance of each of the following circuits:

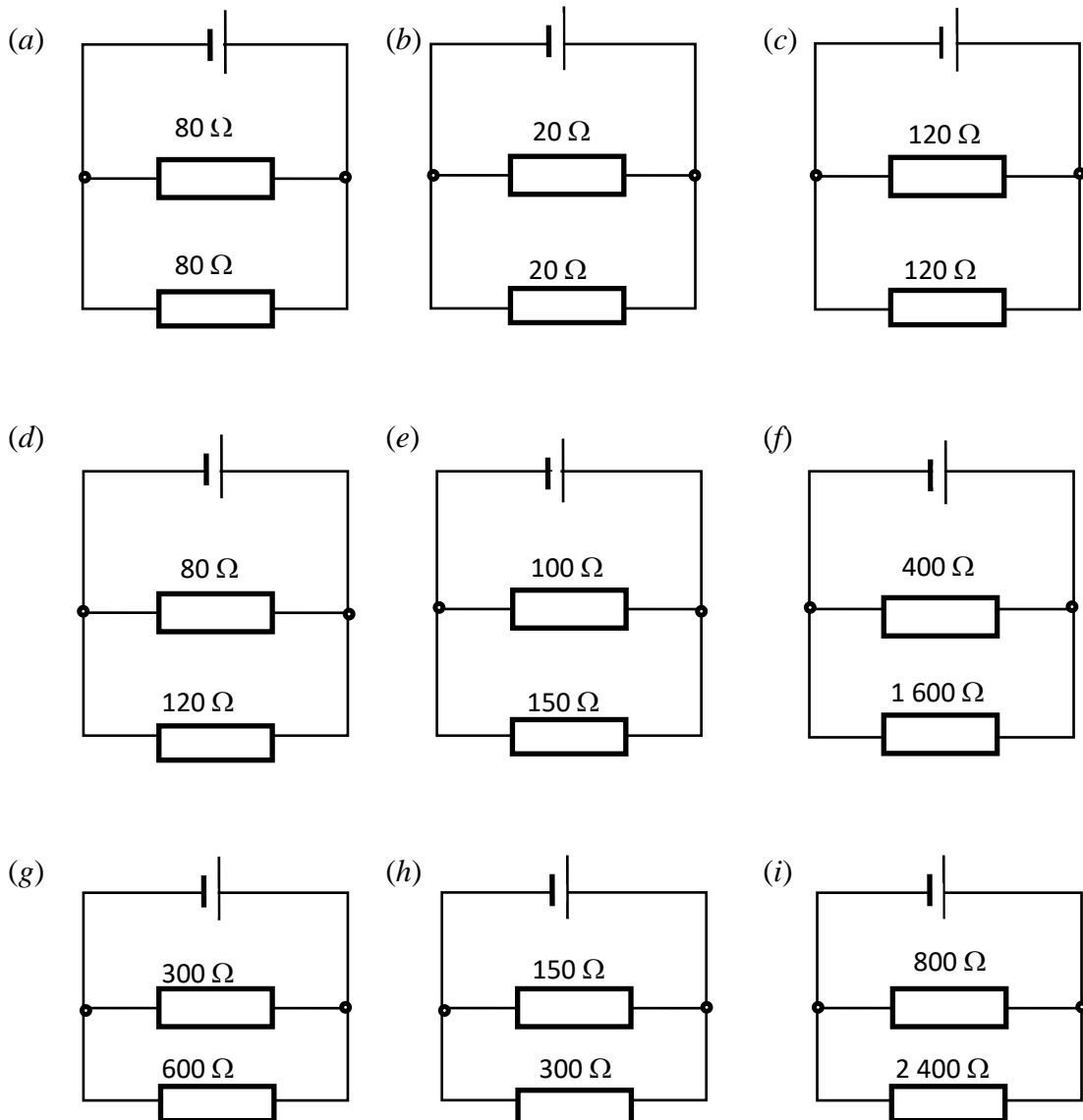

2. Calculate the total resistance of each of the following circuits:

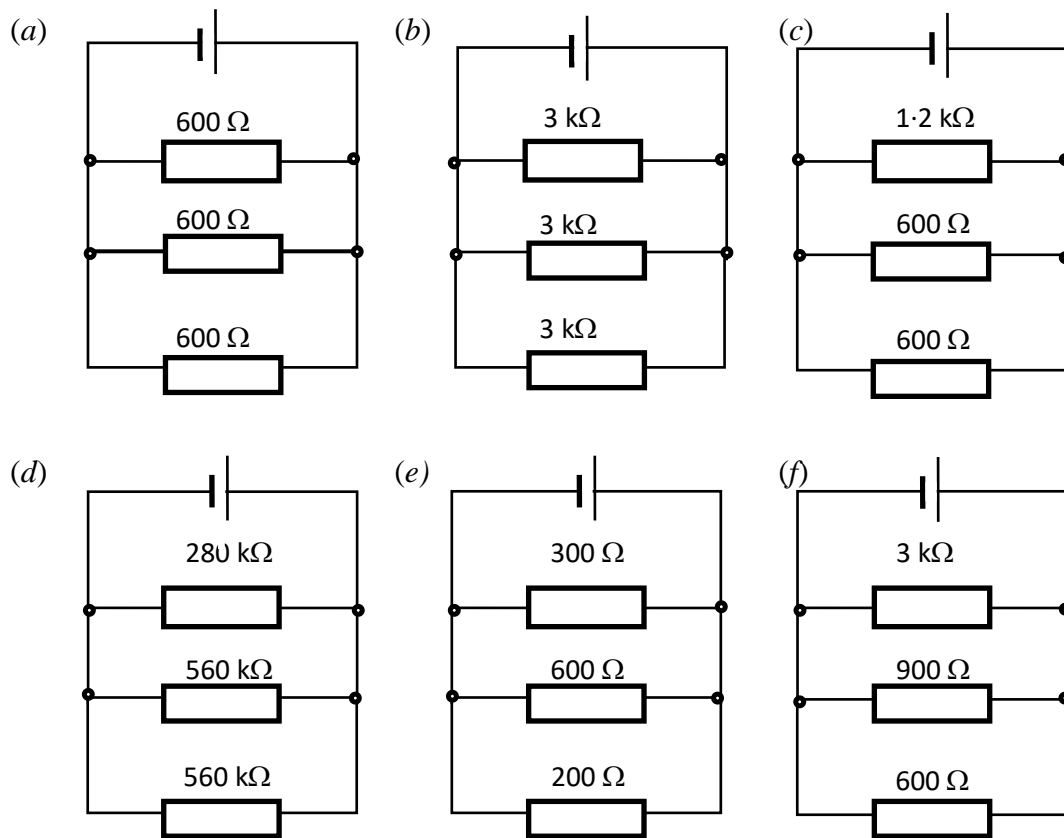

3. The total resistance of the circuit below is $80\ \Omega$. Calculate the resistance of R .

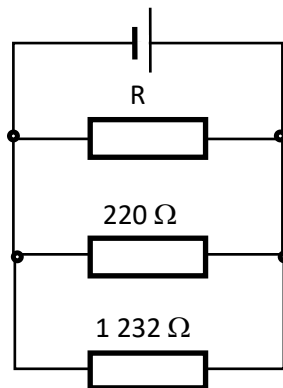

4. The total resistance of the following circuit is $112.5\ \Omega$. Calculate the resistance of resistor A.

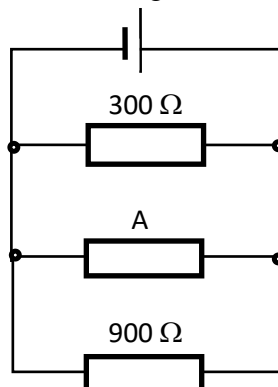

5. The total resistance of the following circuit is $240\ \Omega$. Calculate the resistance of resistor X

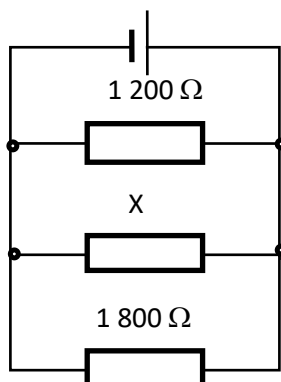

Combination Circuits

<i>Helpful Hint</i>			
R_s	=	$R_1 + R_2 + R_3 + \dots$	(for a series section of a circuit)
$\frac{1}{R_p}$	=	$\frac{1}{R_1} + \frac{1}{R_2} + \frac{1}{R_3} + \dots$	(for a parallel section of a circuit)

6. Calculate the total resistance in each of the following networks:

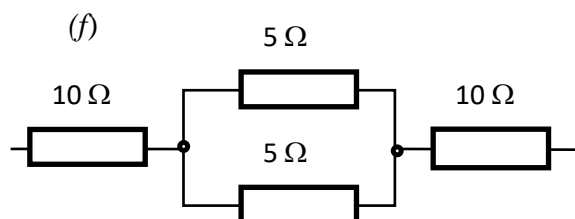
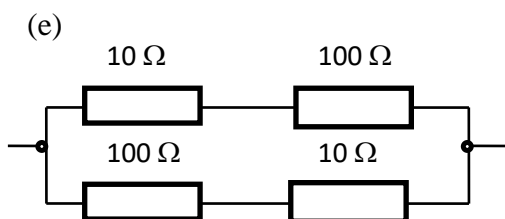
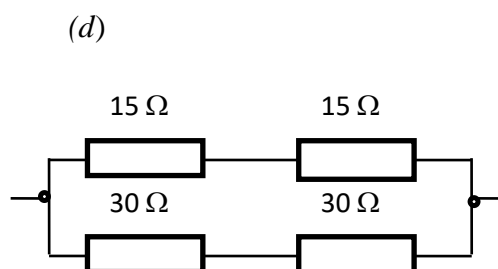
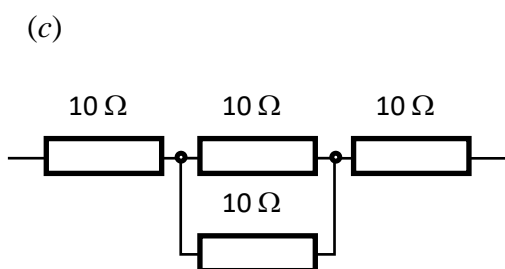
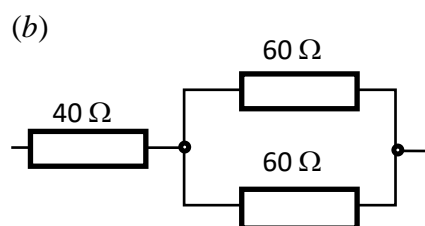
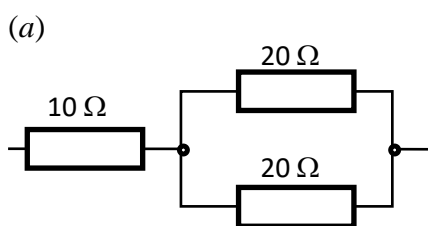

7. The following circuit shows part of a car lighting system.

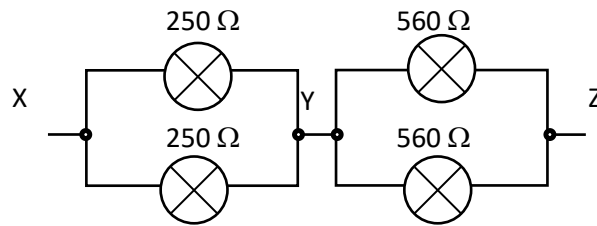

Calculate the resistance between points:

- (a) X and Y
- (b) Y and Z
- (c) X and Z.

8. Calculate the resistance of the network of resistors shown below.

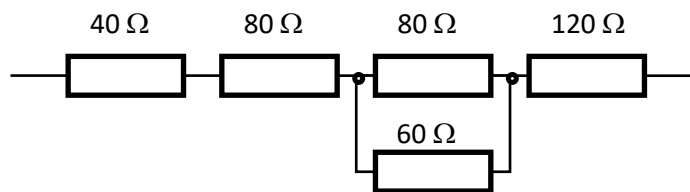

9. Which network of resistors has the lowest total resistance?

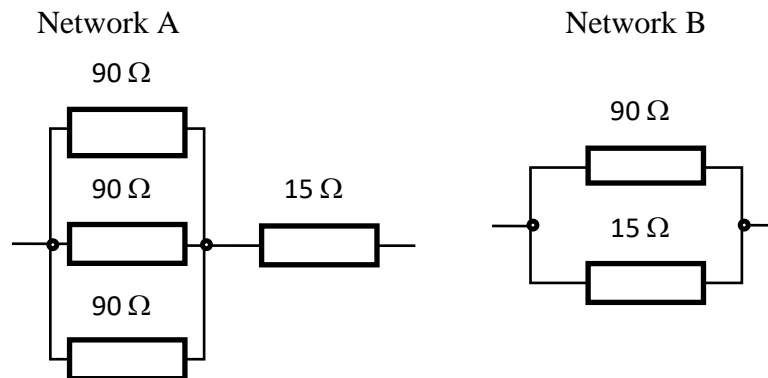

10. A school technician has different resistors to use in building house wiring models.

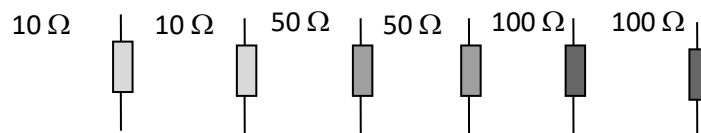

He has two $10\ \Omega$ resistors, two $50\ \Omega$ resistors and two $100\ \Omega$ resistors.
How can these resistors be combined to produce a total resistance of:

- (a) $260\ \Omega$
- (b) $300\ \Omega$
- (c) $30\ \Omega$
- (d) $35\ \Omega$?

12. Generation of Electricity

National 4

1. Select answers to the following clues from the list below:

Dynamo	Hydro Electric	Fossil Fuels	Wind
Solar Cells	Solar Panels	Wave Power	Turbine
	Magnet	Biogas	

- (a) This can be moved near a wire in order to generate electricity in the wire.
- (b) This device can be turned to convert movement energy into electrical energy?
- (c) Many people are having these installed on their roofs so they can make their own electricity.
- (d) Some calculators don't need batteries because they have these.
- (e) Coal, oil and gas are formed from animals and plants that lived millions of years ago. So what name is given to this group of fuels?
- (f) This renewable fuel is made by breaking down organic matter – like sewage!
- (g) In many power stations, this device spins around to turn magnets.
- (h) Scotland is ideal for this type of power station as it is hilly with high rainfall.
- (i) It is difficult to build this type of power station because of the stormy environment.
- (k) This is a great source of movement energy to turn certain turbines.
2. Copy and complete the following table to show some advantages and disadvantages of the energy sources listed.

Electricity Generation Method	Advantage	Disadvantage
Hydro Electric Scheme		
Coal Burning Power Station		
Nuclear Power Station		
Solar Fields		
Wind Turbines		

3.
 - (a) Explain why it is important to conserve energy.
 - (b) State three ways that you can do this.

4. Many people object to large pylons carrying electrical cables around the country because they say it spoils the scenery. One solution would be to bury the cables underground. Give reasons why this solution would be difficult to put in place.

5. **Read the following information and answer the questions below:**

Electrical energy is lost as electricity is transmitted through power lines as the cables heat up. The greater the distance we need to send the energy, the greater the energy loss each second. Also, the higher the current in a cable, the higher the energy loss each second.

Using a **transformer** we can increase the voltage from the power station to 400 000V for the cables in the “super grid”. By using a higher voltage to transfer the electrical energy in cables we can make the current very small and so lose less energy as heat. Electricity pylons carry the electricity high above us as the high voltages used are very dangerous.

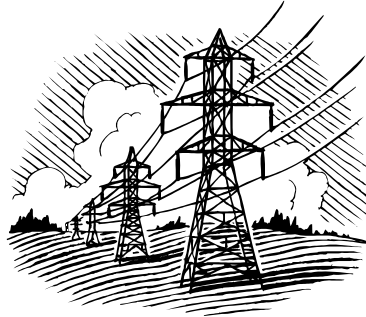

Questions

- (a) When current flows through wires or cables, what type of wasteful energy is created?
 - (b) In order to reduce energy losses in cables, should the current flowing be low or high?
 - (c) In order to reduce energy losses in cables, should the voltage across the cables be low or high?
 - (d) What is the name of the device that can change the size of an electrical voltage?
 - (e) At what voltage does electricity flow in the “super grid” cables?

6. In 2009 an average citizen in Iceland used 5837 W of electrical power while a person living in Ethiopia used 4 W. Approximately how many people from Ethiopia together consumed the same amount of energy as 1 person from the Iceland in 2009?

13. Electrical Power

Power, Energy and Time

National 4 and 5

In this section you can use the equation:

$$\text{power} = \frac{\text{energy}}{\text{time}}$$

also written as

$$P = \frac{E}{t}$$

where **P** = power in watts (W)
E = energy in joules (J)
t = time in seconds (s).

1. Find the missing values in the following table.

	Power (W)	Energy (J)	Time (s)
(a)		1 500	30
(b)		180 000	36 000
(c)	100		600
(d)	1 200		2
(e)	3 000	120 000	
(f)	2.5	25	

2. How long will it take for a 60 W bulb to use 720 J of electrical energy?

3. A bulb uses 45 000 J of energy in 300 seconds.
What is its power rating?



4. A 50 W immersion heater is switched on for 80 seconds. How much electrical energy passes through it in this time?

- 5.

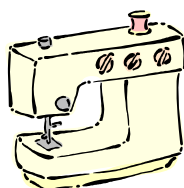

Calculate the power rating of an electric sewing machine which uses 4 560 J of energy in 8 minutes.

6. A 1 200 W hairdryer is switched on for 20 minutes. How much electrical energy does it use?
7. For how many minutes must a 600 W shaver be switched on in order to use 540 000 J of electrical energy?
8. An electric fire uses 5.22 MJ of electrical energy in half an hour. Calculate the power rating of the fire. (1 MJ = 1×10^6 J = 1 000 000 J)
9. How long will it take a 1.4 kW paint stripper to use 1.68 MJ of electrical energy?
10. A microwave oven is on for twenty minutes each day. If it uses 7.98 MJ of electrical energy in one week, what is its power rating?

Power, Current and Voltage

National 5

In this section you can use the equation:

$$\text{power} = \text{current} \times \text{voltage}$$

also written as

$$P = IV$$

where: **P** = power in watts (W)
I = current in amps (A)
V = voltage in volts (V).

Helpful Hint

The voltage of the **mains** is **230 V ac**.

1. Find the missing values in the following table.

	<i>Power (W)</i>	<i>Current (A)</i>	<i>Voltage (V)</i>
(a)		2.5	12
(b)		0.6	9
(c)	1.5×10^3		230
(d)	36		12
(e)	0.624	2.6×10^{-3}	
(f)	1.5	0.25	

2. A car battery supplies a voltage of 12 V. One headlamp bulb draws a current of 3 A. What is the power rating of this bulb?

- 3.



An electric shower has a power rating of 12 W and draws a current of 0.11 A. What voltage is required to operate the shower?

4. What current flows through a 230 V, 60 W household lamp when it is operating at the correct voltage?
5. Calculate the power rating of an electric drill which draws a current of 3 A when connected to the mains.

6. What would be the reading on the ammeter in the circuit shown?

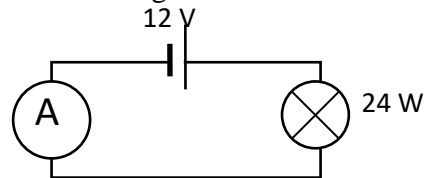

7. The following information was found on the rating plate of a food processor:

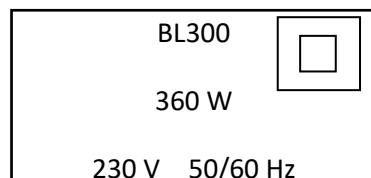

Calculate the current flowing in the food processor.

8. A fridge has a power rating of 160 W. When it is plugged into the mains what current will it draw?
9. A radio has a power rating of 6 W and draws a current of 0.5 A when operating normally.
 - (a) What voltage does this radio require?
 - (b) How many 1.5 V batteries would be needed to operate the radio?

10. The circuit shows a 1 kW heating element operating correctly.

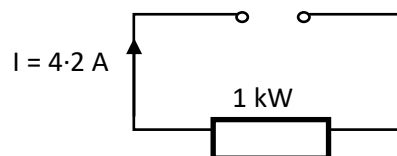

What is the voltage of the supply?

11. A torch bulb draws a current of 500 mA. It has a power rating of 1.75 W. What voltage is required to light the bulb to its correct brightness?

12. An electric locomotive on the East Coast line gets its electricity from the overhead cables which supply 25 kV a.c. The locomotive has a top speed of 140 mph and it operates at 4.7 MW. Calculate the current flowing to the locomotive.

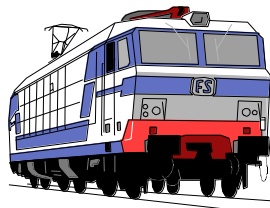

13. A helium - neon laser emits red light and has many uses in medicine. The laser uses the 230 V mains supply and has a power rating of 5 mW. What current flows in the laser?
14. The current flowing in an electric keyboard is measured as 800 mA. What voltage is required to operate the keyboard if it has a power rating of 7.2 W?
15. An electric fire has three heating elements which can be switched on and off independently. Each element has a power of 1.3 kW and is controlled by a switch on the side of the fire.
- (a) Calculate the current drawn from the socket when one heating element is switched on.
 - (b) What is the maximum current that the fire could draw?

Power and Resistance

National 5

Helpful Hint

By combining the formulae:

$$P = IV \quad \text{and} \quad V = IR$$

we have alternative forms of the formula for power.

i.e. $P = I (IR)$ and $P = (V/R) V$

$$P = I^2 R \qquad \qquad \qquad P = V^2/R$$

1.



Calculate the power rating of a lawn mower which has a resistance of $70.5 \, \Omega$ and draws a current of 2.5 amps.

2. What power is dissipated in the element of a toaster if it has a resistance of $64 \, \Omega$ and draws a current of 3.75 amps?
3. Find the power rating of a television given that it operates at mains voltage and has a resistance of $480 \, \Omega$.
4. What would be the power rating of an iron if it operates at mains voltage and has a resistance of $45 \, \Omega$?

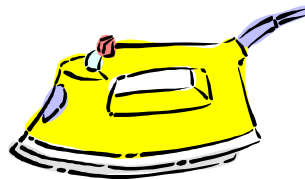

5. Calculate the power rating of a hedge trimmer given that it draws a current of $1.67 \, A$ and has a resistance of $144 \, \Omega$.
6. Calculate the power rating of a Karaoke machine if it has a resistance of $5\,760 \, \Omega$ and operates at mains voltage.
7. How much power is dissipated in curling tongs if they draw a current of $1.05 \, A$ and have a resistance of $230 \, \Omega$ while operating from the mains?

8. A microwave oven has a resistance of 68Ω and works properly from a mains supply. What is the power rating for such an oven?

9.



Find the power rating of a Hoover designed with a resistance of 110Ω when operating at mains voltage.

10. What current is drawn from the supply by a transistor radio if it has a power rating of 3 W and a resistance of 12Ω ?
11. Find the resistance of a table lamp which has a power rating of 115 W and draws a current of 0.5 A .
12. An alarm clock is driven by a domestic supply voltage of 230 V . What is its resistance if it has a power rating of 2 W ?
13. Calculate the total resistance of an electric fire if it operates safely at 230 V and uses electrical energy at a rate of 750 W .
14. Calculate the voltage of a car alarm which has a power rating of 3 W and resistance of 50Ω .
15. Find the power rating of an electric food mixer if it operates at mains voltage and has a resistance of 400Ω .

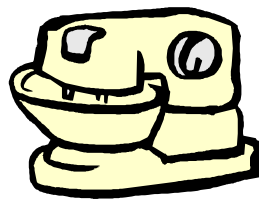

14. Miscellaneous Questions on Circuits

1. The following circuit is set up in a laboratory.

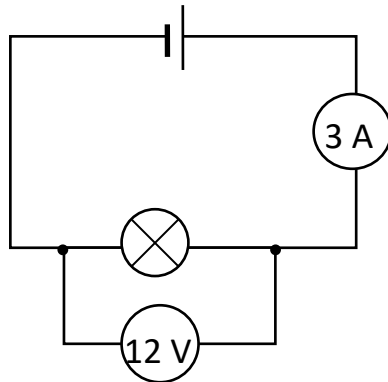

The bulb is switched on for 3 minutes and the voltmeter and ammeter readings remain as shown in the diagram.

- Calculate the power rating of the bulb.
 - Calculate the resistance of the bulb.
 - Calculate how much electrical energy is supplied to the bulb in the 3 minutes.
 - Calculate how much charge passes through the bulb in the 3 minutes.
2. The resistor in the following circuit has a power rating of 0.09 W .

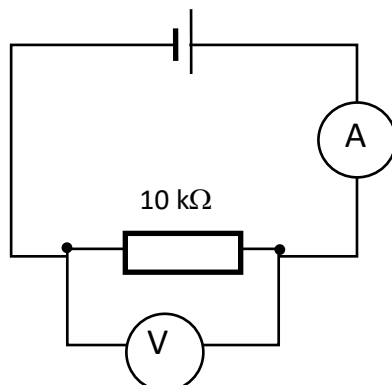

- What reading would you expect to find on the ammeter?
- What reading would you expect to find on the voltmeter?
- How long would it take for 5.4 joules of electrical energy to be supplied to the resistor?
- How much charge passes through the resistor in 1 minute?

3. Some students decide to measure the resistance of a torch bulb and each set up a circuit to do this. The circuits are shown below.

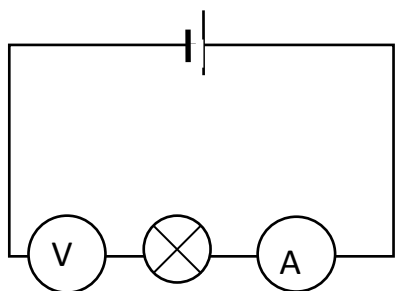

Circuit 1

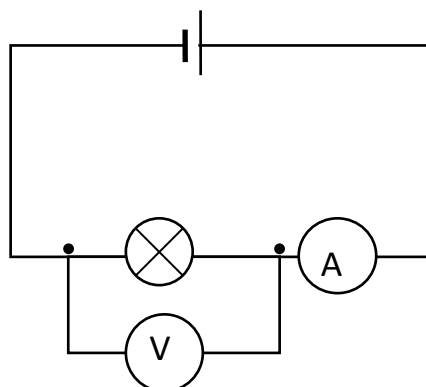

Circuit 2

- (a) Which circuit has been set up correctly? Explain your answer.
- (b) Use the following results to plot a graph of voltage against current and hence or otherwise find the resistance of the torch bulb.

<i>Current (A)</i>	<i>Voltage (V)</i>
0.5	5
0.8	8
1.1	11
1.4	14
1.7	17

4. The rating plate on an electric kettle is shown below.

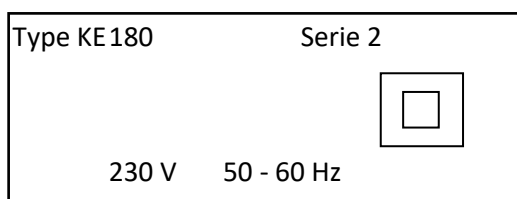

- (a) Calculate the current flowing in the kettle.
- (b) What is the resistance of the heating element in the kettle?

5. A vacuum cleaner connected to the mains draws a current of 3.1 A .
- What is the power rating of the vacuum cleaner?
 - What is the resistance of this appliance?
6. An iron rated at 1.1 kW draws a current of 4.6 A . One day $8\,280\text{ C}$ of charge passed through the iron.
- How long was the iron in use?
 - How much electrical energy was supplied in this time?
7. A bulb in a laboratory operates with a current of 2 A . During an experiment $1\,200\text{ C}$ of charge flow through the bulb, supplying it with $14\,400\text{ J}$ of electrical energy.
- How long did this experiment last?
 - What was the power rating of the bulb?
8. The power rating of an electric fire is 3 kW and it draws a current of 12.5 A . One afternoon the fire used up 8.1 MJ of electrical energy.
- For how long was the fire switched on?
 - How much charge passed through the fire in this time?
9. An electrical appliance has a power rating of 2.4 kW . If $432\,000\text{ J}$ of electrical energy are supplied to the appliance by $1\,800\text{ C}$ of charge, calculate the current drawn by the appliance.
10. The following label is attached to a hairdryer.

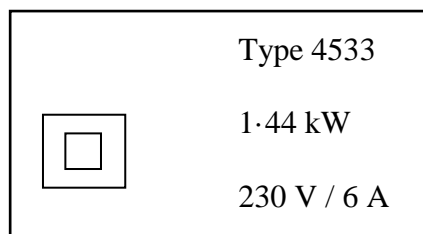

Calculate the amount of electrical energy supplied to the hairdryer by $4\,320\text{ C}$ of charge.

11. Bulbs B_1 , B_2 and B_3 are all identical. What is the voltage across bulb B_2 and bulb B_3 ?

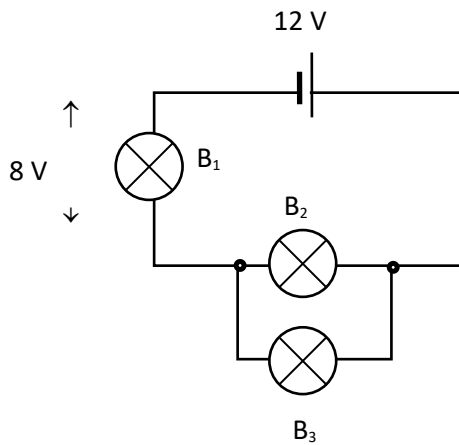

12. Look at the circuit shown and find:

- (a) the voltage across R_2
 (b) the current through R_1 .

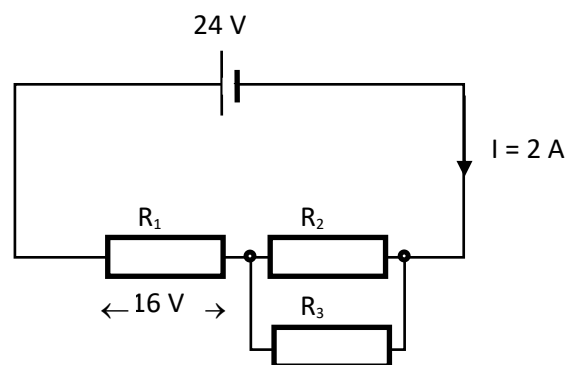

13. In the following circuit the bulbs are identical. Find:

- (a) the voltage across each bulb
 (b) the current through each bulb.

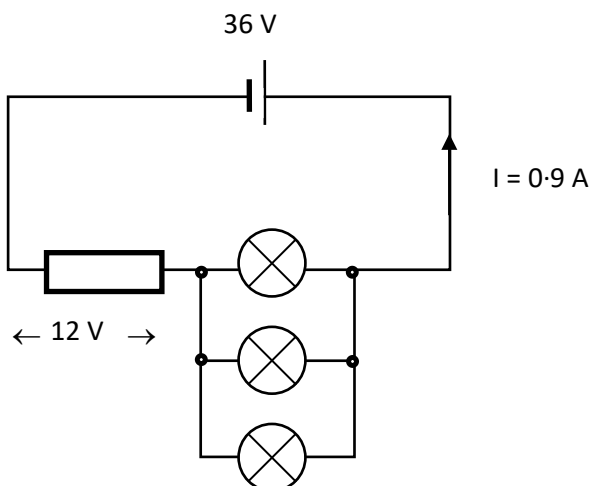

14. In the following circuit all the resistors are identical. Find:

- (a) the voltage across each resistor
- (b) the current through each resistor.

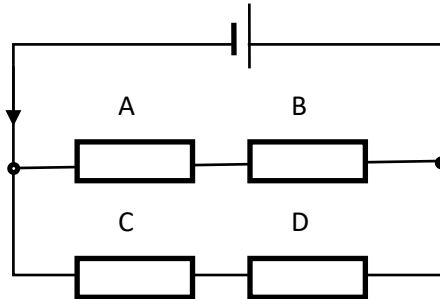

15. Daral has a selection of resistors and has to combine them in some way to obtain a total resistance of 60Ω .

He has two 5Ω , two 20Ω and two 90Ω resistors.

He sets up three different networks as shown below. Which one is correct?

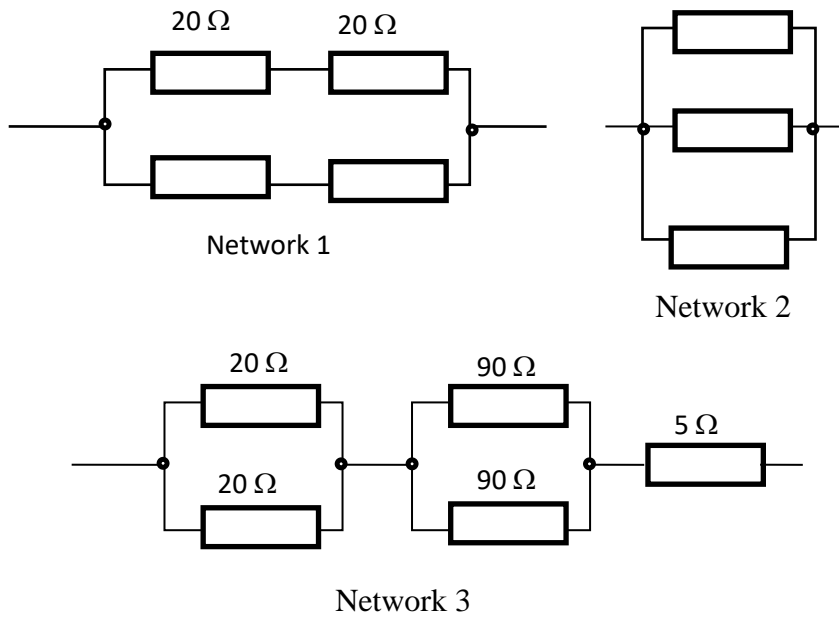

15. Energy Transformations

National 5

In this section you can use the following equations:

$$E = P t$$

$$E_p = m g h$$

$$P = I V$$

where	E	=	energy in joules (J)
	I	=	current in amps (A)
	t	=	time in seconds (s)
	E_p	=	gravitational potential energy in joules (J)
	m	=	mass in kilograms (kg)
	g	=	gravitational field strength in newtons per kilogram (Nkg ⁻¹)
	h	=	height in metres (m)
	P	=	power in watts (W)
	V	=	voltage in volts (V)

Helpful Hint

Energy cannot be created or destroyed only changed from one form to another. In a pumped storage hydroelectric power station, the potential energy of the water is converted to electrical energy when the water **falls** from the reservoir into the turbines attached to the generator. At night when the water is pumped back **up** to the reservoir electrical energy in the pump is converted into potential energy.

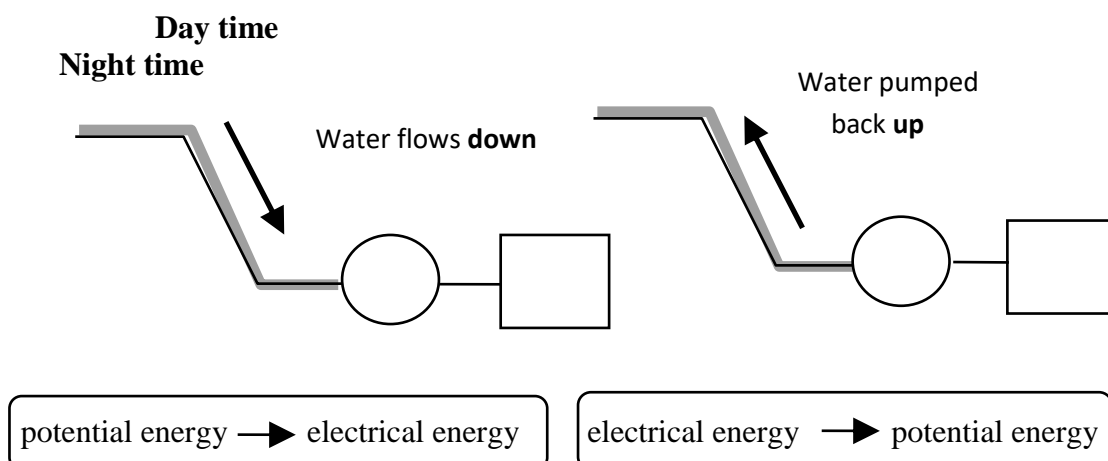

Often in these questions you will be given the **rate** of flow of water i.e. how many kilograms flow each second. This gives you **two** pieces of information, **mass** and **time**.

1. How much potential energy could be converted into electrical energy when 200 kg of water falls 40 m into a turbine attached to a generator?
2. How much energy is stored in a pumped storage hydroelectric scheme if 6 000 kg of water is pumped up 210 m to a reservoir at night time when there is a surplus of electricity?
3. In a hydroelectric power station 400 kg of water flow each second through the turbines of the power station from a loch 200 m above the turbines.
 - (a) How much potential energy is lost by the water each second?
 - (b) How much electrical energy could be generated each second assuming that there are no energy losses?
 - (c) What would the output power of this station be?
4. A small reservoir is situated 120 m above a hydroelectric power station. The station gives an output power of 2.25 MW.
 - (a) How much electrical energy is generated each second in this power station?
 - (b) How much potential energy must the water flowing into the turbines lose each second in order to generate this electricity?
 - (c) What mass of water must flow each second through the turbines of the power station in order to generate 2.25 MW of electricity?
5. The generator of a hydroelectric power station produces an output power of 1.1 MW. Water flows at a rate of 300 kg per second from the loch above the power station.
 - (a) How much electrical energy is generated each second?
 - (b) How much potential energy must be converted into electrical energy each second?
 - (c) How high is this loch?

6. (a) How much energy is stored in the reservoir of this hydroelectric scheme if it contains 200 000 kg of water?

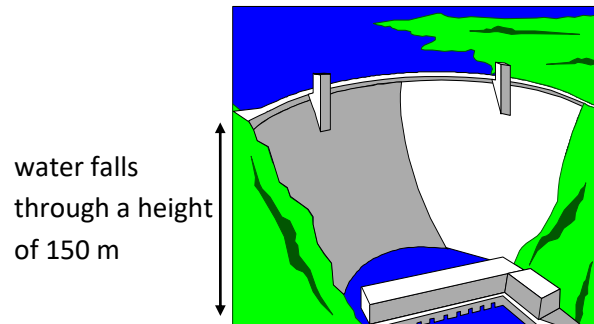

- (b) If all this water flows into the turbines attached to the generators in 1 hour what would the output power from this station be?
7. 2.4×10^6 kg of water flow from a loch 150 m high in 8 hours. What power could this water generate in a hydroelectric power station?
8. An electric pump is required to fill a reservoir with 1.6×10^6 kg of water in 6 hours. The reservoir is 40 m above the pump house.
- (a) How much potential energy must the water gain in 6 hours?
- (b) How much electrical energy must the pump receive in the 6 hours?
- (c) Calculate the power of the pump.
9. In a model pumped storage hydroelectric power station an electric pump is used to lift water through a height of 1 m. The pump is connected to a 12 V supply and draws a current of 2 A.
- (a) How much electrical energy does the pump use each second?
- (b) How much potential energy could this pump give to the water each second?
- (c) What mass of water can the pump lift each second?
10. A 230 V pump drawing a current of 3 A is required to lift 200 kg of water through a height of 7 m .
- (a) How much potential energy will the water gain?
- (b) How much electrical energy must be provided to the pump?
- (c) How long will it take for the pump to lift all the water?

Helpful Hint

The energy required to heat materials is often produced by an electrical heater.

Substituting $P = IV$ into $E = Pt$ gives $E = ItV$

where E = energy in joules (J)
 P = power in watts (W)
 t = time in seconds (s)
 I = current in amps (A)
 V = voltage in volts (V)

You can also use the principle of conservation of energy to solve problems where an electrical heater is used. You studied the “Heat” equations in the previous unit, “Dynamics & Space”:

$$E_h = Pt = cm\Delta T$$

$$E_h = Pt = mL$$

$$E_h = ItV = cm\Delta T$$

$$E_h = ItV = mL$$

Use the principle of conservation of energy to solve the following:

11. How long would it take a 50 W immersion heater to heat 2 kg of water from 10 °C to 80 °C?
12. How long would it take for a 2 kW kettle to heat 800 g of water from 40 °C to 100 °C?
13. A 100 W heater is used to heat a 4 kg block of lead. If the heater is left on for 10 minutes calculate the rise in temperature of the block of lead.
14. Calculate the power of an immersion heater which takes 20 minutes to heat 4 kg of water by 60 °C.
15. An electric heater operates at 12 V and takes a current of 3 A. It is used to boil alcohol. Calculate the mass of alcohol the heater could evaporate in 20 minutes.
16. A kettle operating at mains voltage draws a current of 9.6 A. This kettle evaporated 290 g of water at 100 °C in a time of 5 minutes. What value does this give for the specific latent heat of vaporisation of water?
17. 600 g of water was supplied with 163 020 J of heat. Energy losses were negligible.
 - (a) What was the change in temperature of the water?
 - (b) If heat was supplied to the water at a rate of 543.4 joules per second, how long did it take to heat the water?

18. The temperature of 2 kg of steel is raised by 10 °C. It takes 3 minutes for an electric heater connected to the mains (230 V) to do this.

- (a) What is the minimum energy supplied to the steel?
- (b) Assuming no energy losses, what is the power rating of the heater?
- (c) What current is drawn by the heater?

19. A 500 g mass of copper is heated by a 40 W immersion heater while a 500 g mass of steel is heated by a 50 W heater. The initial temperature of each block is 20 °C. Which block is the first to reach a temperature of 80 °C? You can assume that there are no energy losses.

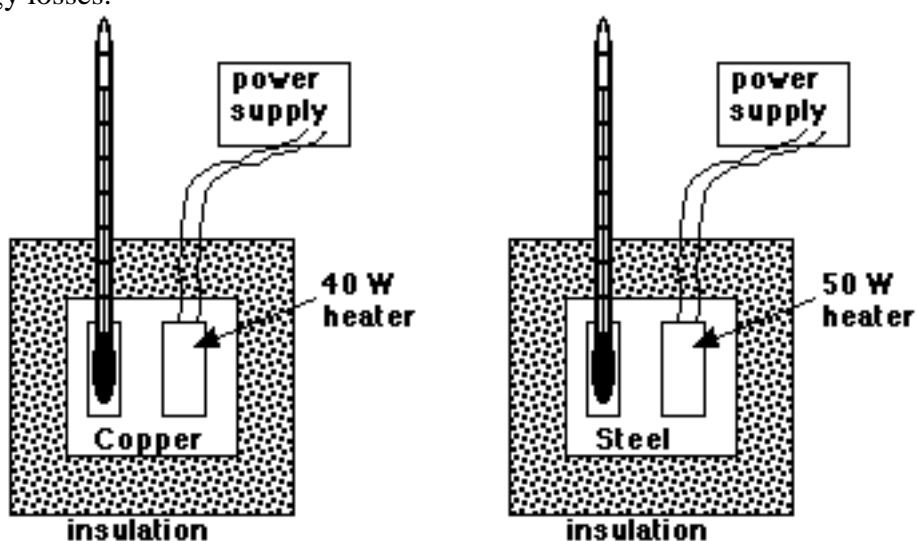

20. 80 g of alcohol at 20 °C is heated by an electric heater for 6 minutes until it reaches its boiling point of 65 °C. The heater operates at 230 V and draws a current of 125 mA.

- (a) How much electrical energy is used by the heater?
- (b) How much heat energy is absorbed by the alcohol?
- (c) How much energy was 'lost' to the environment?

16. Efficiency

National 4

In this section you can use the following two equations:

$$\text{efficiency} = \frac{\text{useful energy out}}{\text{useful energy in}}$$

$$\text{efficiency} = \frac{\text{useful power out}}{\text{useful power in}}$$

Helpful Hint

Efficiency is usually expressed as a percentage and you should change percentages to decimals before using this equation.

Example 1

A generator in a thermal power station converts 1 000 J of kinetic energy into 800 J of electrical energy. What is the efficiency of the generator?

$$\text{efficiency} = \frac{\text{useful energy out}}{\text{useful energy in}} = \frac{800}{1000} = 0.8 = \mathbf{80\%}$$

Example 2

A motor is 65 % efficient. What power can this motor deliver when it receives 2 000 W?

$$65 \% = 0.65 = \frac{\text{useful power out}}{2\,000}$$

$$\text{useful power out} = 0.65 \times 2\,000 = \mathbf{1\,300\ W}$$

1. Find the missing values in the following table.

	<i>Efficiency (%)</i>	<i>Useful energy in(J)</i>	<i>Useful energy out(J)</i>
(a)		1 400	700
(b)		675	135
(c)	80	1 200	
(d)	45		1 500
(e)	60	300	
(f)	25		6 000

2. A coal fired power station has a power output of 200 MW. The power produced by the boiler is 340 MW. Calculate the efficiency of the power station.

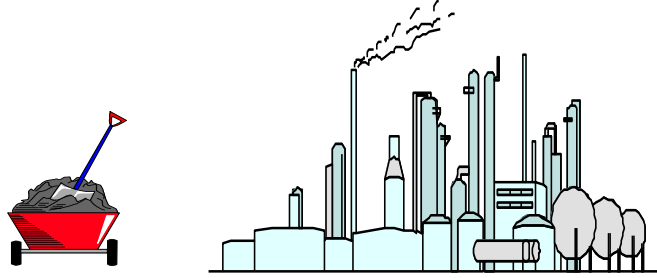

3. A turbine converts 65 000 J of heat energy into 13 000 J of kinetic energy. What is the efficiency of the turbine?
4. A generator converts 3 156 MJ of kinetic energy into 450 MJ of electrical energy. What is the efficiency of the generator?
5. A thermal power station converts 420 MJ of chemical energy into 124 MJ of electrical energy. What is the efficiency of this power station?
6. An electrical pump used in a pumped storage hydroelectric power station is 80 % efficient. How much work can the pump do if it is supplied with 25 kJ of energy each second?
7. An oil fired power station which is 40% efficient produces an output of 300 MW. How much power must be supplied to the station to produce this output?
8. The output from an oil-fired power station is 250 MW and it is 32 % efficient. How much power must be provided by the oil to produce this output?
9. The Glenlee hydroelectric power station produces 24 000 kW of electricity. How much power is provided by water falling from the reservoir if the station is 25 % efficient?
10. The boiler of a thermal power station releases 2.8×10^8 J of heat energy for each kilogram of coal burned. The generator of the power station produces 1.26×10^8 J of electrical energy for each kilogram of coal burned. What is the efficiency of this power station?

11. The tidal power station at the Rance in Brittany, France opened in 1966. Each of the 24 turbines can generate an output of up to 10 MW from the tidal currents funnelled into the river estuary. Assuming that each turbine is 45 % efficient calculate the power of the tide required to generate 10 MW at one turbine.
12. Water flowing into the turbines of a hydroelectric power station loses 4.5×10^6 J of potential energy each second. How much electrical energy could this power station produce if it is 35 % efficient?
13. A house has solar panels covering an area of 10 m^2 to provide domestic hot water. The solar power received by each square metre is 180 W on a summer day and the panels are 20 % efficient. Calculate the heat energy that would be produced by the panels on such a day.
14. The average power in waves washing the north Atlantic coast of Europe is 50 kW per metre of wave front. What length of wave front would be required to generate 10 MW of electricity from these waves using a 45 % efficient wave - power device?
15. The 3 MW wind turbine at Burger Hill in Orkney provides energy for the national grid. If this turbine is 25 % efficient calculate how much energy is wasted each second in this system.

17. Electromagnetism

National 4

1. Magnetic fields exist around magnets and their effect can be shown by scattering iron filings around a magnet. The filings “line up”, to follow the magnetic field pattern, in lines. We say the direction of a magnetic field points from the NORTH pole to the SOUTH pole.

- (a) Copy the diagrams below and add lines with arrows to show the magnetic fields.



- (b) Beside each diagram in part (a), state whether the magnets will attract or repel each other.

2. An electromagnet can be made easily by coiling a wire around an iron nail as shown below. One way of testing the strength of the electromagnet is to find out how many paper clips it can pick up.

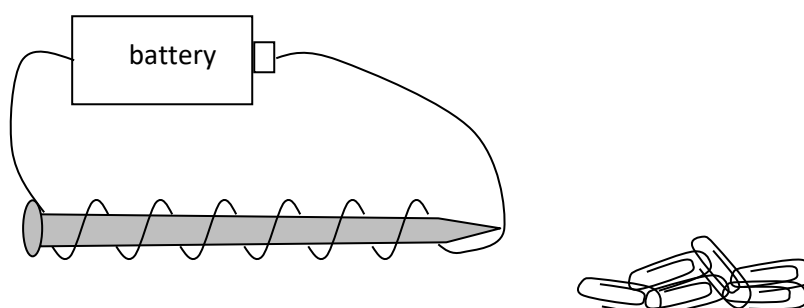

- (a) State one advantage of an electromagnet over a permanent magnet.
- (b) State two ways to make the magnet stronger.
- (c) State two uses of electromagnets.

3. A “relay switch” can be used to switch on high voltage circuits using a low voltage supply.

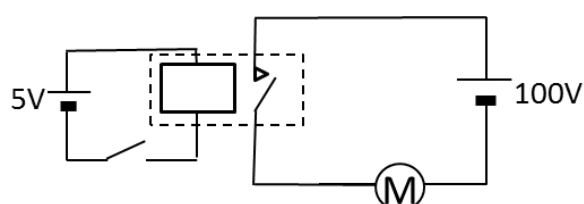

- (a) Describe how the relay switch works.
- (b) Why do you think it is safer to switch on the motor with a relay switch?

4. The graph below shows how the number of paper clips picked up by an electromagnet is affected by the number of times it is coiled around the iron nail.

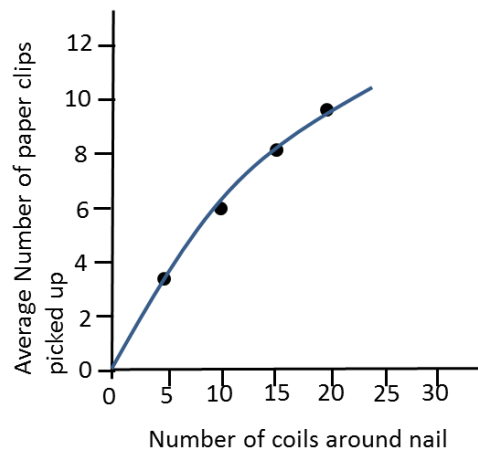

- (a) Use the graph to determine the average number of paper clips that were picked up when 10 coils were wrapped around the nail.
- (b) Suggest how many coils should be wrapped around the nail in order to pick up 5 paper clips.
- (c) Predict how many paper clips would be picked up when 30 coils are wrapped around the nail.
5. A basic design for an electric bell is shown below.

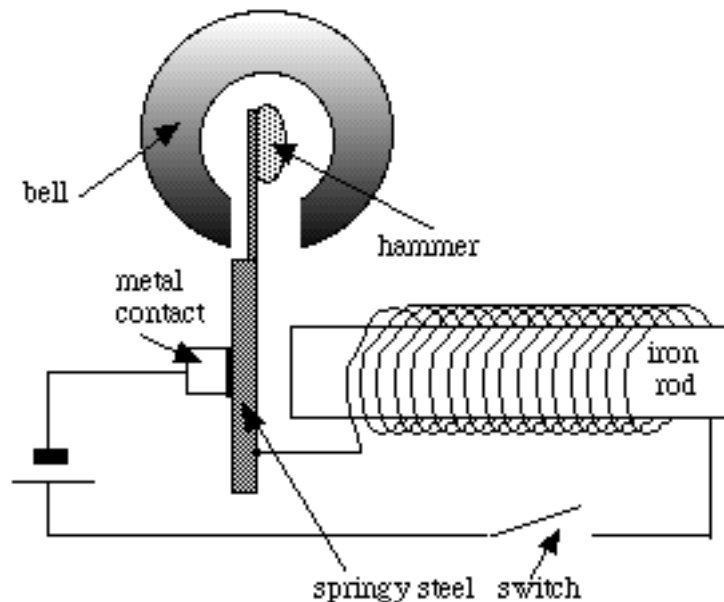

Explain how the bell operates.

18. Electronic Systems – Output Devices

National 4 and 5

- Which of the components in the list below are output devices?

bulb	thermistor	relay	thermocouple
solenoid	loudspeaker	dynamo	LED
LDR	buzzer	motor	microphone
- Which output device could be used in a central locking system of a car?
- What would be an appropriate output device for a public address system?
- Select an output device which could be used to raise and lower blinds automatically in a luxury flat.
- Which output device is useful for digital displays on hi-fi systems?
- Draw the symbol for each of the output devices you identified in question 1.

19. L.E.D Circuits

National 5

1. Which of the following LED's will light?

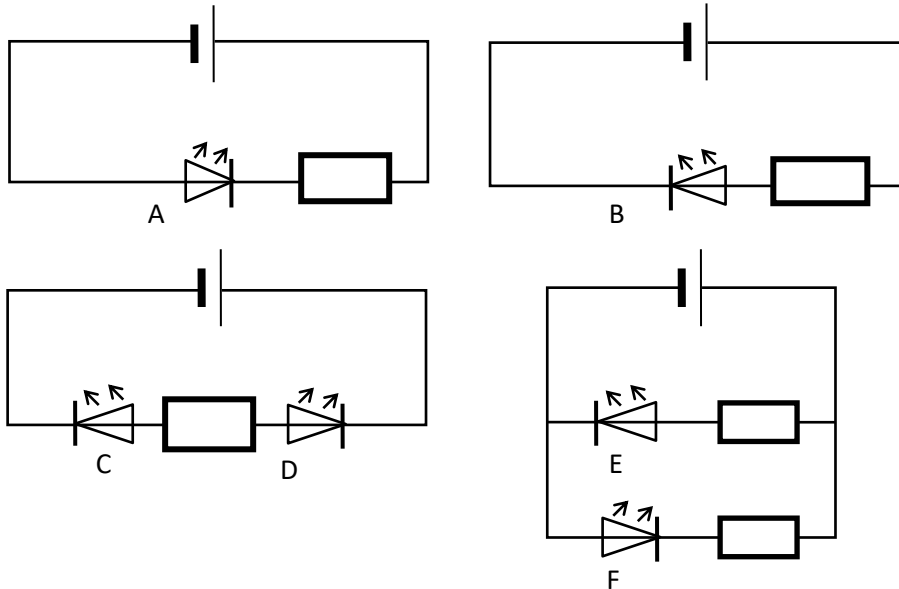

Helpful Hint

When working with LED circuits you can use the equation:

$$V = IR$$

When applying this equation remember that the **supply voltage is shared** between the LED and the resistor.

Example

A certain LED takes a current of 10 mA and it requires a voltage of 2 V. What should be the value of the series resistor when a supply voltage of 5 V is used?

1st. Sketch the circuit

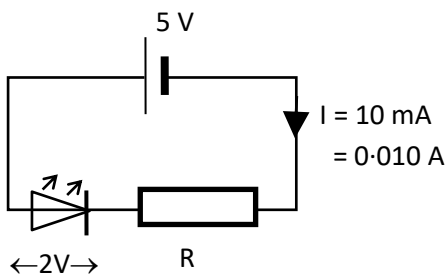

2nd. Calculate the voltage across resistor R.

$$\begin{aligned} V_R &= V_{\text{supply}} - V_{\text{led}} \\ &= 5 - 2 \\ &= \underline{3V} \end{aligned}$$

3rd. Apply $V = IR$ to find the value of R

$V_R = 3V$	$V_R = IR$
$I = 0.01A$	$3 = 0.01 \times R$
$R = ?$	$R = 3 / 0.01$
	$R = \underline{300\Omega}$

2. Use the stages outlined on the previous page to find the missing values in the following table.

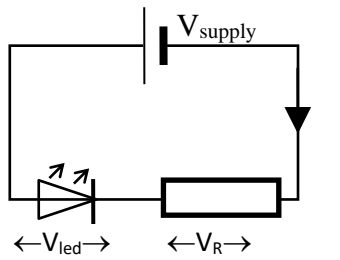

	V_{supply} (V)	Voltage across LED (V)	Current (A)	Voltage across R (V)	Resistance of R (Ω)
(a)	6	2.0	0.010		
(b)	12	2.0	0.010		
(c)	8	1.8	0.016		
(d)	20	1.6	0.008		
(e)	4	1.5	0.020		
(f)	11	2.0	0.012		

3. For each of the following circuits calculate the value of the series resistor which will enable the LED to operate at its ideal voltage and current.

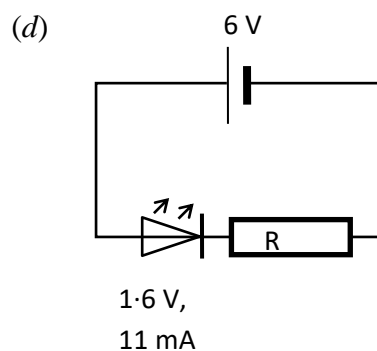
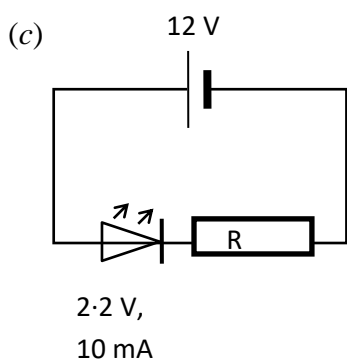
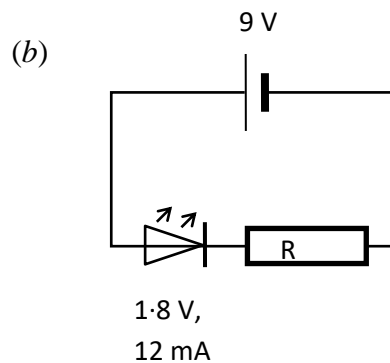
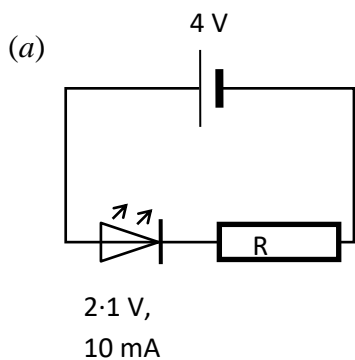

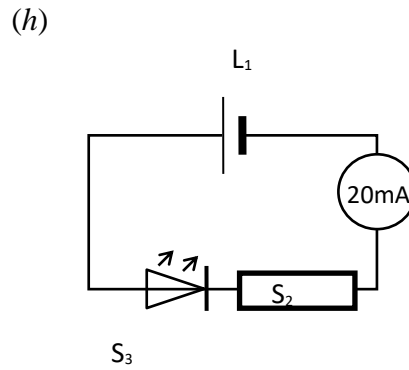
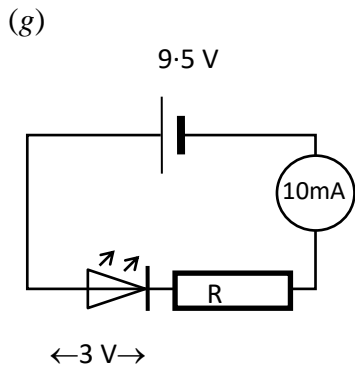
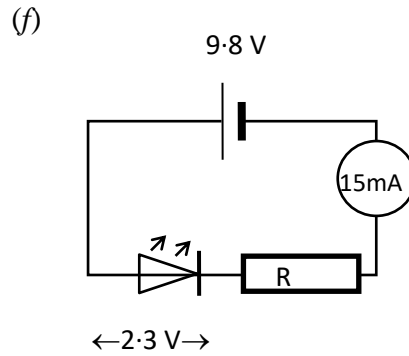
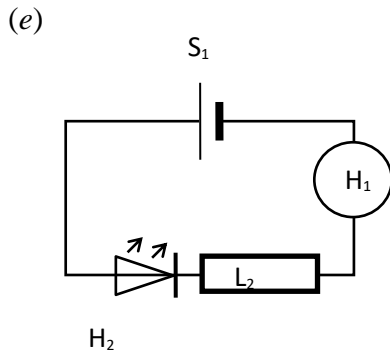

4. Consider the following circuit.

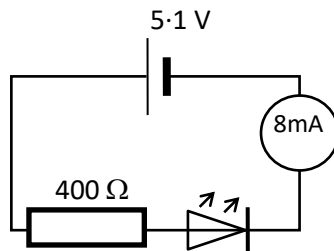

- Calculate the voltage across the $400\ \Omega$ resistor.
- Calculate the voltage across the LED.

5. For the circuit shown below work out the value of the supply voltage which will enable the LED to operate at its stated rating.

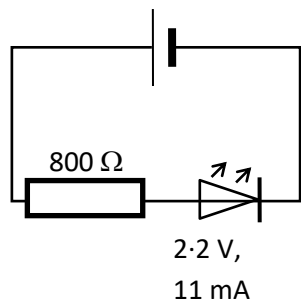

6. The voltage and current specifications for a certain LED are 1.75 V and 10 mA respectively. What should be the value of the series resistor if the LED is powered by a 6 V supply?

7. Calculate the ammeter reading in the following circuit.

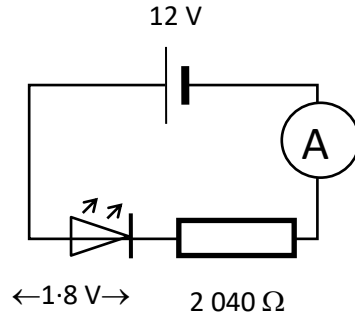

8. Calculate the voltmeter reading in the circuit shown below.

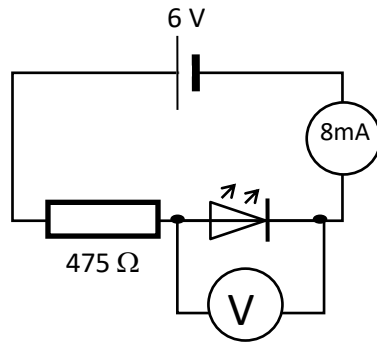

9. What is the supply voltage for the following circuit?

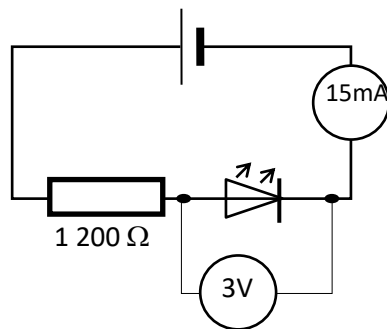

10. Calculate the value of resistor R in the circuit below.

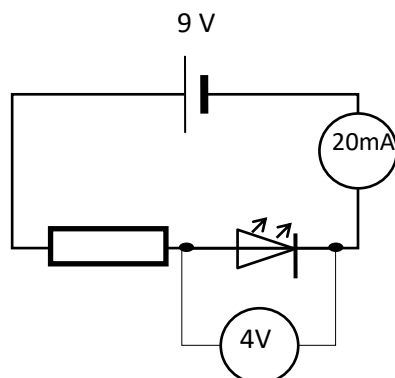

20. Electronic Systems – Input Devices

National 4 and 5

In this section you can use the equation:

$$V = IR$$

where V = voltage in volts (V)
 I = current in amps (A)
 R = resistance in ohms (Ω).

Helpful Hint

When choosing an input device for an electronic system, think about what type of energy the device has to detect.

capacitor

thermocouple

microphone

thermistor

photovoltaic cell

light dependent resistor (LDR)

1. Select from the list above a suitable input device for each of the following:

- (a) Public address system in a railway station
- (b) Digital thermometer
- (c) Photographers light meter
- (d) Time delay circuit for courtesy lights in a car
- (e) Pilot light flame detector in a gas central heating system
- (f) Sunlight hours recorder at a weather station.

2. The circuits below show two identical LDR's each connected to a 6 V supply. One LDR is placed in a cupboard and the other is placed beside a window.

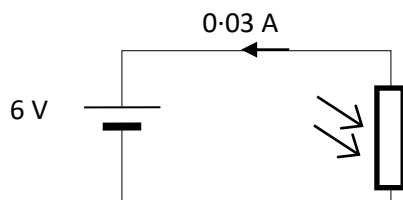

Circuit (i)

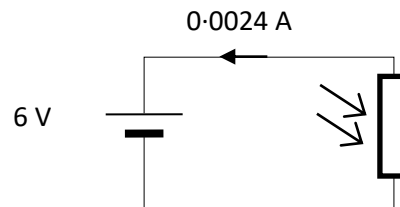

Circuit (ii)

- (a) Calculate the resistance of each LDR.
- (b) State which circuit shows the LDR in the cupboard.

3. The following circuit shows a thermistor connected to a 5 V supply and placed in a school laboratory.

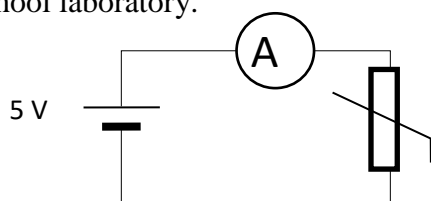

One morning the ammeter gave a reading of 1.25 mA. Later in the same day the reading had risen to 2.5 mA.

- Calculate the resistance of the thermistor in the morning.
 - State what happened to the temperature in the room during the day? Explain your answer.
4. The following information for an LDR was found in a components catalogue.

<i>Light Source</i>	<i>Illumination (lux)</i>	<i>Resistance (kΩ)</i>
moonlight	0.1	10 000
60 W bulb at 1m	50	2.4
fluorescent light	500	0.2
bright sunlight	30 000	0.02

This LDR is connected to a 12 V supply with an ammeter in series as shown in the diagram.

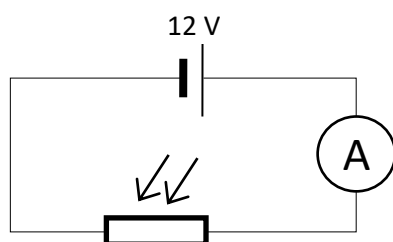

- Determine the resistance, in ohms, of the LDR when exposed to fluorescent light?
- Calculate the ammeter reading when a lamp with a 60 W bulb is placed 1 m away from the LDR?
- For one source, the ammeter gives a reading of 0.6 A. Determine which light source is being used.

5. A pupil uses a thermistor as a simple electronic thermometer. She connects the thermistor to an ammeter and places the thermistor into a beaker of hot water. The ammeter gives a reading of 8 mA.

<i>Temperature (°C)</i>	<i>Resistance (Ω)</i>
20	3 750
40	198
60	750
80	350
100	200

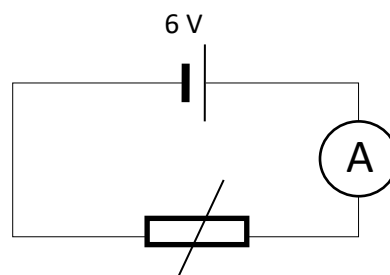

- (a) Determine the temperature of the water in the beaker?
- (b) The pupil adds some more water to the beaker and the ammeter gives a new reading of 1.6 mA. Determine whether the pupil added hot or cold water to the beaker.
- (c) Calculate the new temperature of the water.
- (d) Determine the ammeter reading when the water reaches boiling point.

21. Potential Divider Circuits

National 5 Extension

In a series circuit the supply voltage is **divided up** between the components in the circuit i.e.

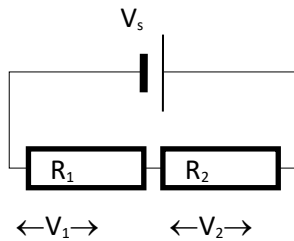

$$V_s = V_1 + V_2$$

where

V_s = supply voltage

V_1 = voltage across R_1

V_2 = voltage across R_2

From Ohm's law we know that since current is constant in a series circuit, the higher the resistance of a component the greater the potential difference across it.

This idea is used in the following example to calculate the potential difference across components in a 'potential divider' i.e. series circuit.

Example

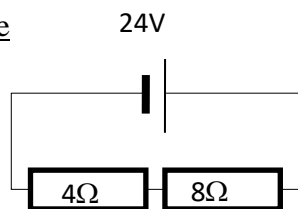

Use the fact that the voltage 'split' across each component is in the same ratio as the resistance of each component.

$$\begin{aligned}
 V_1 &= \frac{R_1}{R_t} \times V_s & V_2 &= \frac{R_2}{R_t} \times V_s & \text{where } R_t &= \text{total resistance} \\
 &= \frac{4}{12} \times 24 & &= \frac{8}{12} \times 24 & & \\
 &= 8V & &= 16V & &
 \end{aligned}$$

(Remember to check your answer e.g. does $V_1 + V_2 = V_s$)

Lastly!

Circuit problems in electronics are usually drawn slightly differently than you are used to seeing.

e.g.

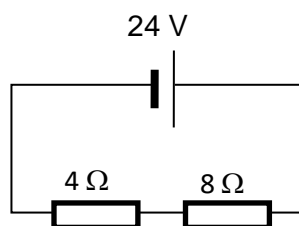

would be drawn as

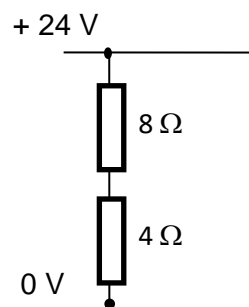

Find the potential difference across each resistor in the following circuits:

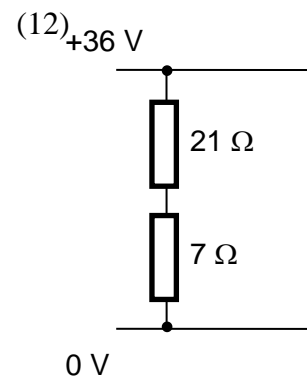
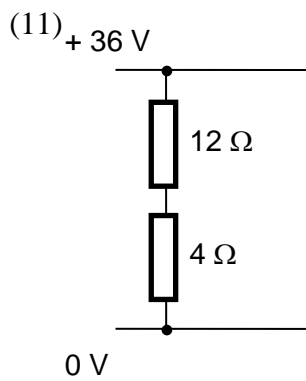
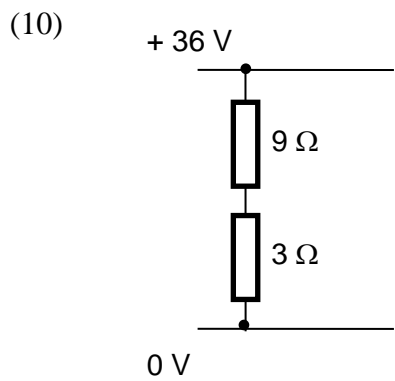
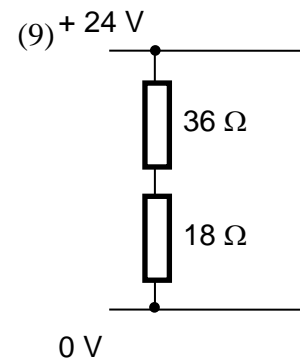
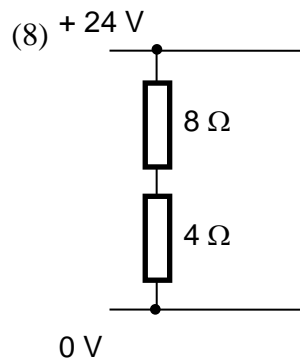
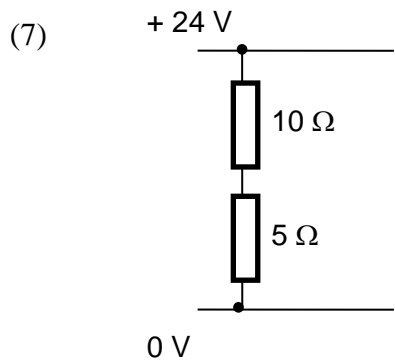
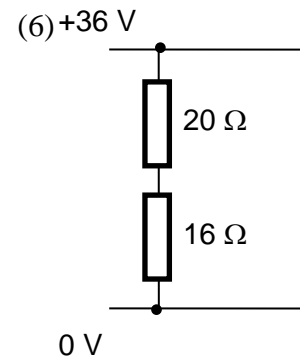
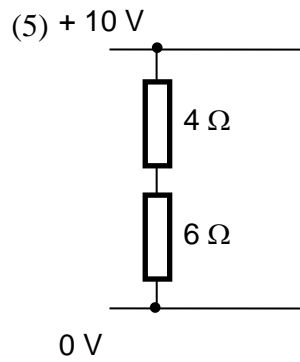
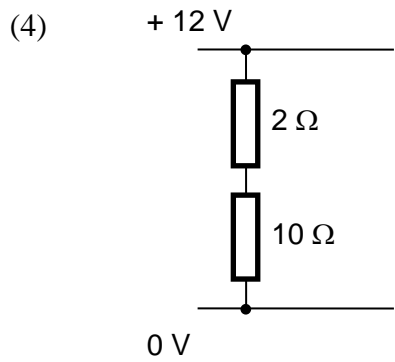
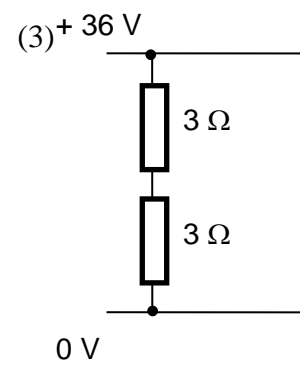
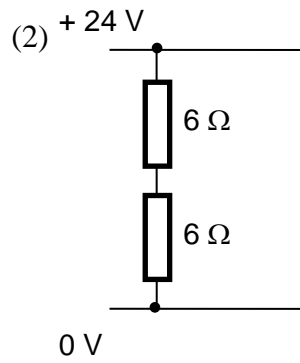
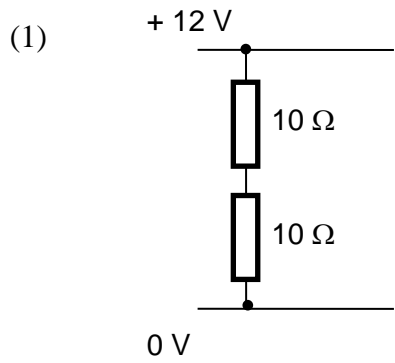

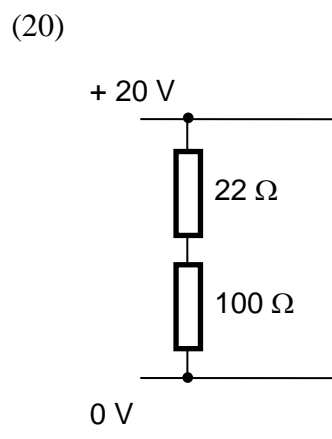
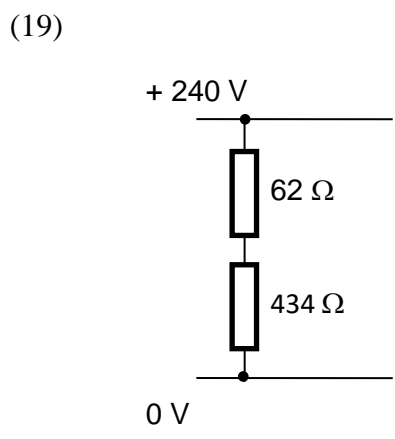
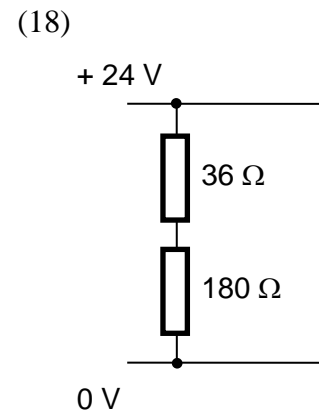
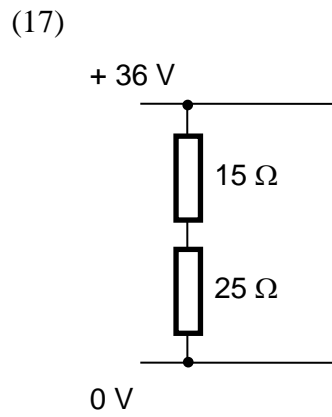
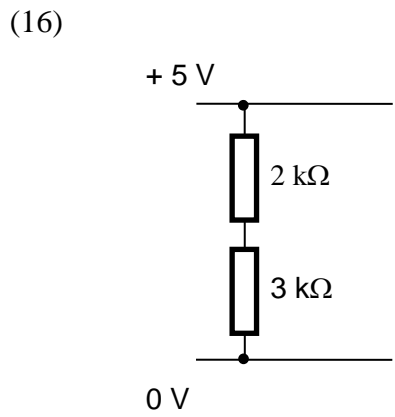
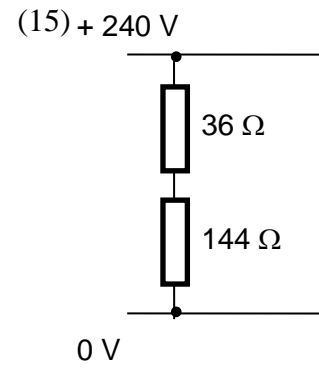
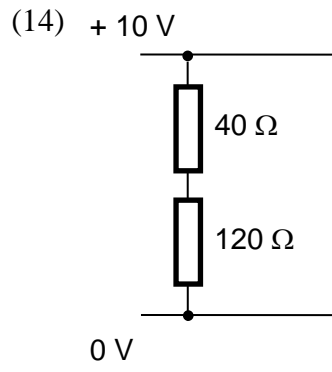
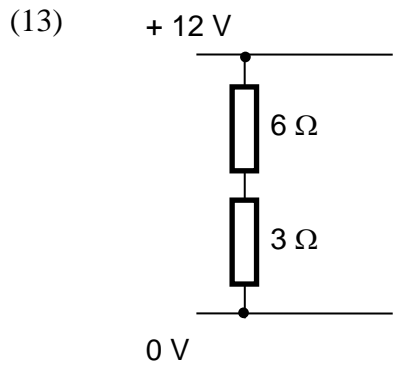

Helpful Hint

LDR's and thermistors often make up part of a potential divider circuit in electronic systems. It is important to remember that the **resistance** of these components varies with external conditions.

Use the following data to answer questions 21 – 25.

The tables below show how the resistances of a certain LDR and thermistor vary with external conditions.

LDR

<i>light condition</i>	<i>resistance (Ω)</i>
dark	10 000
light	2 500
bright	20

Thermistor

<i>temperature ($^{\circ}\text{C}$)</i>	<i>resistance (Ω)</i>
10	4 000
40	1 980
100	200

21. The following circuit is part of the input to an electronic frost alarm.

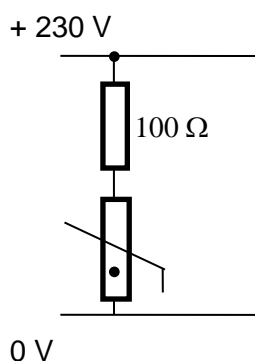

Calculate the potential difference across the thermistor when it is

- (a) 10°C
- (b) 40°C

22. The following circuit could be part of a light meter for a camera.

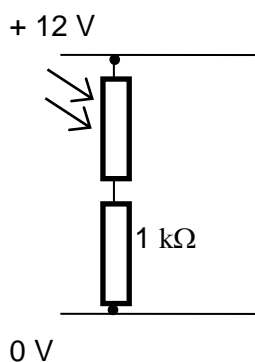

Use the information above to find the potential difference across the LDR when it is:

- (a) dark
- (b) light

23. Calculate the potential difference across the **resistor** in the following circuit when the temperature is:

- (a) 100°C
 (b) 40°C

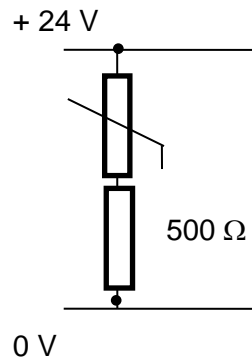

24. A young engineer designs part of an electronic system to trigger an alarm when it gets too bright.

Determine the 'trigger voltage' across the resistor in the following system when the light level becomes 'bright'.

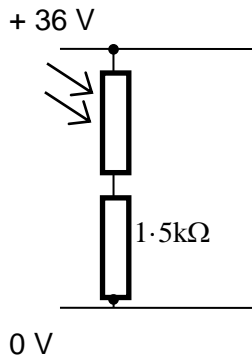

25. Determine the temperature at which the following voltmeters will show identical readings.

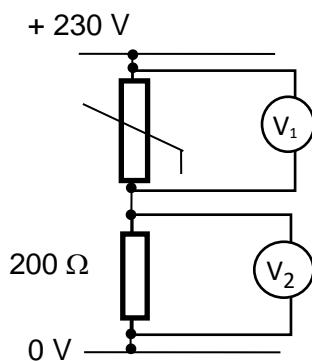

Helpful Hint

In a circuit like the following:

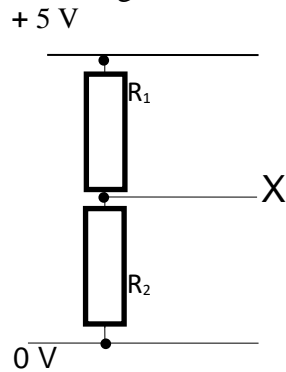

You are often required to calculate the “potential” at point X

This is the same as the voltage (or potential difference) across resistor R_2 .

Calculate the potential at X in questions 26 - 30.

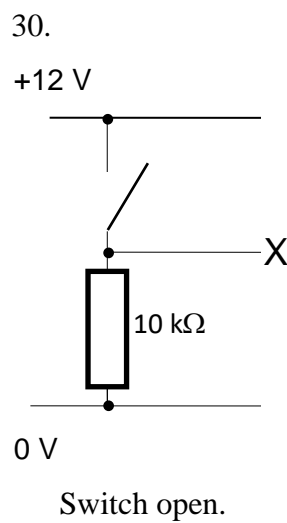
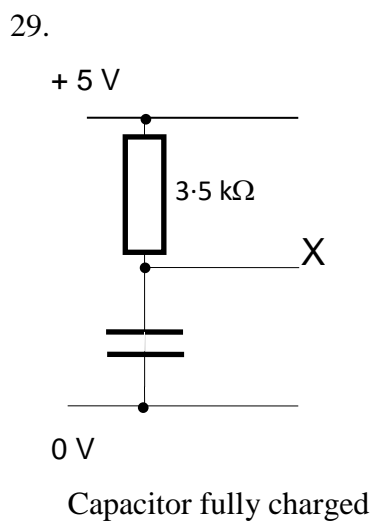
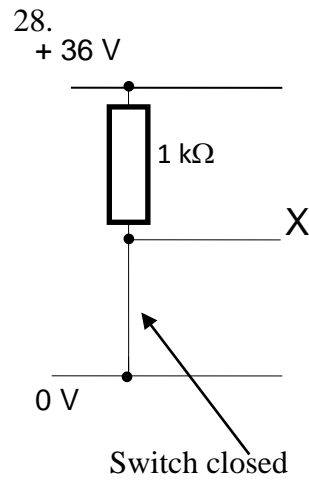
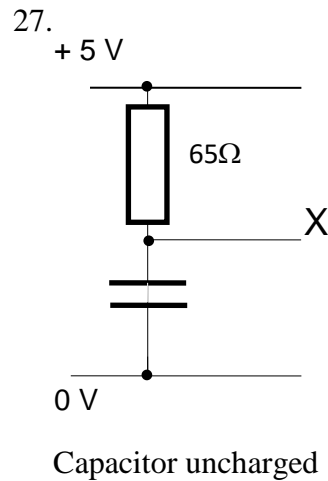
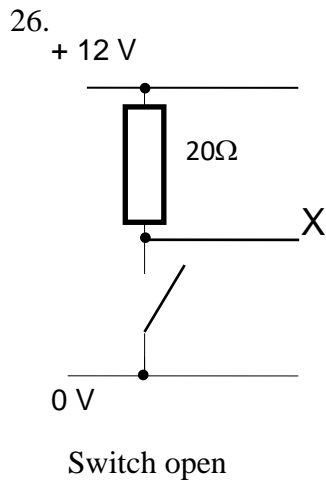

22. Transistor Basics & Switching Circuits

National 5 (Transistor Basics)

1. Draw the symbol for the npn transistor and label each terminal.
2. For what do the letters MOSFET stand?
3. Draw the symbol for the n-channel enhancement MOSFET and label each terminal.
4. Transistors can be used as switches that are controlled by a voltage.
 - (a) State the switching voltage for the npn transistor.
 - (b) State the switching voltage for the n-channel enhancement MOSFET.
5. On your diagrams for questions 1 and 3, indicate where this “switching voltage” should be.

National 5 Extension (Switching Circuits)

Helpful Hint

A transistor operates as a switch in a circuit. An npn transistor switches ‘ON’ when the voltage across XY, in the diagram below, is above approximately 0.7 V.

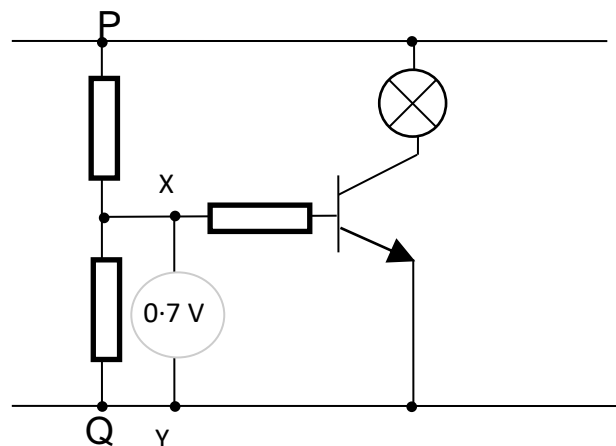

For the n-channel enhancement MOSFET, this switching voltage is approximately 2V.

In the last section you studied potential dividers. A potential divider is usually placed between P and Q. Various components can be used to make up the potential divider but it is always the potential difference across XY which switches on or off the transistor.

Some examples are shown on the next page.

Examples for the NPN Transistor

(a) The potential divider can be two resistors in series

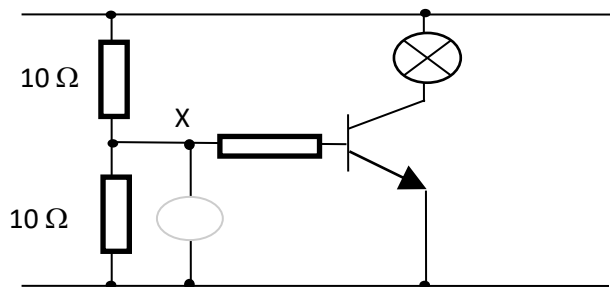

(b) The potential divider can be a Potentiometer

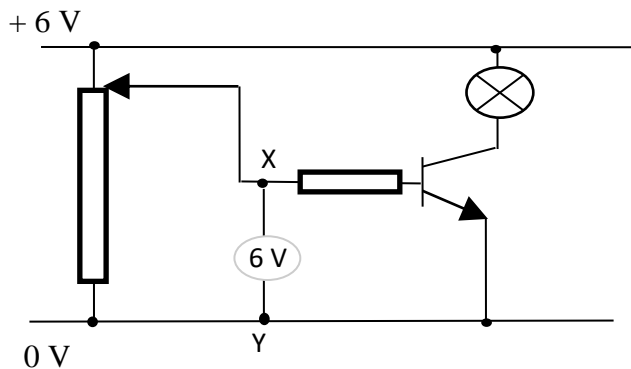

Voltage across XY is 6 V so transistor conducts and bulb lights.

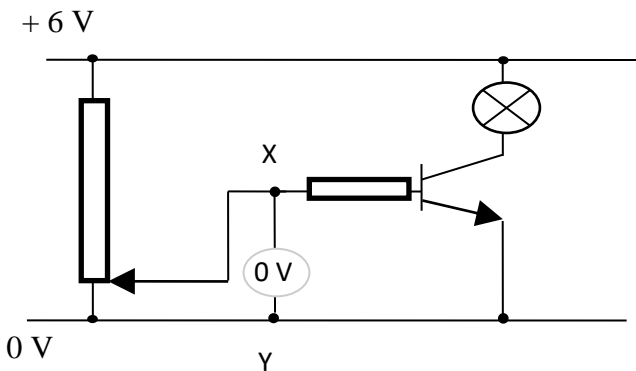

Voltage across XY is 0 V so transistor does not conduct therefore bulb is OFF.

(c) The potential divider may contain a sensor (the words in **bold** will change depending on the type of sensor and its position in the potential divider.)

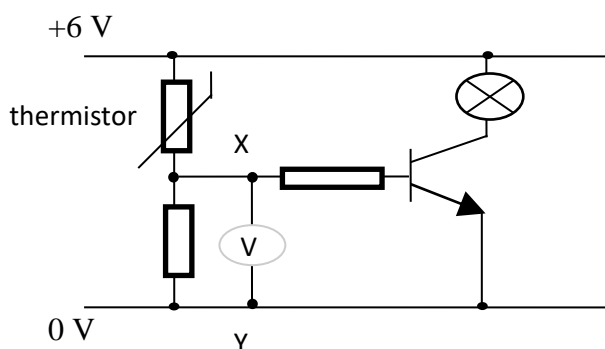

As the **temperature increases**, the resistance of the **thermistor decreases**.

So does its voltage.

This means the voltage across XY **increases**.

Eventually it will be **hot enough** that this voltage will become **greater than 0.7 V** so the transistor and **bulb** will switch **ON**.

1. For each of the following circuits calculate the potential difference across XY and then state whether the output device is ON or OFF.

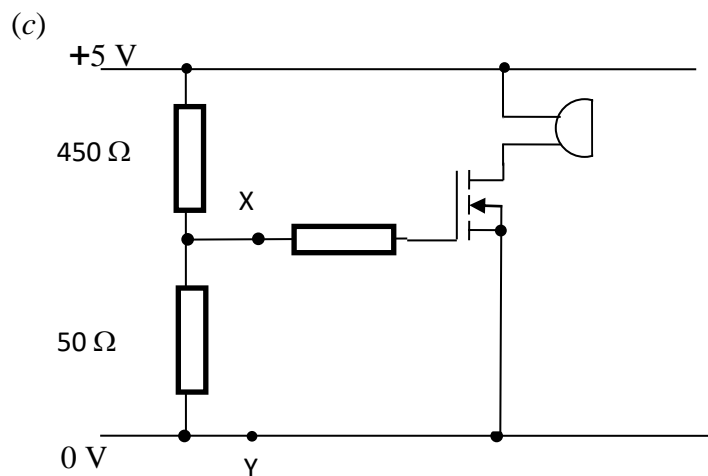
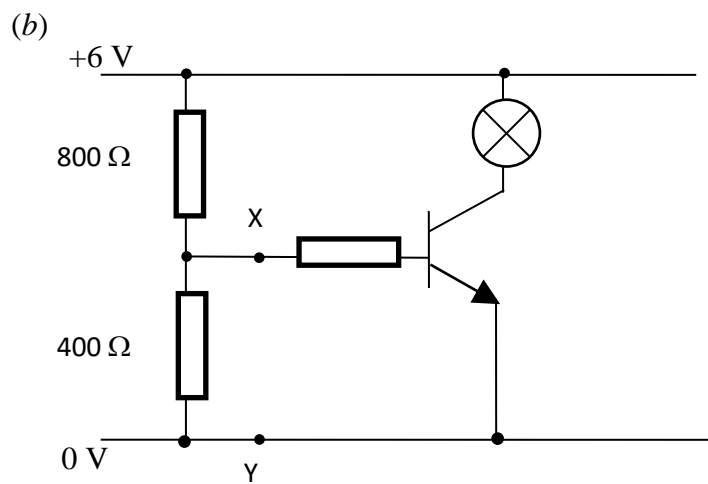
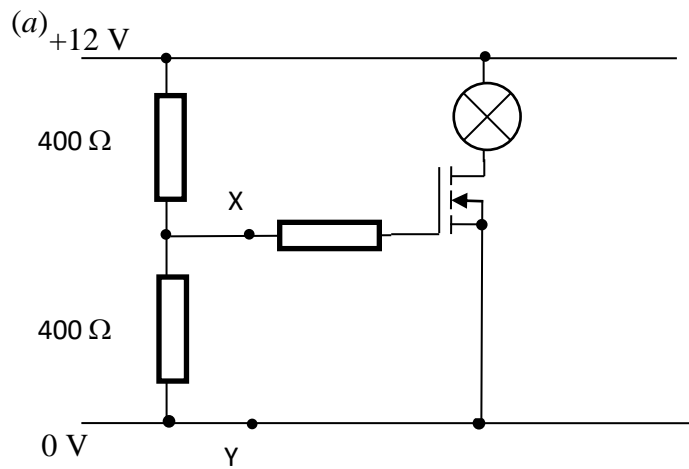

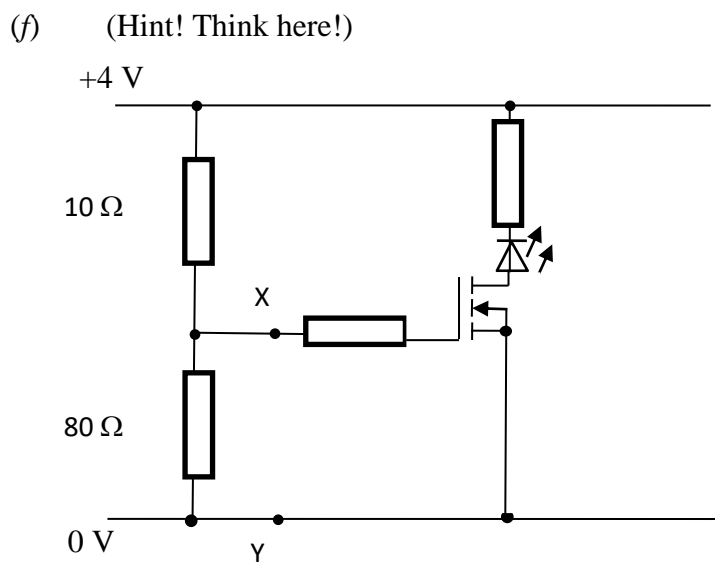
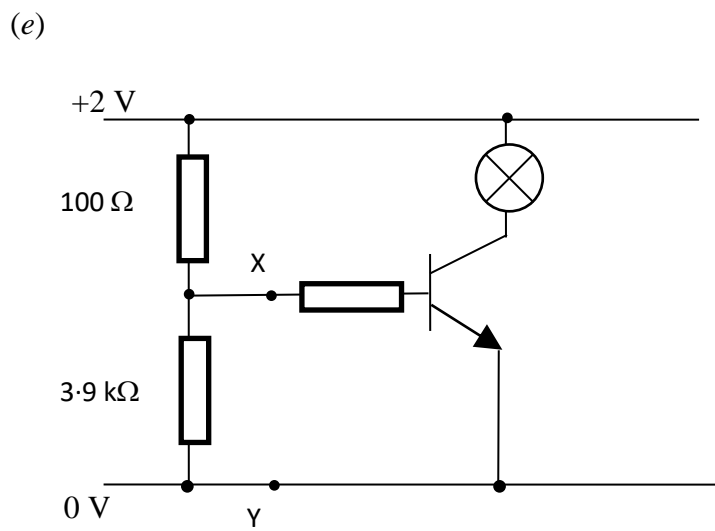
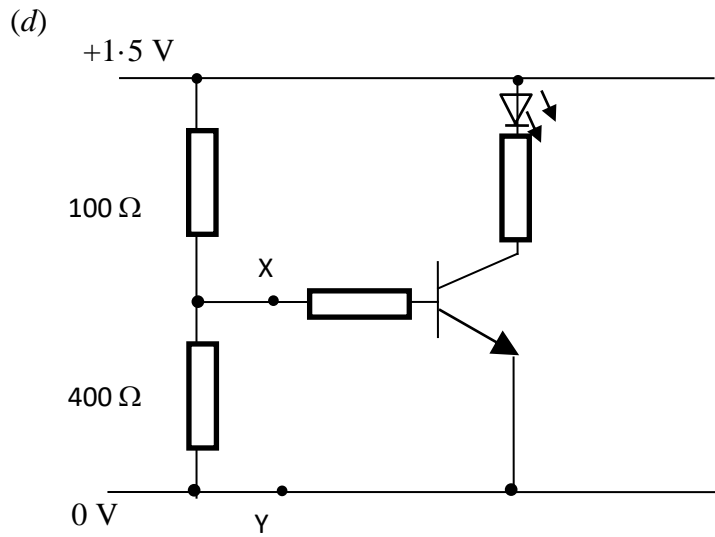

2. Consider the following circuit.

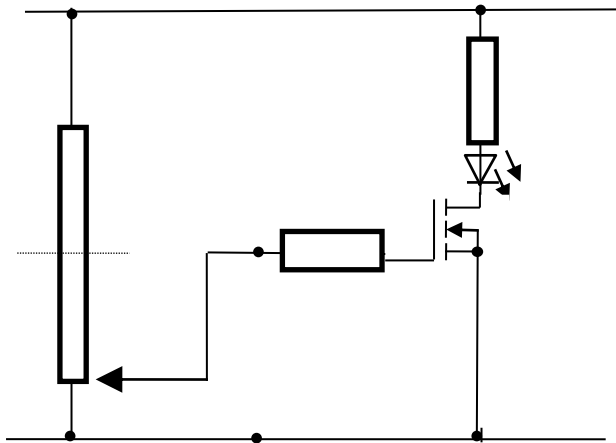

- What is the voltage across XY when the sliding connection is at point A?
- Does the LED light when the sliding connection is at point A?
- Does the LED light when the sliding connection is at point B? Explain your answer.
- Does the LED light when the sliding connection is at point C? Explain your answer.

3. The following circuit is used to switch on an electric heater automatically when the temperature in a room falls below a certain value.

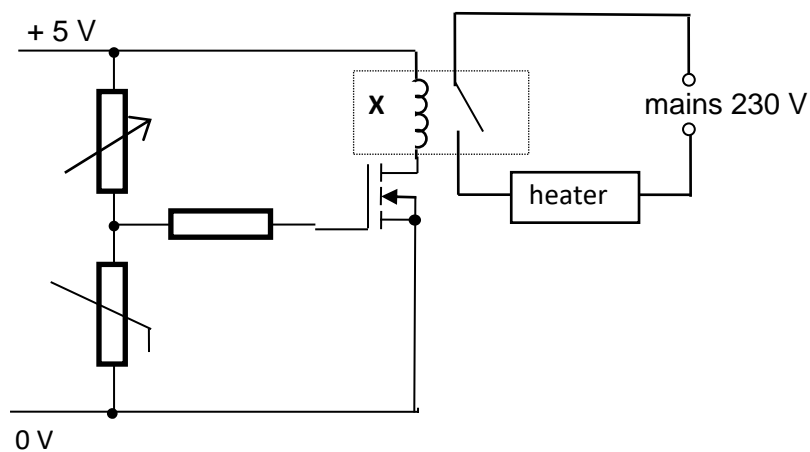

- Explain how the circuit operates.
- What would be the effect of decreasing the resistance of the variable resistor?
- Why would it be unsuitable to put the heater at point X instead of the relay?

4. Study the four circuits shown below.

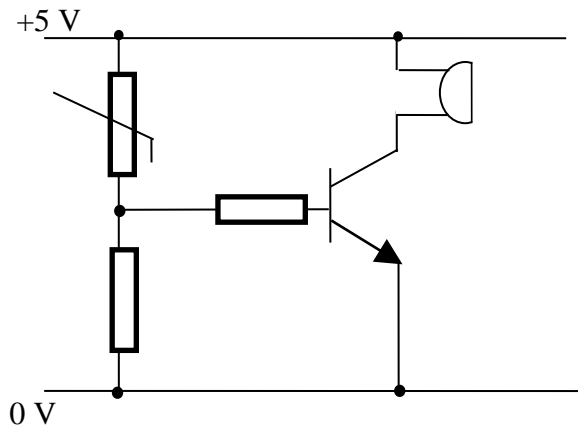

Circuit A

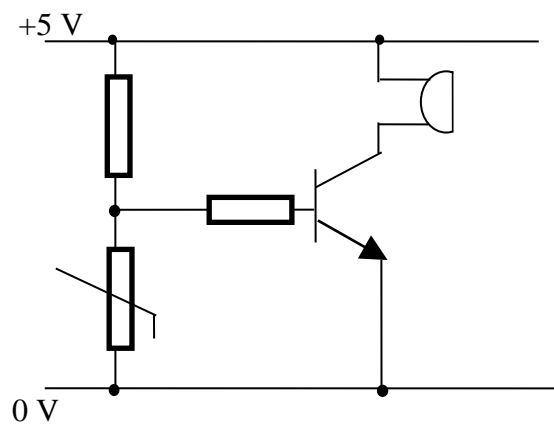

Circuit B

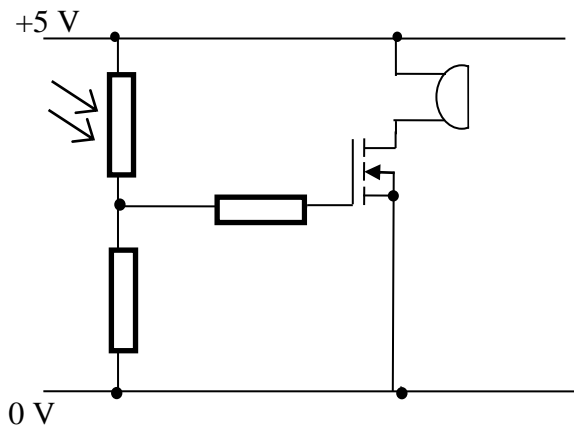

Circuit C

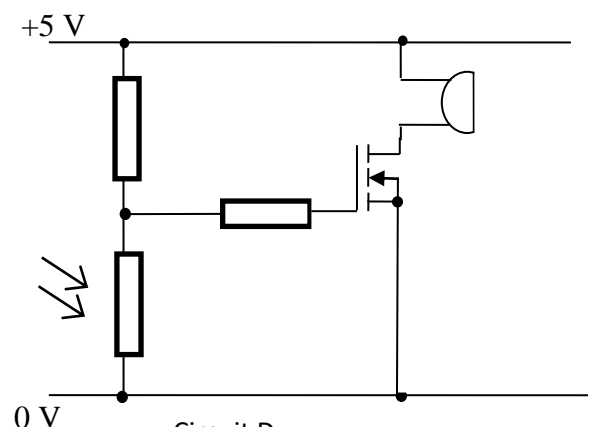

Circuit D

- Which circuit could be used to remind drivers at night to put on their headlamps? Explain your answer.
- Which circuit would be useful as a warning indicator of low temperature in an elderly person's house? Explain your answer.
- Which circuit could be used to waken campers when daylight arrives? Explain your answer.
- Which circuit would be most suitable as a fire alarm?

5. For each of the following circuits state whether the output device is ON or OFF and explain your answer.

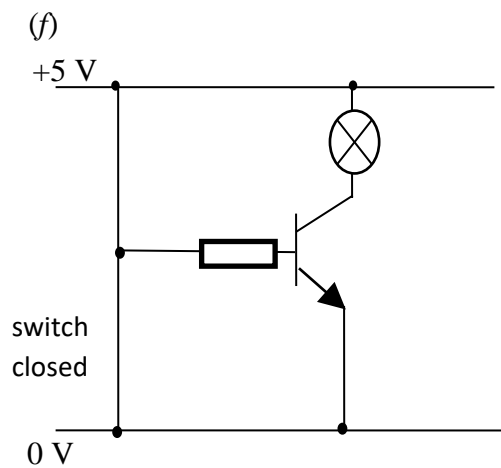
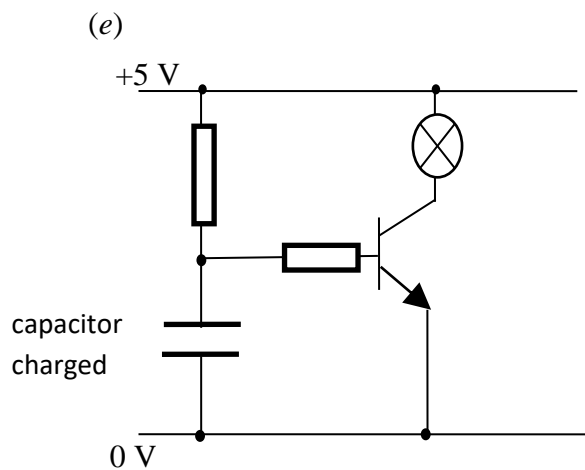
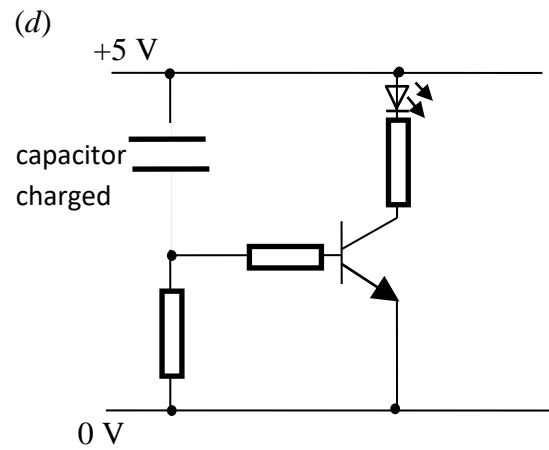
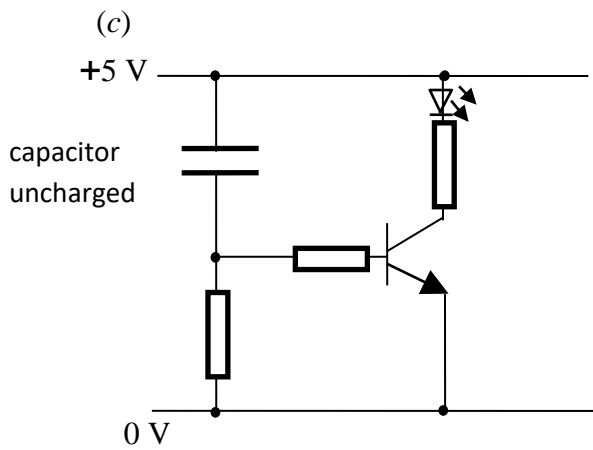
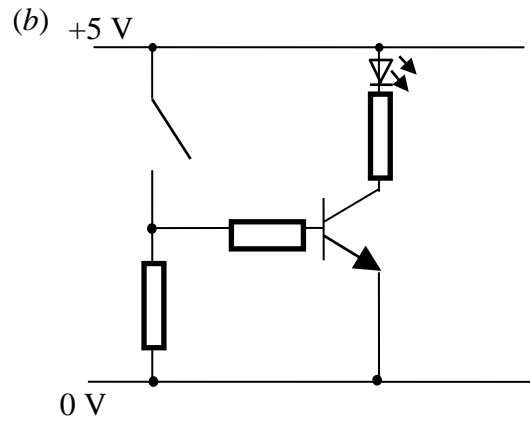
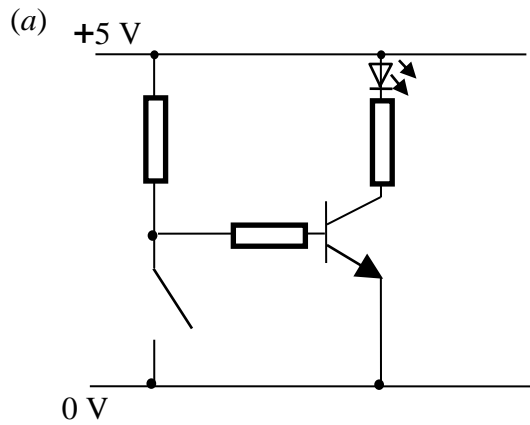

23. Pressure, Force and Area

National 5

In this section you can use the equation:

$$P = \frac{F}{A}$$

Where P = pressure in pascals (Pa) or newtons per square metre (Nm^{-2})
 F = force in newtons (N)
 A = area in square metres (m^2)

1. Find the missing values in the following table.

	<i>Pressure (Pa)</i>	<i>Force (N)</i>	<i>Area (m^2)</i>
(a)		120	1.6
(b)		4000	0.5
(c)	1.1×10^5		2.0
(d)	9000		8.0×10^{-2}
(e)	12 000	7.2×10^5	
(f)	1.4×10^4	4.9×10^4	

2. An elephant can exert a force of 5000 N by pressing his foot on the ground. If the area of his foot is 0.02 m^2 , calculate the pressure exerted by his foot.
3. A water tank has a weight of 9 800 N and a base area of 20 m^2 . It sits on a floor. Calculate the pressure exerted by the tank on the surface of the floor.
4. A syringe has a piston with a cross-sectional area of $2 \times 10^{-4} \text{ m}^2$. The piston is pushed with a force of 12 N. Calculate the pressure.
5. A drawing pin has a sharp point with an area of $1 \times 10^{-8} \text{ m}^2$. Calculate the pressure exerted by the point when the head is pushed with a force of 8 N.
6. Explain why the use of large tyres helps to prevent a tractor from sinking into soft ground.



7. If you want to rescue someone who has fallen through ice on a pond, would it be easier to walk or crawl across the ice towards him? Explain why.
8. A 0.48 kg tin of baked beans is a cylinder with a radius of 3.2×10^{-2} m. It is placed on a kitchen counter.
- Calculate the weight of the tin. This is the force it exerts on the counter.
 - Calculate the area of the tin in contact with the counter.
 - Calculate the pressure on the counter caused by the tin.
9. A television has a length of 1.24 m, a height of 0.93 m and a depth of 0.08 m.

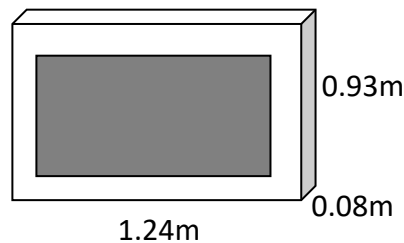

The mass of the television is 30 kg and it sits on a table.

- Calculate the weight of the television. This is the force it exerts on the table.
 - Calculate the area of the television in contact with the table.
 - Calculate the pressure on the table caused by the television.
10. A car of mass 1250 kg is driven on to a bridge. The pressure on the surface of the bridge when all four tyres are on the ground is 39.0 kPa.
- Calculate the weight of the car.
 - Calculate the total contact area of the car's tyres on the bridge.
 - Determine the contact area of one tyre.
11. A 50 kg ballerina can exert a pressure of 2.2×10^6 Pa when she stands on one pointed foot. Determine the area of the point of her ballet shoe. (Remember to calculate the weight of the ballerina first!)



12.  A tank exerts a pressure of only 3.675×10^4 Pa on the ground due to the large surface area of its tracks which is 8 m^2 .
- Calculate the weight of the tank. This is the force it exerts on the ground.
 - Calculate the mass of the tank.

13. The surface area of a person's head is approximately 0.5 m^2 . Calculate the force exerted by the air on the person's head, given that air pressure is $1 \times 10^5 \text{ Pa}$.
14. Measuring the total weight of yourself and your lab stool then measure the contact area of one leg of the stool in "swinging position". Calculate the pressure that is exerted on the floor when you swing on your stool.
15. In an experiment, weights are placed on top of a syringe filled with trapped air. A Bourdon Gauge is used to measure the air pressure inside the syringe. This is then repeated for different weights. The results are shown in the table.

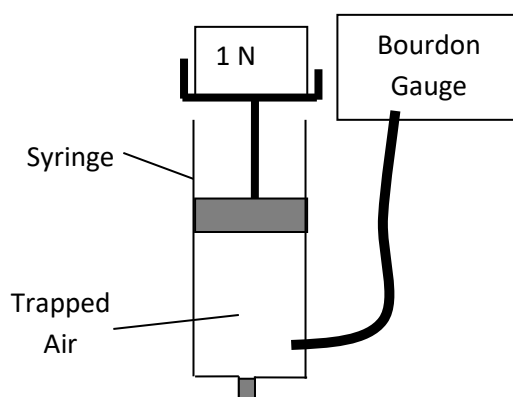

<i>Force (N)</i>	<i>Total Pressure (x 10⁵ Pa)</i>	<i>Pressure due to added weight (x 10³ Pa)</i>
0	1.01	0
1	1.03	2
2	1.05	4
3	1.07	6
4	1.09	8
5	1.11	10

Use this data to construct a line graph of force against pressure due to the added weight, and use the gradient of the straight line to calculate the surface area of the plunger inside the syringe.

24. Kinetic Theory of Gases

National 5

1. Explain what is meant by the following terms, in relation to a gas:
 - (a) volume
 - (b) temperature
 - (c) pressure
2. Air is trapped inside a conical flask, as shown below, and the flask is heated. The temperature and the pressure of the trapped air are monitored as the air is heated. The results are shown in the table.

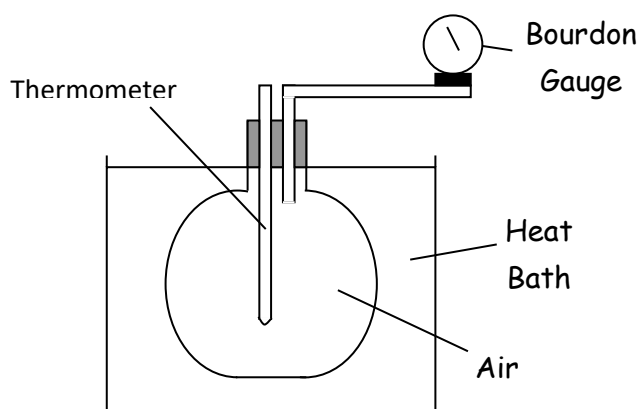

<i>Temperature</i> (°C)	<i>Pressure</i> (x 10 ⁵ Pa)
20	1.01
30	1.04
40	1.08
50	1.11
60	1.15
70	1.18

- (a) Using the data, draw a line graph of pressure against temperature (in degrees Celsius). Make sure that your temperature axis goes from -300 °C to 70 °C.
- (b) On your graph from part (a), continue your straight line back until it crosses through the x-axis. At what temperature would the pressure of the gas reach zero?
- (c) Explain why the temperature you determined in part (b) is known as “absolute zero”.
- (d) Explain, using the kinetic theory of gases, why the air pressure increases as the temperature increases.

3. The following apparatus is designed to investigate how changing the volume of trapped air will affect the pressure of the trapped air. Air is trapped above a pillar of oil and its volume can be measured using a scale on the pillar. The pressure of the air can be measured with the Bourdon Gauge.

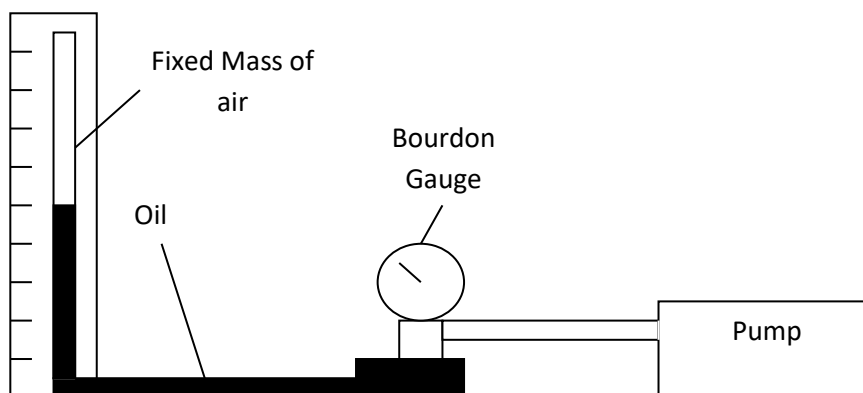

The pump is used to raise the level of oil and reduce the volume of air.

It is observed that, as the volume of trapped air decreases, the pressure increases.

In fact, it is found that, provided the temperature remains constant, the pressure is inversely proportional to the volume.

$$P \propto 1 / V$$

Use the kinetic theory of gases to explain this result.

4. Explain, using the appropriate gas law, why a balloon will burst if you squeeze it.

5. In an experiment, an open capillary tube with a mercury thread is placed in to a heat bath.
- As the temperature of the gas increases, the mercury thread moves up the capillary tube.
- The pressure of the gas remains constant because the capillary tube is open.
- The temperature of the gas is measured with a thermometer and the volume of the gas is measured using a scale next to the open capillary tube. The results of the experiment are shown.

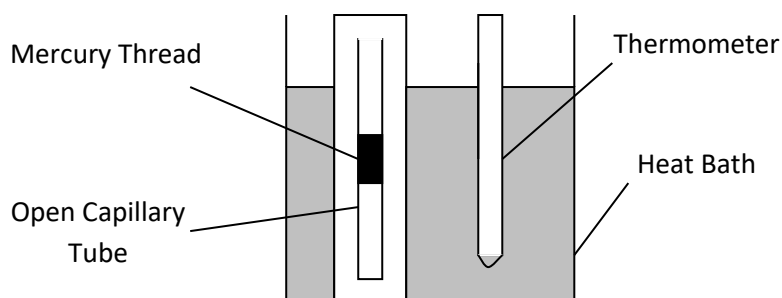

<i>Temperature</i> (°C)	<i>Temperature</i> (K)	<i>Volume</i> (cm ³)
20		1.50
25		1.88
30		2.25
35		2.63
40		3.00
45		3.38

- (a) Copy the table and complete it to show the temperatures in Kelvin.
- (b) Draw a line graph of volume against temperature (in Kelvin).
- (c) What conclusion can you make from this graph?
- (d) Explain this result in terms of the kinetic theory of gases.

25. The Gas Laws

National 5

In this section you can use the gas equations:

$$P_1V_1 = P_2V_2$$

$$\frac{P_1}{T_1} = \frac{P_2}{T_2}$$

$$\frac{V_1}{T_1} = \frac{V_2}{T_2}$$

Together these equations form the General Gas Equation:

$$\frac{P \cdot V}{T} = \text{constant}$$

or

$$\frac{P_1V_1}{T_1} = \frac{P_2V_2}{T_2}$$

Where P = pressure in pascals (Pa) or atmospheres (atm)
 V = volume in cubic metres (m³) or litres (l) ... or any suitable unit
 T = temperature in **KELVIN (K)**

Kelvin temperatures must be used in these calculations.

REMEMBER:

- **KELVIN is ALWAYS GREATER by 273.**
- **KELVIN temperatures are ALWAYS POSITIVE.**
- **A change in temperature in Kelvin is the same as a change in temperature in degrees Celsius.**

1. Convert the following temperatures from °C to Kelvin.
(a) 27°C (b) 100°C (c) 0°C (d) -50°C
2. Convert the following temperatures from Kelvin to °C.
(a) 400K (b) 10K (c) 273K (d) 97K
3. The temperature of water in a beaker rises from 20 °C to 80 °C.
(a) Calculate this change in temperature in °C.
(b) Calculate this change in temperature in K.

Pressure & Volume

4. A sealed syringe contains 100 cm³ of gas. The gas in the syringe has a pressure of 105 kPa. The syringe plunger is pushed in to a new volume of 50 cm³. Calculate the new pressure of the gas.

5. In an experiment the temperature of a fixed mass of gas is kept constant. The volume is altered and various readings of pressure and volume are taken. These are shown below.

Without drawing a graph, but by using all of the data, what conclusion can you make from these results?

Volume (cm ³)	45	39	37	34	25	22	18
Pressure (kPa)	101	116	122	135	180	210	250

6. A fixed mass of gas is kept at constant temperature but the pressure is increased from 1.01×10^5 Pa to 3.00×10^5 Pa. The initial volume was 0.2 m^3 . Determine the final volume.
7. A weather balloon contains 100 m^3 of helium when atmospheric pressure is 90 kPa. If the atmospheric pressure changes to 100 kPa calculate the new volume of helium at the same temperature.
8. A 5 cm^3 syringe is filled with air and the pressure of the air is found to be 1.01×10^5 Pa. The syringe plunger is then pushed until there is 3 cm^3 of air. Calculate the new air pressure.
9. A scuba diving air tank has a volume of 7.5 litres and is filled with air at a pressure of 1.21×10^7 Pa. Determine the volume this air would occupy at atmospheric pressure (1.01×10^5 Pa).



Pressure & Temperature

10. A glass flask contains a fixed volume of gas. The pressure of the gas is 114 kPa when the temperature is 27°C . Calculate the new pressure of the gas when the temperature is reduced to 0°C . Remember to change your temperatures to Kelvin!
11. The pressure of a fixed mass of gas is 200 kPa at 40°C and the volume is 1.5 m^3 . The temperature is increased to 100°C but the volume remains the same. Calculate the new pressure.
12. The pressure of air in a car tyre is 2.5×10^5 Pa at a temperature of 27°C . After a motorway journey the pressure has risen to 3.0×10^5 Pa. Assuming the volume of air in the tyre has not changed, calculate the resulting temperature of air in the tyre.

13. At a temperature of $20\text{ }^{\circ}\text{C}$, the pressure of a fixed mass of gas in a sealed container is found to be 104 kPa . The gas is heated to a uniform temperature of $90\text{ }^{\circ}\text{C}$ using a heat bath. Calculate the pressure of the gas at a temperature of $90\text{ }^{\circ}\text{C}$.
14. The pressure of the air in a lorry tyre is found to be $2.58 \times 10^5\text{ Pa}$ at the end of a journey. Once the tyre has cooled down, the temperature of the air inside the tyre is found to be $10\text{ }^{\circ}\text{C}$ with the pressure decreasing to $2.41 \times 10^5\text{ Pa}$.

Calculate the temperature of the air in the tyre at the end of the journey.

Temperature & Volume

15.



A sealed syringe has a volume of 30 ml when the temperature of the gas in the syringe is $15\text{ }^{\circ}\text{C}$.

Calculate the new volume of the gas when the temperature is changed to $30\text{ }^{\circ}\text{C}$.

16. The volume of a fixed mass of gas is 40.0 cm^3 at $20\text{ }^{\circ}\text{C}$. The temperature of the gas is increased to $40\text{ }^{\circ}\text{C}$ without changing the pressure.
A student makes this statement:

'As the temperature of the gas has doubled, the volume of the gas will also double. Therefore, the volume of the gas at $40\text{ }^{\circ}\text{C}$ will be 80.0 cm^3 .'

- (a) Explain why this statement is incorrect.
(b) Calculate what the volume of the gas would actually be at $40\text{ }^{\circ}\text{C}$.
17. Air is trapped in a glass capillary tube by a bead of mercury. The volume of air is found to be 0.15 cm^3 at a temperature of $27\text{ }^{\circ}\text{C}$.
Assuming that the pressure of the air remains constant, what is the volume of the air at a temperature of $87\text{ }^{\circ}\text{C}$?

Pressure, Temperature & Volume

18. A fixed mass of gas is trapped in a syringe. The gas has a pressure of $1.63 \times 10^5\text{ Pa}$ when it has a volume of 3.0 cm^3 and a temperature of $22\text{ }^{\circ}\text{C}$.
The gas is then heated until it has a uniform temperature of $57\text{ }^{\circ}\text{C}$ and a volume of 5.0 cm^3 .
Calculate the new pressure of the gas.



26. Applications of The Kinetic Model of a Gas

National 4

1. Explain why the pressure in car tyres increases as more air is pumped in.
2. Explain why car tyres are marked with a maximum pressure limit.
3. The air pressure decreases, the higher we go from the surface of Earth.
 - (a) Explain why aircraft cabins must contain pressurised air.
 - (b) Predict and explain what might happen if an explosion happened on an aeroplane at 40 000 feet, blowing open a door.
4. The summit of Mount Everest is at 8848 m. At this height the air pressure is approximately one third of the air pressure at sea level. In addition, the temperature at the summit of Everest averages around -19°C in summer, dropping to -36°C in winter.



- (a) Use your knowledge of temperature and pressure to explain why you think it is very difficult to survive for very long at this altitude.
- (b) Research what the main health risks are for high altitude climbers, due to the drop in air pressure.

5. Read the information below and overleaf and use it to answer the questions that follow:

The Dangers of Scuba Diving

As scuba diving is a popular recreational sport, beautiful coral reefs and eerie shipwrecks around the world have become major tourist draws in their own right. However, it should not be forgotten that scuba diving is an extreme sport with its own peculiar injuries and potentially life-threatening hazards. Most of these scuba diving dangers stem from the effects of the increased water pressure of the undersea environment, but there are also dangers posed by sea life and faulty equipment.



Barotrauma

Barotrauma is caused by the damage done by increased underwater pressure on the air pocket in the middle ear. Divers usually "equalize" during a dive by pinching their nose shut and blowing, by chewing or by swallowing to push more air into the middle ear. However, a descent that is too fast can result in severe pain and even injury to the middle ear.

Decompression Sickness

Often called "the bends," decompression sickness is caused by increased underwater pressure causing the body's tissues to absorb more nitrogen. If that pressure is suddenly reduced, this extra nitrogen forms potentially harmful bubbles. Deep divers return to the surface in carefully monitored stages so as to control the rate at which this absorbed nitrogen is released. A case of the bends can range from aching joints or a skin rash to paralysis and death.

Nitrogen Narcosis

Another nitrogen-related danger is the narcotic effect of all that extra nitrogen in the body. Nitrogen narcosis is a danger because it impairs judgement and sensory perception. As with the bends, the degree of nitrogen narcosis is related to how deep a diver goes and how much nitrogen they absorb.

Oxygen Toxicity

Oxygen toxicity is usually a problem only encountered by deep divers who go below 135 feet. The body absorbs extra oxygen under increased underwater pressure. For most divers this is not a problem, but at extreme depths so much extra oxygen is absorbed that this life-giving gas becomes a poison. The effects range from tunnel vision and/or nausea to twitching to loss of consciousness and/or seizures.

Pulmonary Embolism

Another risk facing a diver who rapidly ascends to the surface is pulmonary embolism. The increased pressure of the undersea environment results in extra gas being crammed into the same lung space. A rapid rise to the surface can cause the lungs to swell and even pop like a balloon because the water pressure decreases. Scuba divers guard against pulmonary embolism by making slow, controlled ascents to the surface and by never holding their breath.

Sea Life

Divers should never forget that each dive is the equivalent of entering an untamed wilderness. While most sea creatures are not aggressive towards divers and attacks are extremely rare, incidents do happen and a diver cannot afford to forget that she is surrounded by wild animals. The famed TV wildlife host "Crocodile Hunter" Steve Irwin was killed in 2006 when he was stung through the chest by a stingray, a frequently encountered and usually harmless sea creature. Divers should always treat sea life with great care and respect.

Defective Equipment

Many casual scuba divers do not own their own equipment, and are therefore reliant on renting equipment from the scuba diving operator who is conducting their dive trip. A broken depth gauge could lead to a mild case of decompression sickness, while a bad regulator might result in drowning. A diver should always thoroughly check rented scuba diving equipment, and never be shy about asking for a new piece of gear if they suspect something is wrong with what they have.

Questions

1. Which part of the body can be damaged by "barotrauma"?
2. How can a diver prevent or reduce the effect of barotrauma?
3. What is the scientific term for "The Bends"?
4. "The Bends" is caused by the body absorbing which gas?
5. What other condition can be caused by the body absorbing too much of the gas in Q. 4?
6. In high pressure environments, like deep sea, the body can absorb too much oxygen. What are the effects of this?
7. If a diver gets into difficulty underwater, should the diver swim to the surface as quickly as possible? Explain your answer.
8. Apart from the dangers due to the change in water pressure, name two other hazards that might face a diver.