

National 4&5 Physics

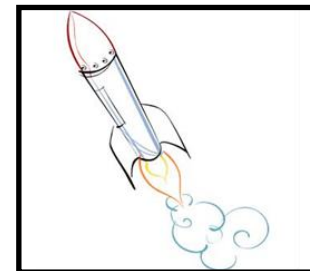
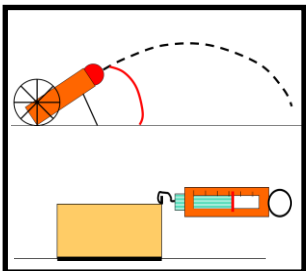
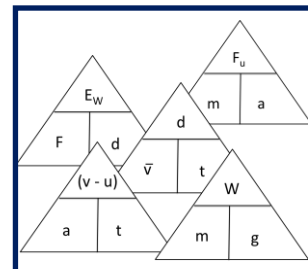
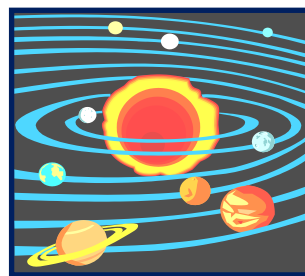
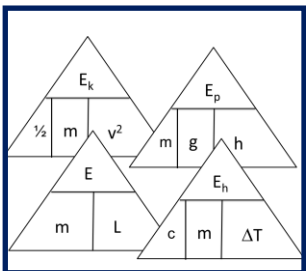
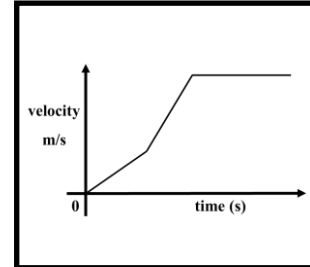
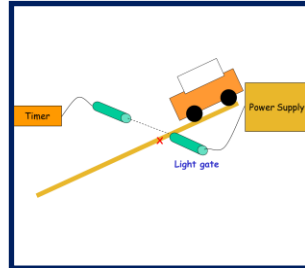

Dynamics and Space Homework

Homework 1. Average and Instantaneous Speed

1. A top class sprinter covers the 200m in a time of 19 seconds.
Calculate the sprinter's average speed.



3

2. How far would a motor cycle, travelling at an average speed of 80 kmh^{-1} travel in 6 hours?



3

3. How long will it take a Formula 1 car to travel one lap around a 5 km long circuit if it is travelling at an average speed of 180 kmh^{-1} ?

3

4. State the difference between average speed and instantaneous speed.

1

5. A cyclist rides along a road.

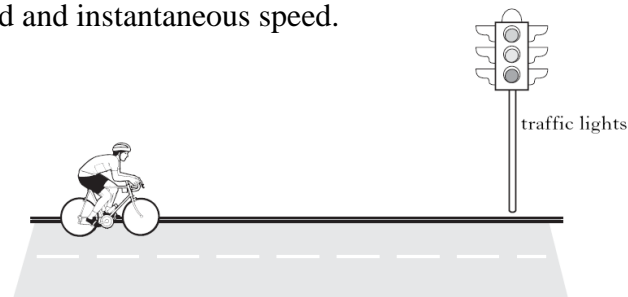

Describe a method by which the average speed of the cyclist could be measured.
Your description must include the following

- Measurements made
- Equipment used
- Any necessary calculations.

3

6. On a visit to a theme park, four students ride the log flume.

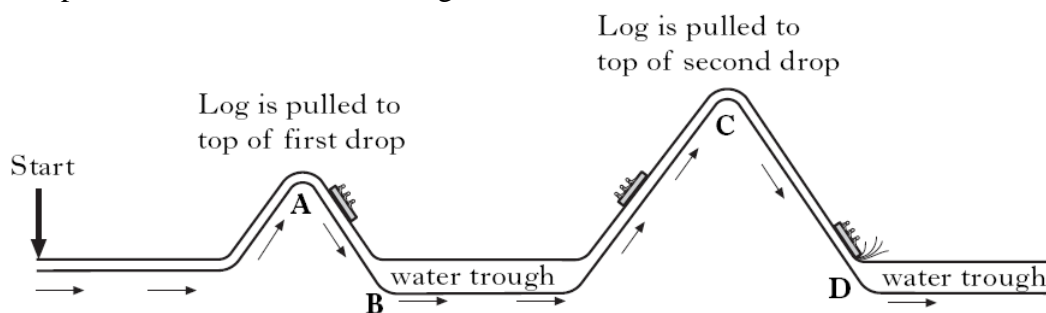

Not to scale

- (a) Describe how the instantaneous speed of the log could be measured at position **D** on the log flume.

3

- (b) Explain why using a stopwatch would give a poor result for instantaneous speed.

1

7. In an experiment to measure instantaneous speed, these measurements were obtained:

Reading on timer = 0.125 s

Length of card = 5 cm

Calculate the instantaneous speed of the vehicle in ms^{-1} .

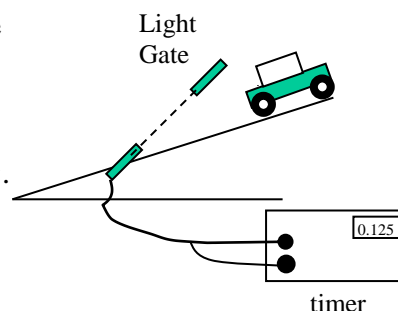

3

Total 20 marks

Homework 2. Vectors and Scalars

1. (a) Explain the difference between a vector and a scalar quantity. 1
 (b) State which of the following quantities are vector quantities and which are scalar quantities:

distance, displacement, velocity, speed. 2

2. Cumbernauld is 17.5 km north of Motherwell.
 A driver, following her Sat Nav, drives 27.1 km by motorway from Cumbernauld (C) to Motherwell (M).

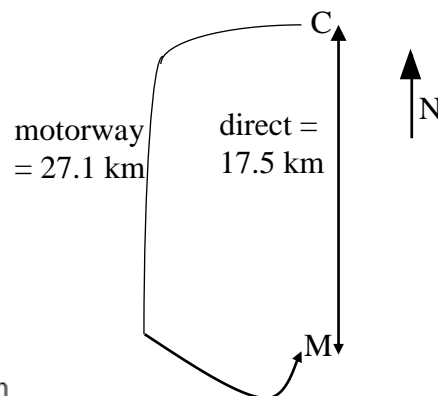

- (a) What distance has she driven? 1
 (b) What is her displacement at the end of the journey? 1

3. A car drives 60 km north, then 80 km east, as shown in the diagram
 The Journey takes 2 hours.

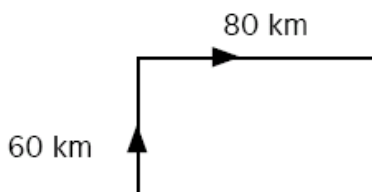

- (a) What is the distance travelled in km? 1
 (b) What is the displacement in km? 4
 (c) What is the average speed in kmh^{-1} ? 3
 (d) What is the average velocity in kmh^{-1} ? 3

4. A model aircraft is flying west with a velocity of 24 ms^{-1} .
 A wind is blowing from south to north at 7 ms^{-1} .
 Calculate the resultant velocity of the plane? 4



Total 20 marks

Homework 3. Acceleration Calculations

1. Calculate a car's acceleration if its speed increases by 12 ms^{-1} in a time of 3 s.

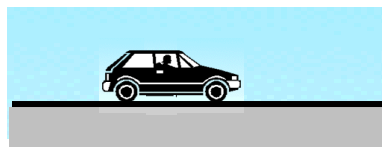

3

2. A cyclist accelerates from rest to 8 ms^{-1} in 5s. Calculate his acceleration.

3

3.

Car performance

Car	Max Speed (mph)	0 mph – 60 mph (seconds)
Audi A1 Quattro	142	4.9
BMW M5	148	3.6
Ferrari FXX Enzo	181	2.8
Jaguar XJ	150	4.7
Lamborghini Sesto	183	2.5

- (a) Which car has the greatest acceleration?

1

- (b) Which car has the smallest acceleration?

1

- (c) Calculate the acceleration of the Lamborghini Sesto

3

4. (a) A train travelling at 10 ms^{-1} accelerates to 20 ms^{-1} in 5 seconds. Find its acceleration.

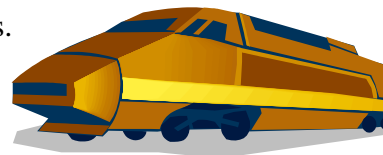

3

- (b) What will be its speed after a further 3 seconds if it continues to accelerate at the same rate?

3

5. A trolley is released from rest and runs down an incline plane, with its speed measured at two light gates. A stopwatch measures the time taken for the trolley to travel between the light gates.

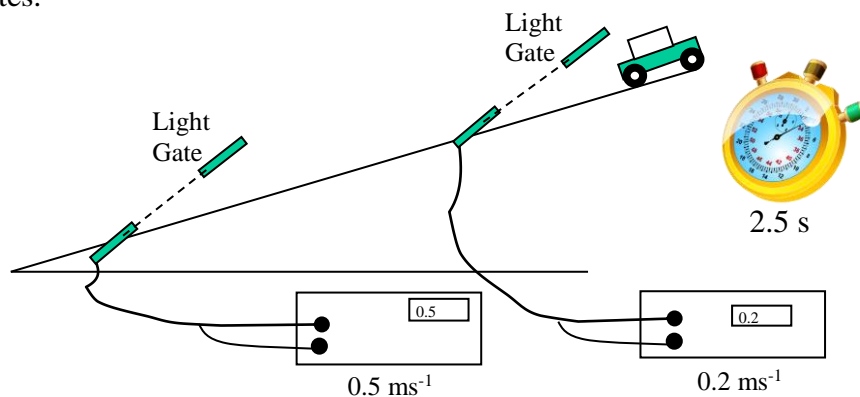

Calculate the acceleration of the trolley.

3

Total 20 marks

Homework 4. Velocity – Time Graphs

1. A car's speed is recorded over a period and the results are shown in the table below:

TIME (s)	SPEED (ms^{-1})
0	0
2	6
4	12
6	18
8	24
10	30

- (a) Plot a graph of the car's motion over this 10-second period. 3
- (b) From the graph, find the car's speed 5 seconds into its journey. 1
- (c) Describe the car's motion over the 10 seconds. 1

2. A hot air balloon is released and it accelerates upwards. During the ascent, some sandbags are released and the acceleration increases. The graph shows its vertical motion during the first 50 seconds of its flight.

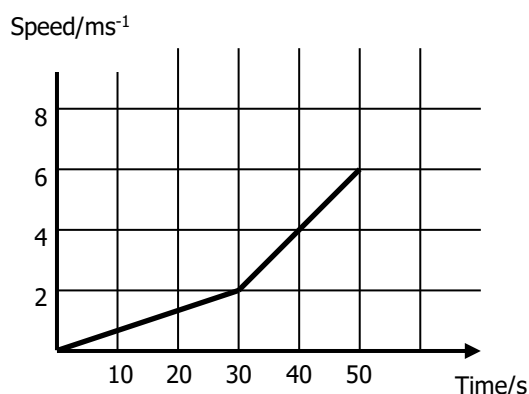

At which time were the sandbags released? Explain your answer. 2

3. Look at the graph. This shows the speed of a car over a short journey. Use the graph to answer these questions.

- (a) During which time is the vehicle travelling at a constant velocity? 1
- (b) Calculate the values of
- the initial acceleration 3
 - the final deceleration 3
- (c) What is the total distance travelled? 3
- (d) What is the average speed of the car? 3

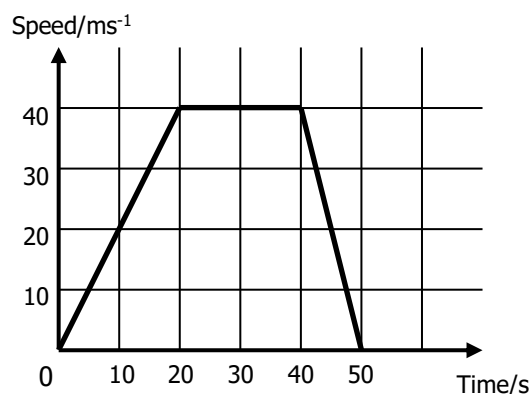

Total 20 marks

Homework 5. Forces

1. (a) A force is defined by the three main effects it may have on an object. Name any two of these.



2

(b) A tennis player applies a force on the ball with his racquet. Give one effect on the ball that proves a force has been applied.

1

2. (a) State what is meant by *gravitational field strength*.

1

(b) What is meant by the weight of an object?

1

3. Use the data sheet on page 1 of your problem book to answer this question.

(a) An astronaut weighs 120N on the moon.

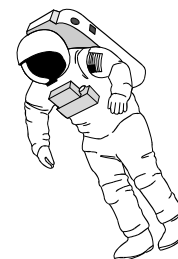

(i) What is her mass?

3

(ii) What is her weight on the earth?

3

(b) Find the weight of a 60 kg object on Mars.

3

4. (a) How does the direction of the force of friction relate to the direction of a vehicle's motion?

1

(b) What type of energy is produced whenever a moving object meets friction?

1

(c) State an example of where friction is helpful and we try to increase it.

1

(d) Give an example where we try to reduce friction as much as possible.

1

5. (a) A hiker walks across a rickety bridge as shown in the diagram. What is the name of the upward force that the hiker hopes is equal and opposite to his weight?



1

(b) The hiker is then airlifted to hospital. Name the upward force on the cable supporting his weight.



1

Total 20 marks

Homework 6. Newton's First Law

1. (a) Explain the term *balanced forces*. 1
- (b) What are balanced forces equivalent to? 1
- (c) State Newton's First Law. 1



2. Explain, using Newton's First Law, how a seat belt can prevent injury in a car crash. 2

3. A parachutist jumps out of an aircraft. Sometime later, the parachute is opened. The graph shows the motion of the parachutist from leaving the aircraft until landing.

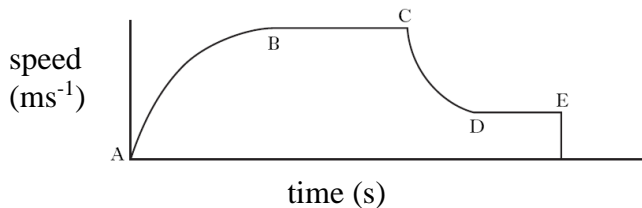

- (a) Which parts of the graph show when the forces acting on the parachutist are balanced? 1
- (b) The parachutist lands badly and is airlifted to hospital by helicopter. The stretcher and parachutist have a total mass of 90 kg.
 - (i) Calculate the weight of the stretcher and parachutist. 3
 - (ii) The parachutist is lifted by the helicopter cable at a constant speed. What is the tension in the cable? 1
- (c) State what happens at (i) point C (ii) point E 2

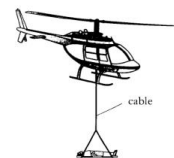

4. The diagram shows the forces acting on a balloon as it rises.

- (a) What will be the size of force A? 1
- (b) If the balloon was falling at constant velocity, what would be the size of force A? 1
- (c) What is the name of force A? 1

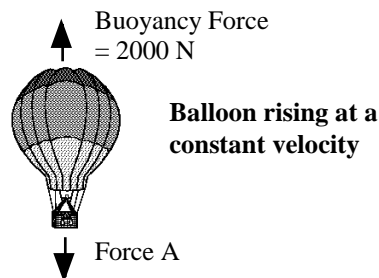

5. The diagram below shows the forces acting on a car moving at constant velocity.

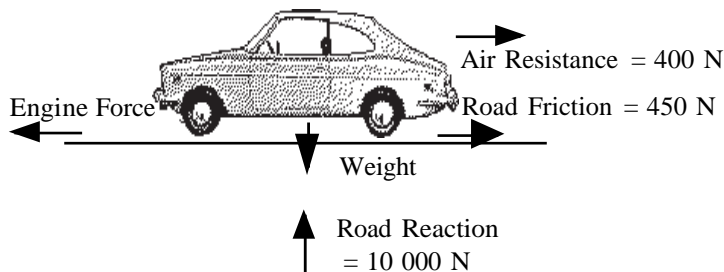

- (a) Calculate the size of the engine force? 1
- (b) Calculate the weight of the car? 1
- (c) Calculate the mass of the car? 3

Total 20 marks

Homework 7. Newton's Second Law

1. A boy of mass 45 kg slides down a frictionless chute in a swing park. His acceleration is initially 2 ms^{-2} . Find the force acting on him. 3
2. What will be the acceleration of a 12 kg mass acted on by a force of 30 N? 3
3. A car's engine applies a force of 3000 N, and this accelerates it at 4 ms^{-2} . Calculate the mass of the car. 3



4. The diagram below illustrates the forces acting on a motorbike. The combined mass of the bike and rider is 250 kg

- (a) Name the two forces shown
- (a) Calculate the resultant force acting on the bike.
- (b) Calculate the acceleration of the bike.



5. A helicopter winches an injured climber up from a mountainside. The climber's mass is 65 kg, and her weight is 637 N.
 - (a) If she is accelerated upwards at 2 ms^{-2} , what is the required unbalanced force? 3
 - (b) What total upwards force must be produced by the helicopter? 2



Total 20 marks

Homework 8. Newton's Third Law

1. Identify the 'Newton pairs' in the following situations:

- (a) A swimmer swimming a length in a swimming pool.
- (b) A car accelerating along a road.
- (c) An apple sitting on a table.
- (d) A cannon ball falling from the Leaning Tower of Pisa.



2. A young boy writing a project for primary school writes "a rocket is pushed upwards because of the gases pushing against the ground". His older brother, a physics student, points out that this is wrong. What should his project say? 2

3. An astronaut leaves the spacecraft to go to a small artificial satellite nearby. She has a jetpack strapped to her back. The backpack contains a pressurised gas cylinder connected to a valve. When the valve is opened, a jet of gas is released.

When the astronaut opens the valve, the cylinder exerts a force backwards on the gas.

- (a) Describe the force exerted by the gas.
- (b) Explain how she can move to her left.
- (c) Describe her motion once the jetpack is switched off. Explain your answer.

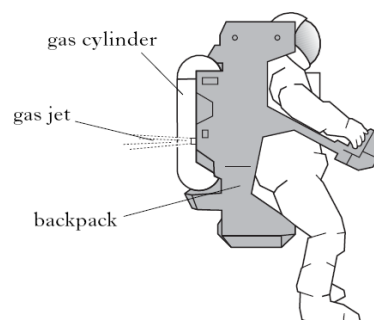

Total 10 marks

Homework 9. Projectiles

1. A distress line is fired horizontally from the top of a high cliff to a boat in the sea below with a horizontal speed of 50 ms^{-1} .

- What is the horizontal speed of the line 2 seconds later?
- What is the initial vertical speed of the line?
- Sketch the path taken by the line.
- Explain why the path is this shape.

1
1
1
2

2. A metal ball is dropped from an aeroplane flying at 100 ms^{-1} . It takes 20s to reach the ground.

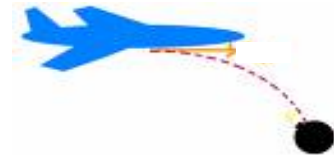

- State the horizontal speed of the ball just before it hits the ground.
- Calculate the total horizontal distance covered by the ball.
- Calculate the final vertical speed of the ball just before it hits the ground.
- Later, flying at the same height but at 150 ms^{-1} , another ball is dropped from the aeroplane. How long will it take for this ball to hit the ground? Explain your answer.

1
3
3
2

3. A ball is projected from the top of a table as shown.

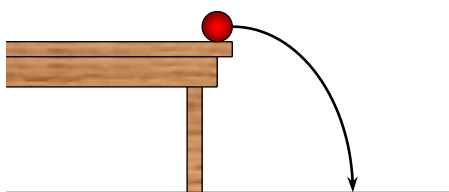

Two graphs are produced for this motion; one for the horizontal speed, and one for the vertical speed. These are shown below.

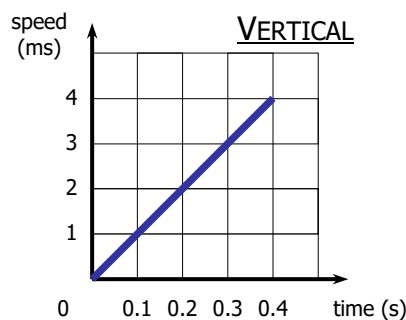
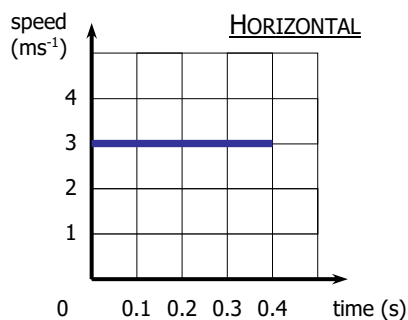

- How far out from the table did the ball land?
- How high is the table?

3
3

Total 20 marks

Homework 10. Work Done

1. (a) Explain what is meant by work done.
(b) Calculate the work done by a horse when it uses a force of 800 N to pull a sled a distance of 150 m.

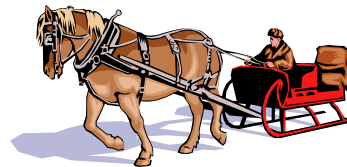

1
3

2. A man has to exert an average force of 280 N to push a trolley round a supermarket. If he does 208 kJ of work, how far does he walk?



3

3. A ski lift carries a skier to the top of a ski slope which is 250 m high. The total mass of the ski lift and the skier is 150 kg.

- (a) Calculate the total weight of the skier and the ski lift.
(b) Calculate the work done in lifting the skier and ski lift to the top of the slope.
(c) If the ski lift stops during the trip, how much work is required to hold it in position? Explain your answer.



3

3

2

4. A lorry has kinetic energy of 150 000 J.

- (a) How much work must be done to stop the lorry?
(b) If the lorry takes 75 m to come to rest, what braking force was applied?
(c) What type of energy is the kinetic energy being changed to?



1

3

1

Total 20 marks

Homework 11. Kinetic Energy and Potential Energy

1. Find the kinetic energy of a car of mass 800 kg travelling at 30 m/s.

3

2. A girl of mass 40 kg runs up a flight of stairs 12 m high.
Calculate the potential energy gained by the girl.

3

3. A lorry of mass 3000 kg has a kinetic energy of 121 500 J.
How fast is it travelling?

3

4. A roller coaster carriage has a mass of 300 kg when it is carrying a full load.



(a) How high is the carriage when its potential energy is 60 KJ

3

(b) What energy does it gain as it accelerates down the drop?

1

5. A mountaineer and her equipment have a combined weight of 800N.



How much potential energy will she gain if she climbs 150 m?

3

6. Name two quantities that affect a vehicle's kinetic energy.

2

7. An object has a potential energy of 5 J and a kinetic energy of 8 J.
Its height and speed then double.

(a) What is the object's new potential energy?

1

(b) What is the object's new kinetic energy?

1

Total 20 marks

Homework 12. Satellites and Space Exploration

1. The diagram shows a satellite in orbit around the earth.

(a) Explain why:

(i) The satellite does not move off in a straight line into space.

(ii) The satellite does not fall down to earth.

(b) What is the name of earth's natural satellite?

(c) Which object in space is earth a satellite?

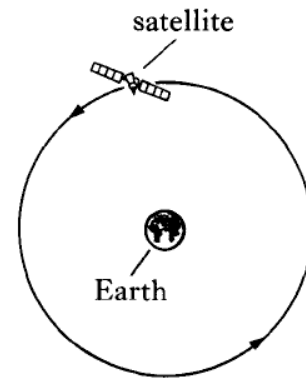

1
1
1
1

2. The table below gives information about artificial satellites that orbit the earth.

Name of satellite	Time for 1 orbit (minutes)	Height above Earth (km)	Use
Landsat	99	705	Land mapping
ERS-1		780	Monitoring sea levels
NOAA-12	102	833	Distribution of ozone layer
Early Bird	1440	35 900	Continuous telecommunication



NOAA-12 uses radio waves to transmit signals relating to the ozone layer.

(a) What is the speed of radio waves?

(b) Calculate the time for a signal to travel from NOAA-12 to an Earth station immediately below the satellite.

(c) Signals transmitted from NOAA-12 have a frequency of 137 MHz. Calculate the wavelength of these signals.

(d) Using the information about the time for one orbit, explain why the Early bird satellite is used for continuous telecommunication between two points on the earth's surface.

(e) Using the information in the 'Height above Earth' column, give an approximate time in minutes for how long ERS-1 would take to orbit the earth.

1
3
3
1
1

3. We use many methods to collect information about the universe.

(a) Copy and complete the following table to show the two types of signal which can be detected by Earth based telescopes and the type of telescope used to study each.

Type of signal	Type of telescope



4

(b) Why are terrestrial telescopes unable to detect other types of radiation from space?

(c) How are other types of radiation detected?

(d) Apart from using telescopes, how do we collect information about planets in our solar system?

1
1
1

Total 20 marks

Homework 13. Specific Heat Capacity and Specific Latent Heat

Use the data sheet on page 1 of your problem book to answer these questions.

1. How much heat energy is required to:
 - (a) Heat 2 kg of water in a kettle from 20°C to 100°C? 3
 - (b) Heat 2 kg of water in a tank from 20°C to 60°C? 1
2. In an experiment to determine the specific heat capacity of iron, the following experiment is set up:

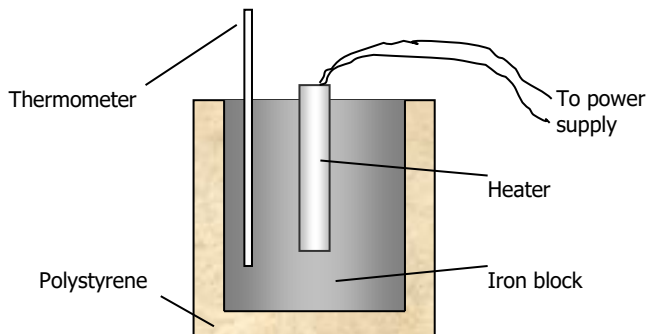

The block of iron has a mass of 2 kg. The heater supplies 6000 J of heat energy to the block. The temperature rises from 20°C to 26.25°C.

- (a) What value do these figures give for the specific heat capacity of iron? 3
 - (b) Why was the block encased in polystyrene? 1
3. A kettle contains 1.5 kg of water. Its automatic cut-off is broken, meaning it will not switch off when it starts to boil. Calculate how much heat energy would be required to turn all of the water into steam. 3
4. What mass of water could be turned into ice if a freezer removed 165 000 J of heat energy? 3



5. The graph below shows how the temperature of a 2 kg lump of solid wax varies with time when heated.

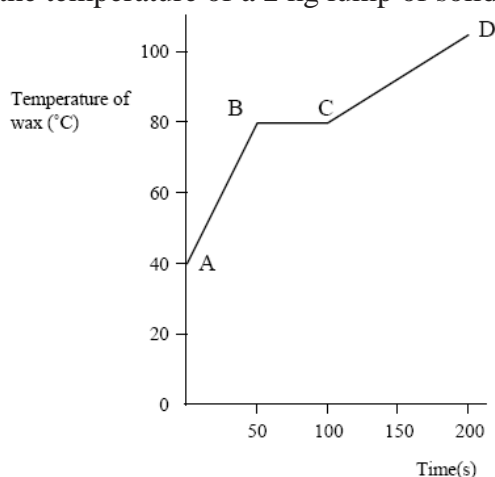

- (a) Explain what is happening to the wax in the regions AB, BC and CD. 3
 - (b) If a 10 000 J was used to melt the wax, calculate the specific latent heat of fusion of the solid wax. 3

Total 20 marks

Homework 14. Re-Entry, Cosmology and the Light Year



1. A space shuttle returning to Earth has a mass of 75 000 kg.
It is travelling at 7000 ms^{-1} as it re-enters the earth's atmosphere.
- (a) What is the shuttle's kinetic energy? 3
- (b) If the tiles that make up the shuttle's outer skin have a mass of 3000 kg, calculate the rise in temperature of the tiles. Assume that no energy is lost to the surroundings.
(Specific heat capacity of the tiles = $1040 \text{ Jkg}^{-1}\text{C}^{-1}$) 3
- (c) As the space shuttle passes through the atmosphere, an average of $1.5 \times 10^8 \text{ J}$ of kinetic energy transfers to heat energy for each kilometre it travels.
On average how much work is done by the frictional force to change kinetic energy to heat energy for each kilometre of the journey back to earth? 1
- (d) Calculate the average frictional force acting on the space shuttle during re-entry. 3
2. (a) What is the definition of a light year? 1
- (b) Betelgeuse is the eighth brightest star in the night sky. It is about 640 light years from Earth.
- (i) How long does it take for light to travel from Betelgeuse to Earth? 1
- (ii) How far is it from Betelgeuse to Earth in kilometres? 3
3. The next nearest star to Earth after the sun is Proxima Centauri, about $4.07 \times 10^{13} \text{ km}$ away.
- (a) How long does it take for light to travel from Proxima Centauri to Earth? 3
- (b) Express the distance to Proxima Centauri in light years. (You must show all working) 2

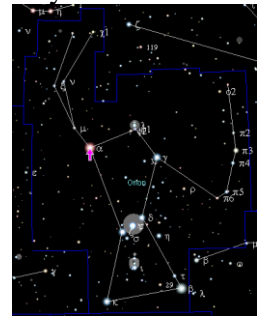

Total 20 marks

Homework 15. The Observable Universe

1. (a) Match the following explanations with the appropriate space term.

TERM	EXPLANATION
Moon	A massive object in space, consisting mainly of very hot gases, and producing vast amounts of energy.
Planet	The nearest star to Earth.
Sun	A huge cluster of stars.
Star	The Sun and the nine planets that orbit it.
Solar System	This moves around a star, held by its gravitational field. There are eight in orbit around the sun.
Galaxy	This is a natural satellite of a planet. The Earth only has one, but some planets have many.

- (b) What is the name of the galaxy that contains earth? 1
2. (a) State three requirements in order to sustain life on a planet. 3
- (b) What name is given to planets found outwith our solar system? 1
- (c) State one method of detecting such planets. 1
3. (a) What observation did Edwin Hubble make in the 1920s which lead him to conclude that all matter had, at one time, been tightly packed into a singularity, which then exploded? 1
- (b) What name is given to this explosion? 1
- (c) How old did Hubble's findings suggest the universe to be? 1
- (d) What is the name of the force that brought together the material spewed out by this explosion to form stars and galaxies? 1
4. Some spectral lines of radiation from a distant star are shown below.



The spectral lines of a number of elements are also shown.



Use the spectral lines of the elements shown above to identify which of these elements are present in the distant star. 2

5. When a substance is strongly heated, a whole range of wavelengths is given out in the form of a continuous spectrum. The proportion of each colour depends on how hot the object is. When it starts to glow, an object is red hot. Eventually it may become white hot. Metal workers can judge the temperature of steel by noting its colour. Astronomers can judge the temperature of the surface of stars by noting the colour of the stars.

- (a) The experiment below was carried out to study the effect of temperature on colour. The voltage was adjusted, and the colour of the light produced by the 6 V bulb examined at 2 V, 4 V and 6 V. Copy the table, and predict the colours that would be observed. The first one has been given to you.

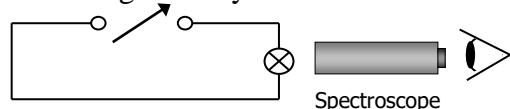

VOLTAGE	BRIGHTEST COLOUR
2 V	Red
4 V	
6 V	

- (b) Study the following list, and put the stars in order of increasing surface temperature: 2
- BETELGEUS E (*orange-red*) RIGEL (*bluish-white*) THE SUN (*yellow*) BARNARD'S STAR (*red*)
- (c) Explain how metal workers can judge the temperature of steel by noting its colour. 1

Total 20 marks