

Home Learning Activities

27.04.20

Literacy

Full Stops

Sounds and Spelling

Your sound for this week is *th*. You can watch a video about this sound here:

[th sound](#)

Here are some tricky words I would like you to practice this week:

she, come, from

There is a sheet to practice your new sound and tricky words below. Or you can practice by writing them yourself on paper, a computer or in the air!

Reading/Writing

Write about what you did at the weekend and draw a picture to match your story. Your story should include something interesting you did and how it made you feel! You can do this on your own paper. If you can't do this, you could record yourself talking about your weekend or make up a story to tell someone about your weekend!

Commas

Sounds and Spelling

Your sound for this week is *o-e*. A magic 'e' at the end of a word turns an 'o' into a capital 'O' sound! Here are your sound and spelling words:

rope, nose, stone, broke, home, more, school, Mrs

Choose of the following spelling activities and complete it for your spelling and sounds words:

- Rainbow spelling
- Spelling pyramids
- Spelling words story
- Spelling sentences
- Silly sentences
- Backwards spelling
- Foreign language spelling

Reading

Choose three characters from a book you have read recently. Then, use information from the story to write clues to describe the characters on the *Guess Who* sheet below. If you can't do this on the sheet, you can give someone spoken clues (and the book) so they can try and guess the character!

Writing

Write a diary entry about your weekend. You can use your own paper or the sheet below! If you can't do this, you could record it onto a mobile phone or computer!

Exclamation Marks

Sounds and Spelling

Your sound this week is *ough* (making a small 'o' sound). Here are your spelling words:

thought, bought, ought, fought, brought, walk, water, picture, once, until

Choose of the following spelling activities and complete it for your spelling and sounds words:

- Rainbow spelling
- Spelling pyramids
- Spelling words story
- Spelling sentences
- Silly sentences
- Backwards spelling
- Foreign language spelling

Reading

Choose three characters from a book you have read recently. Then, use information from the story to write clues to describe the characters on the *Guess Who* sheet below. If you can't do this on the sheet, you can give someone spoken clues (and the book) so they can try and guess the character!

Writing

Write a diary entry about your weekend. You can use your own paper or the sheet below! If you can't do this, you could record it onto a mobile phone or computer!

Full Stops

Trace over the th sounds and the tricky words, and then write them by yourself. Then draw pictures to match the words!

th th th th th th

she come from

three

thumb

Commas and Exclamation Marks

Guess Who

Think about three of the characters from the last story you read. Inside the treasure chest, draw one item that belongs to each character. Then, in the boxes below, write one clue about who each character is. Can an adult correctly guess all of their names and which item belongs to them?

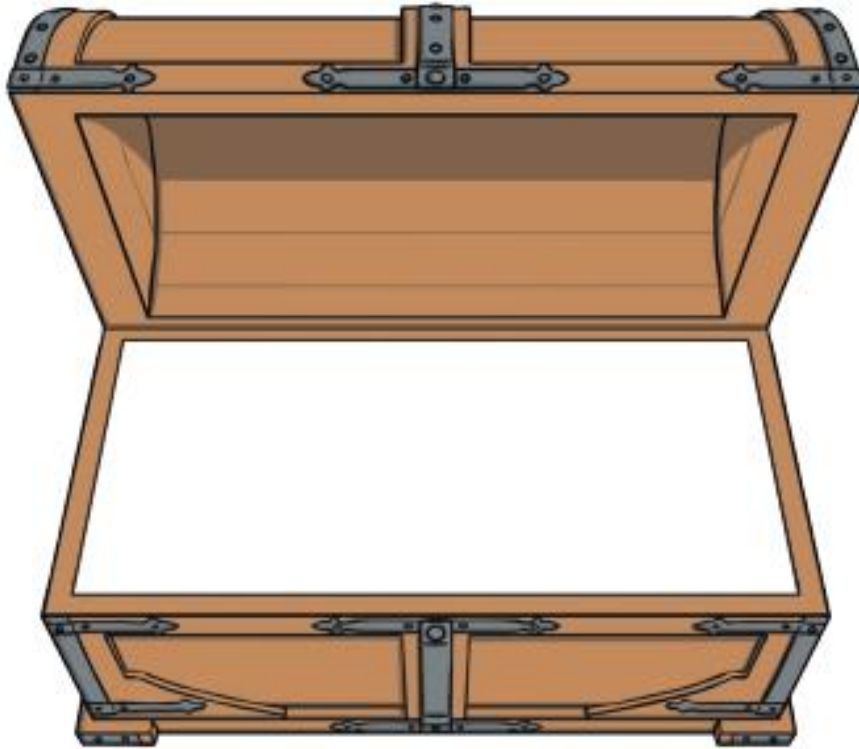

Clue about Character 1:

Clue about Character 2:

Clue about Character 3:

Commas and Exclamation Marks

Dear Diary,

Blank lined area for writing on the top page of the notebook.

Blank lined area for writing on the bottom page of the notebook.

Maths

Copy and complete!

Circles

1. $2 + 2 =$
2. $5 + 5 =$
3. $4 + 4 =$
4. $6 + 6 =$
5. $0 + 0 =$
6. $10 + 10 =$

Complete the shape sheet below!

Here is a Maths game you can play this week:

[Shape Game](#)

You could also go on a shape hunt around your house. How many squares, rectangles, triangles and circles can you find?

Squares

1. $30 - 10 =$
2. $30 - 20 =$
3. $30 - 30 =$
4. $30 - 15 =$
5. $30 - 4 =$
6. $30 - 29 =$
7. $10 \times 8 =$
8. $10 \times 6 =$
9. $10 \times 5 =$
10. $10 \times 10 =$

Complete the shape sheet below by identifying the 2D and 3D shapes!

Here is a shape game you can play this week:

[Shape Game](#)

You could also go on a shape hunt around your house. How many different 2D and 3D shapes can you find?

Triangles

1. $100 - 10 =$
2. $100 - 15 =$
3. $100 - 20 =$
4. $100 - 25 =$
5. $100 - 50 =$
6. $100 - 58 =$
7. $5 \times 7 =$
8. $4 \times 9 =$
9. $3 \times 6 =$
10. $2 \times 11 =$

Complete the shape sheet below by identifying the 2D and 3D shapes!

Here is a shape game you can play this week:

[Shape Game](#)

You could also go on a shape hunt around your house. How many different 2D and 3D shapes can you find?

Circles

Shape

1. Match the word to the shape:

circle



square



triangle



rectangle





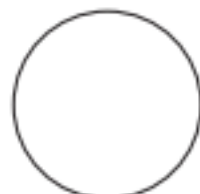
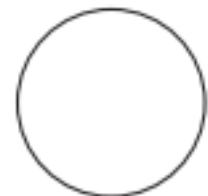
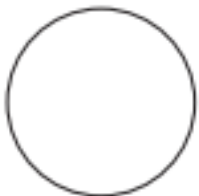



2. Colour:

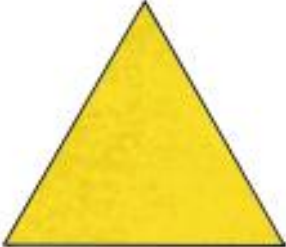

Squares

Identify 2D and 3D shapes

Using the word bank, write the correct name of each 2D and 3D shape below.

			
<input type="text"/>	<input type="text"/>	<input type="text"/>	<input type="text"/>
			
<input type="text"/>	<input type="text"/>	<input type="text"/>	<input type="text"/>



visit [twinkl.com](https://www.twinkl.com)



sphere

cone

rectangular
prism

square

cube

triangle

rectangle

circle

Triangles

Identify 2D and 3D shapes

Using the word bank, write the correct name of each 2D and 3D shape below.

 _____	 _____	 _____	 _____
 _____	 _____	 _____	 _____
 _____	 _____	 _____	 _____
 _____	 _____	 _____	 _____

Word Bank

sphere	kite	square-based pyramid	triangular prism
decagon	triangle	rectangle	rhombus
cone	cylinder	cube	
tetrahedron	circle	rectangular prism	