

DET
Technological Studies
Applied Electronics
Higher

4821

Spring 1999

HIGHER STILL

DET
Technological Studies
Applied Electronics
Higher

Support Materials



Acknowledgements

The Higher Still Development Programme gratefully acknowledges permission granted by the Scottish Qualifications Authority to reproduce questions from the Higher Grade Technological Studies Papers of 1993, 1994, 1995, 1997 and 1998.

Every attempt has been made to gain permission to use extracts from the appropriate copyright owners. The Higher Still Development Programme apologises for any omission which, if notified, it will be pleased to rectify at the earliest opportunity.

CONTENTS

Teacher's Guide

Student Materials

Outcome 1

Outcome 2

Outcome 3

TECHNOLOGICAL STUDIES (HIGHER) - APPLIED ELECTRONICS

Support Materials - Overview

The support materials for Technological Studies courses in Higher Still have been created to specifically address the outcomes and PC in each unit at the appropriate level.

The support materials contain a mixture of formal didactic teaching and practical activities.

The support materials for each unit have been divided into outcomes. This is to facilitate assessment as well as promoting good teaching practice.

The materials are intended to be non-consumable, however it is at the discretion of each centre how to use these materials.

Each package of support materials follows a common format:

1. Statement of the outcome.
2. Statement of *what the student should be able to do* on completion of the outcome.
3. Learning and teaching activities.
4. Sequence of structured activities and assignments.
5. Formal Assessment
 - NAB - assessing knowledge PC.
 - Computer simulation - assessing simulation PC.
 - Practical assignments - assessing practical PC.

It is important to note that the National Assessments have been designed to allow assessment either after each outcome has been completed or as an end of unit assessment when all outcomes have been completed depending on the needs of the centre.

The use of SQA past external paper questions has been used throughout the materials and the further use of these questions is encouraged.

Using past questions provides the opportunity for students to:

- Work at the appropriate level and rigour
- Prepare for external assessment.
- Consolidate teaching and learning.
- Integrate across units.

Homework is a key factor in effective teaching and learning. The use of resources such as *P & N* practice questions in Technological Studies is very useful for homework activities and also in preparation for external assessment.

The use of integrated questions across units is essential in preparation of students for External Assessment.

Support Materials - Content

Outcome 1: Design and construct electronic systems to meet given specifications.

The purpose of this unit of work is to investigate and analyse electronic control systems. The systems use bi-polar and MOSFET's. A range of input and output transducers are investigated and applied. The circuits should be able to control output devices and component protection is considered. Student activities include calculations relating to voltage dividers and transistor gain and construction of electronic control systems.

When you have completed this unit you should be able to:

- State and carry out calculations using the current gain and voltage gain equations.
- Carry out calculations involving bipolar transistor switching circuits
- Carry out calculations involving MOSFET transistor circuits
- Identify and describe the uses of transistors in “push-pull” circuits
- Carry out calculations involving Darlington pair circuits
- Design transistor circuits for a given purpose

Outcome 2: Design and construct electronic systems, based on operational amplifiers, to meet given specifications.

The purpose of this unit of work is to introduce students to operational amplifiers and their applications in electronic systems. Student activities include investigation of op-amps, calculations relating to op-amps and circuit evaluation by simulation and construction.

When students have completed this unit of work they should be able to:

- state the characteristics of an ideal Operational Amplifier;
- identify the various op. amp. configurations;
- carry out calculations involving op. amps.;
- select a suitable op. amp. circuit for a given purpose;
- design op. amp. circuits for a given purpose.

Outcome 3 - Design and construct combinational logic systems to meet given specifications.

The purpose of this unit of work is to introduce students to combinational logic systems. The operational characteristics of logic families are examined and student activities include interpretation of data sheets and construction of combinational logic systems. Analysis of combinational logic systems is achieved by use of truth tables and Boolean algebra. NAND based equivalent circuits are investigated.

When students have completed this unit of work they should be able to:

- Identify single logic gate symbols
- Complete Truth Tables for single logic gates
- Analysis Combinational logic circuits
- Complete Truth Tables for combinational logic circuits
- Simplify combinational logic circuits
- Write a Boolean expression for a given logic circuit
- Determine equivalent circuits made from NAND gates
- Identify differences between the TTL and CMOS families of IC's
- Identify types of logic gates, given pin layout diagrams or IC number (logic gate IC's)
- Correctly 'power up' an IC for uses - either diagrammatically or on breadboard
- Using pin diagrams, select correct IC's and be able to form circuits to given specification.

Resources

The resources listed below are the items that the centre should provide for each student. It may be possible on some occasions for student to share resources, such as multimeters during practical activities, however any activity that will be used to satisfy an assessment requirement must be undertaken individually.

It is expected that centres already presenting Technological Studies at Standard Grade or Higher Level will have the majority of these resources for the current courses.

Circuit Simulation Software

Crocodile Clips	PC/Mac
Oak logic	Acorn
Electronic workbench	PC

Any circuit simulation software that will enable student to create and evaluate electronic systems, op-amp circuits and combinational logic systems would be satisfactory.

General equipment - required for all units

Power supply
Breadboards
Wire for links - 0.6mm solid core insulated wire.
Wire strippers
Digital multimeter
Oscilloscope

Outcome 1

Resistors - 1K
Transistors (NPN various) - BC 107, BFY 51, TIP 31, TIP 32
6 V, 60 mA mes bulb and holder.
MOSFET's (n-channel enhancement only) - MPT3055A, VN10KM, IRF 520
Access to manufacturer data sheets/catalogue/CD - ROM

Outcome 2

Photo diode BPW 41
LDR - ORP12
741 op-amps
Resistors - 560R, 1k, 10k, 22k, 1M, 330 R
Variable resistors - 100k, 47k, 10k, 1k
Strain gauge
Transistors - BFY 51
Thermistors - type 5
Motor - 6 V
Low voltage relays
Apparatus for Practical Assignment 2.1 and 2.3 (02) could be constructed beforehand (see figs. 20 and 25).

Outcome 3

Various IC's (TTL or CMOS) containing common arrangements of two and three input logic gates, 7400, 7402, 7404, 7408

LED's

Resistor values around 370 R.

Logic probe.

Assessment

In most Higher Still courses there are two types of assessment, internal and external

Internal Assessment - this can be conducted in a number of ways:

1. Knowledge based - tested through NAB
2. Practical - tested in class under appropriate conditions.
3. Software simulation (only used in some courses and units)

Internally assessed and is subject to central moderation.

External Assessment - Assessed by means of an external examination

The external examination will provide the basis for grading attainment in course awards and is marked externally.

To gain the award of the course, the student must pass all unit assessments as well as the external assessment.

Recording and retention of evidence

All evidence of performance should be retained by the centre for moderation purposes.

NAB - Test

A record of the candidate's performance must be kept which shows:

- The score achieved if a cut-off score is used.
- When a candidate has achieved an outcome

Practical assessment

A record of the candidate's performance must be kept which shows:

- When circuit simulation is used - a brief description of the circuit being evaluated.
- Whether the candidate has evaluated the circuit correctly.
- Where a circuit is required to be constructed - a brief description of the circuit being constructed.
- Whether the candidate has constructed the circuit to the given specification.

Assessment Summary of each Unit

The following is a summary of the assessment requirements for each outcome.

Outcome 1 - Applied Electronics (Int 2)

1. National Assessment Bank item (Test) - Providing written and graphical evidence for PC a, b and c.
2. Practical activity - providing performance evidence for PC d and e.
The practical activities contained in the support materials will satisfy the assessment requirements for this aspect. Centres should ensure that when candidates are carrying out the practical activity for assessment purposes, appropriate conditions are in place.
Assessment of the computer simulation aspect can be done using the assignments provided in the support materials. Students should be able to evaluate the circuits effectively to satisfy the assessment requirements; this can be done either in writing or as a verbal report to the teacher/lecturer.

Outcome 2 - Applied Electronics (Int 2)

1. National Assessment Bank item (Test) - Providing written and graphical evidence for PC a, b and c.
2. Practical activity - providing performance evidence for PC d and e.
The practical activities contained in the support materials will satisfy the assessment requirements for this aspect. Centres should ensure that when candidates are carrying out the practical activity for assessment purposes, appropriate conditions are in place.
Assessment of the computer simulation aspect can be done using the assignments provided in the support materials. Students should be able to evaluate the circuits effectively to satisfy the assessment requirements; this can be done either in writing or as a verbal report to the teacher/lecturer.

Outcome 3 - Applied Electronics (Int 2)

1. National Assessment Bank item (Test) - Providing written and graphical evidence for PC a, b, c and d.
2. Practical activity - providing performance evidence for PC e and f.
The practical activities contained in the support materials will satisfy the assessment requirements for this aspect. Centres should ensure that when candidates are carrying out the practical activity for assessment purposes, appropriate conditions are in place.
Assessment of the computer simulation aspect can be done using the assignments provided in the support materials. Students should be able to evaluate the circuits effectively to satisfy the assessment requirements; this can be done either in writing or as a verbal report to the teacher.

Recording and retention of evidence

Unit: _____

Outcome : _____

Name	Test		Circuit Simulation	Evaluation	Circuit construction	To given specification	Outcome Achieved
	Cut-off score	Test score	Description of circuit	x or ✓	Description of circuit	x or ✓	x or ✓

TECHNOLOGICAL STUDIES

HIGHER

APPLIED ELECTRONICS

SECTION 1

OUTCOME 1

APPLIED ELECTRONICS

Outcome 1 - Design and construct electronic systems to meet given specifications

When you have completed this unit you should be able to:

- state and carry out calculations using the current gain and voltage gain equations.
- carry out calculations involving bipolar transistor switching circuits
- carry out calculations involving MOSFET transistor circuits
- identify and describe the uses of transistors in “push-pull” circuits
- carry out calculations involving Darlington pair circuits
- design transistor circuits for a given purpose.

Before you start this unit you should have a basic understanding of:

Input and Output transducers;

Voltage divider circuits;

Ohm’s Law - relationship between V and I in a d.c. circuit;

Kirchoff’s laws for current and voltage;

The operational characteristics of various electronic components;

Use of breadboards;

Use of circuit test equipment: multimeter and oscilloscope.

INTRODUCTION

Any electronic system can be broken down into three distinct parts.



AE.H.LO1. fig 1

INPUT transducers convert a change in physical conditions (e.g. temperature) into a change in an electrical property (e.g. voltage) which can then be processed electronically to produce either a direct measurement of the physical condition (temperature in °C) or to allow something to happen at a predetermined level (e.g. switching ON the central heating at 20 °C).

Changes in the resistance of an input transducer must be converted to changes in voltage before the signal can be processed. This is normally done by using a voltage divider circuit.

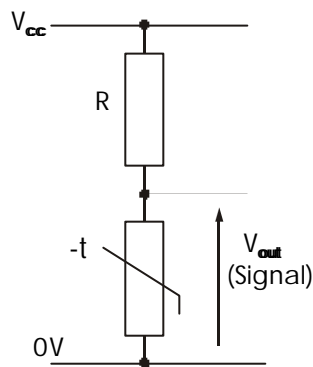

AE.H.O1. fig 2

Voltage divider circuits work on the basic electrical principle that if two resistors are connected in series across a supply, the voltage load across each of the resistors will be proportional to the value of the resistors.

In general, to calculate the voltage over any resistor in a series circuit, we can use the equation:

$$\text{Signal Voltage} = \frac{R}{R_{total}} \times V_{cc}$$

When monitoring physical conditions, one of the resistors in the circuit is an input transducer, the resistance of which will change depending on the physical conditions.

Common Input Transducers

The table gives some examples of common input transducers that you may have met before.

Physical condition to be monitored	Input Transducer	Electrical property that changes
Temperature	Thermistor Thermocouple Platinum Film	Voltage Resistance Resistance
Light	LDR Selenium Cell Photo Diode	Resistance Voltage Current/Resistance
Distance	Slide Potentiometer Variable Transformer Variable Capacitor	Resistance Inductance Capacitance
Force	Strain Gauge	Resistance
Angle	Rotary Potentiometer	Resistance

ASSIGNMENT 1

Calculate the signal voltages produced by the following voltage divider circuits:

a)

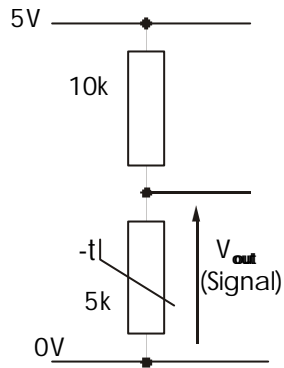

b)

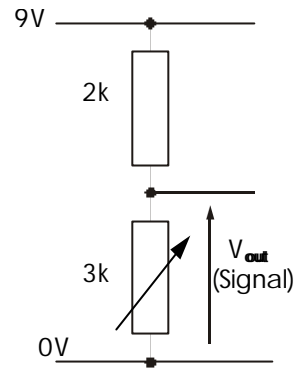

c)

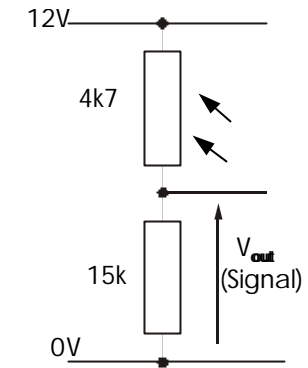

d)

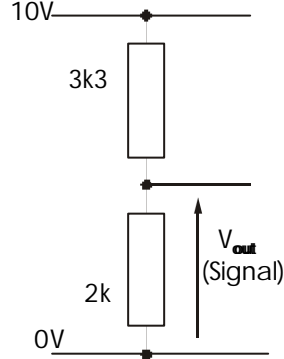

e)

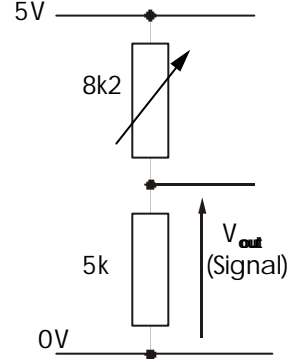

f)

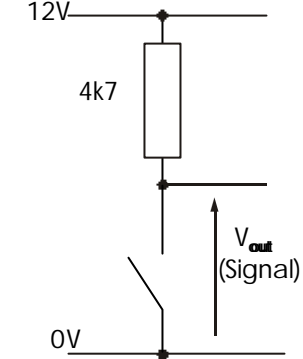

Calculate the size of the unknown resistor required for the given output voltages:

g)

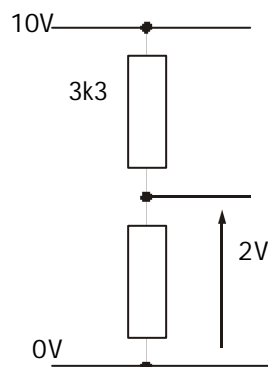

h)

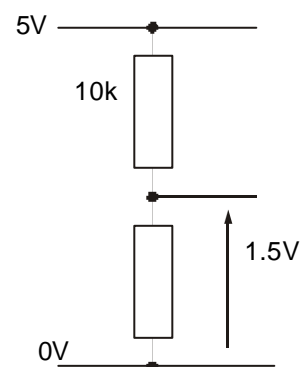

i)

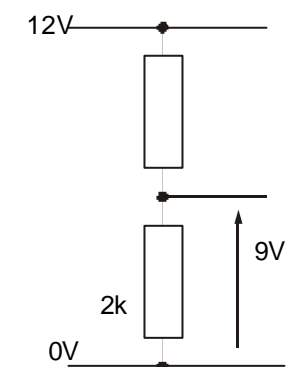

AMPLIFICATION

Input transducers that produce voltage, rarely produce sufficient voltage for most applications. Their outputs have to be amplified.

Amplifying devices are said to be active components, as oppose to non-amplifying components (resistors, capacitors etc.) which are known as passive components. The extra energy required to operate the active component comes from an external power source (battery, transformer, etc.).

The most common active device in an electronic system is the bipolar junction transistor (or simply transistor for short). Two types are available, pnp or npn.

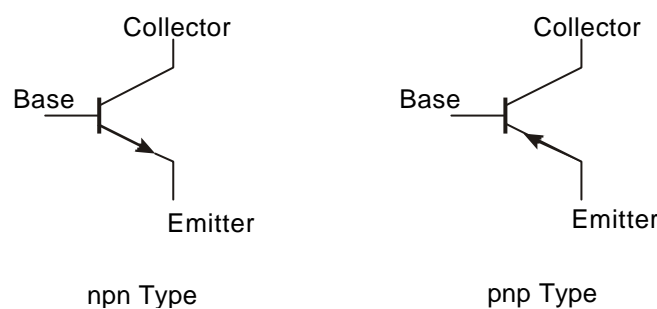

AE.H.O1. fig 3

The transistor has to be connected into circuits correctly. The arrow head on the emitter indicates the direction of "conventional" current flow (positive-to-negative).

Both types of transistors operate in the same way.
For convenience, only the NPN will be considered.
(For PNP transistors, the currents and voltages should be reversed.)

NPN transistors operate when the base is made **Positive**
PNP transistors operate when the base is made **Negative**

TRANSISTOR NOTATION

Subscripts are normally used to indicate specific Voltages and Currents associated with transistor circuits viz.

- I_c - Collector current
- I_b - Base current
- I_e - Emitter current
- V_{CC} - Voltage of supply (relative to ground line)
- V_b - Voltage at the base junction (relative to ground line)
- V_e - Voltage at the emitter junction (relative to ground line)
- V_{ce} - Voltage between the collector and emitter junction
- V_{be} - Voltage between the base and emitter junction
- V_L - Voltage over the load resistor

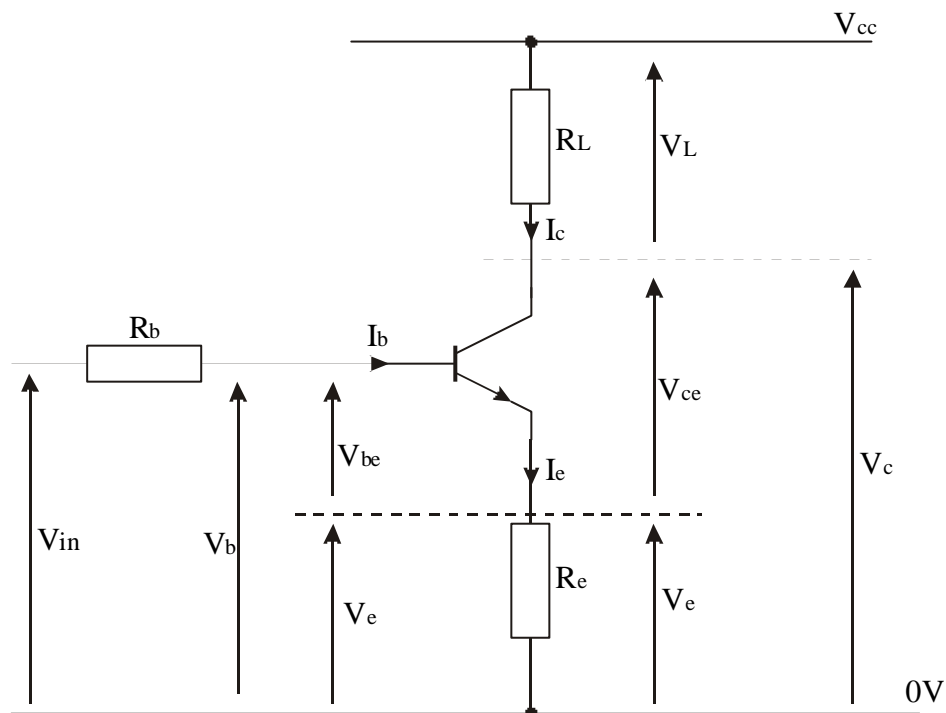

AE.H.O1. fig 4

It can be seen from the diagram that $V_b = V_{be} + V_e$; $V_{CC} = V_L + V_{ce} + V_e$; etc.

The transistor can be used in different modes, the most common of which is the common emitter mode.

(So called because the emitter is common to both input and output signals.)

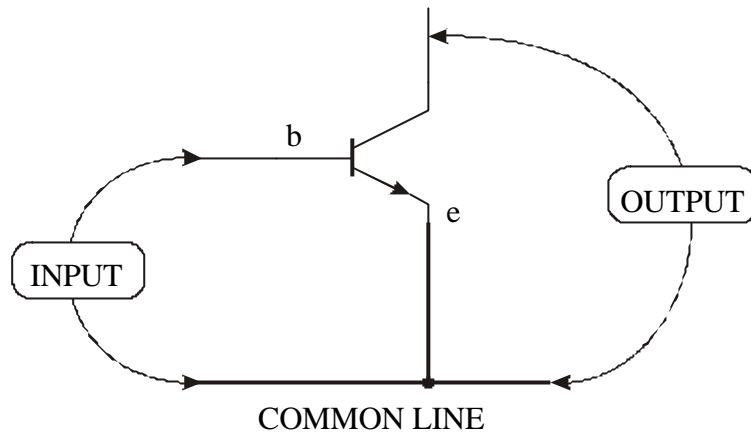

AE.H.LO1. fig 5

In the common emitter mode, a small current flowing between the base and emitter junction will allow a large current to flow between the collector and emitter.

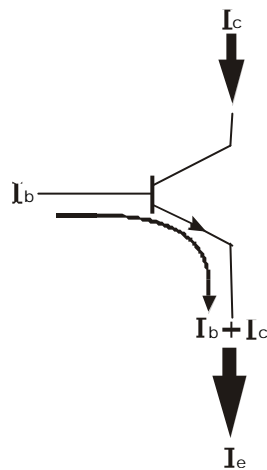

AE.H.O1. fig 6

It can be seen that : $I_e = I_b + I_c$

(Since I_b is usually much smaller than I_c , it follows that I_e is approximately = I_c)

The bipolar transistor is a current-controlled amplifying device (as oppose to a field effect transistor, FET, which is a voltage controlled device).

The current gain (or amplification) of the transistor is defined as the ratio of collector:base currents

$$\text{current gain} = \frac{\text{Collector current}}{\text{Base current}}$$

$$A_i = \frac{I_c}{I_b}$$

The accepted symbol for transistor current gain in this mode is h_{FE}

In practice, the maximum allowable currents will depend on the make of transistor used. These limits can be obtained from manufacturers' data sheets.

Forcing the transistor to carry currents greater than these maxima will cause the transistor to overheat and may damage it.

If the transistor is used to amplify a.c. signals then a change in the base current, ΔI_b will produce a change in the collector current, ΔI_c . The gain is then defined as

$$h_{fe} = \frac{\Delta I_c}{\Delta I_b}$$

(Note: capital "FE" for d.c. circuits, lower case "fe" for a.c. circuits)

For most purposes, h_{FE} can be considered as having the same value as h_{fe}

ASSIGNMENT 1

- a) Calculate the gain of a transistor if the collector current is measured to be 10 mA when the base current is 0.25 mA.
- b) Calculate the collector current through a transistor if the base current is 0.3 mA and h_{FE} for the transistor is 250.
- c) What collector current would be measured in a BC107 transistor if the base current is 0.2 mA and h_{FE} is 100?

TRANSISTOR SWITCHING CIRCUITS

In order to generate a current in the base of the transistor, a voltage must be applied between the base - emitter junction (V_{be}).

It is found that no (or at least negligible) current flows in the base circuit unless V_{be} is above 0.6 Volts.

Increasing the base - emitter voltage further, increases the base current (producing a proportional increase in the collector current).

When the base - emitter voltage reaches about 0.7 V, the resistance between the base emitter junction starts to change such that the base - emitter voltage remains at about 0.7 V. At this point the transistor is said to be saturated. Increasing the base current further has no effect on the collector current. The transistor is fully ON.

It can be assumed that if the transistor is turned ON, $V_{be} = 0.7 \text{ V}$

ASSIGNMENT 2

For each of the circuits shown, calculate V_{be} and state if the transistor is ON or OFF.

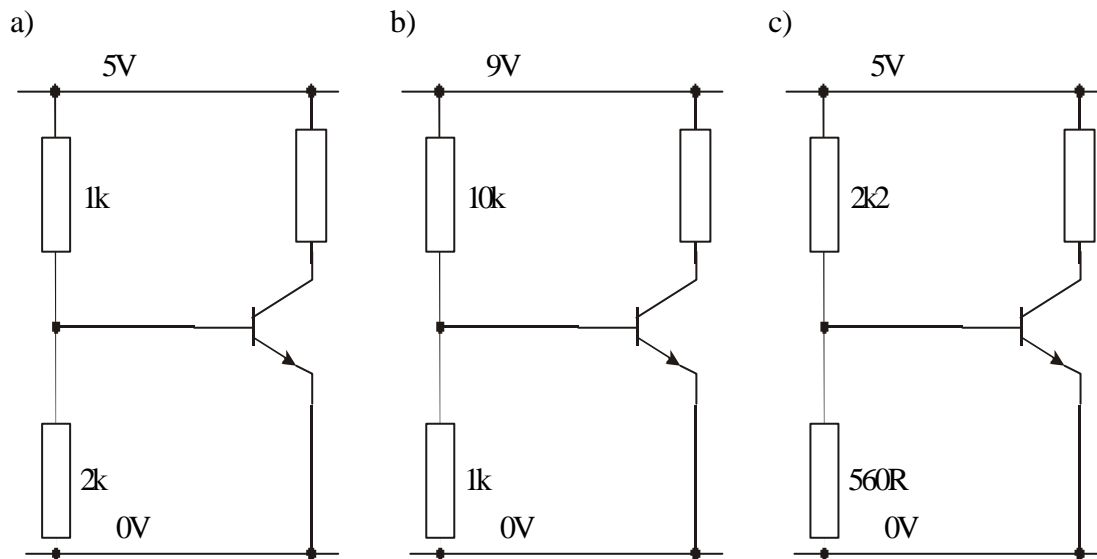

WORKED EXAMPLE

Consider the circuit shown in figure 7 a

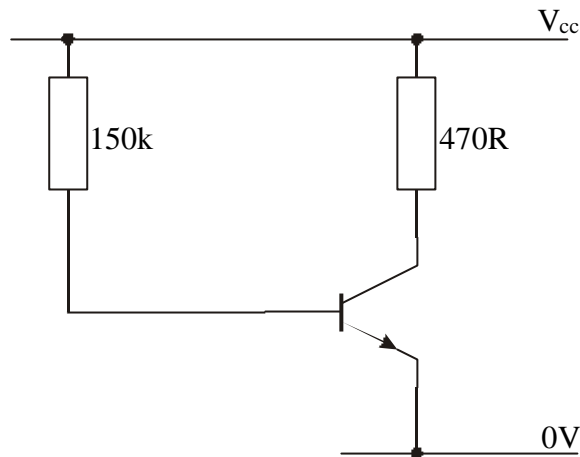

AE.H.LO1. fig 7 a

If the transistor is ON, calculate the collector current and V_{ce} , if $h_{FE}=200$ and $V_{CC} = 9$ Volts

Figure 7 b shows the circuit currents and voltages using standard notation.

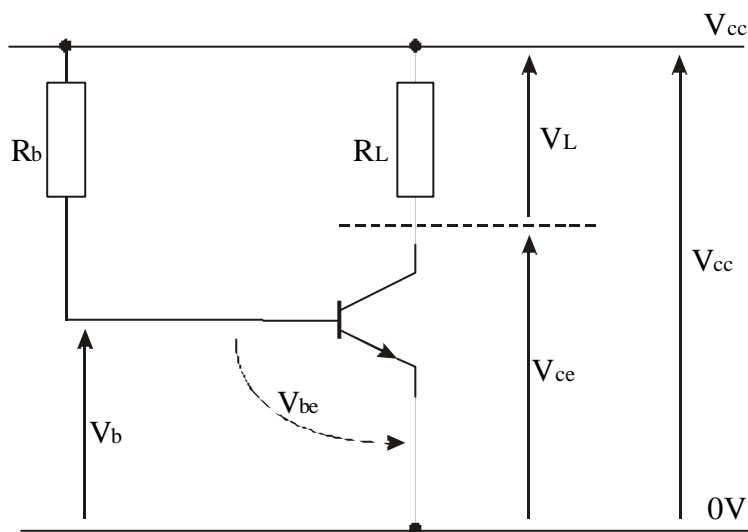

AE.H.LO1. fig 7 b

Step 1

The voltage between the base and emitter junction is always about 0.7 V .
Since the emitter is connected to the ground line (0V), $V_b = 0.7$ V

Step 2

The voltage dropped over the base resistor can then be calculated
Voltage drop = $V_{CC} - V_b = 9 - 0.7 = 8.3$ Volts

Step 3

The base current is calculated using Ohm's law

$$I_b = \frac{V_{dropped}}{R_b} = \frac{8.3}{150k} = 0.00553mA$$

Step 4

I_c is calculated knowing h_{FE}

$$I_c = h_{FE} \times I_b = 200 \times 0.00553 = \underline{11.06 \text{ mA}}$$

Step 5

V_L is calculated using Ohm's law

$$V_L = I_c \times R_L = 11.06 \text{ mA} \times 470 = 5.2 \text{ V}$$

Step 6

V_{ce} is calculated

$$V_{ce} = V_{cc} - V_L = 9 - 5.17 = \underline{3.8 \text{ V}}$$

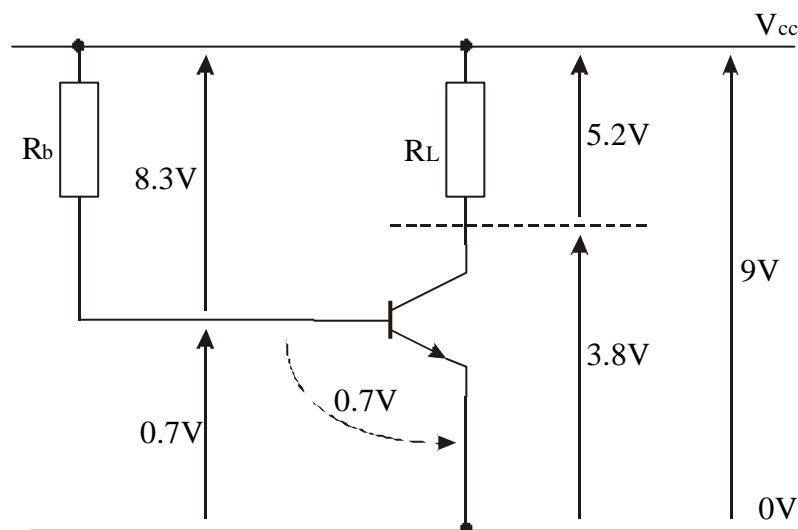

AE.H.LO1. fig 7 c

ASSIGNMENT 3

A 6 V, 60 mA bulb is connected to the collector of a BFY50 transistor as shown.

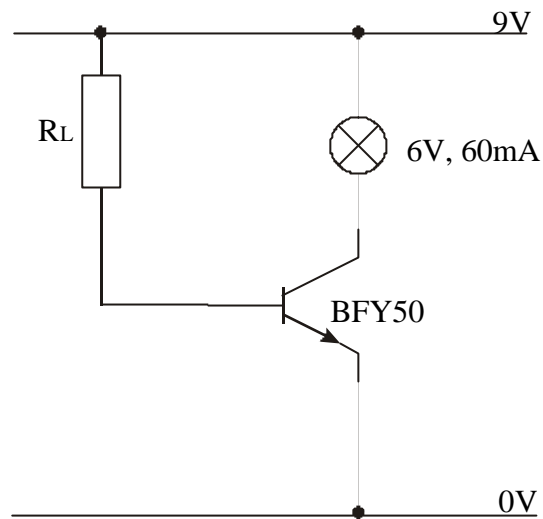

AE.H.LO1. fig 8

If the gain of the transistor is 30, determine the size of the base resistor R_b required to ensure that the bulb operates at its normal brightness.

VOLTAGE AMPLIFICATION

Although the transistor is a current amplifier, it can easily be modified to amplify voltage by the inclusion of a load resistor, R_L , in the collector and/or emitter line.

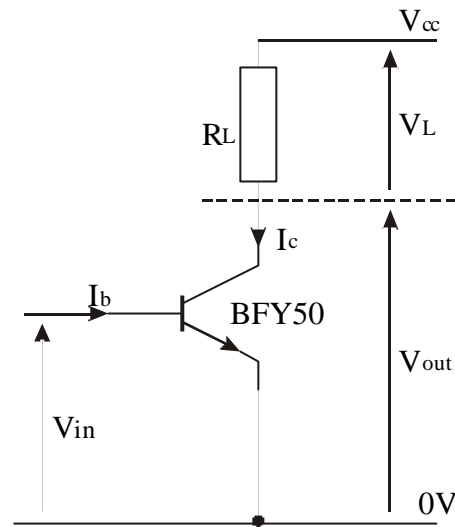

AE.H.LO1. fig 9

Here, applying the voltage V_{in} to the base gives rise to the base current I_b . This in turn causes a proportional increase (depending on the gain) in the collector current I_c .

Since the current through the load resistor (I_c) has increased, the voltage over R_L has increased ($V_L = I_c R_L$) and hence V_{out} has decreased. ($V_{out} = V_{CC} - V_L$)

The Voltage gain of any amplifier is defined as

$$\text{Voltage gain} = \frac{\text{voltage output}}{\text{voltage input}}$$

$$A_v = \frac{V_o}{V_i}$$

WORKED EXAMPLE

Consider the circuit shown in figure 10 a

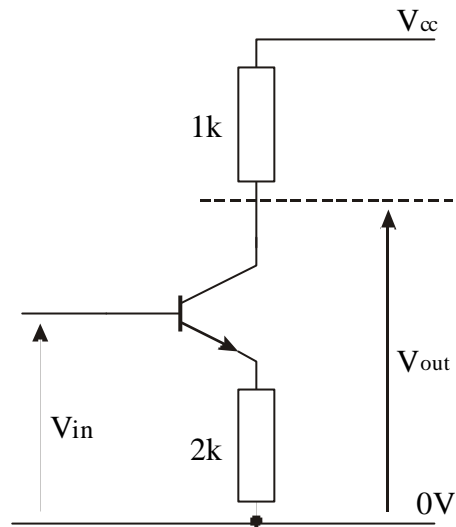

AE.H.LO1. fig 10 a

Calculate the voltage gain of this circuit if $V_{in} = 1.7$ Volt, $h_{FE} = 100$ and $V_{CC} = 6V$

Figure 10 b shows the circuit currents and voltages using standard notation.

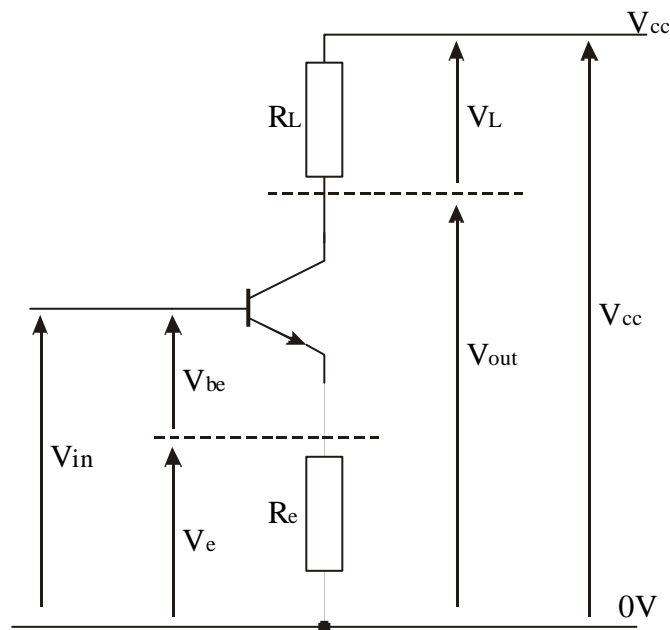

AE.H.LO1. fig 10 b

Step 1

The voltage between the base and emitter junction (V_{be}) is always about 0.7 V hence:
 $V_e = V_{in} - 0.7 = 1.0 \text{ V}$

Step 2

The current through R_e is calculated using Ohm's law

$$I_e = \frac{V_e}{R_e} = \frac{1.0}{2k} = 0.5mA$$

Step 3

For this value of h_{FE} , I_b will be small compared to I_c (one hundredth of the value), hence, $I_c = I_e$

Step 4

The voltage over the load resistor (R_L) is calculated using Ohm's law

$$V_L = I_c \times R_L = 0.5 \text{ mA} \times 1k = 0.5 \text{ V}$$

Step 5

The output voltage can now be calculated from

$$V_{out} = V_{CC} - V_L = 6 - 0.5 = 5.5 \text{ V}$$

Step 6

The voltage gain is therefore

$$A_v = \frac{V_o}{V_i} = \frac{5.5}{1.7} = 3.2$$

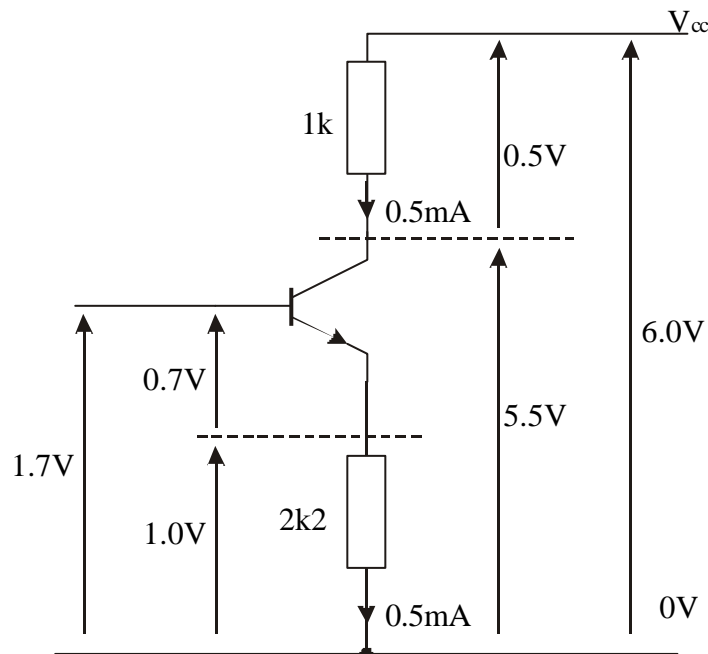

AE.H.LO1. fig 10 c

ASSIGNMENT 4

A transistor of very high current gain is connected to a 9 Volt supply as shown.

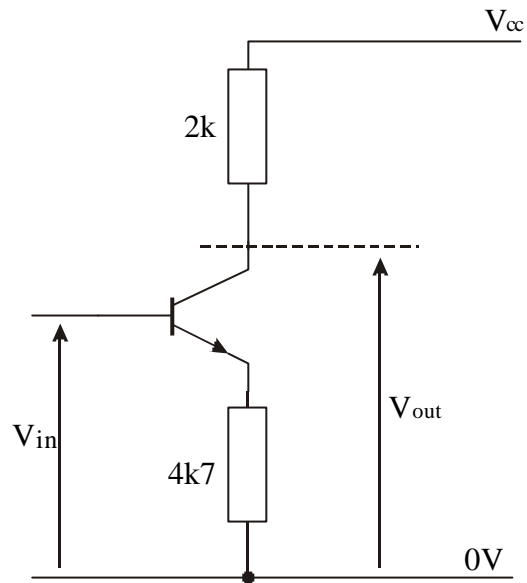

AE.H.LO1. fig 11

Determine the output voltage and the voltage gain when an input of 3 Volts is applied.

PRACTICAL CONSIDERATIONS

Care must be taken to ensure that the maximum base current of the transistor is not exceeded.

When connecting the base of a transistor directly to a source, a base protection resistor should be included. This will limit the maximum current into the base.

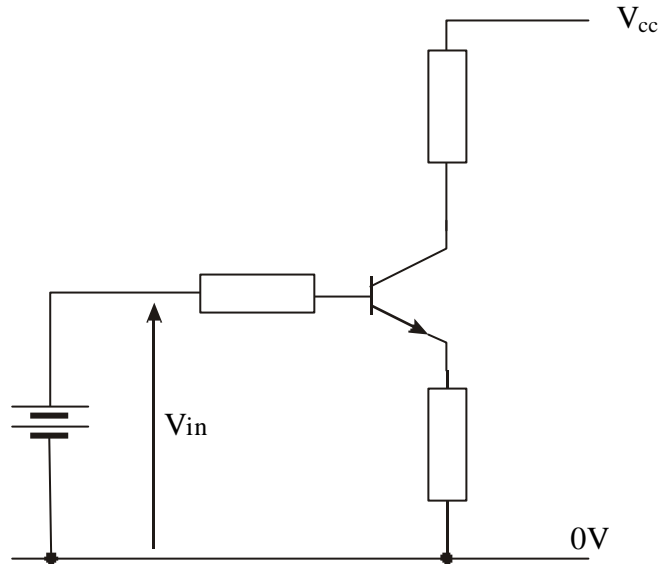

AE.H.LO1. fig 12

If the transistor is to be connected to a potential divider circuit then the maximum possible current into the base will depend on R_1 (see fig 13)

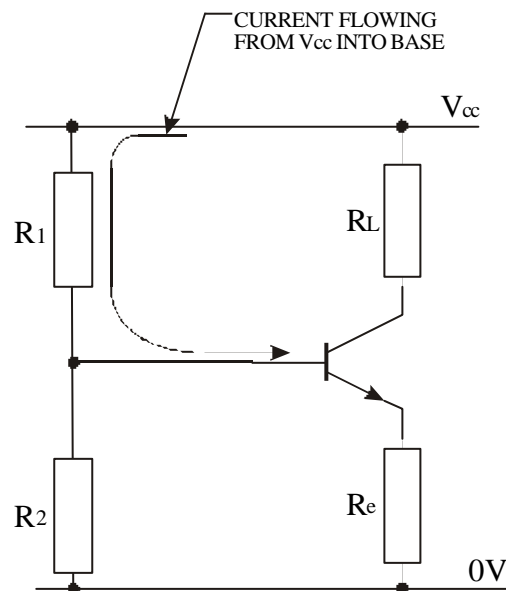

AE.H.LO1. fig 13

The maximum possible current through R_1 (and hence into the base) would be $= \frac{V_{CC}}{R_1}$

hence if R_1 is large, the base current will be small and therefore no damage should occur. If R_1 is small (or has the capability of going small e.g. using a variable resistor as R_1), a protection resistor must be included in the base.

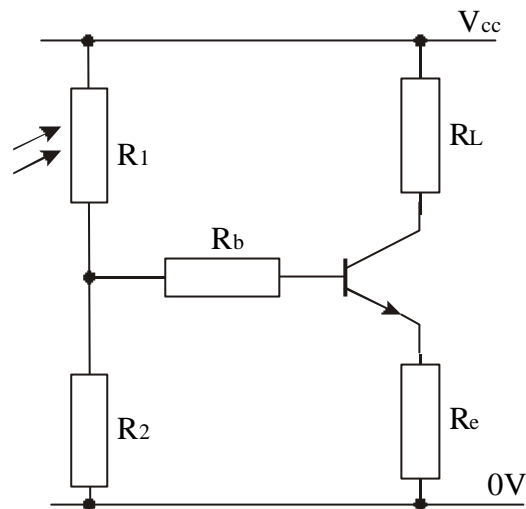

AE.H.LO1. fig 14 a

If $R_1 = 0$, the maximum possible current into the base $= \frac{V_{CC}}{R_b}$ hence R_b can be calculated if V_{CC} and the maximum allowable base current is known.

Most data sheets will quote the maximum collector current and h_{FE} and so the maximum allowable base current can be calculated.

ASSIGNMENT 5

Assume $I_{C(\max)}$ for the transistor shown in figure 14 b is 100 mA and h_{FE} is 200.

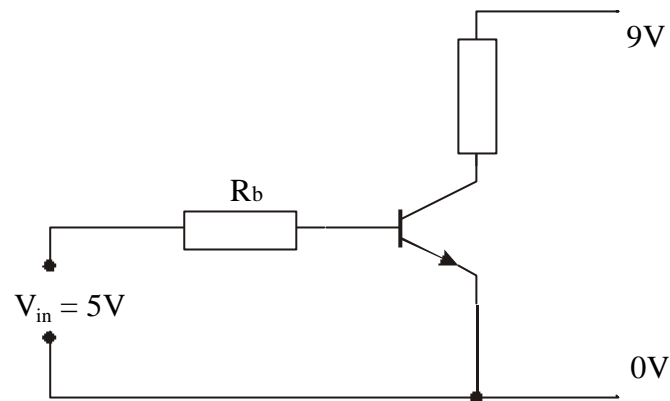

AE.H.LO1. fig 14 b

Calculate:

- the maximum allowable base current.
- the size of protection base resistor required (remembering $V_{be} = 0.7V$, and $R = V/I$)

Circuit Simulation Software

It is possible to use circuit simulation software such as ‘Crocodile Clips’ to investigate electric and electronic circuits. Circuit simulation is widely used in industry as a means of investigating complex and costly circuits as well as basic circuits.

Circuit simulators make the modelling and testing of complex circuits very simple. The simulators make use of libraries of standard components along with common test equipment such as voltmeters, ammeters and oscilloscopes.

Using Crocodile Clips or another similar software package construct and test the following circuits.

N.B. These circuits investigate the need for protection in order to avoid damage. DO NOT construct these circuits using “real” components.

1. Using the simulation software, construct the circuit shown in figure 15 using a 5 V supply.

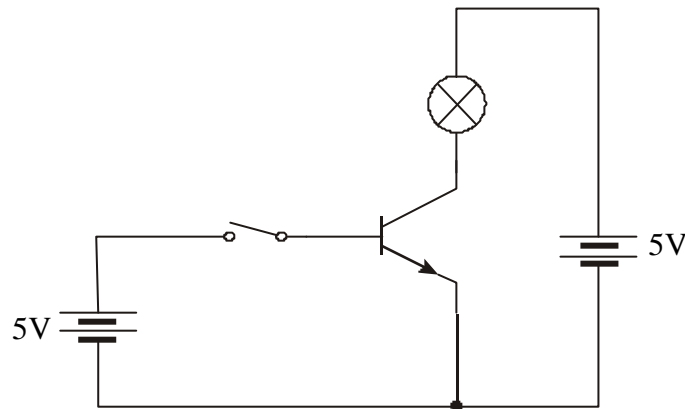

AE.H.LO1. fig 15

Switch on and see what happens.

Now insert a 10k base protection resistor (figure 16) and see what happens when you switch on now.

Use the simulation to determine the smallest value of resistor required to protect this transistor.

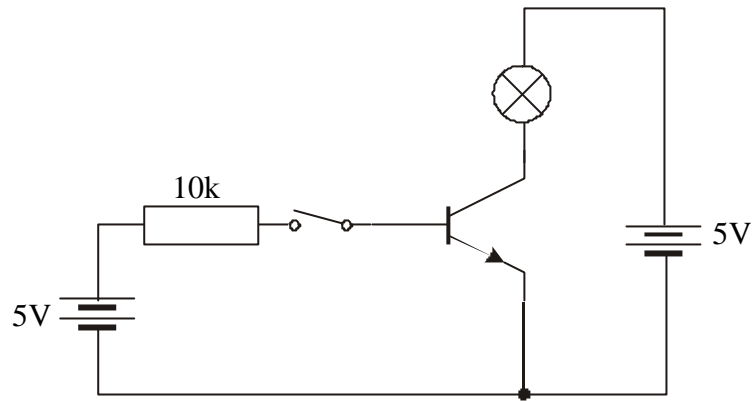

AE.H.LO1. fig 16

2. Construct the circuit shown in figure 17 using 5 Volt supplies.

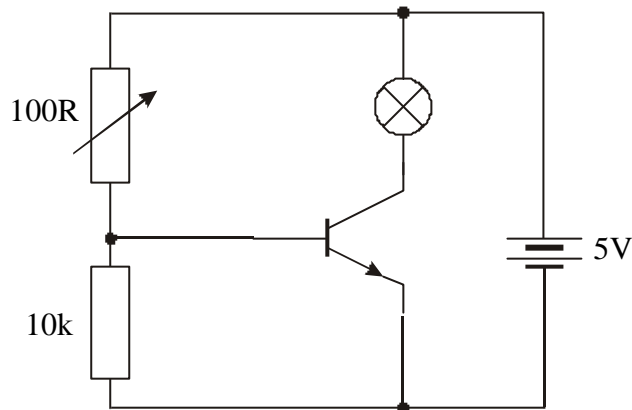

AE.H.LO1. fig 17

See what happens when you reduce the size of the variable resistor.
Now re-design the circuit to include a base protection resistor.

TRANSDUCER DRIVER CIRCUITS

Output transducers can require large currents to operate them. Their resistance tends to be small.

Currents derived from input transducers, either directly, or from using a voltage divider circuit tend to be small.

A transistor circuit can be used to drive the output transducer.

A small current into the base of the transistor will cause a large current to flow in the collector/ emitter circuit into which the output transducer is placed (see fig 18).

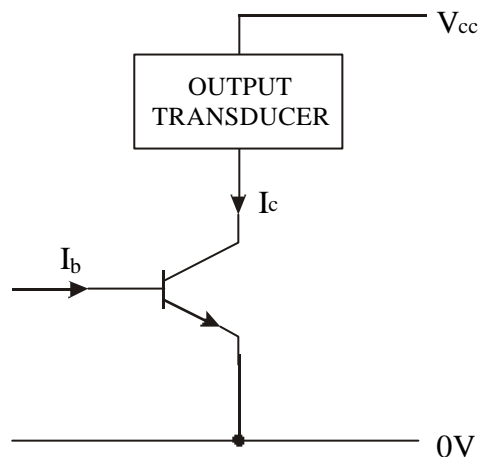

AE.H.LO1. fig 18

The base current is derived from applying a voltage to the base of the transistor.

If the voltage between the base - emitter junction (V_{be}) is less than 0.6 V, the transistor will not operate, no current will flow in the emitter/collector circuit and the output transducer will be OFF.

If V_{be} is 0.7 V (or forced above 0.7 V), the transistor will operate, a large current will flow in the emitter/collector circuit and the transducer will switch ON.

If V_{be} lies between 0.6 and 0.7, the transistor acts in an analogue manner and this may result in the output transducer hovering around an on and off state.

ASSIGNMENT 6

An NTC thermistor is used in the circuit shown in figure 19 to indicate if the temperature falls too low. When the bulb is on the current through it is 60 mA.

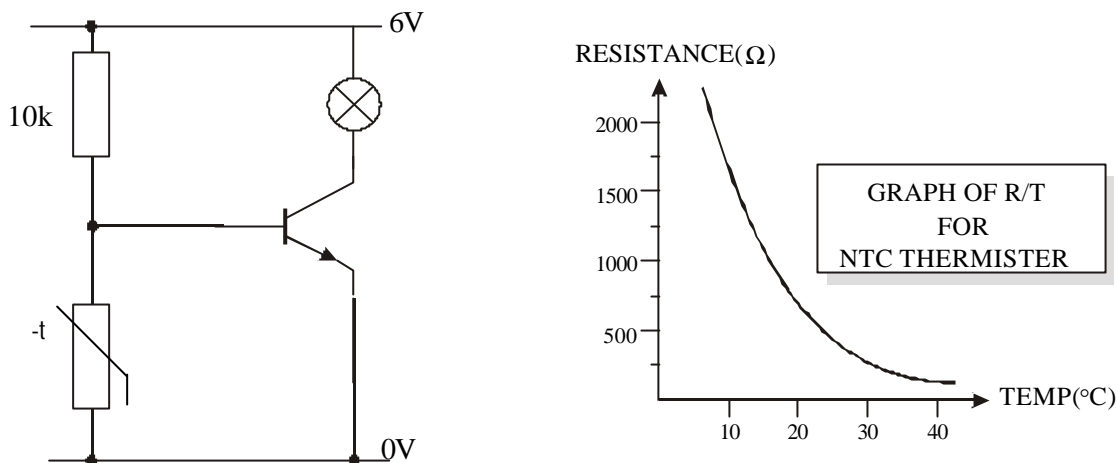

AE.H.LO1. fig 19

- If h_{FE} for the transistor is 500, determine the base current required to switch on the bulb.
- What voltage is required at the base of the transistor to ensure that the bulb indicator switches ON?
- Calculate the voltage dropped over, and hence the current through the 10 k resistor.
- Calculate the current through the thermistor and the resistance of the thermistor when the bulb is ON?
- Using the information on the graph, determine at what temperature the bulb would come ON.
- How could the circuit be altered so that the bulb would come on at a different temperature?
- How could the circuit be altered so that the bulb would come when the temperature is too high?

N.B. The voltage between the base and emitter junction always remains at around 0.7 V even if the input voltage is increased. This occurs because the base/emitter resistance decreases. This in turn causes an increase in the base current (with no increase in collector current since the transistor is already turned fully ON) and as we have already seen, circuits of the type shown above could damage the transistor. It is normal practice to include a resistor in either the base or/and emitter line in order to limit the base current. In either case, the base - emitter voltage will be around 0.7 V.

For the circuit shown in figure 20 a, the voltage divider circuit provides an input voltage of 3.0 V. However when this is connected to a transistor as in figure 20 b, the base/emitter resistor (R_{be}) acts a parallel resistor with the bottom 1 k and this causes the voltage to fall to 0.7 V.

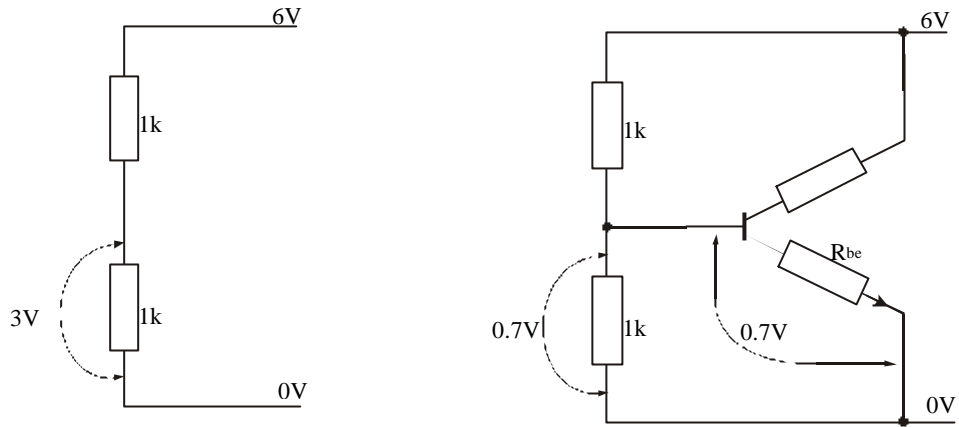

AE.H.LO1. fig 20 a and b

Placing a resistor in either the base or emitter circuit will limit the base current.
 V_{be} always being about 0.7 V.

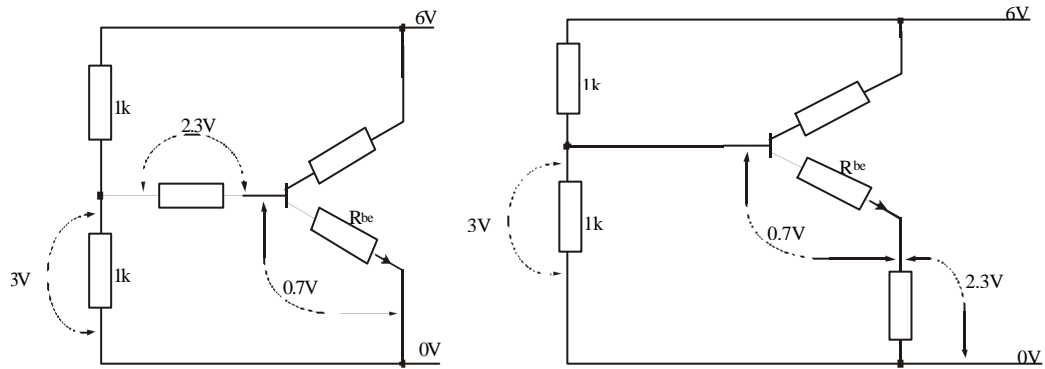

AE.H.LO1. fig 20 c and d

WORKED EXAMPLE

For the circuit shown in figure 20 e, $V_{CC} = 12V$ and $h_{FE} = 50$. Calculate: a) the base current; b) the collector current; and d) V_{out}

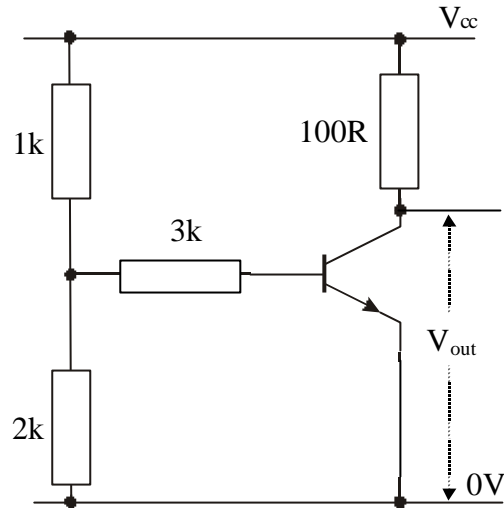

AE.H.LO1. fig 20 e

Step 1

Assume $V_{be} = 0.7V$

The base-emitter junction acts as a resistor (R_{be}) in series with the 3k. R_{be} and the 3k are in parallel with the 2k

Step 2

Redraw the input circuit using subscripts to indicate the various currents and voltages.

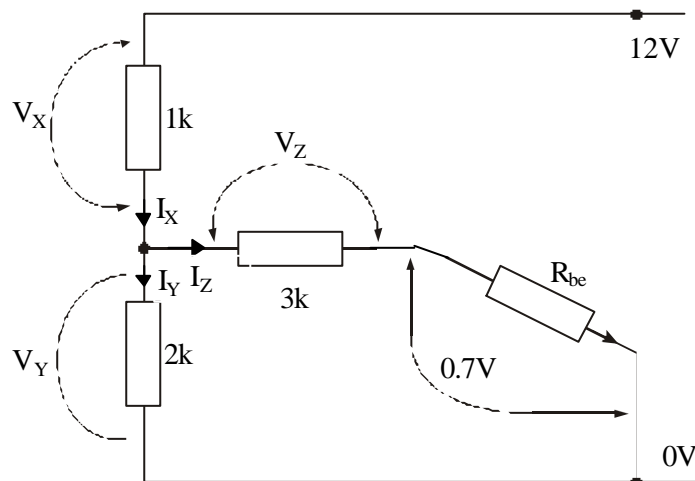

AE.H.LO1. fig 20 f

Step 3

Applying Kirchoff's laws to the circuit, it can be seen that:

$$V_X + V_Y = 12 \text{ [equation 1]}$$

$$V_Z + 0.7 = V_Y \text{ [equation 2]}$$

$$I_X = I_Y + I_Z \text{ [equation 3]}$$

N.B. $I_Z = I_b$, however the current through the emitter will not be I_Z since $I_e = I_b + I_c$ (which we have omitted from the diagram)

Step 4

Using Ohm's law:

$$I_X = V_X/1k \quad I_Y = V_Y/2k \quad I_Z = V_Z/3k$$

Substituting into equation 3 we get:

$$\begin{aligned} \frac{V_X}{1k} &= \frac{V_Y}{2k} + \frac{V_Z}{3k} \\ \frac{V_X}{1k} &= \frac{3V_Y + 2V_Z}{6k} \\ \frac{6kV_X}{1k} &= 3V_Y + 2V_Z \\ 6V_X &= 3V_Y + 2V_Z \text{ [equation 4]} \end{aligned}$$

Step 5

Using equations 1,2 and 4, we now have 3 equations and 3 'unknowns'. We can therefore determine the 'unknowns' by using simultaneous equations.

$$\text{From [1]} \quad V_X = 12 - V_Y$$

$$\text{From [2]} \quad V_Z = V_Y - 0.7$$

Substituting these into [4] we get:

$$6(12 - V_Y) = 3V_Y + 2(V_Y - 0.7)$$

$$72 - 6V_Y = 3V_Y + 2V_Y - 1.4$$

$$11V_Y = 73.4$$

$$V_Y = 73.4/11 = \underline{6.6 \text{ Volts}}$$

Substituting into [1], we get:

$$V_X = 12 - V_Y = 5.4 \text{ Volts}$$

Substituting into [2], we get:

$$V_Z = V_Y - 0.7 = 5.9 \text{ Volts}$$

Step 6

Since R_{be} is in series with the 3k, $I_b = I_Z$

$$I_Z = V_Z / 3k = 5.9 / 3k = 1.9 \text{ mA}$$

Hence $I_b = \underline{1.9 \text{ mA}}$

Step 7

Knowing h_{FE} , I_c can be calculated:

$$I_c = h_{FE} \times I_b = 50 \times 1.9 \text{ mA} = \underline{95 \text{ mA}}$$

Step 8

Using Ohm's law, the voltage over the load resistor can be calculated:

$$V_L = I_c R_L = 95 \text{ mA} \times 100 = 9.5 \text{ Volts}$$

Step 9

V_{out} can be calculated:

$$V_{out} = 12 - 9.5 = \underline{2.5 \text{ Volts}}$$

ASSIGNMENT 7

1. The two circuits shown below are constructed using transistors of $h_{FE} = 100$. For each of the circuits, calculate the base current and the output voltage.

a)

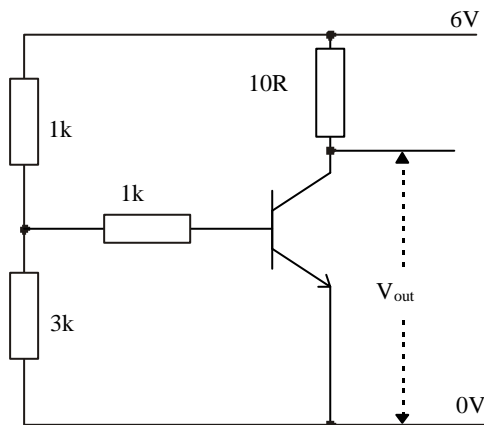

b)

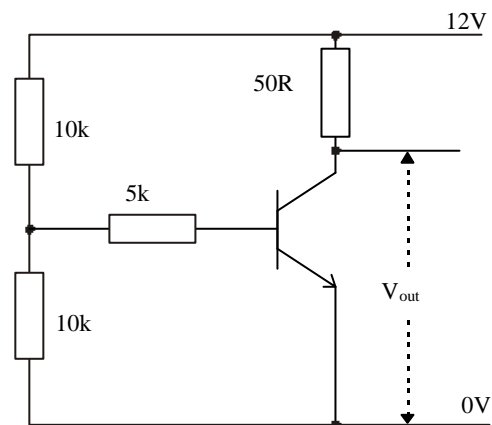

2. For each of the circuits shown below, calculate:
 i) the emitter voltage; ii) the emitter current; iii) the base current

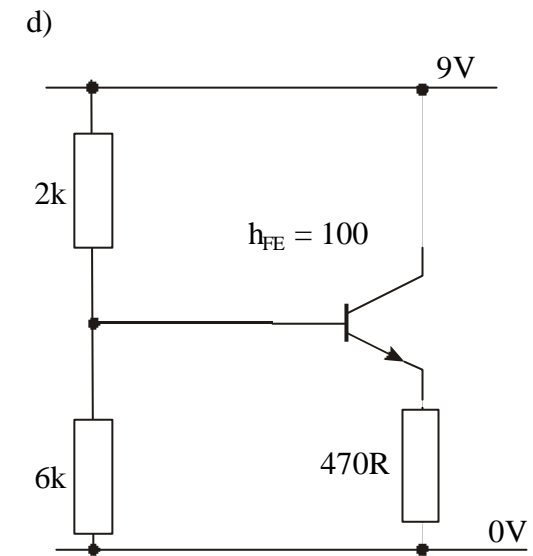
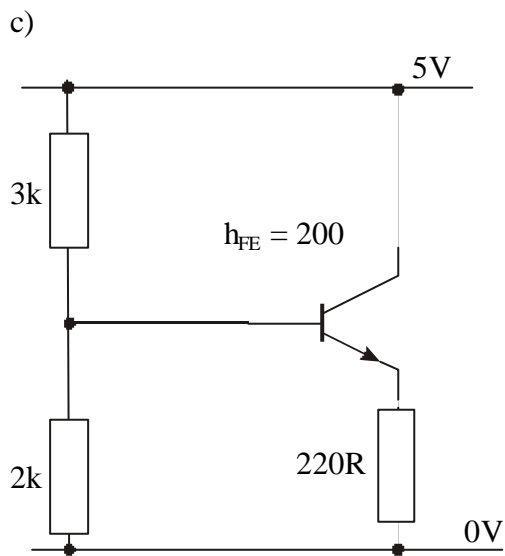
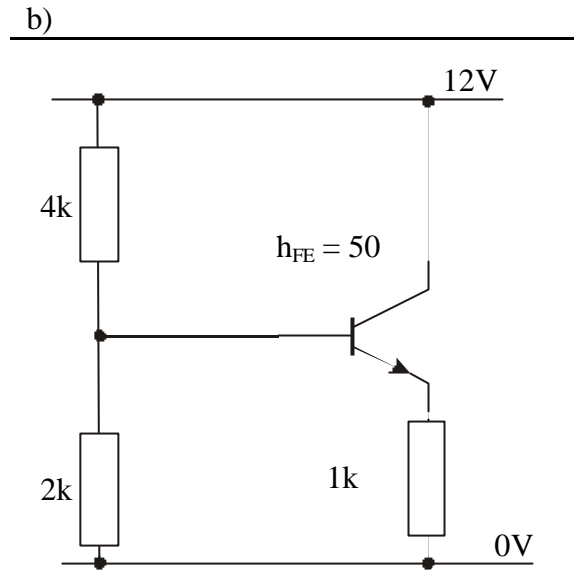
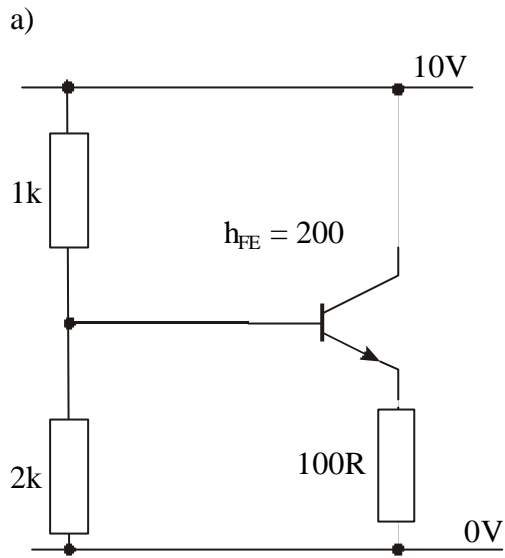

AE.H.LO1. fig 20 g

DRIVING LARGE LOADS

In some circumstances, the current (or voltage) required to operate an output transducer may be too large for a transistor to handle e.g. for heating elements, heavy motors or for machines operating from the mains supply, etc.

In these circumstances, the transistor circuit can be used to drive a relay. The contacts of the relay are then used in a separate circuit to operate the output transducer. See figure 21

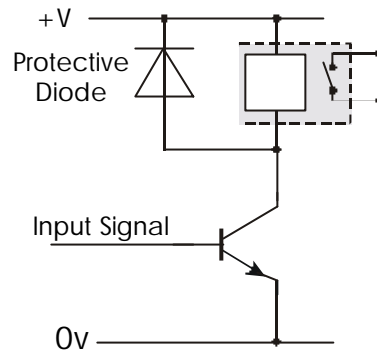

AE.H.LO1. fig 21

For the circuit shown in figure 21, when the transistor is switched on, current flowing through the collector causes the coil in the relay to become an electromagnet, this pulls the contacts closed and completes the circuit to the motor.

The diode protects the transistor when the relay switches off since large "back" voltages can be produced.

The Darlington pair

In order to obtain higher gains, more than one transistor can be used, the output from each transistor being amplified by the next (known as cascading).

Increasing the gain of the circuit means:

1. the switching action of the circuit is more immediate;
2. a very small base current is required in switching;
3. the input resistance is very high.

A popular way of cascading two transistors is to use a Darlington pair as shown in figure 22 (Named after the person that first designed the circuit)

The Darlington pair

In order to obtain higher gains, more than one transistor can be used, the output from each transistor being amplified by the next (known as cascading).

Increasing the gain of the circuit means:

1. the switching action of the circuit is more immediate;
2. a very small base current is required in switching;
3. the input resistance is very high.

A popular way of cascading two transistors is to use a Darlington pair as shown in figure 22 (Named after the person that first designed the circuit)

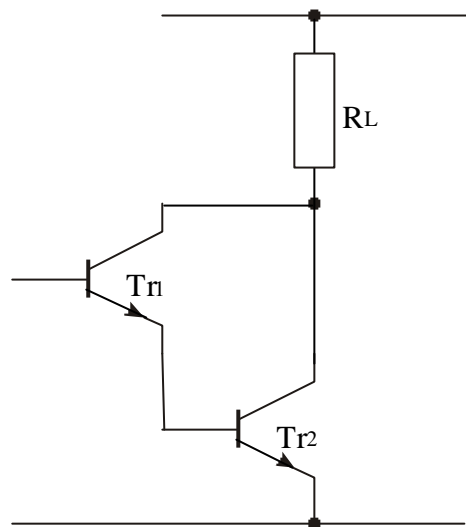

AE.H.LO1. fig 22

The current gain of the "pair" is equal to the product of the two individual h_{FE} 's.
e.g. if two transistors, each of gain 50 are used, the overall gain of the pair will be $50 \times 50 = 2500$

$$A_I = h_{FE1} \times h_{FE2}$$

Because of the popularity of this circuit design, it is possible to buy a single device already containing two transistors (see fig 23)

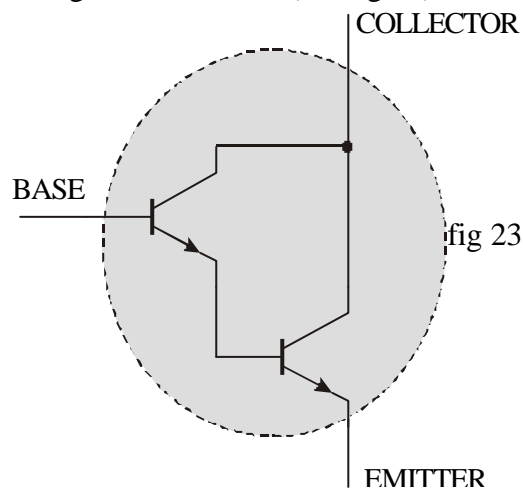

AE.H.LO1. fig 23

In a Darlington pair, both transistors have to be switched on since the collector-emitter current of Tr_1 provides the base current for Tr_2 . In order to switch on the pair, each base-emitter voltage would have to be 0.7V.

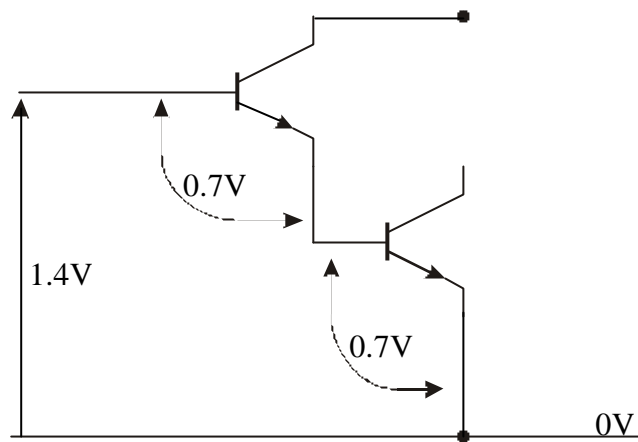

AE.H.LO1. fig 24

The base-emitter voltage required to switch on the pair would therefore have to be 1.4V.

WORKED EXAMPLE

For the Darlington pair shown in figure 25, calculate:

- the gain of the pair;
- the emitter current;
- the base current.

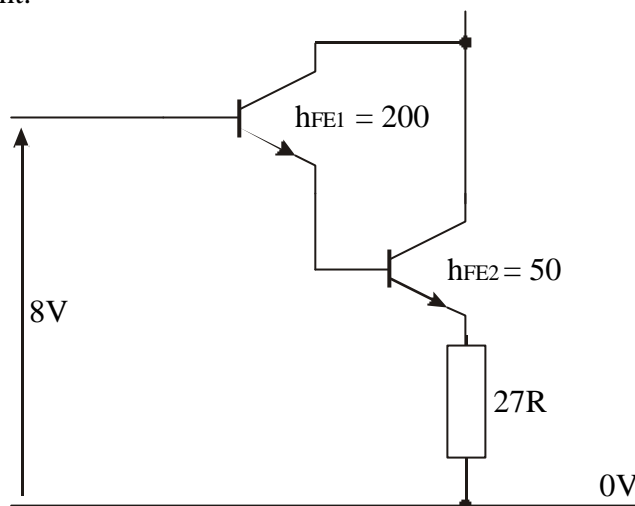

AE.H.LO1. fig 25

Step 1

the overall gain = product of the individual gains

$$A_i = h_{FE1} \times h_{FE2} = 200 \times 50 = 10000$$

Step 2

the voltage over the load resistor must be the input voltage to the base minus the base-emitter voltage required to switch on the pair

$$V_L = V_{in} - V_{be} = 8 - 1.4 = 6.6 \text{ V}$$

Step 3

the emitter current in the load resistor can be obtained from Ohm's law

$$I_e = \frac{V_L}{R_L} = \frac{6.6}{27} = 0.244 \text{ A}$$

Step 4

since the gain is very high, $I_c = I_e$

the gain for any transistor circuit = I_c/I_b

hence knowing I_c and A_i , I_b can be calculated

$$A_i = \frac{I_c}{I_b} \Rightarrow I_b = \frac{I_c}{A_i} = \frac{0.244}{10000} = 24.4 \times 10^{-6} \text{ A}$$

ASSIGNMENT 8

For the circuit shown in figure 22, the gain of Tr_1 is 150, the gain of Tr_2 is 30.

Calculate:

- the overall gain of the Darlington pair;
- the base current required to give a current of 100 mA through the load resistor.

PRACTICAL ASSIGNMENT 1

Water level sensing

In many control situations, it is important to be able to "sense" when a particular water level has been attained, e.g. in filling a washing machine.

Water conducts electricity to a certain extent.

Two wires acting as probes can be used as an input sensor, when no water is present, the resistance is very high (almost infinity), when water is present, the resistance lowers.

Construct the circuit shown below.

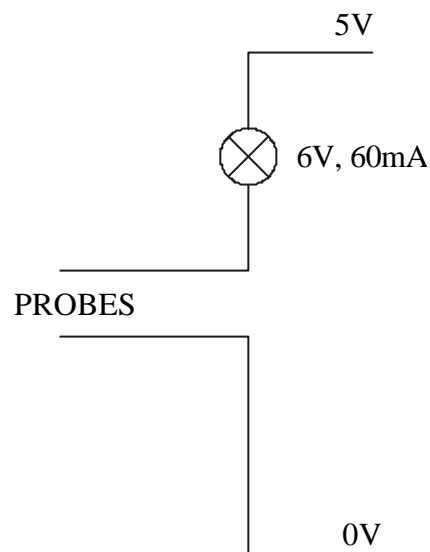

AE.H.LO1. fig 26

Place the two "probes" into water.

If electricity does flow through the water, suggest why the bulb does not light.

A single transistor can be used to amplify the current passing through the water as shown in figure 27.

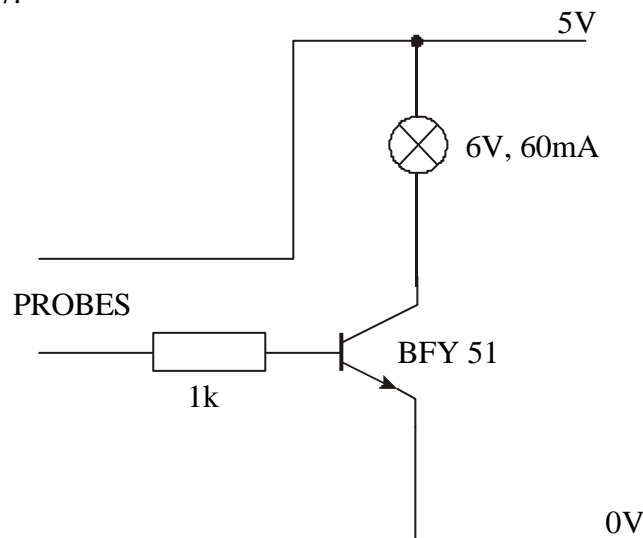

AE.H.LO1. fig 27

Suggest a reason for including the 1 k resistor in this circuit.

Further amplification can be included by using two transistors connected as a Darlington pair as shown in figure 28.

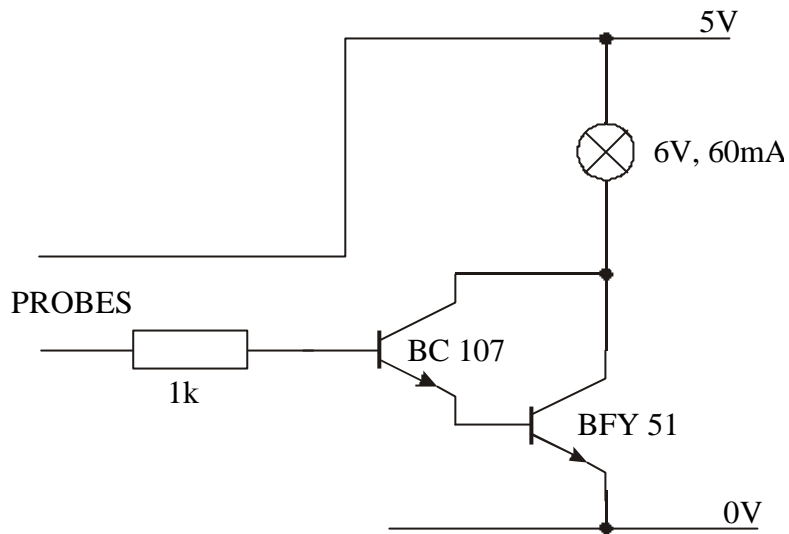

AE.H.LO1. fig 28

Construct the circuits shown in figures 27 and 28, compare their operation and cost.

Suggest how the circuit could be altered to provide an audible warning that a water level was too high, include a circuit diagram and suggest a practical application.

Suggest how the circuit could be altered to indicate if the water level is too low.

MOSFETS

Although the base current in a transistor is usually small ($< 0.1 \text{ mA}$), some input devices (e.g. a crystal microphone) may be limited in their output. In order to overcome this, a Field Effect Transistor (FET) can be used.

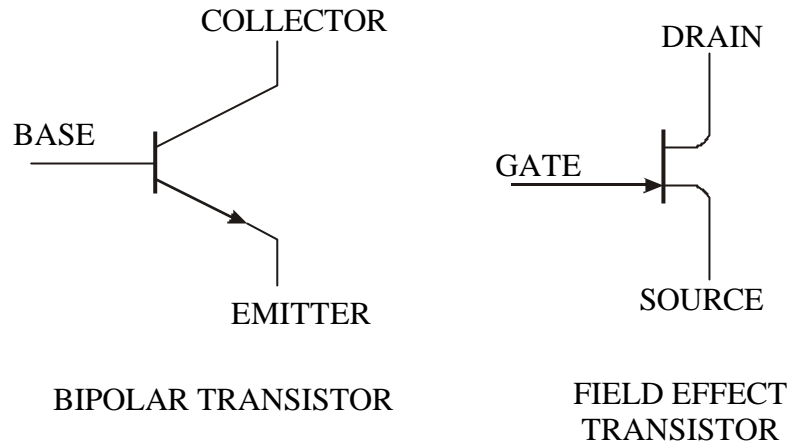

AE.H.LO1. fig 29

Applying a voltage to the Gate connection allows current to flow between the Drain and Source connections.

This is a Voltage operated device. It has a very high input resistance (unlike the transistor) and therefore requires very little current to operate it (typically $10\text{-}12 \mu\text{A}$).

Since it operates using very little current, it is easy to destroy a FET just by the static electricity built up in your body.

FET's also have the advantage that they can be designed to drive large currents, they are therefore often used in transducer driver circuits.

Two different types of FET's are available:
JFET (Junction Field Effect Transistor); and
MOSFET (Metal Oxide Semiconductor Field Effect Transistor).

All FET's can be N-channel or P-channel.
MOSFET's can be "depletion type" or "enhancement type".

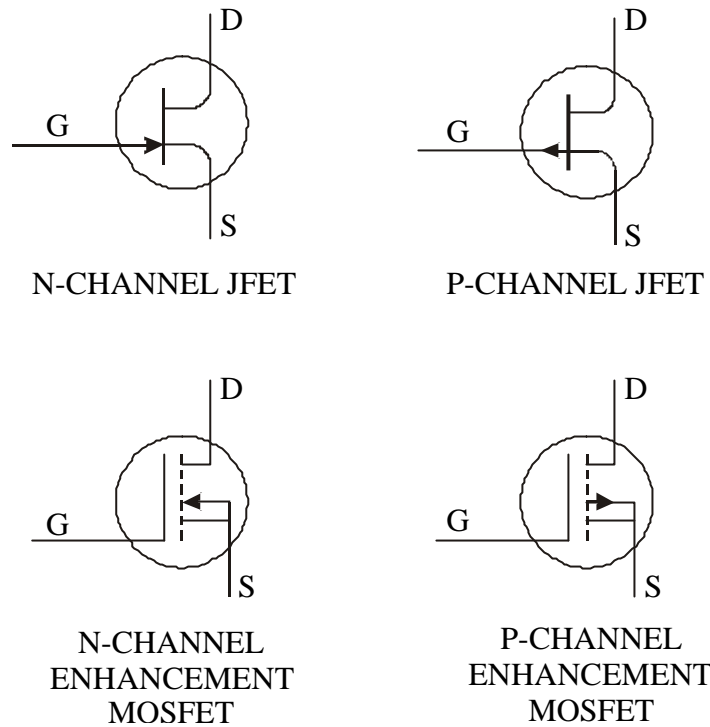

AE.H.LO1. fig 30

The simplicity in construction of the MOSFET means that it occupies very little space. It can also be designed to be used as a resistor or capacitor. Because of its small size, many thousands of MOSFET's can easily be incorporated into a single integrated circuit. The high input resistance means extremely low power consumption compared with bipolar transistors. All these factors mean that MOS technology is widely used within the electronics industry today.

Enhancement-type MOSFET's can be used in a similar way to bipolar transistors.

N-channel enhancement MOSFET's allow a current to flow between Drain and Source when the Gate is made Positive (similar to an NPN transistor). P-channel enhancement MOSFET's allow a current to flow between Drain and Source when the Gate is made Positive (similar to a PNP transistor).

N-channel enhancement MOSFET - theory

The MOSFET transistor is constructed on a piece of p-type Semiconductor, an Oxide insulating layer separates this from the Metal 'Gate' contact.

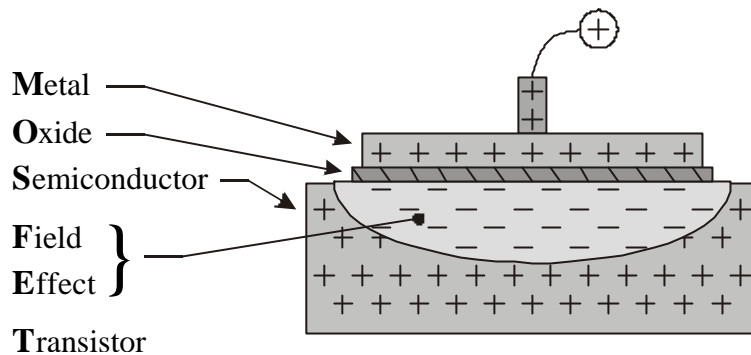

AE.H.LO1. fig 31

Making the metal contact positive will produce a Field, repelling the positive majority carriers leaving negatives behind (to produce an N-channel).

If the field produced by the Gate voltage is large enough, a channel is produced connecting the Drain and Source. When a voltage is applied between the Drain and Source, current will flow along the channel.

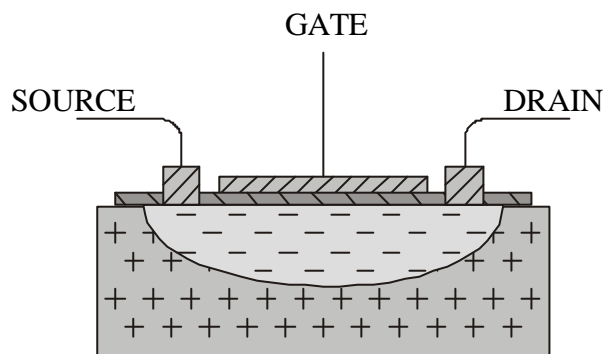

AE.H.LO1. fig 32

(In practice, the Drain and Source metal plates are connected to n-type semiconductor within the p-type substrate).

The channel acts as a resistance between the Source and Drain. The size of which depends on:

- the length (l) of the channel between D and S
- the width (w) of the channel
- the thickness (t) of the channel

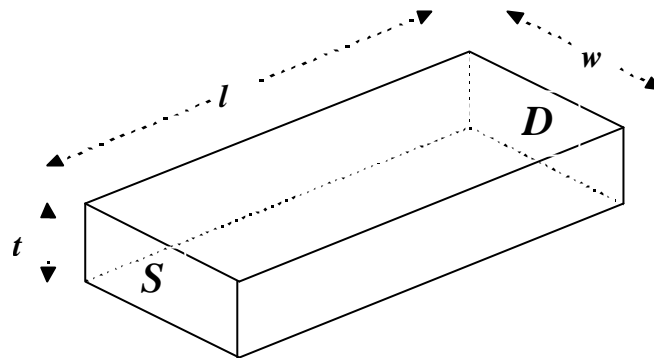

AE.H.LO1. fig 32b

l and w are determined during manufacture of the MOSFET, t is adjusted by altering the gate voltage.

For a given MOSFET, the size of the current between the Drain and Source will therefore depend on the Gate voltage (V_{GS}) and the voltage between the Drain and Source (V_{DS}).

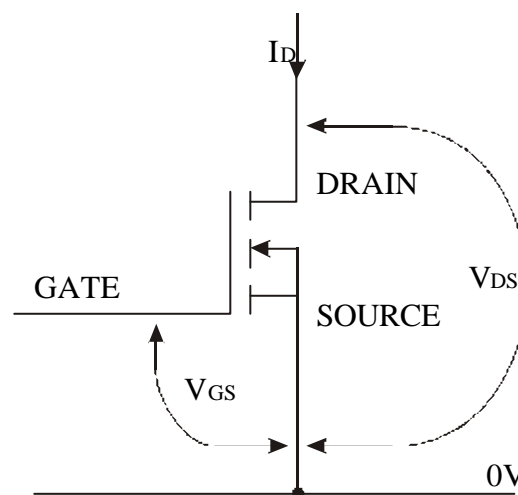

AE.H.LO1. fig 33 a

Like a bipolar transistor, if the Gate voltage is below a certain level (the threshold value, V_T), no current will flow between the Drain and Source (the MOSFET will be switched off).

If the Gate voltage is above V_T , the MOSFET will start to switch on. Increasing the Gate voltage will increase the thickness of the channel, increasing the number of charge carriers in the channel and hence increasing I_D .

For a given value of V_{GS} (above V_T), increasing V_{DS} increases the current until saturation occurs. Any further increase will cause no further increase in I_D . The MOSFET is fully ON and can therefore be used as a switch.

Saturation occurs when $V_{DS} = V_{GS} - V_T$.

If V_{DS} is $\geq V_{DS\text{saturation}}$, I_D is constant (for a given value of V_{GS}) (I_D is then known as $I_{D(\text{on})}$).

When saturation occurs $I_D = I_{D(\text{on})}$

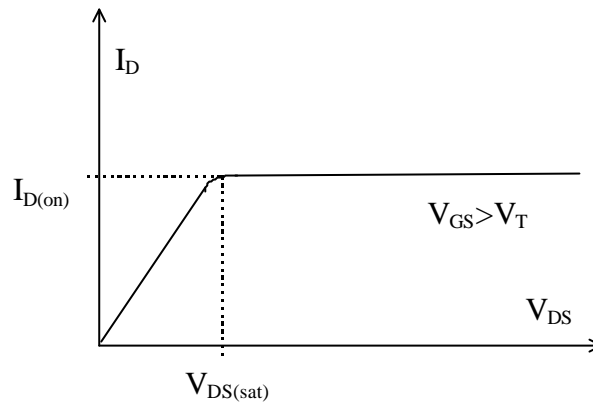

AE.H.LO1. fig 33 a i

When saturation occurs, the resistance of the channel, R_{DS} , is normally low ($R_{DS(\text{on})}$ less than 1Ω for power MOSFET's)

WORKED EXAMPLE

The threshold gate voltage for the MOSFET shown below is 2 V. Calculate the gate voltage required to ensure that a saturation current of 10 mA flows through the load resistor.

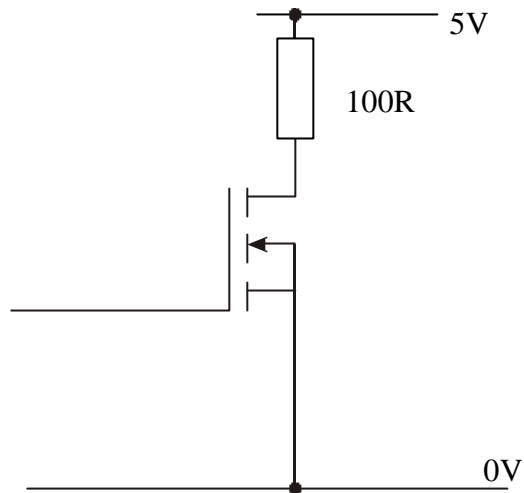

AE.H.LO1. fig 33 a ii

Step 1

The Drain - Source channel acts as a series resistor with the 100R, since the current is the same in a series circuit, the voltage over the 100R can be calculated using Ohm's law

$$V = IR = 10 \text{ mA} \times 100 = 1 \text{ Volt}$$

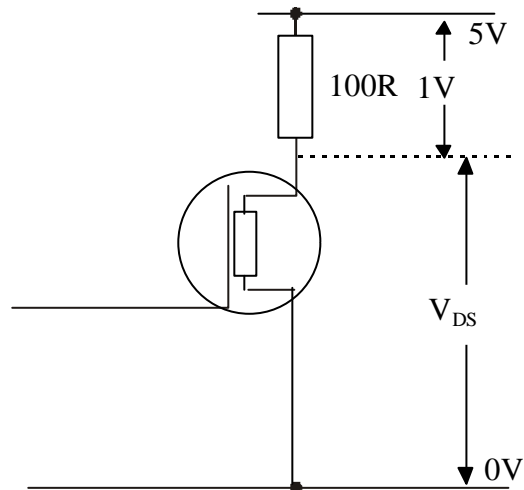

AE.H.LO1. fig 33 a iii

Step 2

Using Kirchoff's 2nd law, the voltage over the channel + the voltage over the load resistor = supply voltage hence $V_{DS} = 5 - 1 = 4 \text{ Volts}$

Step 3

For saturation to occur,

$$V_{DS} = V_{GS} - V_T$$

$$V_{GS} = V_{DS} + V_T$$

$$V_{GS} = 4 + 2 = \underline{\underline{6 \text{ Volts}}}.$$

MOSFET's can be designed to handle **very high drain currents**, this means that they can be used to drive high current output transducers drivers without the need for relay switching circuits (unlike the bipolar transistor).

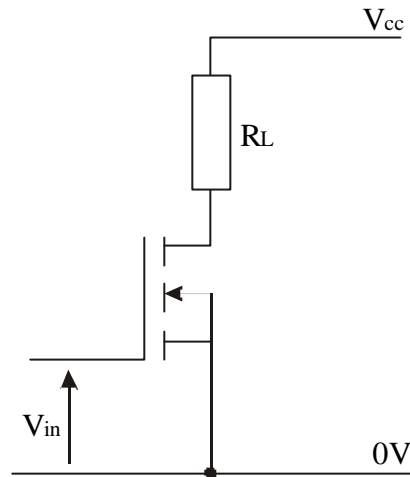

AE.H.LO1. fig 33 b

The load resistor could be any output transducer, bulb, motor, relay etc. Since MOSFET's are particularly sensitive to high voltages, care must be taken to include a reverse biased diode over transducers that may cause a back emf when switched off.

A variable resistor can be used in a voltage divider circuit and adjusted to ensure that the input voltage to the gate = V_T

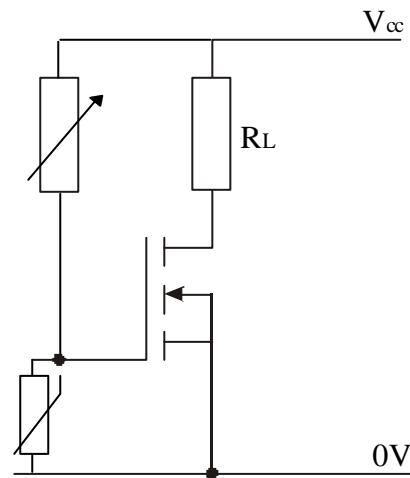

AE.H.LO1. fig 33 c

Changes in V_{GS} (ΔV_{GS}) above the threshold value causes changes in I_D (ΔI_D) Whereas the performance of a bipolar transistor is measured by its' amplification (h_{fe}), the performance of a FET is measured by its *transconductance* (g_m) and is calculated by

$$g_m = \frac{\Delta I_D}{\Delta V_{GS}}$$

g_m is measured in Amps per Volt (AV^{-1})

[These units are sometimes referred to as siemens or mhos]

MOSFET's connected as shown in figure 33b are said to be in common-source mode (c.f. common-emitter mode for bipolar transistors).

PRACTICAL ASSIGNMENT 1.2

MOSFET characteristics - relationship between Drain current (I_D) and Gate voltage (V_{GS})

Construct the circuit shown below using multimeters to measure the drain current and the gate voltage.

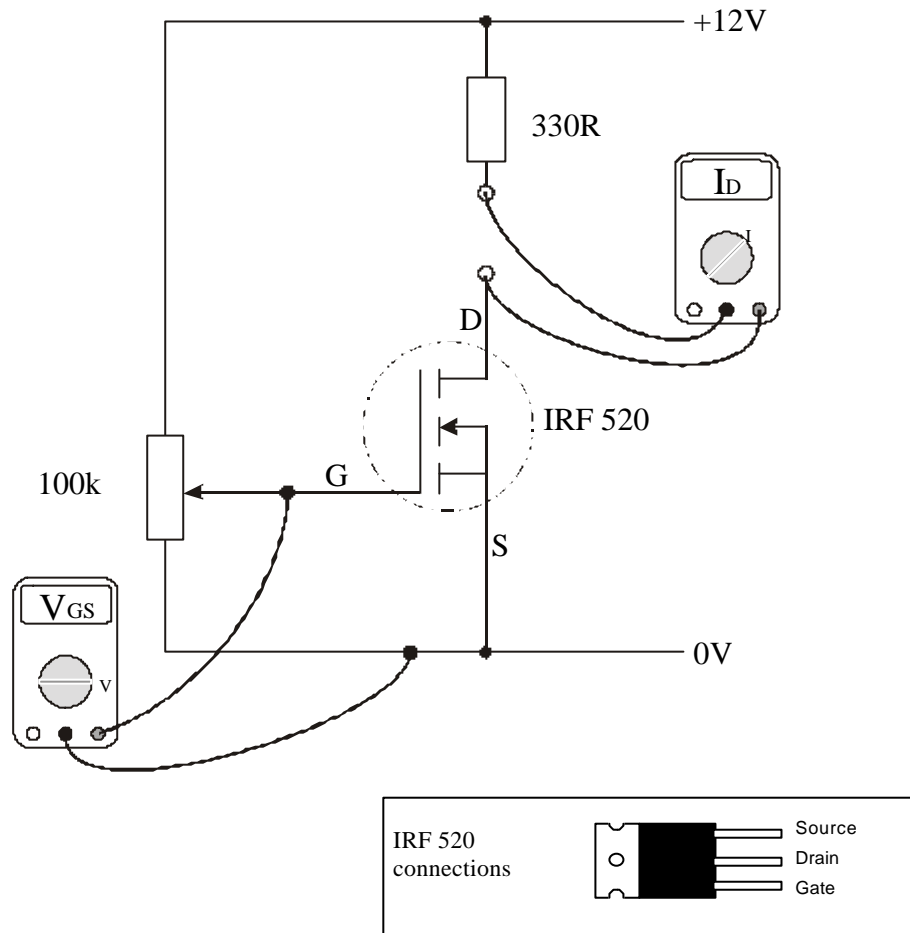

AE.H.LO1. fig 34

Adjusting the potentiometer will allow you to change V_{GS} .

Construct a table for recording your results (as shown below).

V_{GS} (V)	I_D (mA)

Measure I_D for various values of V_{GS} .
Find the threshold voltage for this MOSFET

Plot a graph of I_D against V_{GS} and calculate g_m for this MOSFET.

Construct the circuit shown below.

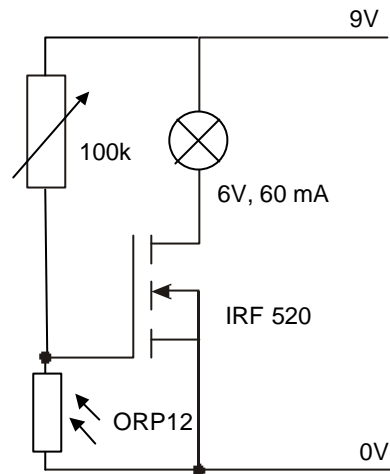

Adjust the 100k variable resistor until the light just goes off.
(This means that $V_{GS} < V_T$)

Covering up the LDR will increase V_{GS} and the light should come on.

The Push-Pull Amplifier

NPN bipolar transistors and n-type enhancement MOSFETs operate when the base or gate is made positive with respect to the zero volt line.

PNP and p-type MOSFETs operate off negative signals.

A push-pull amplifier consists of one of each type of bipolar transistor (or MOSFET) connected in series with a + and - supply rail.

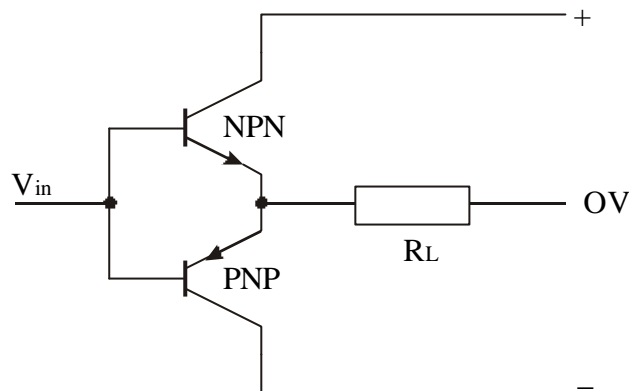

AE.H.LO1. fig 35

If V_{in} is **Positive** with respect to 0V, the **NPN** transistor will switch on, current will flow from the + supply line through the collector-emitter junction, through the load resistor down to the 0V line

If V_{in} is **Negative** with respect to 0V, the **PNP** transistor will switch on, current will flow from the 0V line through load resistor, through the emitter-collector junction, to the + supply line.

The direction of current flow through the load resistor will therefore depend on whether the input voltage is positive or negative. If the load resistor is replaced by a motor, the direction of rotation of the motor can be altered dependent on the input voltage.

Circuit Simulation Software.

Using Crocodile Clips or another similar software package construct the following circuit.

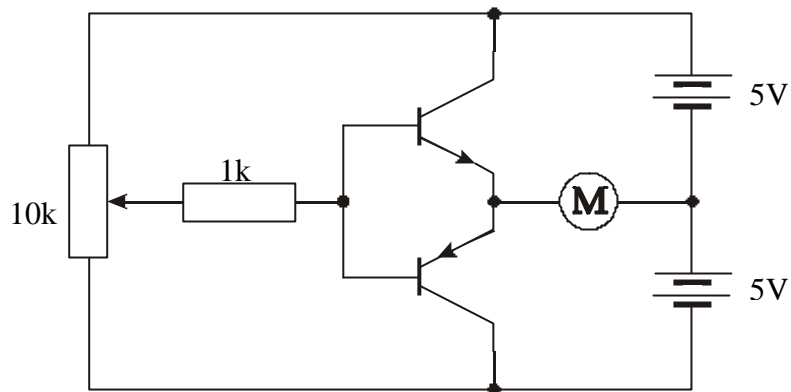

AE.H.LO1. fig 36

Investigate what happens when the potentiometer slider is altered.

Construct the circuit shown below onto breadboard.

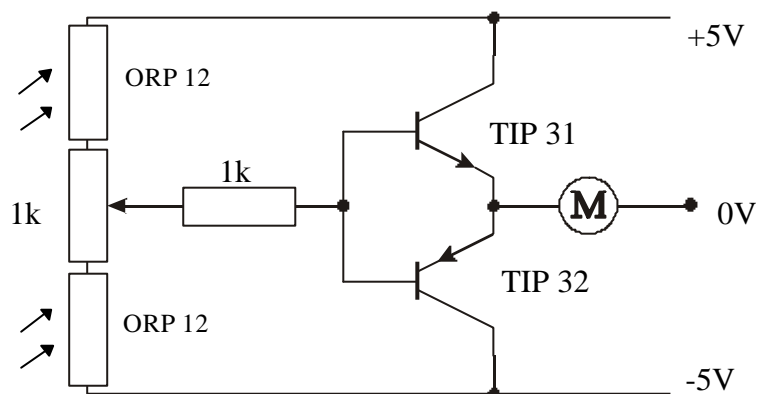

Adjust the variable resistor until the motor is stationary.

Investigate what happens when you shade each LDR in turn.

SEB & SQA PAST PAPER EXAM QUESTIONS

1995, Paper 1, question 2

The following electronic system is set up for a test with various ammeters and voltmeters connected as shown in Figure Q1. In the condition shown, the transistor is fully saturated with a base current of 500 mA .

Write down the readings which you would expect to see on each of the four voltmeters ($V_1 - V_4$) and the two ammeters ($A_1 - A_2$).

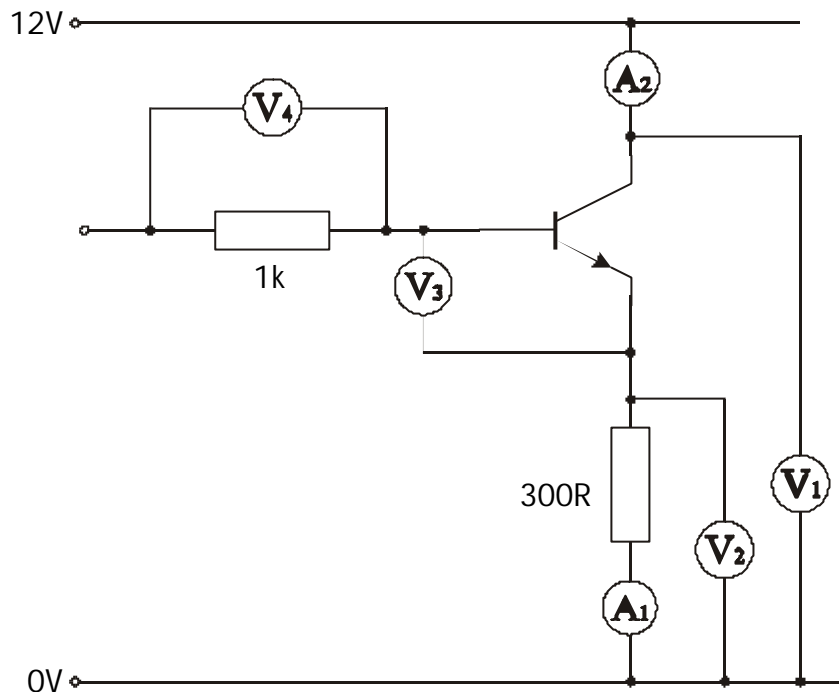

Figure Q1

1994, Paper 1, question 1

A designer is asked to construct an electronic circuit which will energise a relay at a set light level. Having investigated the characteristics of the light transducer, she finds that the resistance of the transducer at “switch on” level is $2.1\text{ M}\Omega$. The proposed design is shown in Figure Q2. The transistor saturates when $V_{be} = 0.6\text{V}$.

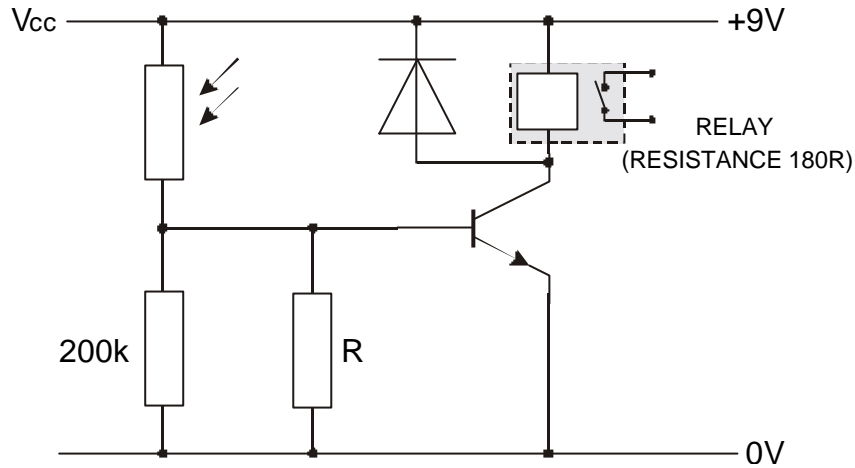

Figure Q2

Determine, assuming the transistor is in a fully saturated condition:

- the value of the unknown resistor R required to make the transistor operate correctly;
- the power dissipated in the relay coil.

1993, Paper 1, question 2

The control circuit for a cooling fan is based on a thermistor. The graph in Figure Q3(i) shows the operating characteristics of the thermistor and Figure Q3(ii) shows the proposed circuit diagram.

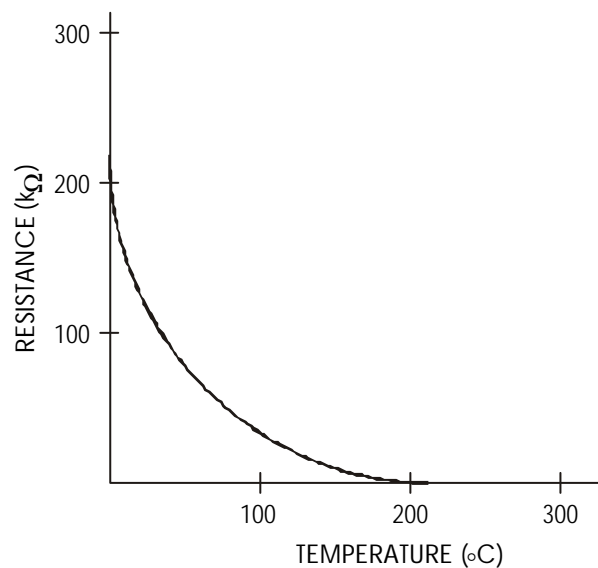

Figure Q3 (i)

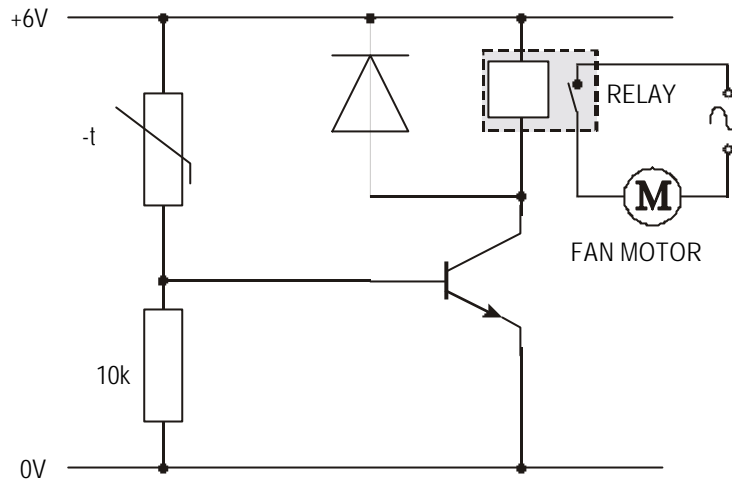

Figure Q3 (ii)

- (a) (i) The motor should switch on when $V_{be} = 0.6V$. For this condition, calculate the value of R_t .
- (ii) From the graph, determine the temperature at which the fan **should** switch on.
- (b) When the circuit is built and tested, it is found that the relay does not operate at the switch - on temperature.
- (i) Suggest **one** reason why the transistor fails to operate the relay.
- (ii) **Redraw** the circuit diagram to show how a Darlington pair could be used to overcome this problem.

1998, Paper 2, question 4 (c)

(amended)

An instant electric shower is designed to deliver water at a fixed temperature from a cold water supply.

An additional safety feature is to be added which will switch off the power to the shower if the water temperature produced by the heating element becomes dangerously high (greater than 50 °C).

Figure Q4 shows the proposed safety system circuit. The relay requires an operating current of 250 mA. The resistance of the thermistor at 50°C is 1 kΩ.

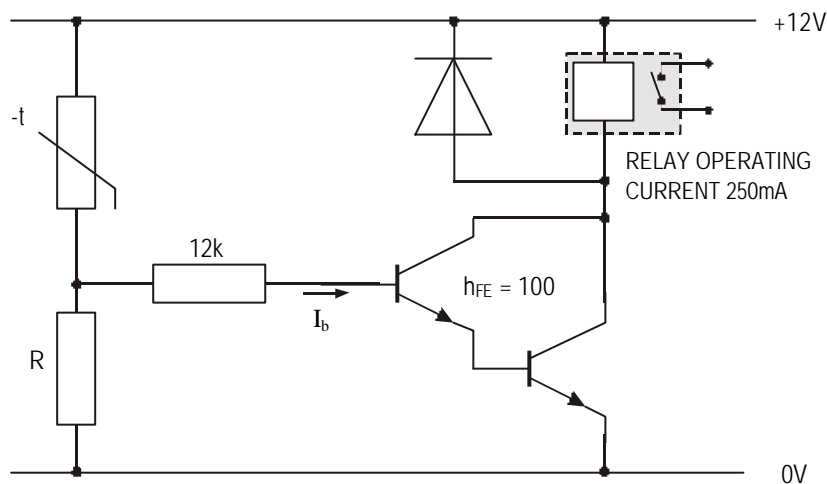

Figure Q4

- (i) Name the transistor configuration used in this circuit.
- (ii) State one advantage of using this configuration.
- (iii) For the relay to operate:
 - calculate the base current, I_b ;
 - calculate the potential difference across the 12k Ω resistor;
 - determine the voltage across the fixed resistor R;
 - calculate the value of R

TECHNOLOGICAL STUDIES

HIGHER

APPLIED ELECTRONICS

SECTION 2

OUTCOME 2

APPLIED ELECTRONICS

Outcome 2 - Design and construct electronic systems, based on operational amplifiers, to meet given specifications

When you have completed this unit you should be able to:

- state the characteristics of an ideal Operational Amplifier;
- identify the various op. amp. configurations;
- carry out calculations involving op. amps.;
- select a suitable op. amp. circuit for a given purpose;
- design op. amp. circuits for a given purpose.

Before you start this unit you should have a basic understanding of:

Input and Output transducers.

Potential divider circuits.

Ohm's Law - relationship between V and I in a d.c. circuit.

The operational characteristics of various electronic components.

Use of breadboards.

Use of circuit test equipment: multimeter and oscilloscope.

Operational amplifiers

Nowadays, circuits with specific designs can be constructed on a single piece of silicon (chip). These are known as **integrated circuits (ic's)**.

One such ic is known as an operational amplifier (op. amp.).

This ic was designed to perform mathematical operations and was originally used in analogue computers. The op. amp. can be used to add, subtract, multiply, divide, integrate and differentiate electrical voltages. It can amplify both d.c. and a.c. signals. (and at the time of writing, costs about 20 pence!)

An "ideal" amplifier should have the following qualities:

- an infinite input resistance (typically 1M or more) - so that very little current is drawn from the source;
- zero output resistance (typically 100 Ω or less) - so that variations in load have very little effect on the amplifier output;
- an extremely high gain (typically 100,000);
- no output when the input is zero (in practice this is seldom achieved, however manufacturers provide an "offset - null" to compensate for this).

Although a typical op. amp. can contain more than 20 transistors and other components, we can treat it as a "black box" since we are only concerned with the input and output signals.

The symbol for an op. amp. is shown in figure 1

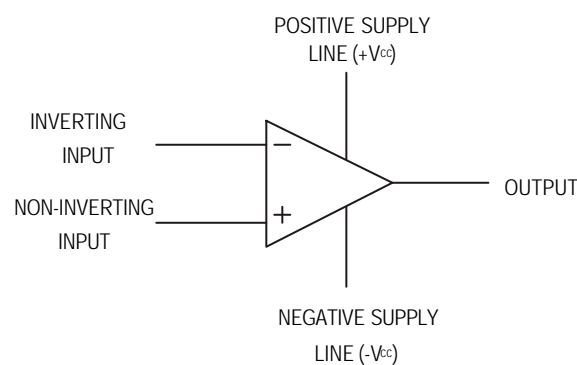

AE.H.LO2. fig 1

It can be seen from the diagram that the op. amp. has two inputs.

The op. amp. is designed as a differential amplifier i.e. it amplifies the difference between the two input voltages.

The two inputs are indicated by a "-" and "+".

A positive signal to the "-" input is amplified and appears as a negative signal at the output. Because of this, the "-" input is known as the inverting input (a negative signal would appear as a positive at the output).

A positive signal to the "+" input is amplified and appears as a positive signal at the output. The "+" input is known as the non-inverting input.

If both inputs are exactly the same i.e. there is no difference, then the output should be zero.

Since the input and output signals can be either positive or negative, the op. amp. is usually powered from a dual rail supply and voltages measured relative to a zero volt (or ground) line.

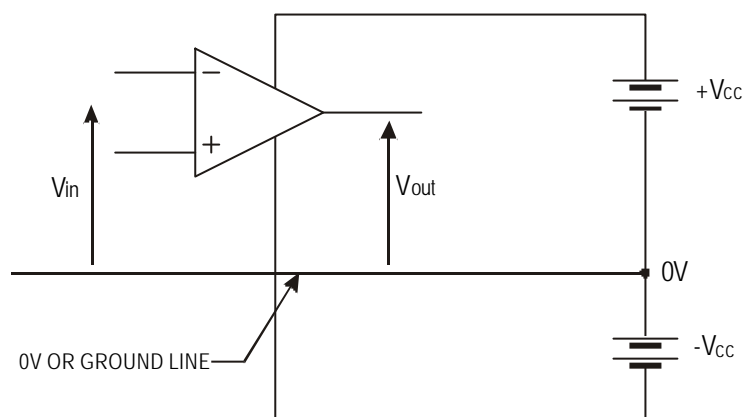

AE.H.LO2. fig 2

(It is normal practice to omit the power lines when drawing diagrams - these are taken for granted)

Op. amp. ic's come in two forms, the most popular of which is the dil (dual - in - line) package. The pin diagram is shown in fig 3

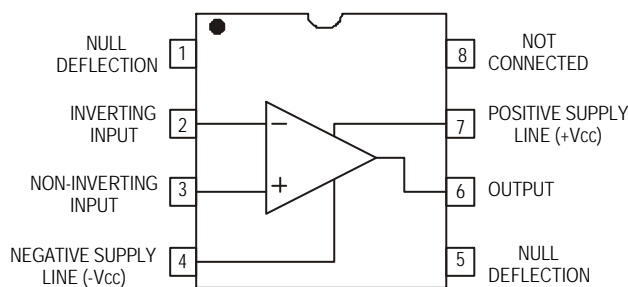

AE.H.LO2. fig 3

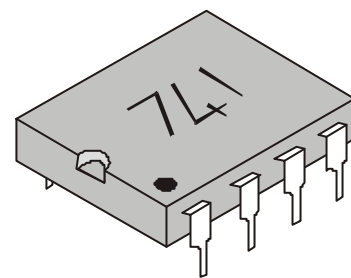

AE.H.LO2. fig 4

The top of any ic is usually indicated by a notch. Occasionally pin number 1 is indicated by a dot. Pins are always numbered from pin 1 in an anti - clockwise direction.

Connections to the offset null are usually made by means of a potentiometer. This will depend on the type of op. amp. used and reference should be made to appropriate data sheets if this is required.

GAIN

The op. amp. was designed as a voltage amplifier.

The voltage gain of any amplifier is defined as

$$\text{Voltage gain} = \frac{\text{Voltage output}}{\text{Voltage input}}$$

$$A_v = \frac{V_o}{V_i}$$

For a differential amplifier, the voltage input is the difference between the two inputs.

$$V_i = (V_{(\text{at non - inverting input})} - V_{(\text{at inverting input})})$$

ASSIGNMENT 2.1

- If $V_{(\text{at non-inverting input})} = 3.10 \text{ V}$ and $V_{(\text{at inverting input})} = 3.11 \text{ V}$. Calculate the input voltage and hence the output voltage if the gain is known to be 100.
- The gain of an op. amp. is known to be 100,000. If the output voltage is 10 V, calculate the input voltage.
- The gain of an op. amp. is known to be 200,000. If $V_{(\text{at non-inverting input})} = 2.5 \text{ V}$ and $V_{(\text{at inverting input})} = 2.2 \text{ V}$, calculate the output voltage.

The answer to (c) is obviously unrealistic since the output voltage from an op. amp. cannot be greater than the supply voltage.

As the output of the op. amp. increases, saturation starts to occur and a "clipping" effect will be noticed. This normally occurs when the output reaches 85% of V_{CC} . Any further increase in the input will cause no further increase in the output since the op. amp. has reached saturation.

The inherent voltage gain of an op. amp. (i.e. when no external components are connected) is designed to be very large (200,000 in some cases). This is sometimes called the open loop gain, A_o .

If saturation does not occur then the two input voltages to the chip must be (almost) equal. Any small difference would be amplified by A_o and produce saturation.

In order to reduce the gain, a small part of the output signal is fed back to the inverting input through a feedback resistor, R_f .

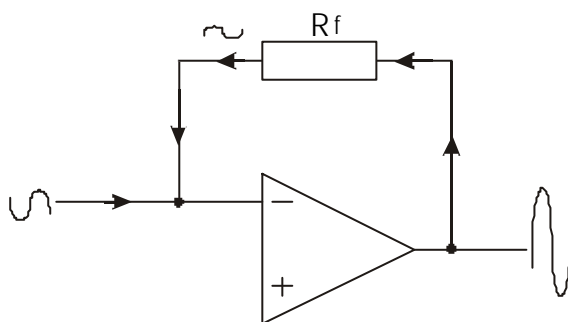

AE.H.LO2. fig 5

Since this signal is going to the inverting input, it is a form of negative feedback and has the effect of reducing the overall gain of the circuit. The *closed* loop voltage gain, A_v , of the circuit will depend on the circuit configuration.

N.B. Irrespective of the configuration, the feedback resistor is always connected to the inverting input.

The inverting amplifier configuration

The signal is connected to the inverting input through an input resistor (R_1). The non-inverting input is connected to ground either directly or through a biasing resistor R_b . (if used, R_b should have the equivalent resistance as R_1 and R_f connected in parallel).

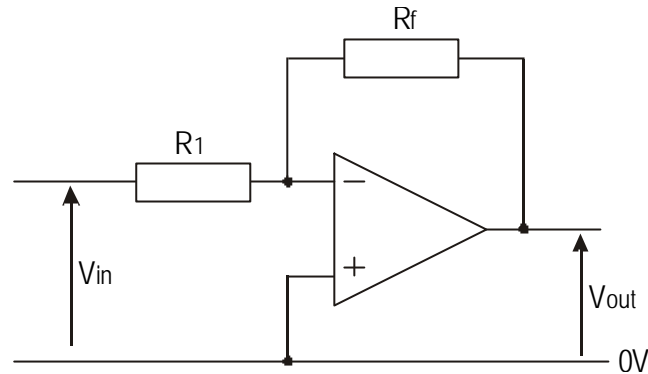

AE.H.LO2. fig 6

Characteristics of the inverting amplifier

$$\text{closed loop voltage gain, } A_v = -\frac{R_f}{R_1}$$

(negative sign indicates inversion)

input resistance of the circuit = R_1

Note: the gain is only a function of R_1 and R_f and not dependent on the open loop gain.

Worked example

An op. amp. is used in a circuit as shown in fig 6 with $R_1 = 15 \text{ k}$ and $R_f = 470 \text{ k}$. Calculate the gain of the circuit and determine the output voltage when an input signal of 0.2 v is applied.

Step 1

Calculate the gain

$$A_v = -\frac{R_f}{R_1} = -\frac{470\text{k}}{15\text{k}} = \underline{\underline{-31.33}}$$

Step 2

Calculate the output voltage

$$V_{\text{out}} = A_v \times V_{\text{in}} = -31.33 \times 0.2 = \underline{\underline{-6.266 \text{ V}}}$$

ASSIGNMENT 2.2

A thermocouple known to produce an output of 40 *m*volts per °C is connected to an op. amp. Circuit as shown in fig 7

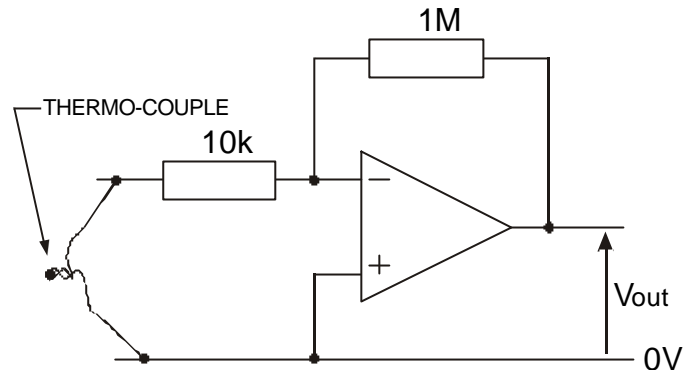

AE.H.LO2. fig 7

- Calculate the gain of the circuit.
- Determine the output voltage if the thermocouple is heated to a temperature of 1000 °C.

For an inverting amplifier, the sign of the output voltage is the opposite of the input voltage. In order to obtain the same sign, the output signal could then be fed through another inverter (with $R_f = R_i$, so that the gain = -1).

The non - inverting amplifier configuration

The signal is connected directly to the non - inverting input.

R_f and R_1 form a voltage divider circuit feeding back some of the output signal to the inverting input.

Figures 8 (a) and (b) show two different ways of drawing the same circuit.

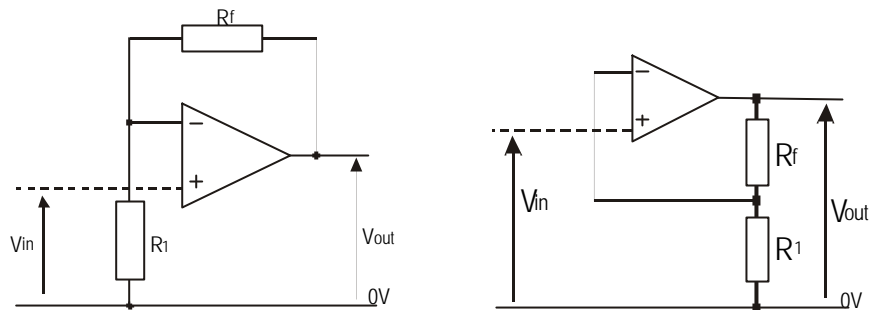

AE.H.LO2. fig 8 a & b

Characteristics of the non - inverting amplifier

$$\text{closed loop voltage gain, } A_v = 1 + \frac{R_f}{R_1}$$

(no inversion, gain is positive)

input resistance of the circuit = input resistance of the op. amp.
(very high)

Note: because of the high input resistance, this circuit is useful when input transducers do not provide large currents.

ASSIGNMENT 2.3

To build a simple light meter, a light dependent resistor (LDR) is connected into a circuit as shown in figure 9

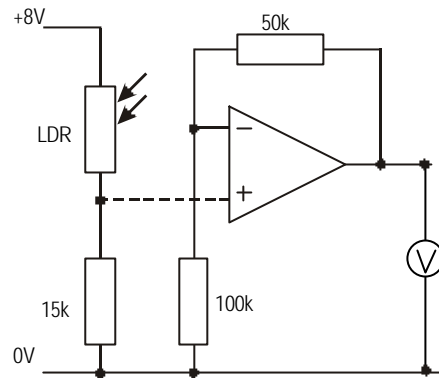

AE.H.LO2. fig 9

In bright sunlight, the LDR has a resistance of 1 k. In shade, its resistance increases to 15 k.

- Determine the voltages that would appear on the voltmeter in both light conditions.
- How could the circuit be altered to indicate changes in temperature?

The voltage follower

This is a special case of the non-inverting amplifier in which 100% negative feedback is obtained by connecting the output directly to the inverting input.

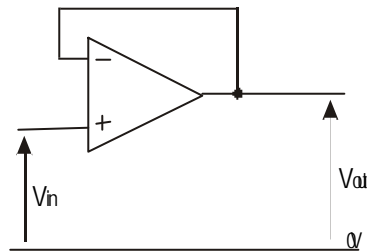

AE.H.LO2. fig 10

Since $R_f = 0$, the gain of this circuit is 1 i.e. The output voltage = input voltage.

The practical application of this circuit is that it has a very high input resistance and a very low output resistance. It is therefore used in matching a source that can only produce a low current to a load which has a low resistance.

Circuit Simulation Software.

It is possible to use circuit simulation software such as ‘Crocodile Clips’ to investigate electric and electronic circuits. Circuit simulation is widely used in industry as a means of investigating complex and costly circuits as well as basic circuits.

Circuit simulators make the modelling and testing of complex circuits very simple. The simulators make use of libraries of standard components along with common test equipment such as voltmeters, ammeters and oscilloscopes.

Using Crocodile Clips or another similar software package construct and test the following circuits.

1. Construct the circuit shown in figure 10 b.

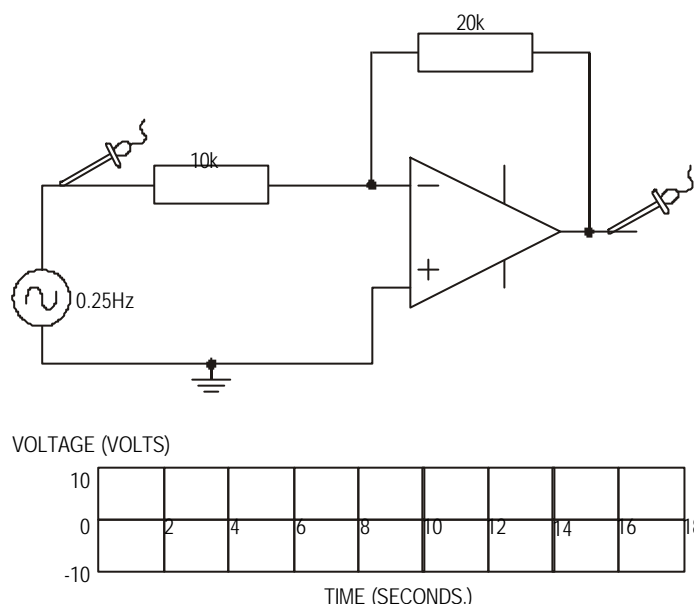

AE.H.LO2. fig 10 b

Set the input voltage to 2 Volts, 0.25 Hz.

Set the oscilloscope to a maximum voltage of 10 V and a minimum voltage of -10 V
Start the trace on the oscilloscope and compare the input and output voltages.

Now increase the size of the feedback resistor to 50 k and repeat the exercise. This time you should observe “clipping” of the output signal.

2. Construct the “electronic thermometer” circuit shown in figure 10 c.

This uses an inverting amplifier and a voltage follower.

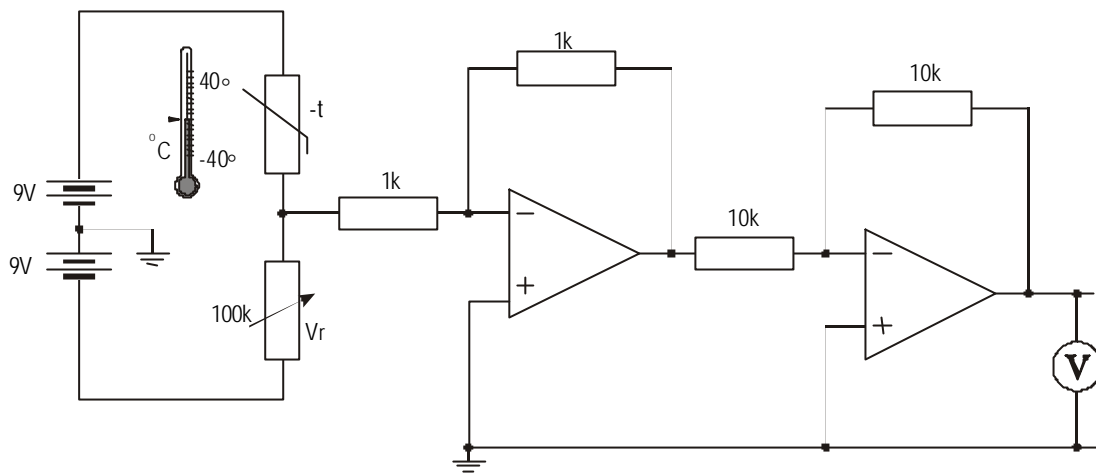

AE.H.LO2. fig 10 c

Set the “temperature” to 0°C, adjust the variable resistor (V_r) until the voltmeter reads 0.00.

Increase the “temperature” to 40 °C, adjust the feedback resistor in the inverting amplifier until the voltmeter reads 0.40

The electronic thermometer is now calibrated to read 0.00 at 0°C and 0.40 at 40°C. Investigate voltage readings at various other “temperatures” and suggest why this would not make a good thermometer.

The summing amplifier

Here, two (or more) signals are connected to the inverting input via their own resistors. The op. amp. effectively amplifies each input in isolation of the others and then sums the outputs.

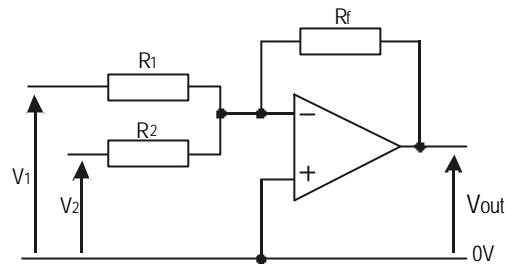

AE.H.LO2. fig 11 a

Characteristics of the summing amplifier

Each input signal is amplified by the appropriate amount (see inverting mode)

$$V_{out} = \left(-\frac{R_f}{R_1} \times V_1\right) + \left(-\frac{R_f}{R_2} \times V_2\right) + (\text{any other inputs})$$

$$V_{out} = -R_f \left(\frac{V_1}{R_1} + \frac{V_2}{R_2} + \dots\right)$$

Notes:

- any number of inputs can be added in this way.
- R_f affects the gain of every input.
- if all the resistors are the same size, then the gain for each input will be -1 and $V_{out} = -(V_1 + V_2 + V_3 + \dots)$

Circuit simulation

1. Digital-to-analogue converter

Digital devices produce ON/OFF signals. Processing takes place using the binary number system (as oppose to the decimal system).

Construct the circuit shown in figure 11 b

This circuit contains a summing amplifier and a voltage follower.

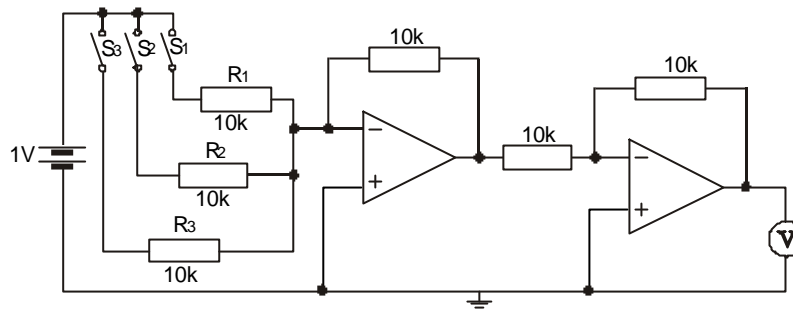

AE.H.LO2. fig 11 b

Since all inputs are amplified by the same amount (same value of input resistors) the output voltage = \sum input voltages e.g. S1, ON (connected to 1V) and S2, ON (connected to 1V), the output voltage should = $(1 + 1) = 2V$

Now change the circuit so that $R_2 = 5k$ and $R_3 = 2.5k$

Copy and complete the following table to show the state of the input switches and the output voltage.

(N.B. "1" means the switch is ON, 0, OFF)

S3	S2	S1	output voltage (V)
0	0	0	
0	0	1	
0	1	0	
0	1	1	
1	0	0	
1	0	1	
1	1	0	
1	1	1	

2. a.c. mixer pre-amplifier

Mixers allow different signals to be amplified by different amounts before being fed to the main amplifier. Signals might come from microphones, guitar pick-ups, vocals, pre-recorded sound tracks etc.

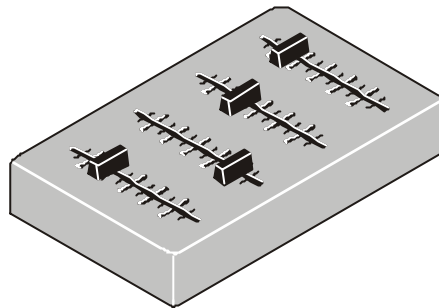

Construct the circuit shown in figure 11 c
Adjust the frequencies of the signals as shown and adjust the oscilloscope to give a maximum voltage of 10 V and a minimum of -10 V.

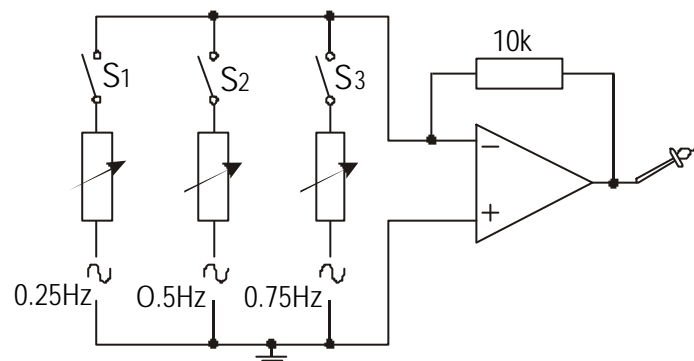

AE.H.LO2. fig 11 c

Putting each switch on individually will allow you to “see” each of the input signals in turn.

Putting more than one switch on at a time will show you the sum of the input signals. Adjusting the size of the input variable resistors alters the amplification of that particular input signal.

(Complex output signals can be constructed by adding sine waves of the correct amplitude and frequency - useful in electronic keyboards or synthesisers when a particular musical instrument is required.)

ASSIGNMENT 2.4

Determine the output voltage for the circuit shown in figure 12

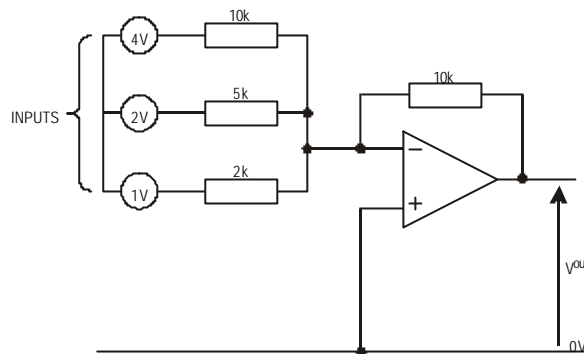

AE.H.LO2. fig 12

ASSIGNMENT 2.5

A personal stereo has both tape and radio inputs which produce output signals of 50 mV and 10 mV respectively. The amplifying system consists of a main amplifier and uses an op. amp. as a pre - amplifier. Design a possible pre - amplifier circuit so that an output of 1 volt is produced when either the tape or radio inputs are used.

The difference amplifier configuration

Here both inputs are used. The op. amp. amplifies the difference between the two input signals.

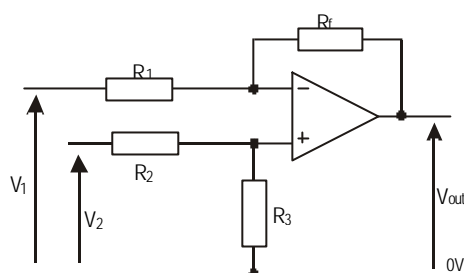

AE.H.LO2. fig 13

To ensure that each input is amplified by the same amount, the circuit is designed so that the ratio:

$$\frac{R_f}{R_1} = \frac{R_3}{R_2}$$

To ensure that the input resistance of the circuit for each input is the same,

$$R_1 = R_2 + R_3$$

Characteristics of the difference amplifier

$$A_v = \frac{R_f}{R_1}$$

$$V_{out} = \frac{R_f}{R_1} \times (V_2 - V_1)$$

$$\text{input resistance} = R_1$$

Note:

if $R_1 = R_f$ then $A_v = 1$ and $V_{out} = (V_2 - V_1)$, the circuit works as a "subtractor".
the output will be zero if both inputs are the same.

This circuit is used when comparing the difference between two input signals.

ASSIGNMENT 2.6

Two strain gauges are connected to a difference amplifier as shown in figure 14

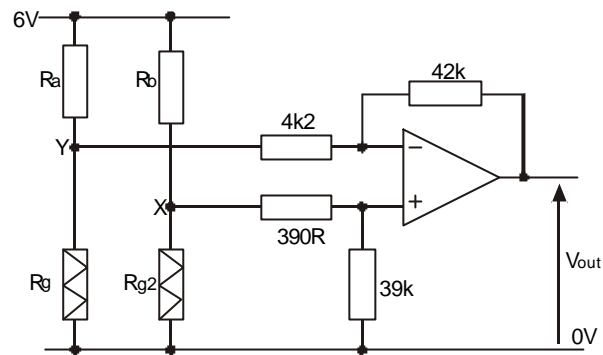

AE.H.LO2. fig 14

$R_A = R_B = 1 \text{ k}$, when not under strain, $R_{g1} = R_{g2} = 200 \text{ } \Omega$

- Calculate the voltage at X and Y when both gauges are not under strain and hence determine the output voltage of the amplifier.
- As the strain of R_{g2} increases, its resistance increases from 200 to 210 Ω , determine the new output voltage.
- What would you expect to happen to the output voltage if both gauges were put under the same amount of strain?

The comparator configuration

This is a special case of the difference amplifier in which there is no feedback (see fig 15). The gain of the circuit is therefore A_o and any small difference in the two input signals is amplified to such an extent that the op. amp. saturates (either positively or negatively).

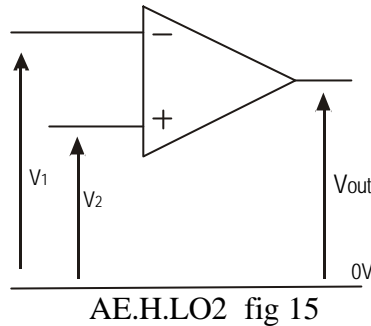

$$A_V = A_o$$

$$V_{out} = A_o \times (V_2 - V_1)$$

hence if $V_2 > V_1$, V_{out} is **positive**, if $V_2 < V_1$, V_{out} is **negative**

This is commonly used in control circuits in which loads are merely switched on and off.

e.g. The circuit shown in figure 16 would give an indication when the temperature falls below a preset value (0°C for example).

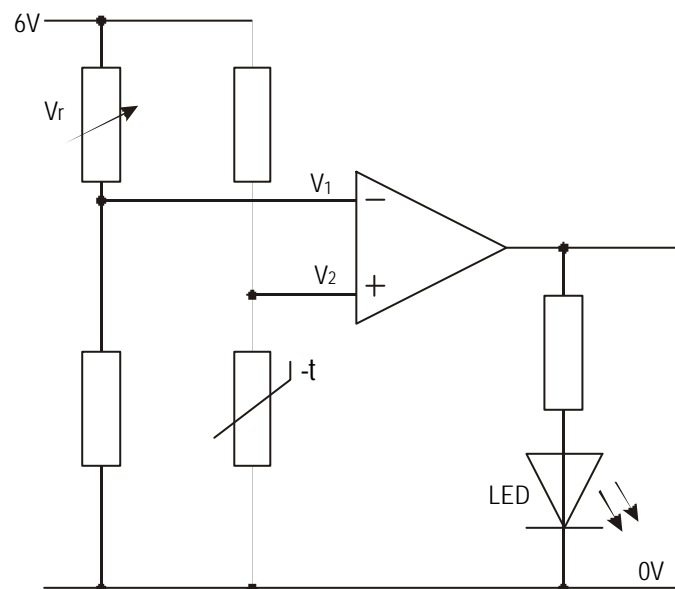

AE.H.LO2. fig 16

V_r is adjusted until V_1 is just greater than V_2 , the output will therefore be negative and the led will be off.

As the temperature falls, the resistance of the ntc thermistor rises and therefore V_2 starts to rise. Eventually, $V_2 > V_1$, the output goes positive and the led lights.

N.B. Since nothing happens when the output of the op. amp. goes negative, this circuit could be operated from a single power rail (as oppose to a dual power rail) as shown in figure 17

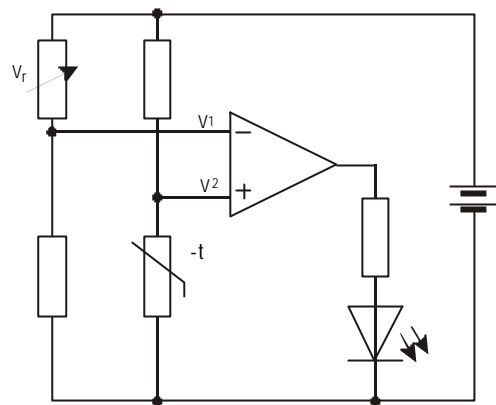

AE.H.LO2. fig 17

Here, when $V_1 > V_2$, the output will try and go "as negative as possible" i.e. down to 0 volts and the led will be off.

Driving external loads

The maximum output current that can be drawn from an op. amp. is usually low (typically 5 mA). If larger currents are required, the output could be connected to a transducer driver either a bipolar transistor or MOSFET (and relay circuit if required).

ASSIGNMENT 2.7

Describe the operation of the circuit shown in figure 18 and state the purpose of the variable resistor V_r and the fixed resistor R_b (for clarity, the d.c. power supply has not been shown)

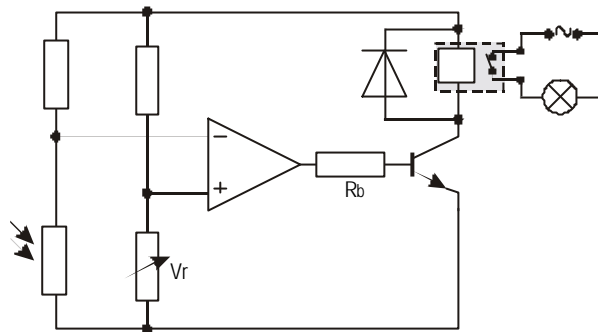

AE.H.LO2. fig 18

Control systems

In a control or servomechanism system a feedback loop is included in the circuit. This monitors the output and necessary changes are made to ensure that the level of the output remains at a constant level.

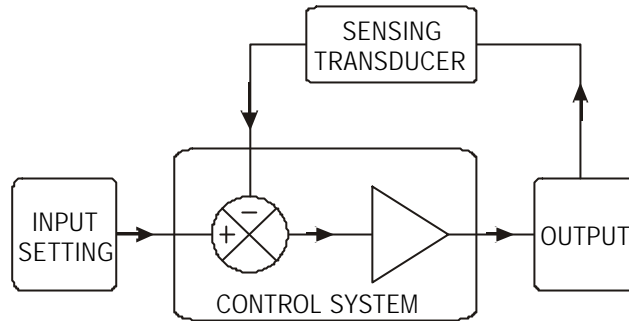

AE.H.LO2. fig 19

The difference between the input setting and the actual output as monitored by the transducer will produce an error. This error is then used to alter the output of the control system.

e.g. The temperature control of a freezer is set at a given value. A transducer then monitors the temperature and switches the freezer pump on and off accordingly.

In a non-feedback system (sometimes known as an open-loop system), the inputs are adjusted to give the expected output and then left.

Changes in conditions (load, environment, wear & tear etc.) may result in the output varying from the level set by the inputs. These changes are not taken into account by the open-loop system.

For example, the speed of an electric motor may be set by an input variable resistor, load on the motor however will cause it to slow down and the output speed will be less than expected for the given input conditions.

In it's simplest form, a feedback (or closed-loop) system provides an on/off output in which a mechanical or electronic relay, switches the power circuit on or off. This on/off operation will cause the output to "hunt" above and below the required level. In some cases, an on/off system may be all that is required.

A better form of feedback loop is where the output is proportional to the difference between the preset level and the feedback signal. This results in smoother control, for example, in an electrical heater where the output power of the heater can be varied according to the difference between the preset temperature and the actual temperature. If the temperature difference is large, the heater might be working at full power, as the temperature of the room increases, the temperature difference between the preset value and the actual temperature will decrease and therefore the output power of the heater will decrease.

PRACTICAL ASSIGNMENT 2.1

Measurement of motor speeds

The speed of a rotating shaft or spindle can be measured by attaching a disc with a section cut out.

A schematic diagram of the circuit is shown below.

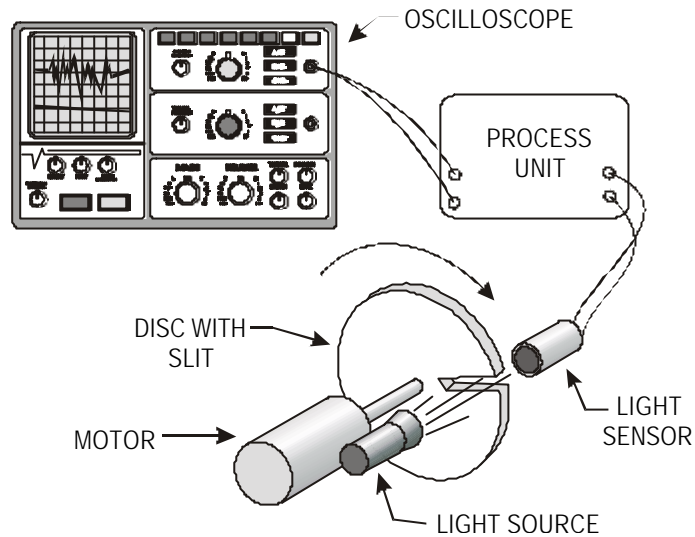

AE.H.LO2. fig 20

A light source and sensor are placed on either side of the disc. As the shaft rotates, the light beam is interrupted. The time taken for one complete revolution can be measured using a calibrated CRO.

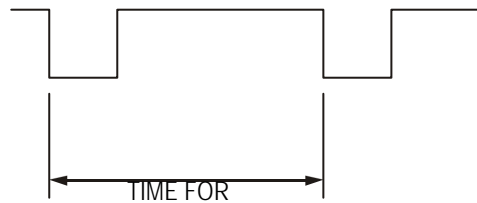

AE.H.LO2. fig 21

Two possible circuits, one using a photo diode and another using an LDR are shown below.

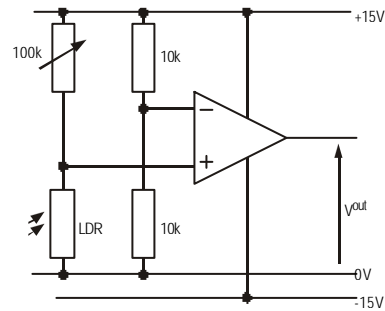
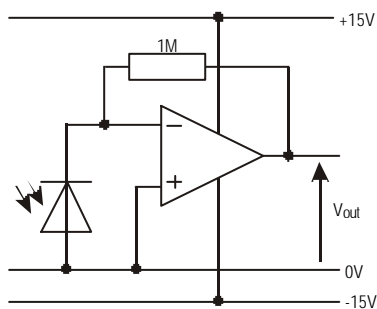

AE.H.LO2. fig 22 fig 23

Investigate each circuit and suggest with reasons which one should be used.
(Start the motor at a low speed and make sure that pulses are obtained on the CRO then slowly increase the speed until the motor is at its working speed.)

The speed of a lathe can be measured if a white line is painted on the spindle. What changes if any would have to be made to the sensor?

PRACTICAL ASSIGNMENT 2.2

Air conditioning system

Most domestic central heating systems only operate when the temperature is below a preset level. In an air conditioning system, the temperature of the room air is not only heated when the temperature is too low but the air can also be cooled when the temperature is too high. This could easily be done by incorporating a fan. In the circuit diagram shown below, the motor represents the fan and the bulb represents the heater.

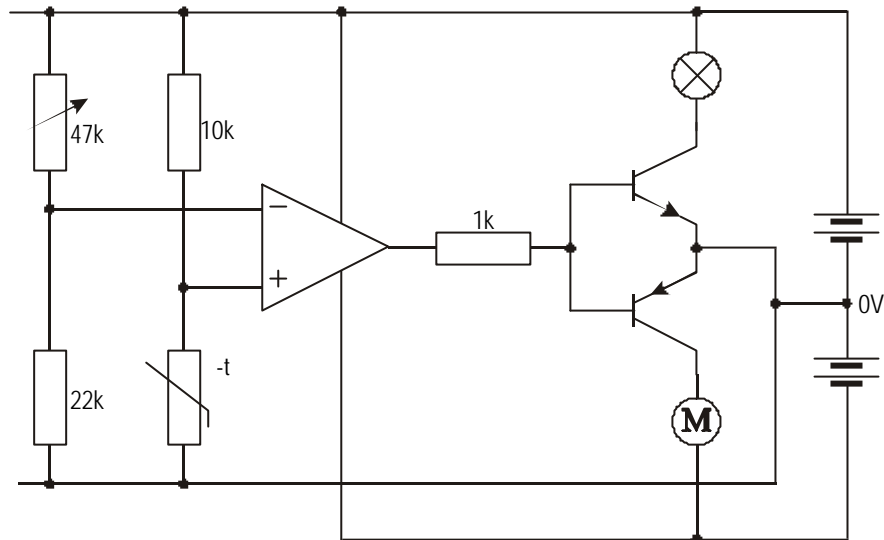

AE.H.LO2. fig 24

This particular circuit has at least one drawback. By investigating the circuit, suggest what this is and how it could be overcome.

(Note: wires are not joined where the lines of the circuit diagram cross over unless the crossover point is marked by a dot.)

PRACTICAL ASSIGNMENT 2.3

Measurement of load

Strain gauges can be used to investigate the load on particular members of a construction. The resistance of a strain gauge depends on whether it is under tension or compression. It will also however depend on temperature.

The diagram below shows a single strain gauge bonded to the upper face of a metal strip.

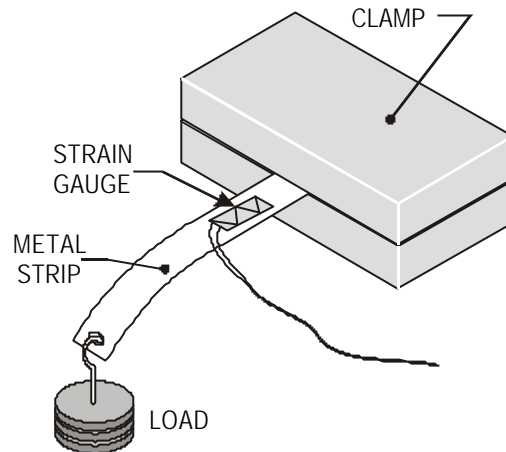

AE.H.LO2. fig 25

As loads are placed on the strip, it bends, stretches the strain gauge which in turn changes resistance. This change in resistance can be amplified using a differential op. amp. Circuit as shown below.

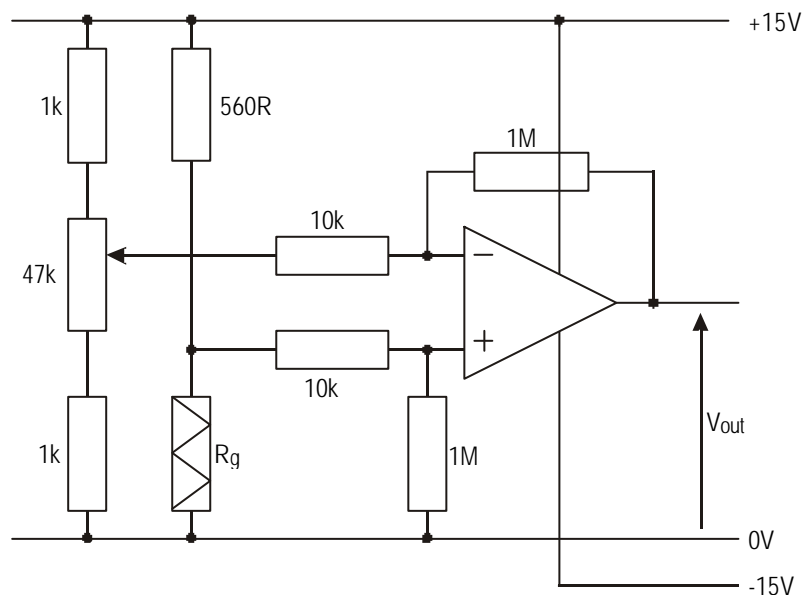

AE. H.LO2. fig 26

Construct the circuit as shown, adjust the variable resistor so the voltmeter reads zero when no load is applied to the metal strip.

Determine if the voltage output is proportional to the load applied to the strip.

Since the resistance of the gauge also depends on temperature, any temperature change will be "recorded" as a change in load. In order to overcome this, it is normal to use two strain gauges in a voltage divider circuit.

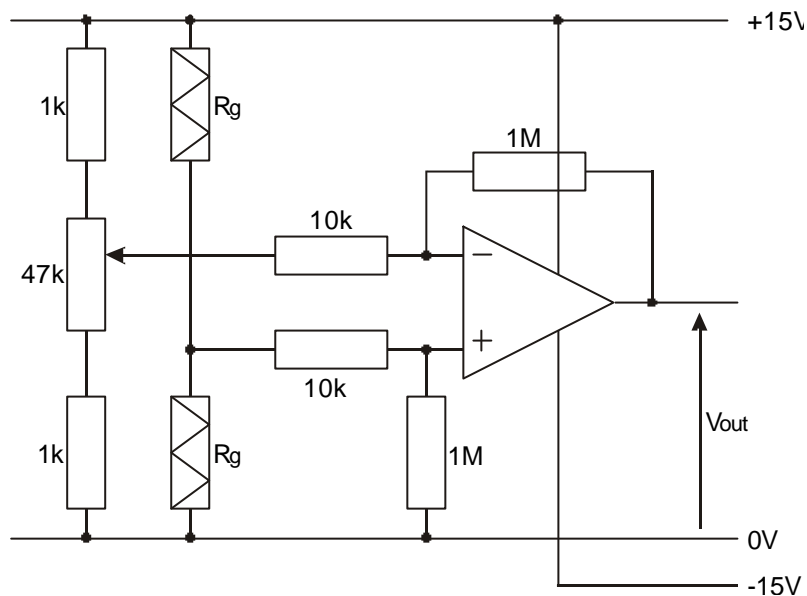

AE. H.LO2. fig 27

Assuming both gauges remain at the same temperature, they will both change resistance by the same amount and therefore the circuit will remain in balance.

Further, if the second gauge is placed beneath the strip, as load is added, the first gauge will be under tension while the second will be in compression. This will have a doubling effect.

END-OF-UNIT ASSIGNMENT

1. An op. amp. is connected as shown in figure Q1.

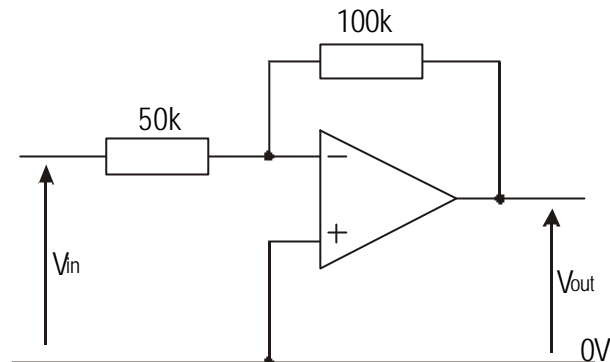

AE.H.LO2. fig Q1

The input to the circuit is monitored by a single beam oscilloscope, figure Q2 shows the screen display and the control settings.

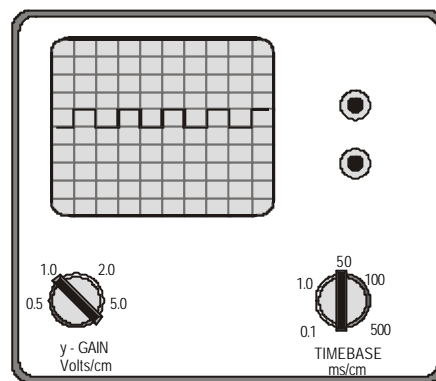

AE.H.LO2. fig Q2

- a) Determine the frequency of the pulses at the input.
 - b) Assuming the oscilloscope controls are not adjusted, redraw the trace you would expect to see if the oscilloscope was connected to the output of the circuit.
 - c) The same components are now used to wire the op. amp. in the non-inverting configuration. Re-draw the new circuit diagram and the you would expect at the output this time.
2. When a tacho generator is rotated, it produces a voltage proportional to it's angular velocity. The tacho is to be used to monitor the speed of coolant flowing along a pipe. If the speed is below a recommended level then an alarm should come on, if the speed is above this level then a green light should come on.
Draw a circuit diagram of the system that could be used and explain how the system works.

3. Part of a disco audio system consists of the microphone connected to a circuit containing two op. amps. as shown in figure Q3

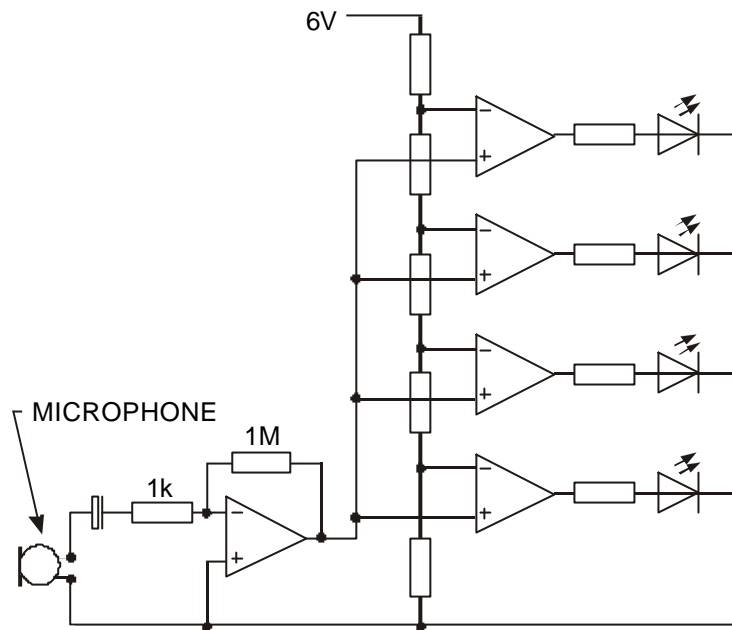

AE.H.LO2. fig Q3

- a) Explain clearly how the circuit operates.
- b) Why are two op. Amps. used in this circuit?
4. A robot is designed to follow a white line painted on the floor. The robot moves by means of suitably geared motors which can be switched on and off independently.

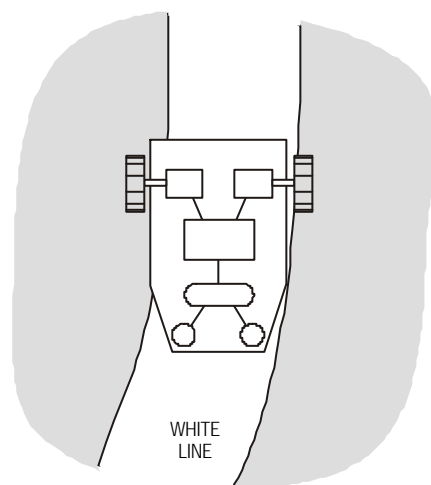

AE.H.LO2. fig Q4

The left sensor controls the right motor (and vice versa). When a sensor detects a white line, the motor is switched on.

- a) Suggest a suitable detector that could be used to detect the white line.
- b) Explain how the robot follows the white line.
- c) Design a suitable circuit that could be used to control one of the motors.

SEB & SQA PAST PAPER EXAM QUESTIONS

1993, Paper 1, question 1

- (a) Name the configuration of the amplifier shown in figure Q1
- (b) Calculate the gain of the amplifier.
- (c) (i) If the input signal V_i is 0.5 V, what is the value of the output signal V_o ?
 (ii) **Explain** your answer.

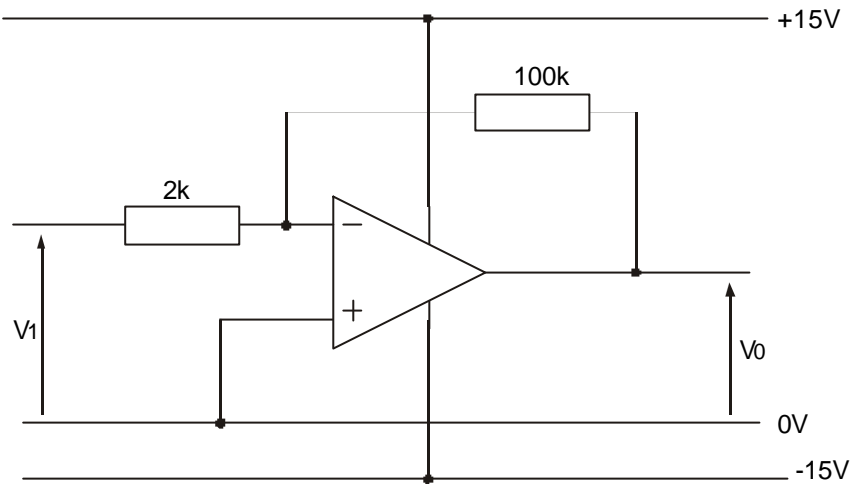

AE.LO2. fig Q1

1997, Paper 1, question 6

Figure Q2 shows an operational amplifier circuit, which includes an ORP12 light dependent resistor as an input sensor.

When the light level on the LDR is 50 lux, determine:

- (a) the resistance of the LDR;
- (b) the voltage gain of the operational amplifier;
- (c) the current flowing through the load resistor R_L , stating clearly the direction in which it is flowing.

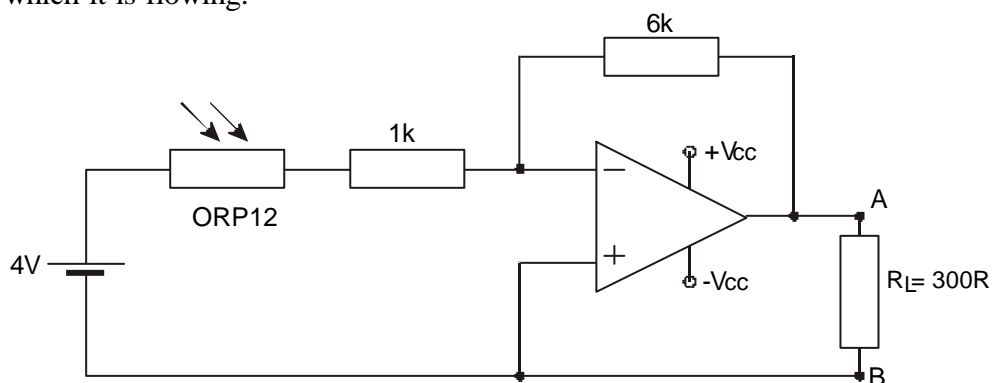

AE.LO2. fig Q2

1994, Paper 1, question 10

A technological experiment involves recording the total effects of light and temperature. It utilises an operational amplifier configured as shown in figure Q3A.

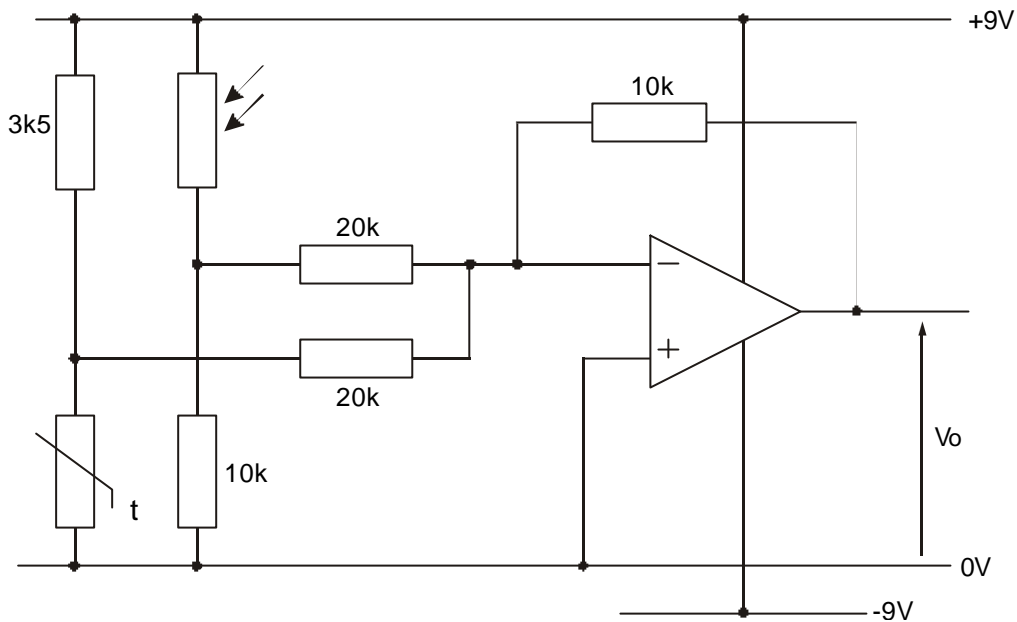

AE.LO2. fig Q3A

- Name the configuration of the amplifier used in the experiment.
- Explain clearly how the system operates.
- Determine the gain of the amplifier.
- Comment on the suitability of the value of the gain in this particular circuit.

The following graph Figure Q3B shows the actual temperature and light readings recorded during the experiment between the hours of 1400 and 2000 on one particular day.

The characteristics of the light dependent resistor and the thermistor used in the circuit are shown in figure Q3C.

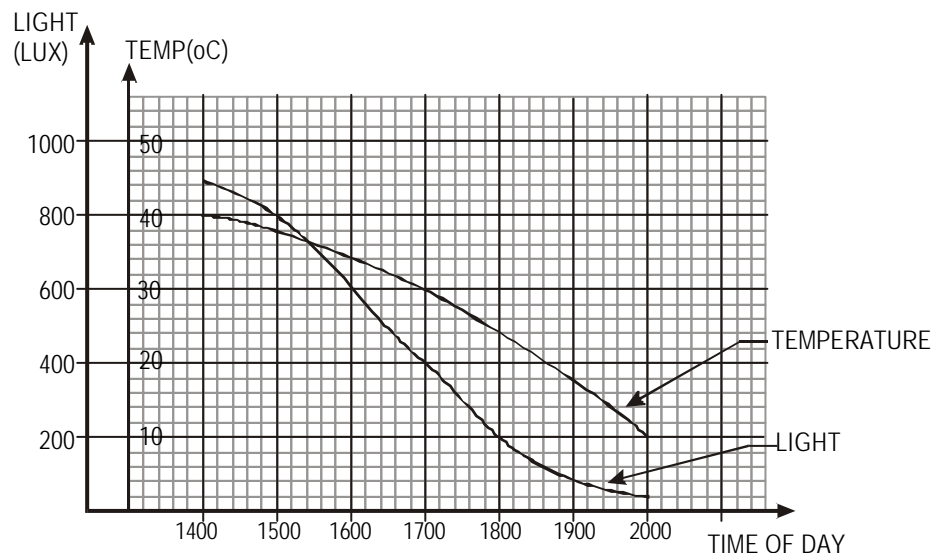

AE.LO2. fig Q3B

- (e) Determine the output voltage (V_o) from the circuit in figure Q3A at 1700 hours.
- (f) For later processing, this value of (V_o) must be positive.
 - (i) Name an additional device which can be added to the circuit to produce a positive value for V_o .
 - (ii) Draw the circuit symbol for this additional device and indicate the value of any components used.

1997, Paper 1, question 9

(part)

A deep-fat fryer incorporates a cooking oil temperature indicator. An array of LEDs is shown on the control panel and, as the temperature of the cooking oil increases, the LEDs light in a ladder sequence. (Figure Q4A)

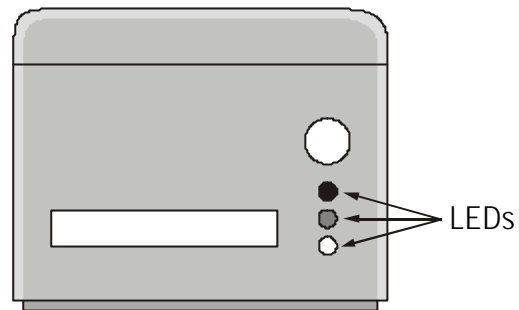

AE.LO2. fig Q4A

The circuit shown in figure Q4B is used to control the lighting of the LEDs. The circuit utilises three 741 operational amplifier ICs and a 151-164 thermistor.

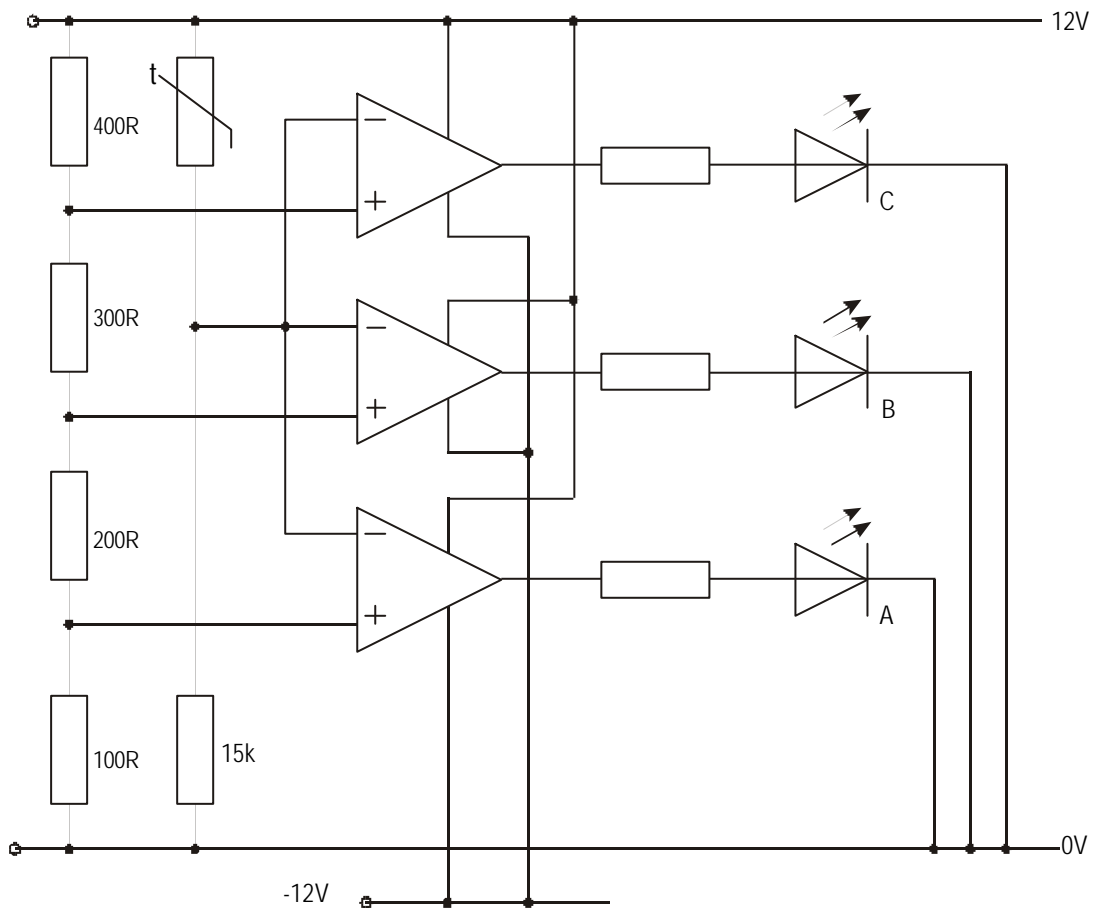

AE.LO2. fig Q4B

- In which amplifier mode are the 741 Ics being used ?
- Explain in detail why the LEDs light up in sequence as the temperature of the oil increases. The function of the components in the circuit should be included in your explanation.
- At what temperature will LED “C” light ?
- If the current through each LED is to be limited to 200 mA, determine what value of resistor should be connected in series with each LED. (Ignore any voltage drop across the LEDs.)

1998, Paper 1, question 7

A camera manufacturer is evaluating a design for a light level indicator, details of which are shown in Figure Q5.

For this circuit, determine the **range** of values of the input voltage V_{in} over which the LED will glow to indicate that a photograph may be taken.

Show all calculations

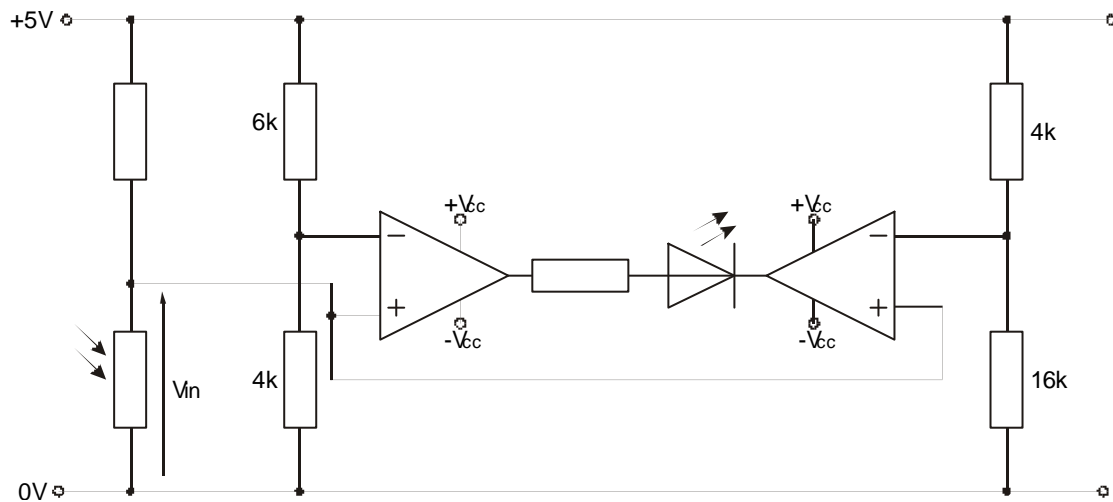

AE.LO2. fig Q5

TECHNOLOGICAL STUDIES

HIGHER

APPLIED ELECTRONICS

SECTION 3

OUTCOME 3

APPLIED ELECTRONICS

Outcome 3 - Design and construct combinational logic systems to meet given specifications

When you have completed this unit you should be able to:

- Identify single logic gate symbols
- Complete Truth Tables for single logic gates
- Analysis Combinational logic circuits
- Complete Truth Tables for combinational logic circuits
- Simplify combinational logic circuits
- Write a Boolean expression for a given logic circuit
- Determine equivalent circuits made from NAND gates
- Identify differences between the TTL and CMOS families of IC's
- Identify types of logic gates, given pin layout diagrams or IC number (logic gate IC's)
- Correctly 'power up' an IC for uses - either diagrammatically or on breadboard
- Using pin diagrams, select correct IC's and be able to form circuits to given specification

Before you start this unit you should have a basic understanding of:

Input and Output transducers.

Voltage divider circuits.

Ohm's Law - relationship between V and I in a d.c. circuit.

The operational characteristics of various electronic components.

Use of breadboards.

Use of circuit test equipment: multimeter and oscilloscope.

BASIC LOGIC GATES

There are seven different logic gates; these are the NOT, AND, OR, NAND, NOR, XOR and the XNOR.

When drawing circuits containing logic gates it is common to use logic symbols. Two sets of symbols might be used.

American Military Symbols (ANSI) Used in this and other countries

British Standard Symbols (BS3939) Used in this country

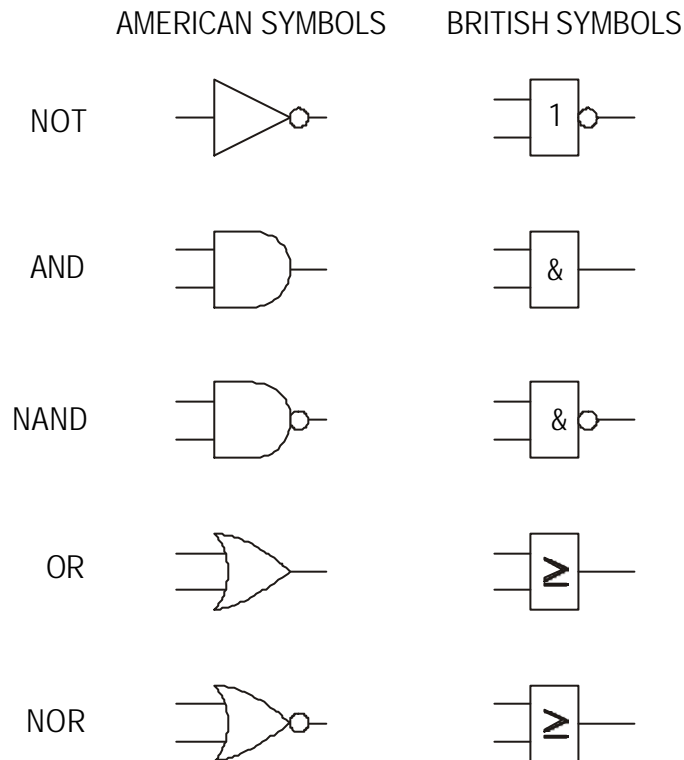

AE.H.LO3. fig1

Throughout this course the more common American symbols will be used. These are the symbols used by the SQA. You should however be familiar with both sets.

Truth Tables

The easiest way to represent how each gate behaves is to make use of Truth Tables. A Truth Table shows all possible combinations of inputs and outputs to a logic gate. Electronics is concerned with the processing of electrical signals.

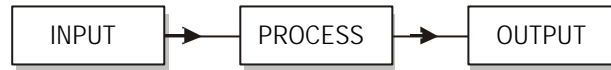

AE.H.LO3. fig 2

Input signals come from a variety of sources - a switch from a keyboard; a bar code reader; a temperature sensor; another part of a computer.

Output signals can have a variety of destinations - a monitor; a modem; an alarm; another part of a computer.

Digital signals can be at a HIGH voltage level or a LOW voltage level.

In logic circuits a LOW signal is said to be at logic '0' a HIGH signal at logic '1'.

The results can be recorded and used in a number of formats, the most common being shown below.

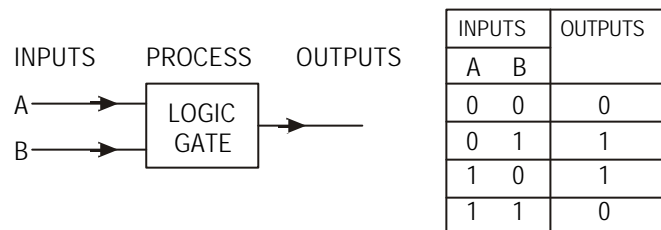

AE.H.LO3. fig 3

Results displayed in this way are known as TRUTH TABLES.

Structure and layout of Truth Tables

Consider the inputs to a logic gate as two switches.

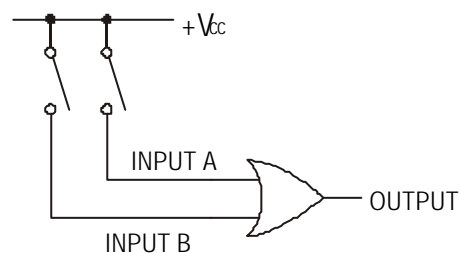

AE.H.LO3. fig 4

It is possible for each switch to be in one of two positions, either, on (1) or off (0). These positions are known as INPUT STATES.

For two inputs, there are only 4 possible combinations of input states:

A-off & B-off; A-off & B-on; A-on & B-off; A-on & B-on.

Input A	Input B
0	0
0	1
1	0
1	1

For three inputs, there are 8 possible combinations.

In general, for **n** inputs there are **2ⁿ** possible combinations of input states (and hence 2ⁿ lines in the truth table.)

ASSIGNMENT 1

1. How many combinations of input states would there be for a 6 input system ?
2. Write down the 8 possible combinations of input states for a 3 input system.

Truth Tables for Individual logic gates

Circuit Simulation Software

It is possible to use circuit simulation software such as 'Crocodile Clips' to investigate electric and electronic circuits.

Collect a copy of the worksheet "Truth tables".

Use 'Crocodile Clips' or another similar software package to determine the truth table for each of the following gates

Use switches at the inputs and an indicator at the output.

(N.B. When the switch or indicator is off, the signal is at logic 0.)

1. NOT gate

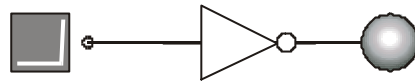

AE.H.LO3. fig 5

2. AND gate

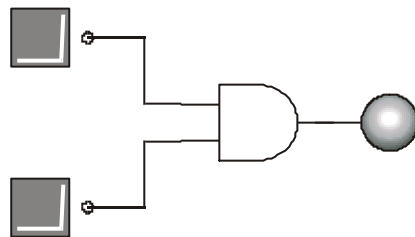

AE.H.LO3. fig 6

3. OR gate

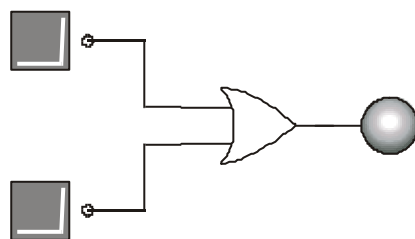

AE.H.LO3. fig 7

4. NAND gate

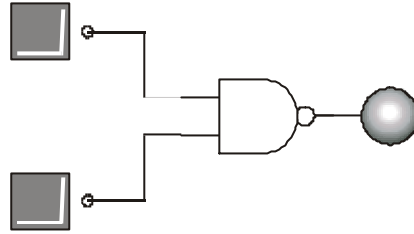

AE.H.LO3. fig 8

5. NOR gate

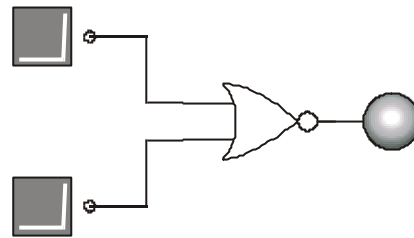

AE.H.LO3. fig 9

6. XOR gate

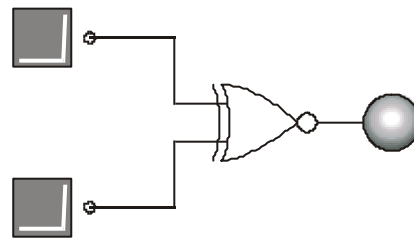

AE.H.LO3. fig 10

ASSIGNMENT 2

1. When is the output of an OR gate high ?
2. When is the output of an AND gate high ?
3. When is the output from an XOR gate high ?
(‘X’ stands for exclusive)
4. Why is the NOT gate sometimes called an ‘INVERTER’ ?

5. The truth table below shows the output conditions for the various combinations of input conditions for AND, NAND, OR and NOR gates.

Inputs	AND	NAND	OR	NOR
0 0	0	1	0	1
0 1	0	1	1	0
1 0	0	1	1	0
1 1	1	0	1	0

How does the output of the NAND gate compare with the output of the AND (and the output of the NOR compare with the OR)

6. The paper can be fed through a computer printer either by pressing the button on the printer (line feed) or by sending a signal from the computer.

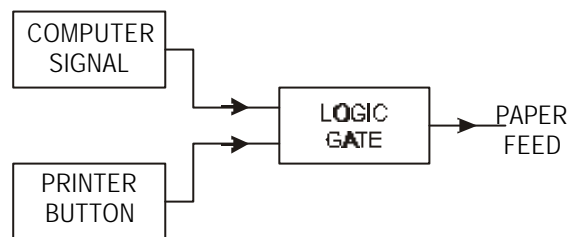

AE.H.LO3. fig 11

Which logic gate should be used for this operation ?

7. The motor in a washing machine should not operate until a high signal is sent from the control program and the water level in the drum is high enough.

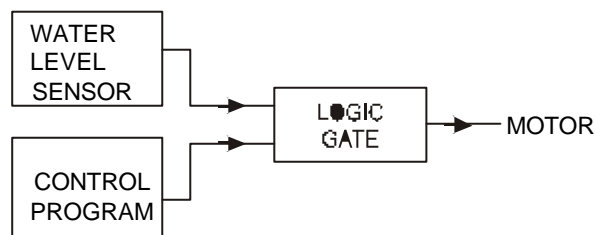

AE.H.LO3. fig 12

Which logic gate should be used for this operation ?

8. To avoid accidents at times of poor visibility, a warning indicator in a car operates if the light level is too low (logic level 0) and the headlamps are switched off.

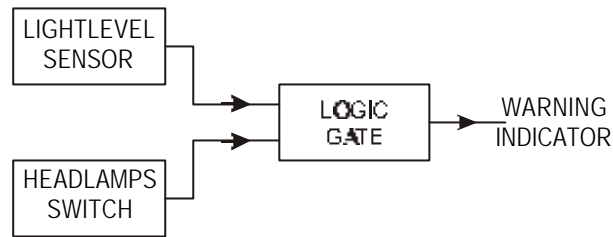

AE.H.LO3. fig 13

Which logic gate should be used for this operation ?

9. In the maternity unit of a hospital, the temperature and pulse rate of premature babies has to be continually monitored. A warning alarm should sound if either the temperature or the pulse rate of the baby falls too LOW.

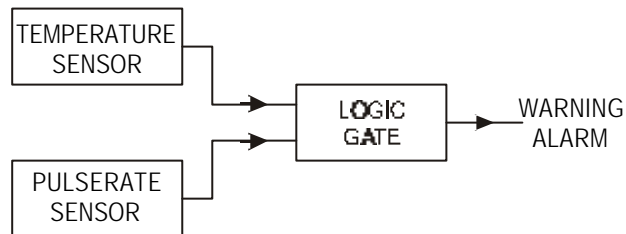

AE.H.LO3. fig 14

Which logic gate should be used for this operation ?

Gate Networks

It is often necessary to use more than one gate to perform a decision process. For example, on some TV sets it is possible to change the channel either by pressing the channel select button on the TV or by pressing the channel select button on the remote control. The channel will only change however, if the TV set is switched on. i.e. The channel will change if the TV set button is pressed **OR** the remote button is pressed **AND** the TV set is on.

A logic diagram for this is shown in figure 15

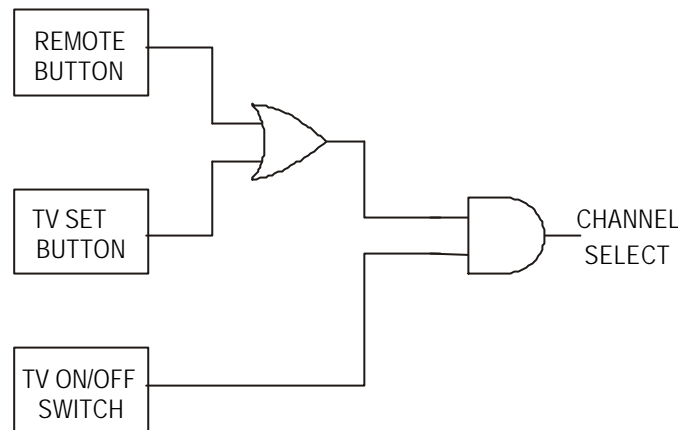

AE.H.LO3. fig 15

Analysing a combinational logic system

COMBINATIONAL LOGIC circuits are those in which the output at any time is determined entirely by the combination of input signals which is present at that time. i.e. the output state does not depend on the sequence of the input signals.

In digital electronics we often encounter systems which will contain several logic gates that have been combined together.

Suppose that you need to know how a particular network will behave for each possible combination of inputs.

If a logic diagram is given, for example:

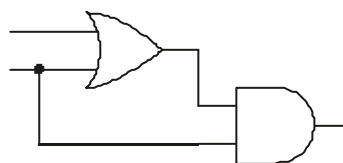

AE.H.LO3. fig 16

STEP 1

Label all the different points on the circuit, including inputs and outputs.
Notice that one input serves two gates, this is quite common in logic circuits and both gates should be labelled accordingly.

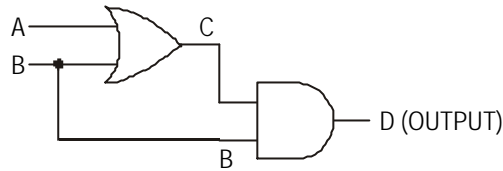

AE.H.LO3. fig 17

STEP 2

Draw up a Truth Table for the circuit, with a different column for each letter.
NB. determine the number of input conditions for the truth table.

two input, therefore $2^2 = 4$

i.e. 4 lines on the truth table.

INPUT		C	OUTPUT
A	B		D
0	0		
0	1		
1	0		
1	1		

STEP 3

Determine what goes into column C. To do this, consider the OR gate on its own, with inputs A and B, enter findings into column C.

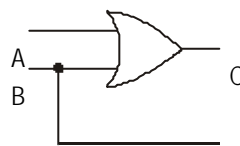

AE.H.LO3. fig 18

INPUT		C	OUTPUT
A	B		D
0	0	0	
0	1	1	
1	0	1	
1	1	1	

STEP 4

Determine what goes into column D i.e.. the output column. Consider the AND gate on its own with inputs from C and B enter findings into column D.

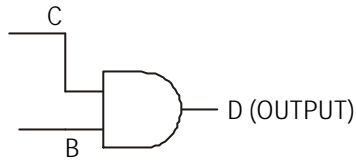

AE.H.LO3. fig 19

INPUT		C	OUTPUT
A	B		D
0	0	0	0
1	1	1	1
0	1	1	0
1	1	1	1

STEP 5

Your final answer should look like this

INPUT		OUTPUT
A	B	
0	0	0
0	1	1
1	0	0
1	1	1

A more complicated system may need several stages before you finish, but if you work systematically through the circuit in the way shown, considering one gate at a time, you should arrive at the correct answer.

ASSIGNMENT 3

Complete a truth table for each of the combinations of gates shown below.

1.

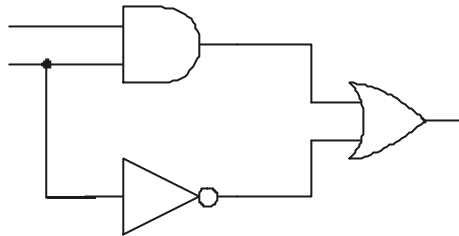

AE.H.LO3. fig 20

2.

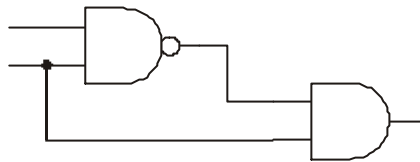

AE.H.LO3. fig 21

3.

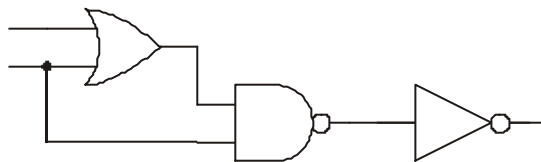

AE.H.LO3. fig 22

4.

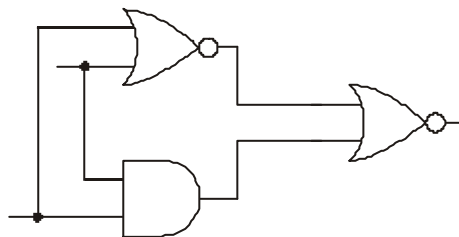

AE.H.LO3. fig 23

5.

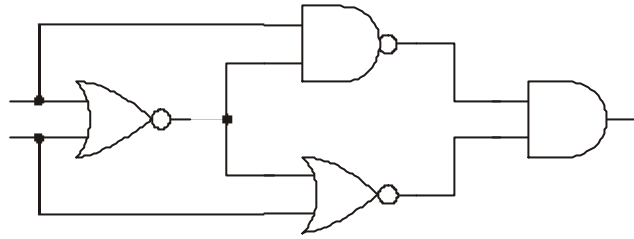

AE.H.LO3. fig 24

Any of the above circuits can be constructed and tested using circuit simulation software such as 'Crocodile Clips'.

NAND EQUIVALENT CIRCUITS

It is possible to make other logic gates (and circuits) by combining NAND gates.

In practice, it is much easier and cheaper to make NAND gates than any others, indeed NAND gates were the first types of gate to be developed into Integrated Circuits (IC's).

Frequently, a circuit will be made entirely from NAND gates. Although it is possible to use NOR gates as the basic logic unit, the industry standard is the NAND gate. The use of only one type of gate to make a circuit often allows us to simplify the wiring of a system and makes more efficient use of an Integrated Circuit.

Most NAND logic gate IC's contain a number of gates - usually four - and cost as little as a few pence for each IC.

The figure below shows a pin layout diagram of a NAND logic gate IC. This IC has 4 independent 2 input NAND gates

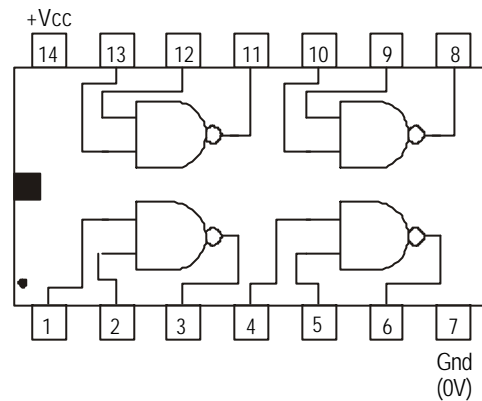

AE.H.LO3. fig 25

The section on IC's will explain in greater detail about the layout and nature of IC's.

METHODS OF MAKING SPECIFIC GATES FROM NANDS

Circuit Simulation Software

It is possible to use circuit simulation software such as ‘Crocodile Clips’ to investigate electric and electronic circuits.

Collect a copy of the worksheet “NAND equivalent circuits” .

Use ‘Crocodile Clips’ or another similar software package to determine the truth table for each of the following network of NAND gates.

Compare the truth table you obtain with truth tables for the individual gates and decide which gate is the equivalent to the NAND network.

(N.B. In some of the networks the two inputs of the NAND gate have been connected together to make a single input.)

1.

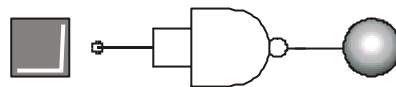

AE.H.LO3. fig 26

2.

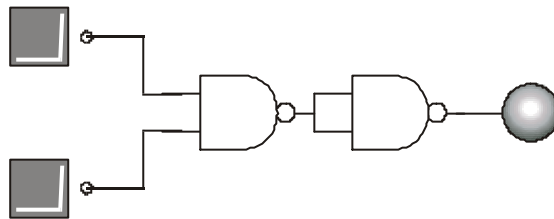

AE.H.LO3. fig 27

3.

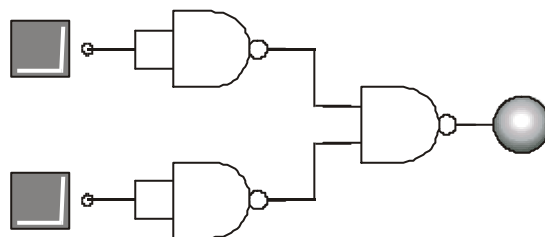

AE.H.LO3. fig 28

4.

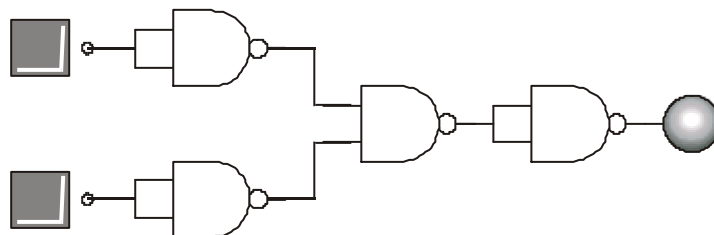

AE.H.LO3. fig 29

Simplification of Combinational Logic Circuits

As has previously been stated it is possible to make all logic circuits from NAND gates only.

This section will examine a method for converting circuits that contain a number of different types of gates into one that uses NAND gates only.

Consider the circuit shown.

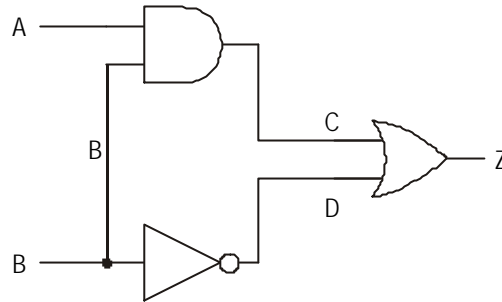

AE.H.LO3. fig 30

The system is made from an AND gate an OR gate and a NOT gate.

The problem is to design a system with the same Truth Table, but made from NAND gates only.

STEP 1

Redraw the circuit, replacing each gate with its NAND gate equivalent.

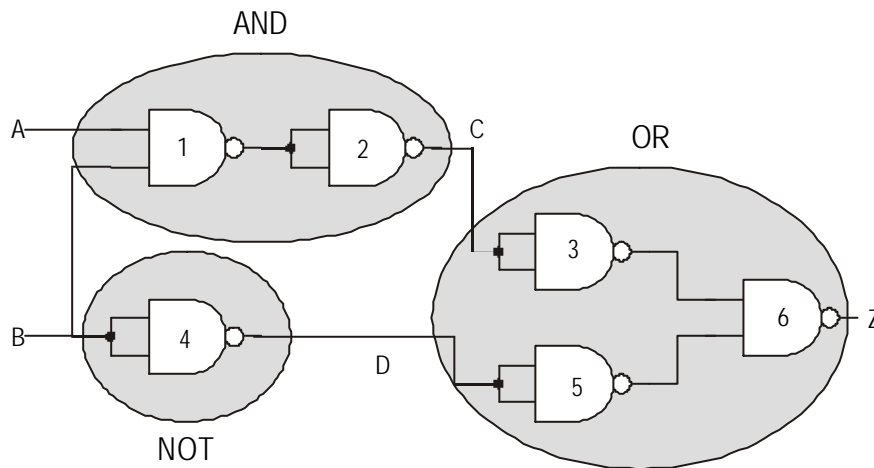

AE.H.LO3. fig 31

STEP 2

Examine the new arrangement and look for adjacent pairs of NOT gates. In this circuit there are two such pairs. (2 & 3 and 4 & 5 are adjacent pairs) If you consider what happens when you feed a signal to a NOT gate then pass the signal on to another NOT gate you will find that the signal has been 'DOUBLE INVERTED' this in fact means that whenever you feed a signal to a pair of NOT gates you will get the same signal out.

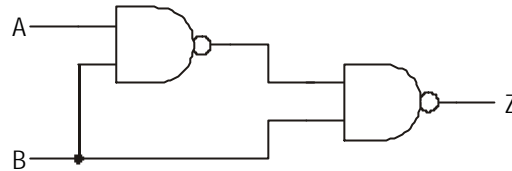

AE.H.LO3. fig 32

Therefore pairs of NOT gates in series can be removed from the system without any effect. (This fact is of considerable importance when we come on to the next section on Boolean algebra.)

STEP 3

Redraw the circuit with the NOT gates removed.

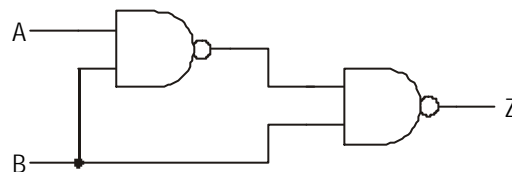

AE.H.LO3. fig 33

The final circuit has only two gates whereas the original circuit started with three gates, each of a different type. There are obvious implications in terms of cost for manufacturers if they are able to reduce logic circuits to situations where there are fewer gates as well as enabling them to use one type of gate. The original circuit would have required three IC's and the final circuit would only require one IC.

This method may not reduce the number of gates used on every occasion but it should reduce the number of IC's used.

This method is not very elegant and can be very demanding in terms of paper use and does not always lead to a very efficient use of NAND gates. The next section on Boolean algebra should allow us to design circuits more effectively and use fewer gates.

ASSIGNMENT 4

The following logic diagrams are constructed from basic gates. Using the method shown, construct equivalent circuits using NAND gates only.

1.

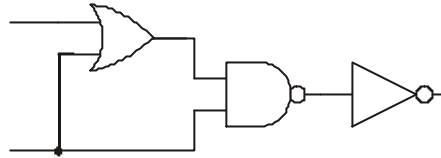

AE.H.LO3. fig 34

2.

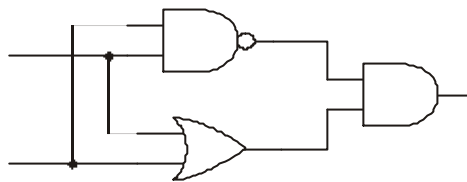

AE.H.LO3. fig 35

3.

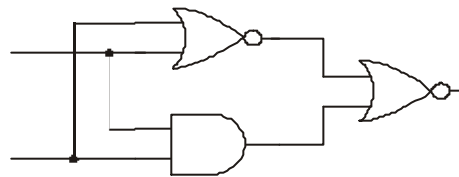

AE.H.LO3. fig 35a

4. a) Construct a truth table for the logic circuit shown.

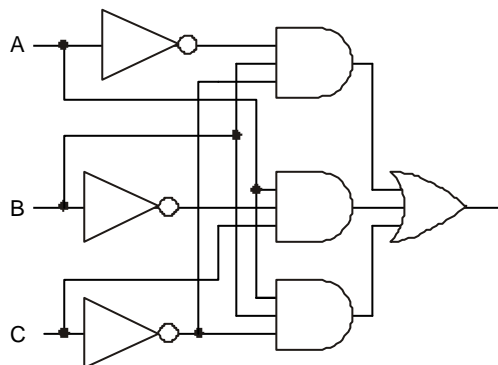

- b) Redraw the circuit using NAND gates only.
- c) Simplify the NAND circuit.
- d) Construct a truth table for the finished NAND circuit.

Boolean Algebra

Boolean algebra is a special form of algebra that has been developed for binary systems. It was developed by George Boolean in 1854 and can be very useful for simplifying and designing logic circuits.

Variables:

The most commonly used variables in logic circuit design are capital letters; such as A, B, C, Z and so on and are used to annotate inputs and outputs to systems. In digital electronics we consider situations where the variables can only have one of two possible values, i.e. 'Logical 0' or 'Logical 1'.

The statement $A = 1$ means that the variable A has the value of Logic 1. Similarly, if $B = 0$ it means that variable B has the value of logic 0.

Logical Operations: In Boolean algebra there are three logical operators, these are the AND operation, the OR operation and the Inversion.

AND Operator

The AND operation can be represented in Boolean notation by

$$A \bullet B = Z$$

The dot between the A and the B is read as AND.

OR Operator

The OR operation can be represented in Boolean notation by

$$A+B = Z$$



The + between the A and the B is read as OR.

Inversion Operator

The statement $\bar{A} = Z$ means that Z is not equal to A.

The variable is read as A bar and usually means NOT A. The bar over the top of the variable changes its value, or inverts it. This is known as the NOT operation.

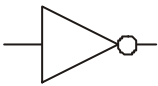
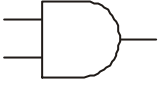
Basic logic gates and their Boolean representations

LOGIC SYMBOL	BOOLEAN EXPRESSION	DESCRIPTION	TRUTH TABLE															
<p>NOT</p> 	$\bar{A} = Z$	NOT A EQUALS Z	<table border="1"> <thead> <tr> <th>A</th> <th>Z</th> </tr> </thead> <tbody> <tr> <td>0</td> <td>1</td> </tr> <tr> <td>1</td> <td>0</td> </tr> </tbody> </table>	A	Z	0	1	1	0									
A	Z																	
0	1																	
1	0																	
<p>AND</p> 	$A \cdot B = Z$	A AND B EQUALS Z	<table border="1"> <thead> <tr> <th>A</th> <th>B</th> <th>Z</th> </tr> </thead> <tbody> <tr> <td>0</td> <td>0</td> <td>0</td> </tr> <tr> <td>0</td> <td>1</td> <td>0</td> </tr> <tr> <td>1</td> <td>0</td> <td>0</td> </tr> <tr> <td>1</td> <td>1</td> <td>1</td> </tr> </tbody> </table>	A	B	Z	0	0	0	0	1	0	1	0	0	1	1	1
A	B	Z																
0	0	0																
0	1	0																
1	0	0																
1	1	1																
<p>OR</p> 	$A + B = Z$	A OR B EQUALS Z	<table border="1"> <thead> <tr> <th>A</th> <th>B</th> <th>Z</th> </tr> </thead> <tbody> <tr> <td>0</td> <td>0</td> <td>0</td> </tr> <tr> <td>0</td> <td>1</td> <td>1</td> </tr> <tr> <td>1</td> <td>0</td> <td>1</td> </tr> <tr> <td>1</td> <td>1</td> <td>1</td> </tr> </tbody> </table>	A	B	Z	0	0	0	0	1	1	1	0	1	1	1	1
A	B	Z																
0	0	0																
0	1	1																
1	0	1																
1	1	1																

AE.H.LO3. fig 36

NAND gate

The NAND gate is made up from a combination of an AND gate followed by a NOT gate.

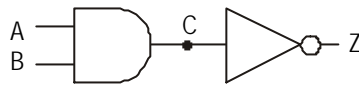

AE.H.LO3. fig 37

The signal at point C would be $A \bullet B$. This signal is then inverted by the NOT gate to give

$$\overline{A \bullet B} = Z$$

This reads as output Z is equal to A AND B all NOT

NOR gate

The NOR gate is made up from a combination of an OR gate followed by a NOT.

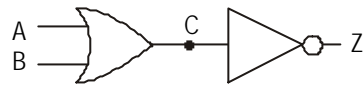

AE.H.LO3. fig 38

The signal at point C would be A+B. This signal is then inverted by the NOT gate to give

$$\overline{A + B} = Z$$

This reads as output Z is equal to A OR B all NOT

ASSIGNMENT 5

Write down the Boolean expression for each of the following logic gates.

a)

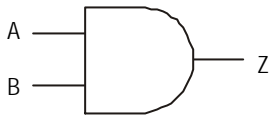

b)

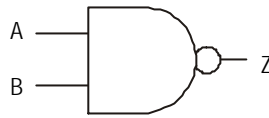

c)

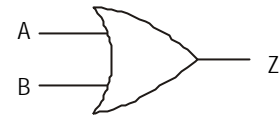

d)

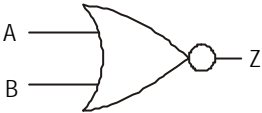

e)

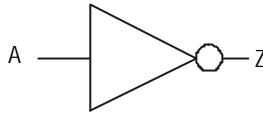

f)

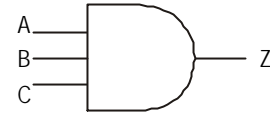

g)

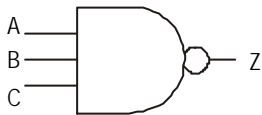

h)

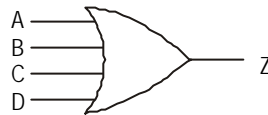

i)

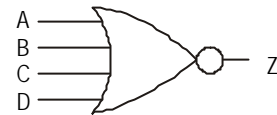

AE.H.LO3. fig 39

Laws of Boolean Algebra

The following is a summary of the basic laws of Boolean algebra. These are the most commonly used laws. Your teacher will assist you if you require further information.

NB. It is essential to understand whilst undertaking analysis using Boolean that you must not confuse the symbols used for the Logical operators with those used in normal algebra.

It is perhaps useful to know that the rules of common algebra are the same as those of Boolean.

- + represents logical operator OR
- represents Logical operator AND
- \bar{A} represents A bar i.e. NOT A (the inverse of A)

Deriving the Boolean expression for a circuit

Consider the following circuit.

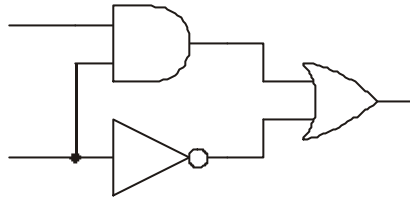

AE.H.LO3. fig 39a

The Boolean expression for the circuit can be derived as follows:

STEP 1

Label the inputs on the left-hand side of the diagram.

(If one input serves more than one gate ensure that the input is labelled accordingly).

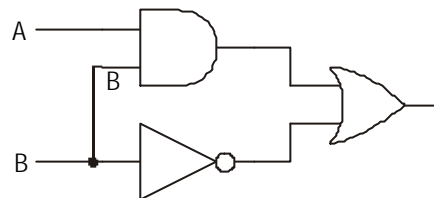

AE.H.LO3. fig 40

STEP 2

Consider each gate in turn. Use the Boolean notation (operators) to give the output of each gate in terms of its input.

Write on the appropriate expression after each gate.

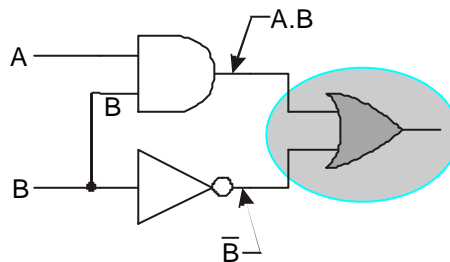

AE.LO3. fig 40a

STEP 3

When outputs from other gates are inputs to a further gate, treat the expressions as you would any other equation and make use of brackets (if necessary). Then write on the appropriate expression after the next gate and so on until you reach the final output.

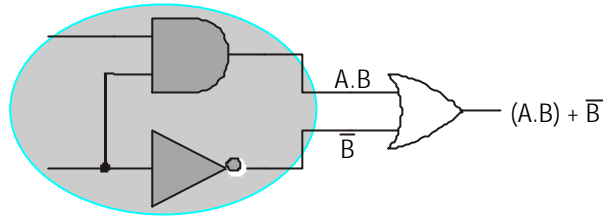

AE.H.LO3. fig 41

STEP 4

Write down the final Boolean expression for the network.

$$(A \bullet B) + \bar{B} = Z$$

(Since normal rules of algebra hold, $\bar{B} + (A \bullet B) = Z$ would also be correct)

ASSIGNMENT 6 a

1. Derive the Boolean expression for each of the following circuits:

a)

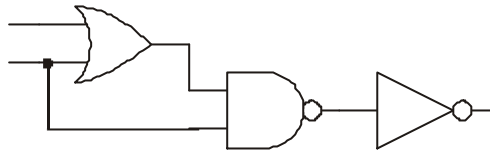

b)

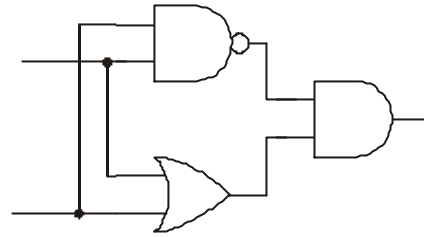

c)

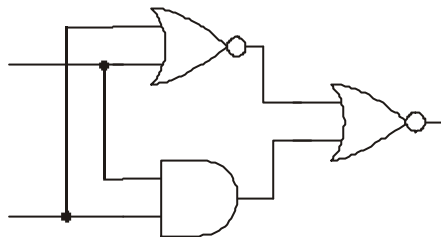

d)

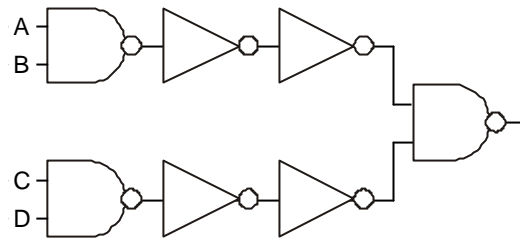

e)

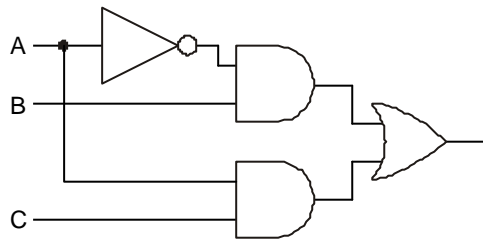

f)

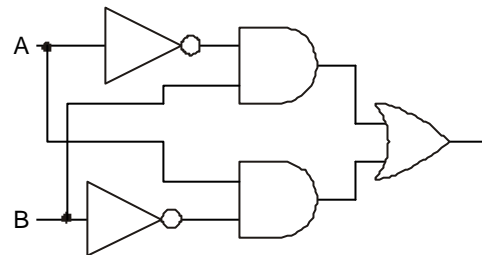

2. Draw a gating arrangement to illustrate $Z = A \bullet B + C$

3. Draw a logic diagram to yield $D = B + C$

Develop it to obtain $Z = A \bullet D$

Write a Boolean equation for the overall behaviour.

4. Derive the Boolean equation and the truth table the following arrangements:

a)

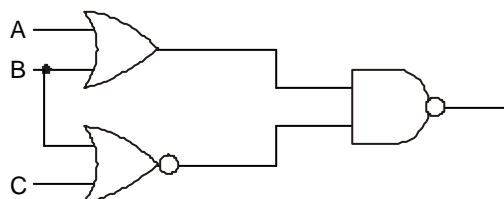

b)

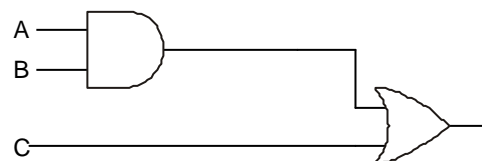

5. For each pair of circuits shown below:

- (i) Write a Boolean expression for each of these circuits;
- (ii) By constructing a truth table for each of them, show that they are equivalent;
- (iii) Draw the equivalent arrangements using only 2-input NAND gates.

a)

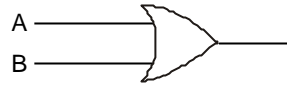
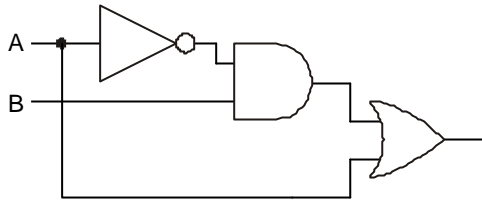

b)

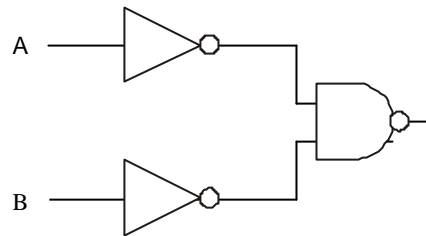
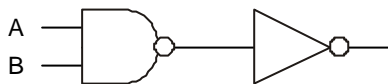

c)

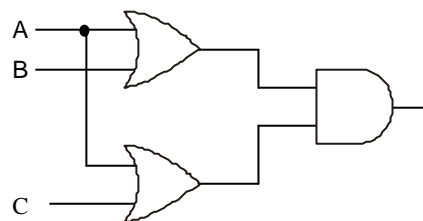
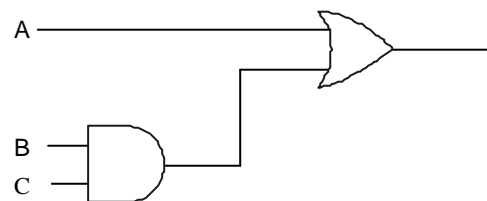

AE.H.LO3. fig 42

Deriving the Boolean expression from a Truth Table

Consider the Truth Table given

A	B	Z
0	0	1
0	1	0
1	0	1
1	1	1

STEP 1

Note each combination that will give you a '1' at the output and write the Boolean expression for this line at the side of the Truth Table, next to the line that it applies to.

A	B	Z	
0	0	1	$\overline{A} \cdot \overline{B}$
0	1	0	
1	0	1	$A \cdot \overline{B}$
1	1	1	$A \cdot B$

STEP 2

Join the equations by putting an OR sign between each to give the final Boolean expression.

$$(\overline{A} \cdot \overline{B}) + (A \cdot \overline{B}) + A \cdot B = Z$$

ASSIGNMENT 6 b

2. Write the Boolean equation for the following truth tables

a)

A	B	Z
0	0	0
0	1	1
1	0	1
1	1	0

b)

A	B	C	Z
0	0	0	0
0	0	1	0
0	1	0	1
0	1	1	1
1	0	0	0
1	0	1	1
1	1	0	0
1	1	1	1

2. Develop a Boolean equation and draw a logic circuit diagram containing AND, OR and NOT gates to yield the truth table shown.

A	B	C	Z
0	0	0	0
0	0	1	1
0	1	0	1
0	1	1	0
1	0	0	1
1	0	1	0
1	1	0	0
1	1	1	0

Designing a circuit from its Boolean equation

Consider the following equation

$$\bar{A} \cdot \bar{B} + A \cdot \bar{B} + A \cdot B = Z$$

STEP 1

Draw inputs A and B (and any other input variables) on the left-hand side of the page.

A

B

STEP 2

Start by considering the first term

$$\bar{A} \cdot \bar{B}$$

It can be seen from the equation that both inputs require to be inverted. This is achieved by passing signals from A and B through NOT gates. The output from these signals are then used as inputs to an AND gate (as signified by the dot between the A and B in the Boolean expression).

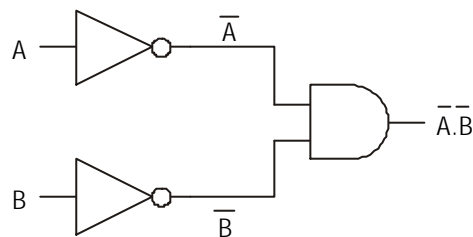

AE.H.LO3. fig 43

Write this on the output line of the AND gate.

STEP 3

Consider the next term

$$A \cdot \bar{B}$$

It can be seen from this term that input A does not require to be inverted but input B does. Since we already have both input A and B bar available we can amend the circuit diagram accordingly by feeding these inputs to a second AND gate.

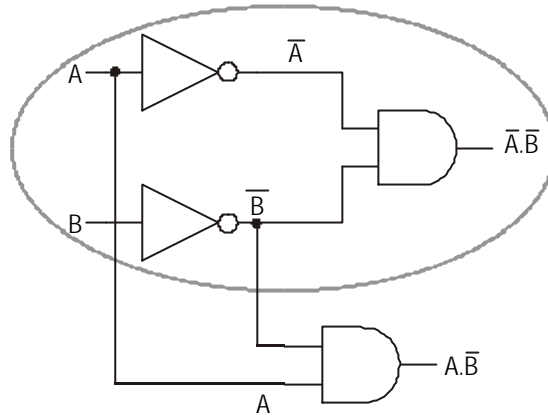

AE.LO3. fig 44

STEP 4

Consider the final term

$$A \cdot B$$

Again both inputs are available to us. Neither of the inputs is inverted so the signals are taken from the original inputs and are fed to a third AND gate.

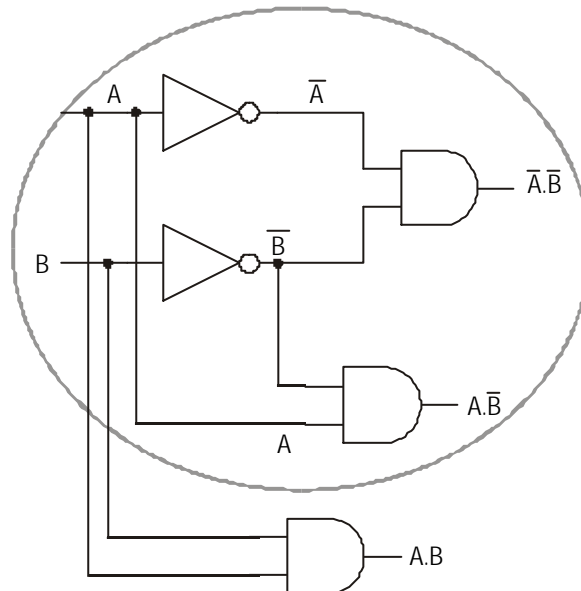

AE.H.LO3. fig 45

STEP 5

Finally we use the outputs from the three AND gates as inputs to a three input OR gate to arrive at the final solution.

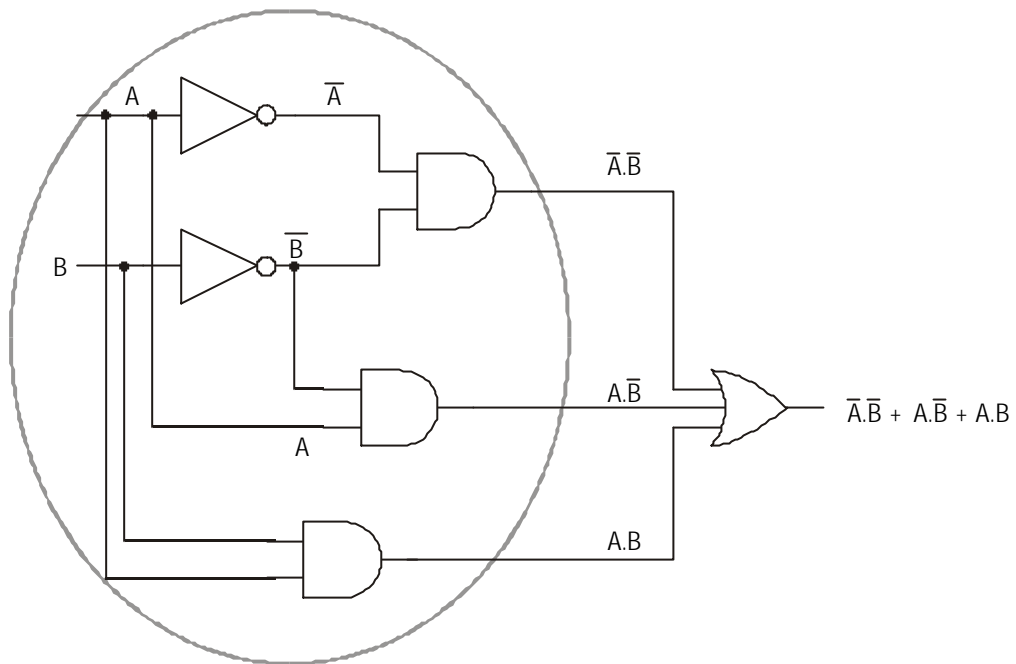

AE.H.LO3. fig 46

ASSIGNMENT 7

2. For the following Boolean equations, draw the correct logic circuit arrangement.

- a) $A + A \bullet B = Z$
- b) $A + \overline{B} + C = Z$
- c) $A \bullet B + A \bullet C = Z$
- d) $A \bullet B + \overline{A} \bullet C + B \bullet C = Z$
- e) $A \bullet B \bullet C + D \bullet E + F \bullet G$

Combinational logic circuit design

As problems become more and more difficult it is not always possible to go from the question to the answer in one or two steps, when that is the case the following set of rules should be followed.

When designing a system to suit a need you should proceed in the following order.

1. Describe the problem clearly in words.
2. Write out a Truth Table for the system.
3. Derive the Boolean expression from the Truth Table.
4. Simplify this expression if possible.
5. Draw a logic circuit diagram for the system using AND, OR and NOT gates.
6. Convert the circuit to NAND gates only.

It is entirely possible that not every problem will require all of these steps to be followed, however this will be a useful guide for most.

WORKED EXAMPLE:

The temperature in a manufacturing process is critical.

A sensor is used to detect overheating. The sensor normally records a 0 logic level, but when it overheats it records a logic level 1.

The signals are detected on a control panel. On the control panel, under normal conditions, a green light is on. If the temperature gets too high the green light goes off and a red light comes on and a warning bell sounds.

The engineer has a switch to cut out the bell, but leaving the red light on. The switch is used when the engineer has noticed the fault on the panel.

This system has two inputs (4 possible combinations) and three outputs (green light, red light and bell).

1. Describe the problem clearly in words.

Let the temperature sensor be input A and the fault acknowledge switch as input B.

Green light is on if: A is 0 AND B is 0
 OR A is 0 AND B is 1

The second condition occurs if the engineer acknowledges a fault when there is no fault.

The bell rings when: A is 1 AND B is 0

The red light is on when: A is 1 AND B is 0
 OR A is 1 AND B is 1

2. Write out a Truth Table for the system.

Inputs		green light	red light	alarm bell
A	B			
0	0	1	0	0
0	1	1	0	0
1	0	0	1	1
1	1	0	1	0

3. Derive the Boolean expression from the Truth Table.

Inputs		green light		red light		alarm bell	
A	B						
0	0	1	$\bar{A} \bullet \bar{B}$	0		0	
0	1	1	$\bar{A} \bullet B$	0		0	
1	0	0		1	$A \bullet \bar{B}$	1	$A \bullet \bar{B}$
1	1	0		1	$A \bullet B$	0	

4. Simplify the expressions if possible.

$$\text{green light} - (\bar{A} \cdot \bar{B}) + (\bar{A} \cdot B) = Z$$

It can be seen that the output does not depend on the state of B since the output is HIGH when B is either HIGH or NOT HIGH i.e. the state of the green light depends only on the state of A, hence the expression can be simplified to

$$\text{green light} - \bar{A} = Z$$

$$\text{red light} - (A \cdot \bar{B}) + (A \cdot B) = Z$$

Similarly it can be seen that the red light is ON irrespective of the state of B - the output only depends on the state of A hence this can be simplified to

$$\text{red light} - A = Z$$

$$\text{alarm} - A \cdot \bar{B} = Z \text{ (can't be simplified further)}$$

5. Draw a logic circuit diagram for the system using AND, OR and NOT gates. Start with the expression that has fewest terms/gates (in this case $A=Z$, no gates!)

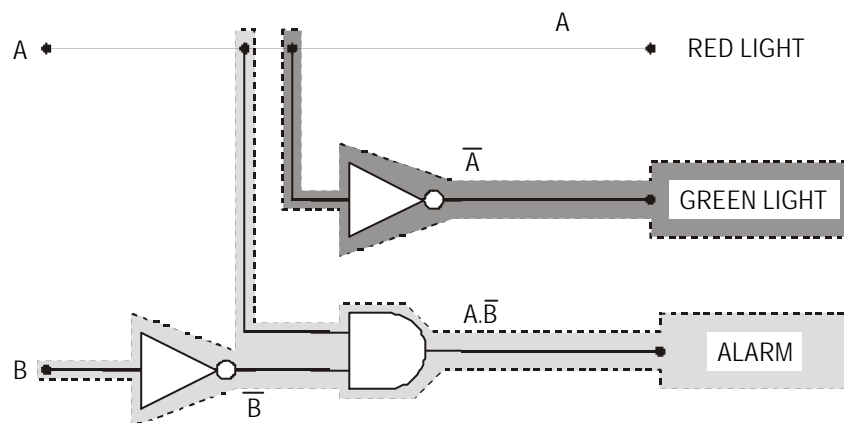

AE.H.LO3. fig 47

6. Convert the circuit to NAND gates only. (Look for double inverted signals which can be cancelled out.)

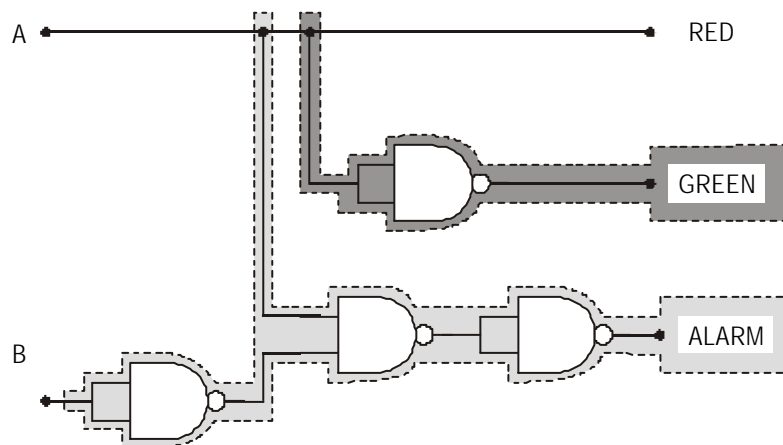

AE.H.LO3. fig 48

ASSIGNMENT 8

1. An electric guillotine must be adequately guarded. In order to safeguard the operator the machine has two switches, A and B, set about one metre apart, both of which need to be pressed before the machine will operate.
Design a logic circuit that will give a green light if, both switches are not pressed and both switches are pressed. If only one switch is pressed a red light should come on.
Assume that the switches return a 0 when not pressed and a 1 when pressed.

2. A given logic circuit has two logic inputs A and B. It is required to produce two logic outputs X and Y according to the following rules:

1. X is to be at logic 1 if (A OR B) but NOT (A AND B) are at logic 1.
2. Y is to be at logic 1 if (A AND B) but NOT (A OR B) are at logic 1.

Use the previous method to design an appropriate logic circuit.

3. A garage door is operated by a motor which is controlled by three switches. The motor runs either:
when a pressure pad switch, A, in the drive is closed and a light dependent resistor switching circuit, B, is simultaneously activated by the car's headlights
or
when the keyswitch, C, in the garage door is operated.
 - a) Prepare a truth table for all possible combinations of switching conditions for switched A, B and C. Take switch open as logic 0.
 - b) From the truth table, prepare a logic diagram using the least number of gates.
 - c) Redesign your circuit to use only 2-input NAND gates.
4. A domestic burglar alarm system is designed such that a bell will operate when the power switch is closed and a pressure switch under a carpet is closed or a switch is opened as a window is lifted.
 - a) Assuming all switches to be logic state zero (0) when open
 - i) Draw a logic diagram for the design, allocating capital letters to the inputs to each gate and to the output to the bell.
 - ii) Prepare a truth table for the design. Your table must be headed by the appropriate letters
 - b) Show by use of a logic diagrams how you would modify or combine 3-input NAND gates to provide AND and OR gates.

5. The diagram below shows part of an industrial control system having three inputs A, B and C with an output G.

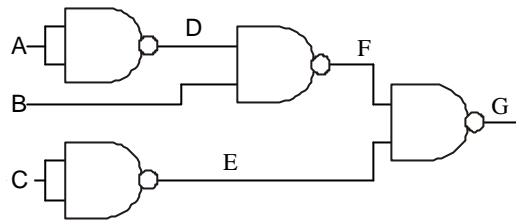

- How many different input conditions are possible in this system ?
- What is the function of gates 1 and 2 ?
- Complete a truth table including columns which show the states of D, E, F and G.
- Why is the design made up entirely of NAND gates ?
- Give an alternative design using 3-input AND and OR gates.

INTEGRATED CIRCUITS

In digital electronic circuits, logic gates are normally manufactured onto an integrated circuit (IC). An IC can, and more often does, contain more than one logic gate. IC's can be found in a wide variety of packages. The most common is the plastic DIL (Dual In Line) pack, where the silicon chip is enclosed in the plastic case with connecting pins to provide connections to the appropriate gates. Here the pins run down either side of the plastic package as shown below. The number of pins can be a 8, 14, 16, 18, 20, 24, 40 and even 60 pin.

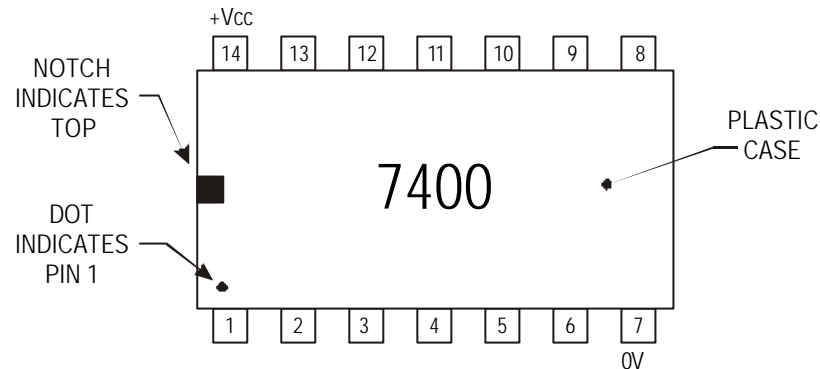

AE.H.LO3. fig 49

Pin numbering starts with pin 1 that is always below the notch or identifying circle. The numbering then goes round in an anti-clockwise direction.

Advantages of Integrated Circuits:

Integrated circuits have the following advantages over discrete components.

1. They are smaller and lighter.
2. They are cheaper than discrete components due to manufacturing techniques and scale of integration (the number of components on each chip).
3. More reliable and easier to replace.

Types of Integrated Circuits available (Logic Families):

There are two main methods of producing electronic logic devices today, giving two families of logic and these are MOS and TTL.

MOS Logic Devices

MOS stands for Metal Oxide Silicon. MOS devices use field effect transistors (FET's) to make up the gates. Various types of MOS are in use:

CMOS - Complimentary Metal Oxide Silicon referring to the fact that complimentary p-type silicon and n-type silicon channels are used.

PMOS - Where the channel is made from p-type silicon.

NMOS - Where the channel is made from n-type silicon.

TTL Logic Devices

TTL stand for Transistor - Transistor Logic. These devices use bipolar transistors to make up the gates

Most switching gate circuits use either Transistor - Transistor Logic (TTL) or Complimentary Metal Oxide Silicon (CMOS) gates.

TTL gates are available commercially in the 7400 series and CMOS IC's are available in the 4000 series.

Comparison of CMOS and TTL devices.

The table compares the two types of logic IC's.

Property	CMOS	TTL
Supply voltage	3 - 15 V (18Vmax)	5 V \pm 0.25V
Current required	8 mA	3 mA
Switching speed	slow	fast
Fan out	50	10

NB. A new hybrid chip is available on the market that has the advantages of both types and is listed as the 74HCT00 series. The 74HCT series is a high speed CMOS semiconductor and has all the advantages of high speed CMOS but with inputs configured for direct drop-in replacement of TTL. It operates in the voltage range 2-6V dc.

CMOS - Advantages

1. The main advantage of CMOS devices is that they will operate on any d.c. voltage in the range 3V-15V (18V max).
2. They have a low current drain, usually in the order of a few microamps.
3. They have low power consumption.
4. They have a high FAN OUT, usually in the order of 50 (the ability of the output of a gate to drive a number of similar inputs to other gates).
5. CMOS has very good noise immunity.

CMOS - Disadvantages

1. The major disadvantage of CMOS is its slower switching speed, usually in the order of 2 to 4 MHz. (4×10^6 switches per second)
2. CMOS devices can easily be destroyed by static electricity (in order to protect them from static, when in use, all unused inputs should be connected to either the zero volt line or the positive line).

Recent developments in MOS technology have seen major improvements in the areas of speed, with the latest MOS devices claiming speeds similar to TTL.

TTL - Advantages

1. The major advantage of TTL devices is their high switching speeds, usually in the order of 50 MHz (50×10^6 switches per second)
2. No damage is done to TTL devices if inputs are left unconnected. (Such inputs will set to +5V)

TTL - Disadvantages

1. TTL devices are much less flexible in terms of their operating conditions than corresponding CMOS devices.
2. Requires a stabilised voltage supply in the range +5V + or - 0.25V (usually expensive).
3. The fan out is 10.
4. Higher power consumption than CMOS devices.
5. High current drain, usually in the order of a few milliamps.

The latest designs of TTL devices are combining higher and higher switching speeds with lower power dissipation.

In this course we will be using TTL logic gates for demonstrations and practical work, since they are more robust and we can leave the unused inputs floating.

Identifying Integrated Circuits

The pin diagram for a 7408 TTL logic gate is shown below.

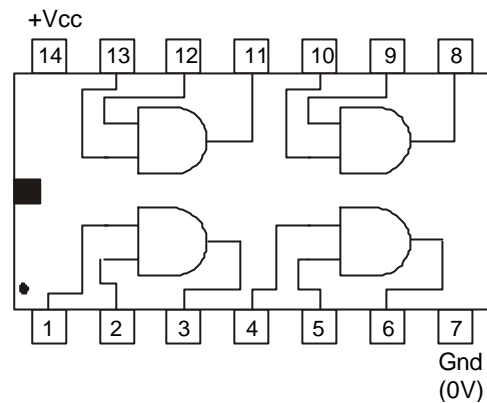

AE.H.LO3. fig 50

The 7408 IC is described as a quad two-input AND gate device.

The quad part indicates how many gates of the type are on the device and the two-input part refers to the fact that each AND gate has two inputs.

Other examples of TTL devices can be found in suppliers' catalogues such as RS Components.

EXAMPLES OF PIN LAYOUT DIAGRAMS.

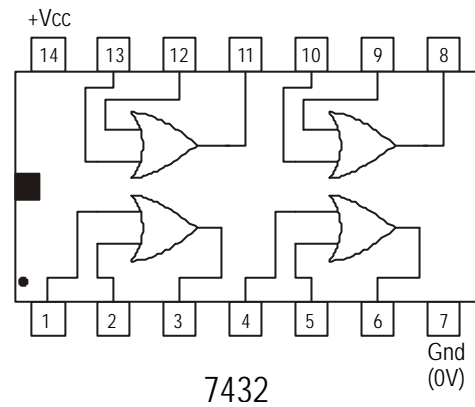
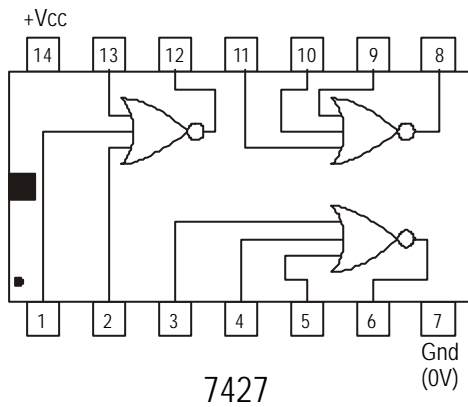
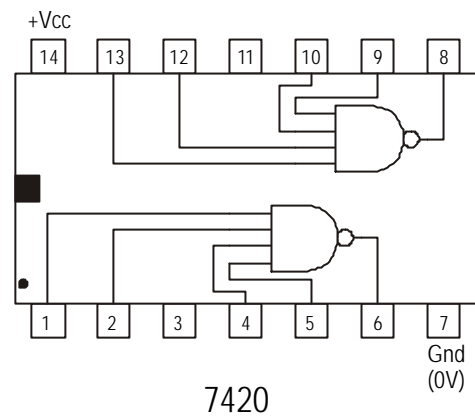
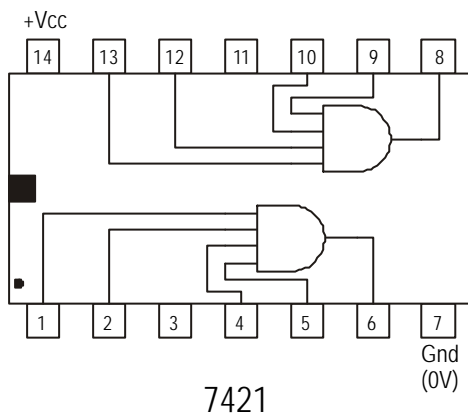
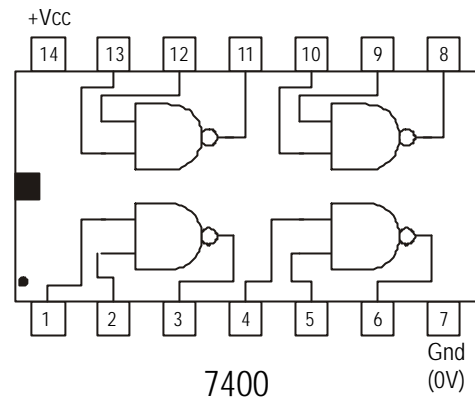
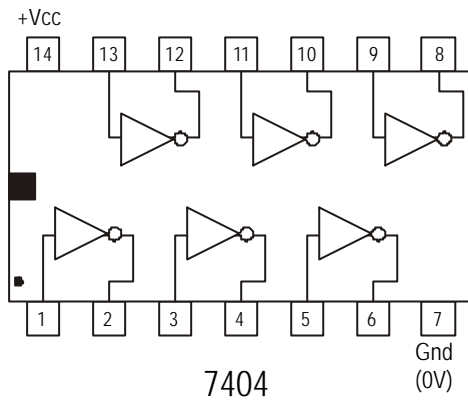

AE.H.LO3 fig 51

ASSIGNMENT 9

- a) Which of the above IC's contain AND gates.
- b) Which IC contains 4 input NAND gates.
- c) Which IC contains NOT gates.
- d) What type of gate is contained in the 7400 IC.
- e) Which IC's would be required to construct the following circuits.

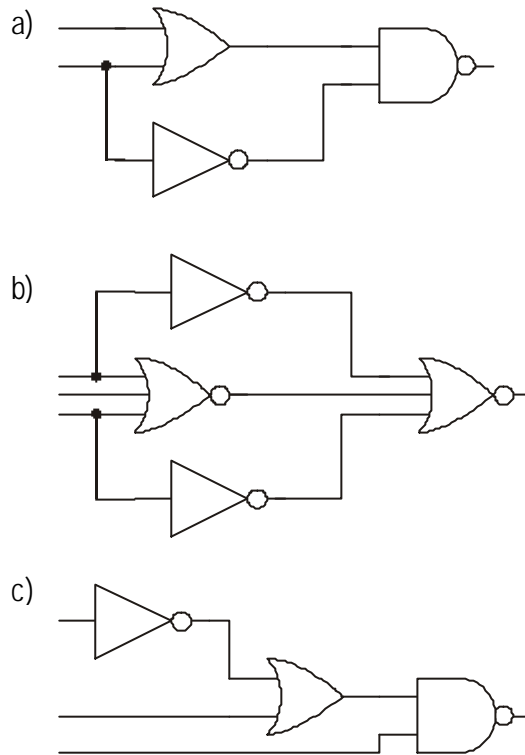

AE.H.LO3. fig 52

IC circuit diagrams

The following logic circuit could be constructed using IC's

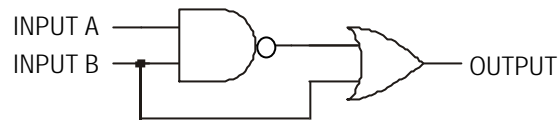

AE.H.LO3. fig 53

Since the gates within an IC are identical, any one of them can be used

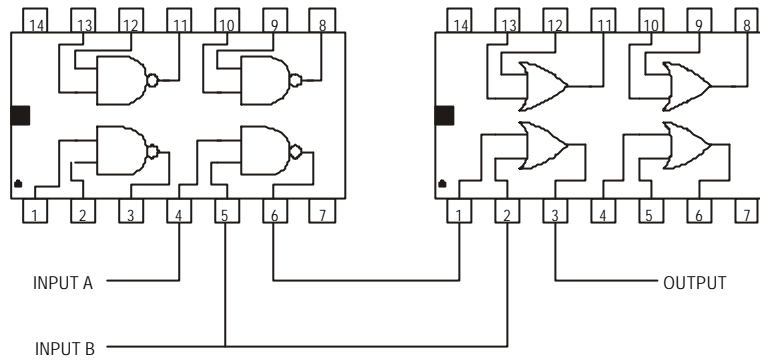

AE.H.LO3. fig 54

ASSIGNMENT 10

- The following circuit contains a 7404 and a 7400 IC.
By referring to pin diagrams, draw the corresponding logic circuit.

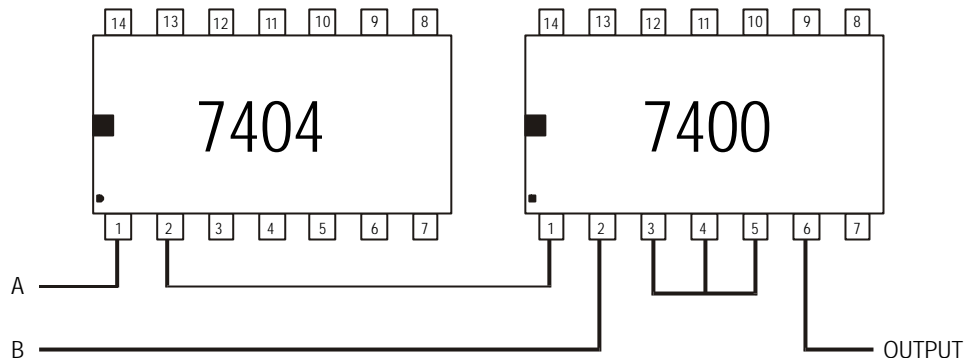

AE.H.LO3. fig 55

- Draw the corresponding logic diagram for the circuit shown below.

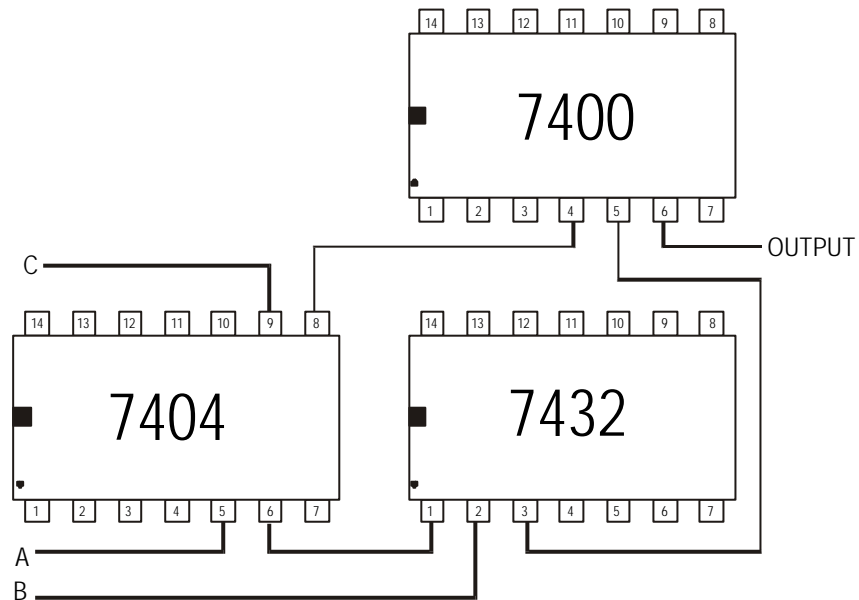

AE.H.LO3. fig 56

Practical IC circuits

The following section deals with the construction of circuits containing IC's. You will need the following equipment.

1. Breadboard.
2. 0.7mm solid core insulated wire.
3. Various IC's (TTL)only.
4. One red led.
5. One 330 R resistor.
6. 5V regulated supply.
7. Three push switches.
8. A logic probe.

Pin layout diagram

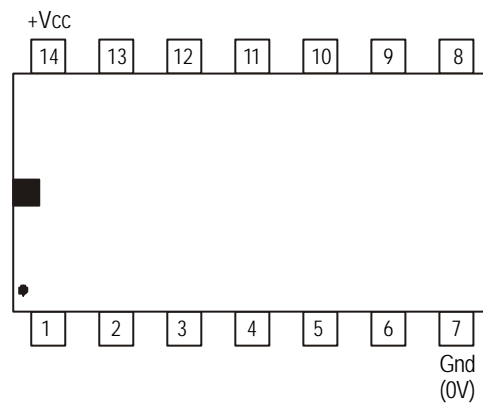

AE.H.LO3. fig 57

The pin layout diagram of a TTL IC is shown above, as previously mentioned, the orientation of the IC is determined from the location of the notch, which indicates the top and the dot that indicates pin 1.

In TTL logic gates, pin 7 is always the ground pin and pin 14 is always the +ve pin, i.e. pin 7 should always be connected directly to 0V or ground and pin 14 should always be connected directly to +5V.

ASSIGNMENT 11

1. Construct the following circuit using a 7402 IC, two push switches as inputs and an led to indicate the state of the output.

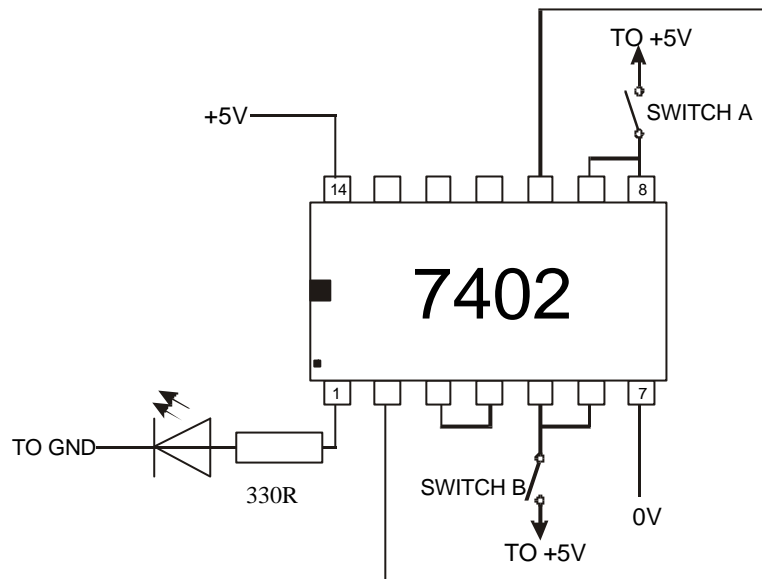

AE.H.LO3. fig 58

Construct a Truth table for this circuit and determine the single gate that could replace this NOR equivalent circuit.

2. Construct the following circuit using a 7400 IC, two push switches as inputs and a logic probe on pin 8 to indicate the state of the output. (Power supply and switch connections have been omitted for clarity.)

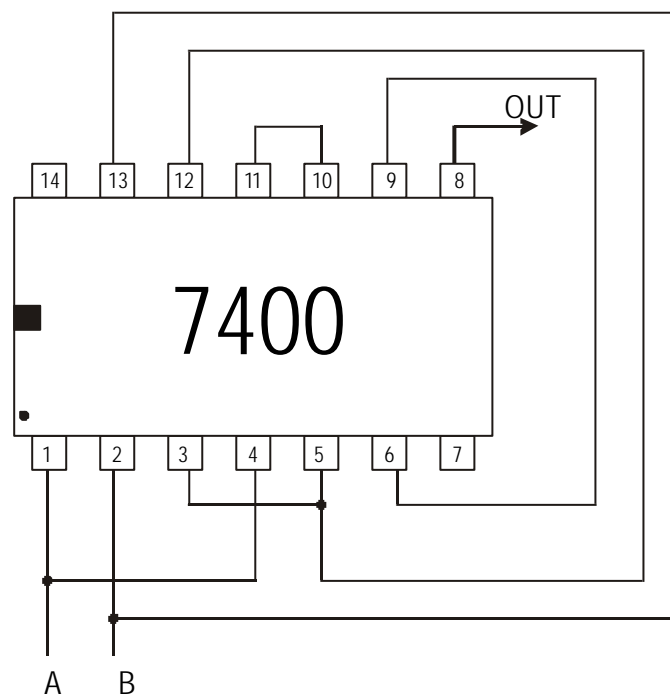

AE.H.LO3. fig 59

Construct a Truth table for this circuit and determine the single gate that could replace this NAND equivalent circuit.

3. The guard on a machine must be in place before the machine will operate. A push switch is ON when the guard is in place. If the machine is switched ON when the guard is not in place, it will not operate and an alarm will sound.

Truth table

Inputs		Outputs	
guard	machine	alarm	machine
0	0	0	0
0	1	1	0
1	0	0	0
1	1	0	1

- a) Write Boolean expressions for the two HIGH output states.
 - b) Draw a logic diagram for the circuit.
 - c) Use a circuit simulation package (e.g. 'Croc clips') to check that your circuit is correct.
 - d) Draw a wiring diagram for the circuit using a 7404 and a 7408 IC.
 - e) Construct the circuit using a red led for the alarm and a green led to show that the machine is operating.
4. A latch circuit is used when we wish the output signal to remain HIGH even when the actuating input signal returns to its original value, e.g. when a burglar alarm is set off, it should keep going until it is reset (either manually or by a timer) even if the burglar is no longer there.
A simple latch can be made using a single OR gate with the output signal fed-back to one of the inputs.

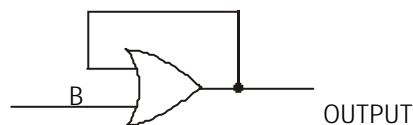

AE.H.LO3. fig 60

Here if input A goes HIGH, the output goes HIGH, this is fed-back to input B so that even if A goes LOW, the output will always remain HIGH. This latch however has one fairly major drawback. (If you don't know what it is, try building the circuit on a simulator with a switch input and an indicator output.)

A better latch is shown below, here the output signal can be reset by making switch B HIGH.

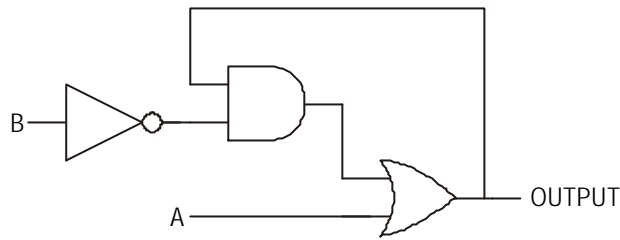

AE.H.LO3. fig 61

(You can again test this on the ‘Croc clips’ simulator)

Although this circuit works OK, it uses 3 different gates (and hence 3 different IC’s)

Draw a NAND equivalent circuit for the gates in figure 61.

When you cancel the double inversions, you should be left with 4 NAND gates.

Although this circuit uses one more gate, all these gates are the same and are on one IC (therefore cheaper and easier to manufacture)

Draw a wiring diagram for your NAND circuit and construct the circuit using push switches for the inputs and an led for the output.

5. a) Draw a schematic diagram showing how two 2-input AND gates may be connected to produce a 3-input AND gate.
- b) A 7408 is a quad 2-input AND gate IC.

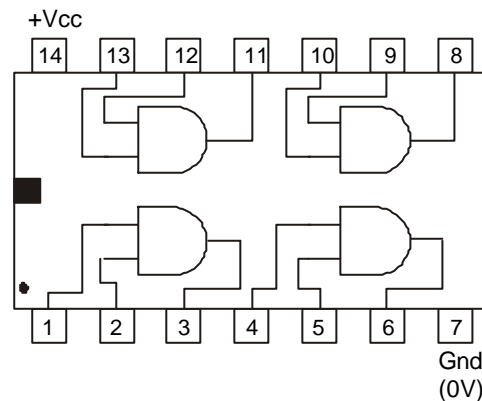

Redraw this diagram and show, by marking in the connections, how this circuit could be used to produce two 3-input AND gates. Clearly mark each of the inputs and outputs.

- c) A part of the control circuit for a motor in an automatic washing machine has to ensure that the motor will only switch on when:
 - i) the water level in the machine is above a certain level and
 - ii) the water temperature is either below 25°C or above 60°C.

Construct a truth table and draw a diagram showing how logic gates may be used to provide this control assuming that logic level 1 is indicated by:
 high water level
 water temperature $<25^{\circ}\text{C}$
 water temperature $>60^{\circ}\text{C}$
 motor switch on

d) The output from the logic gates mentioned in (c) cannot cope directly with the power required to operate the motor. Draw a diagram showing a typical circuit that would enable the output of the gates to switch the motor on.

6. The diagram below shows a quadruple 2-input NAND gate IC.

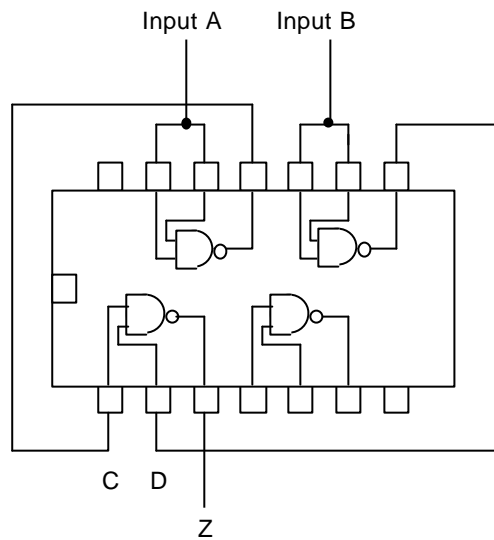

Construct the truth table for the circuit shown and hence state the single gate that could perform the same function. The truth table should contain columns A, B, C, D and Z.

SEB & SQA PAST PAPER EXAM QUESTIONS

1997, Paper 1, question 1

The executive model in a new range of cars has a number of additional features.

- (a) One such feature is a heater in the driver's seat which switches on automatically when the ignition key (K) is inserted in the ignition, a pressure sensor (P) senses that someone is sitting in the seat and a temperature sensor (T) indicates that it is cold (*the temperature sensor gives a logic 1 when hot*). Alternatively, the heater can be switched on manually by a switch (S).
Draw a logic diagram which will control the heater as described above (You may use any logic gates)
- (b) Another feature is a courtesy light which comes on when the drivers door is opened. After a short time delay the light switched off.
Show how NAND gate could be connected together to control this action of the courtesy light. Assume that the door sensor (D) goes to logic 1 when the door is opened and the time delay unit (U) sends a logic 1 pulse after a specific time.

1994, Paper 1, question 9

- (a) Show how you could configure a 3-input OR gate using each of the following TTL Ics
- 2-input OR gates;
 - 4-input OR gates;
 - 3-input NAND gates.
- N.B. A separate diagram for each solution.
- (b) A logic diagram is shown in figure Q1

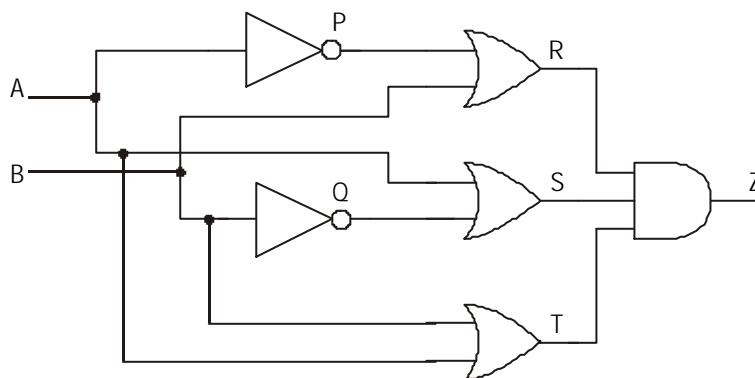

AE.LO3. fig Q1

- Draw up a truth table for this logic system and hence write a logic statement (Boolean) for the output Z, in terms of the two inputs A and B.
- Draw a simplified logic diagram, using only NAND gates, which will operate in exactly the same way as figure Q1.

1993, Paper 1, question 11

(part)

Toxic waste from a chemical plant flows to a storage tank for later reprocessing as shown in figure Q2. Flow from the waste to the tank is controlled by a main inlet valve. Should the level of waste in the tank become too high, as detected by a level sensor at the top of the tank, the main inlet valve should close and a warning alarm should sound. The waste should then be directed by means of a relief valve to a relief tank.

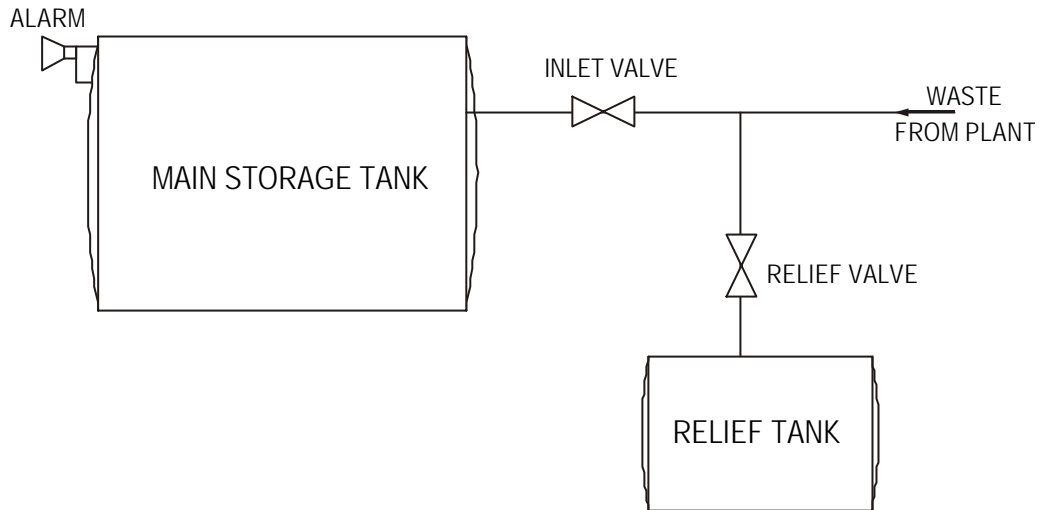

AE.LO3. fig Q2

- (a) **Draw** a truth table for the system. Take the valves, level sensor and switch to be at logic 0 when open and logic 1 when closed.
- (b) **Develop** an expression (Boolean) for each of the outputs from the system.
- (c) **Draw** a logic diagram for the control system.

1995, Paper 1, question 8

An industrial stamping machine (M) is wired with a logic control system for its safe control. The machine has a safety guard which closes a limit switch (L) when it is in place. The machine must never operate unless the guard is in position.

The machine motor bearings must be lubricated with oil. An oil pressure switch (P) is used to indicate that there is sufficient pressure to do this.

The machine can only be started if the guard is in position, the oil pressure is sufficient, and either a foot pedal (F) or a push button (B) is pressed.

Assume the following logic conditions for the various inputs and outputs:

Machine in operation ($M = 1$); Limit switch pressed ($L = 1$);

High oil pressure ($P = 1$); Foot pedal pressed ($F = 1$); Push button pressed ($B = 1$).

- (a) Draw up a truth table to show how the stamping machine (M) is controlled in terms of the inputs L, P, F and B.
- (b) Write a logic statement (Boolean) for M in terms of L, P, F and B.
- (c) Draw a logic diagram of the control system used to operate the stamping machine, if the system is to be constructed:
 - (i) using AND and OR logic gates;
 - (ii) entirely from NAND gates.

1997, Paper 2, question 4

(part (a) only)

Figure Q3 shows a motorised control valve which is used in a domestic central heating system. A cam and micro switch arrangement is used to sense the position of the motorised control valve. A pump is used to circulate the hot water from the boiler.

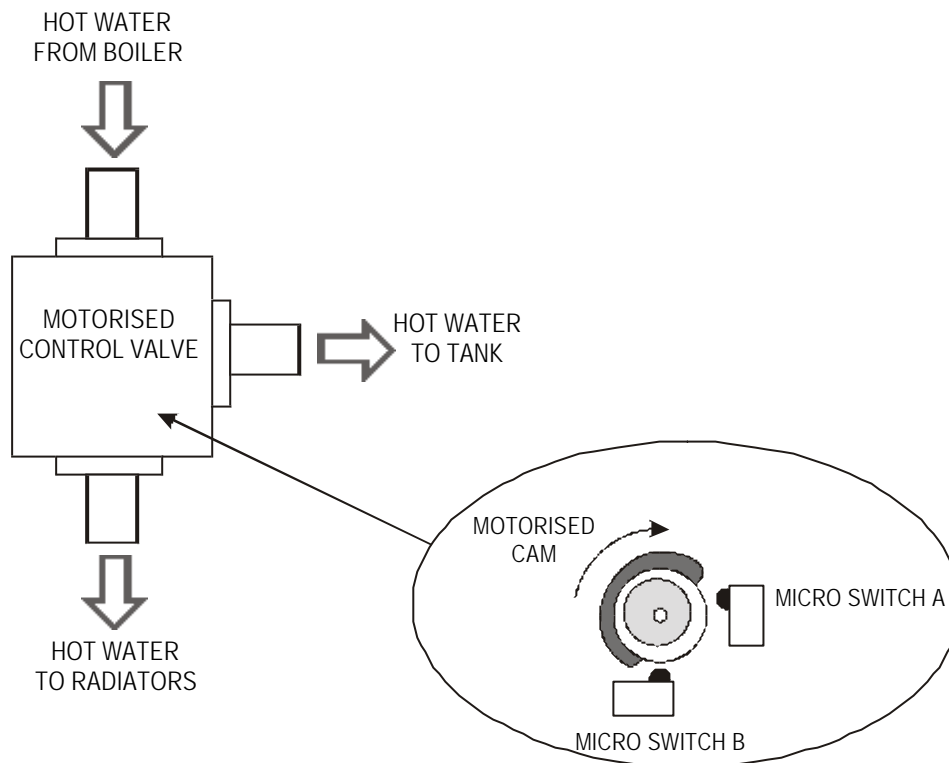

AE.LO3. fig Q3

The valve has four positions.

Valve position	Micro switch state
Closed	A = 1 B = 0
Hot water to tank only	A = 1 B = 0
Hot water to tank and radiators	A = 1 B = 1
Hot water to radiators only	A = 0 B = 1

The valve motor and the hot water pump are activated by signals from either the room thermostat or the hot water thermostat. If a low signal is received from either thermostat, the motorised valve should move to the corresponding position. The pump should not switch on unless the motorised control valve is in the appropriate position.

- (i) An incomplete truth table for the heating control system is shown on **Worksheet 1997 Q4**. Complete the truth table on the **Worksheet**.
- (ii) Write a Boolean expression to describe the logic control of the pump.
- (iii) Using AND, OR and NOT logic gates, draw the logic control system for the pump.

1998, Paper 1, question 4

A test engineer suspects that one of the TTL logic ICs she is using may be faulty and decides to investigate the problem. A pin-out diagram of the circuit is shown in figure Q4 and an incomplete performance checklist table in Table Q4. The engineer tests the circuit and she finds that the IC is working properly.

Study the circuit, with the switches A and B **positioned as shown**, and then copy and complete the checklist table by entering ! or 0 in the *Logic State* column for each of the fourteen pins.

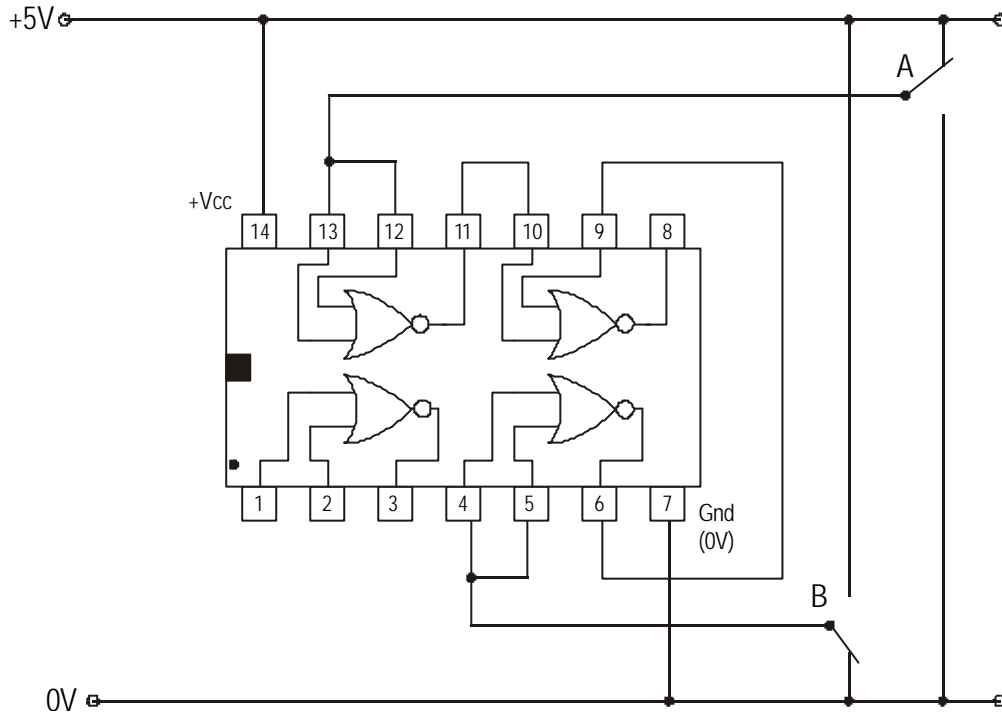

AE.LO3. fig Q4

Pin Number	Logic State
1	
2	
3	
4	
5	
6	
7	
8	
9	
10	
11	
12	
13	
14	

Table Q4

1998, Paper 1, question 11

(part)

In the interests of safety, the heating kiln in a ceramics factory is operated by a combination of switches A, B and C. The heater is switched on and off by a relay, which is controlled by the circuit shown in figure Q5. The logic gates being used are CMOS and are operated from a 12 V supply. The relay is rated at 12 V, 50 mA.

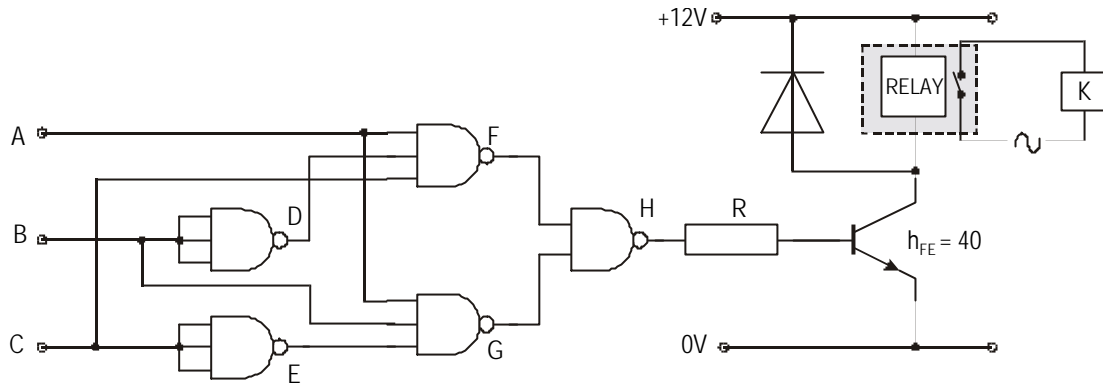

AE.LO3. fig Q5

- (a) (i) Draw up a truth table to show the control of the kiln heater K in terms of the three inputs A, B and C.
- (ii) Write a Boolean statement for the kiln heater K in terms of the inputs A, B and C.

- (b) The relay fully energises when V_{be} is 0.7 V. The transistor has a current gain of 40. For this condition, determine:
- (i) the base current required in the transistor;
 - (ii) the value of the base resistor R requires to operate the relay as described above.

WORKSHEET 1997 Q4

Inputs				Outputs	
Thermostats		Microswitches		Heating Control	
Room (R)	Hot Water Tank (H)	A	B	Valve Motor (V)	Pump (P)
0	0	0	0		
0	0	0	1		
0	0	1	0		
0	0	1	1		
0	1	0	0		
0	1	0	1		
0	1	1	0		
0	1	1	1		
1	0	0	0		
1	0	0	1		
1	0	1	0		
1	0	1	1		
1	1	0	0		
1	1	0	1		
1	1	1	0		
1	1	1	1		

TRUTH TABLES WORKSHEET

Use the circuit simulator to set up and test the following gates.

Use push switches as inputs and an indicator to show the state of the output.

1. NOT gate

INPUT	OUTPUT
0	
1	

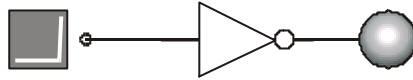

2. AND gate

INPUT	OUTPUT	
A	B	
0	0	
0	1	
1	0	
1	1	

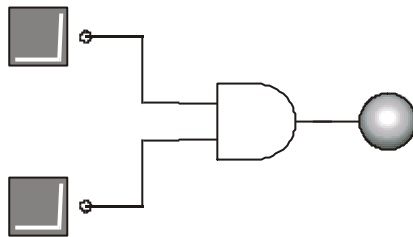

3. OR gate

INPUT	OUTPUT	
A	B	
0	0	
0	1	
1	0	
1	1	

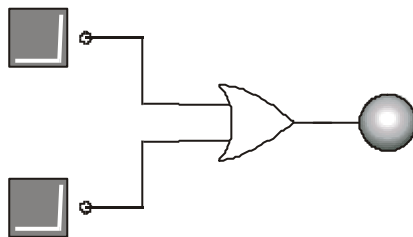

4. NAND gate

INPUT		OUTPUT
A	B	
0	0	
0	1	
1	0	
1	1	

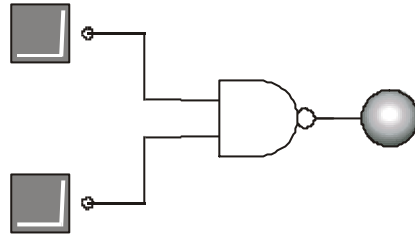

5. NOR gate

INPUT		OUTPUT
A	B	
0	0	
0	1	
1	0	
1	1	

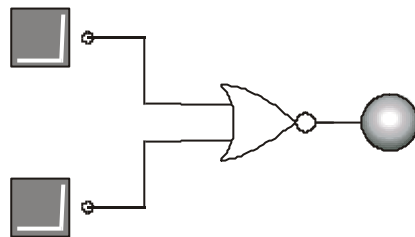

6. XOR gate

INPUT		OUTPUT
A	B	
0	0	
0	1	
1	0	
1	1	

