

Square - 50 side



Hexagon - 70 A/F



Hexagon - 70 A/C  
Hexagon - 35 side

Octagon - 70 A/F

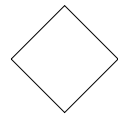

Square - 50 side



Hexagon - 70 A/F



Hexagon - 70 A/C  
Hexagon - 35 side

Octagon - 70 A/F

Name:

Class:

Date:

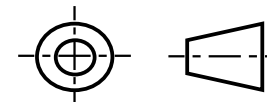

Question No:

**Geometric Drawings — Introduction**

# Geometric Drawing — 1

Draw, in the suggested positions, the following views of the square prism:

- a) End
- b) Surface Development
- c) Add a 45° cutting plane to the Front Elevation and complete the other two views.

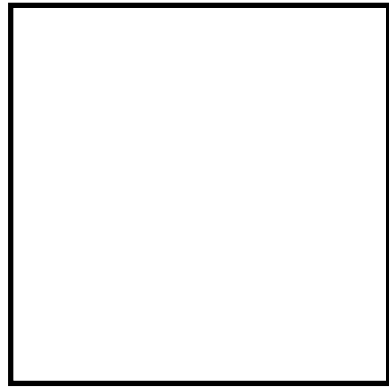

PLAN

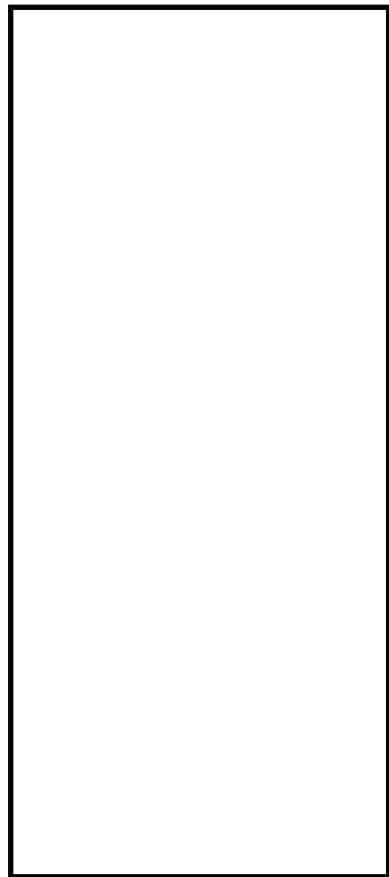

FRONT ELEVATION



SECTIONAL END

SURFACE DEVELOPMENT

Name:

Class:

Date:

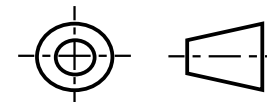

Question No:

**Geometric Drawings — 1**

## Geometric Drawing — 2

Draw, in the suggested positions, the following views of the rectangular prism:

- a) End
- b) Surface Development
- c) Add a 45° cutting plane to the Front Elevation and complete the other two views.



PLAN

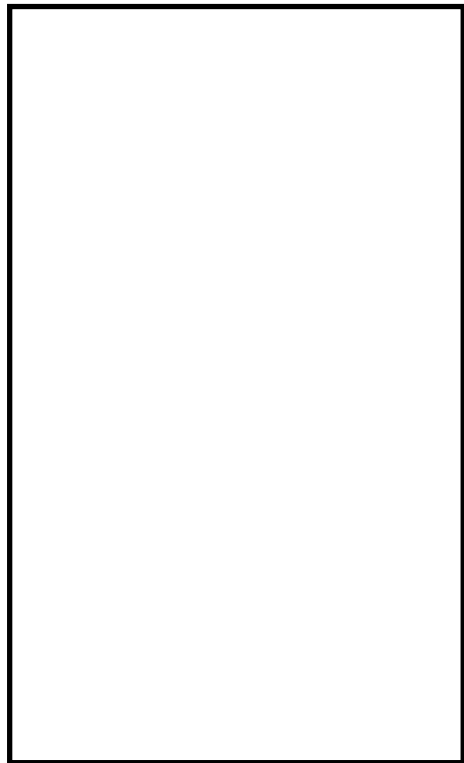

FRONT ELEVATION



SECTIONAL END

SURFACE DEVELOPMENT

Name:

Class:

Date:

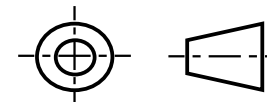

Question No:

**Geometric Drawings — 2**

# Geometric Drawing — 3

Draw, in the suggested positions, the following views of the hexagonal prism:

- a) End Elevation
- b) Surface Development

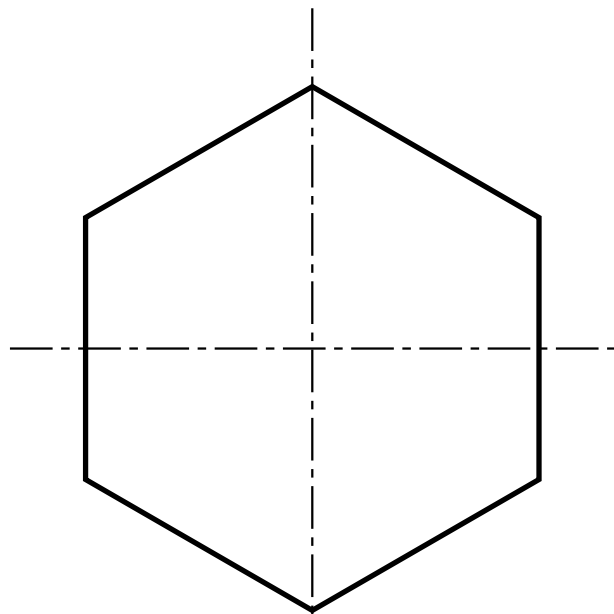

PLAN

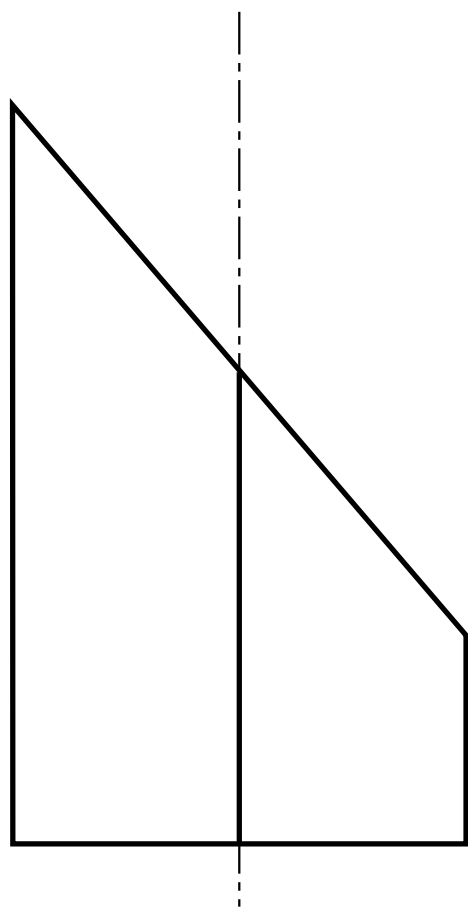

FRONT ELEVATION



END ELEVATION

SURFACE DEVELOPMENT

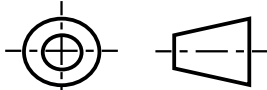
Name:	Class:	Date:		Question No: <b>Geometric Drawings — 3</b>
-------	--------	-------	---	--

# Geometric Drawing — 4

Draw, in the suggested positions, the following views of the sectioned hexagonal prism:

- a) Sectional End Elevation
- b) Surface Development

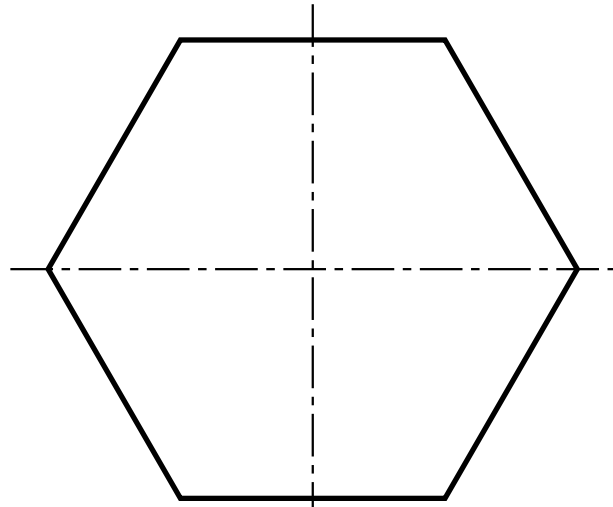

PLAN

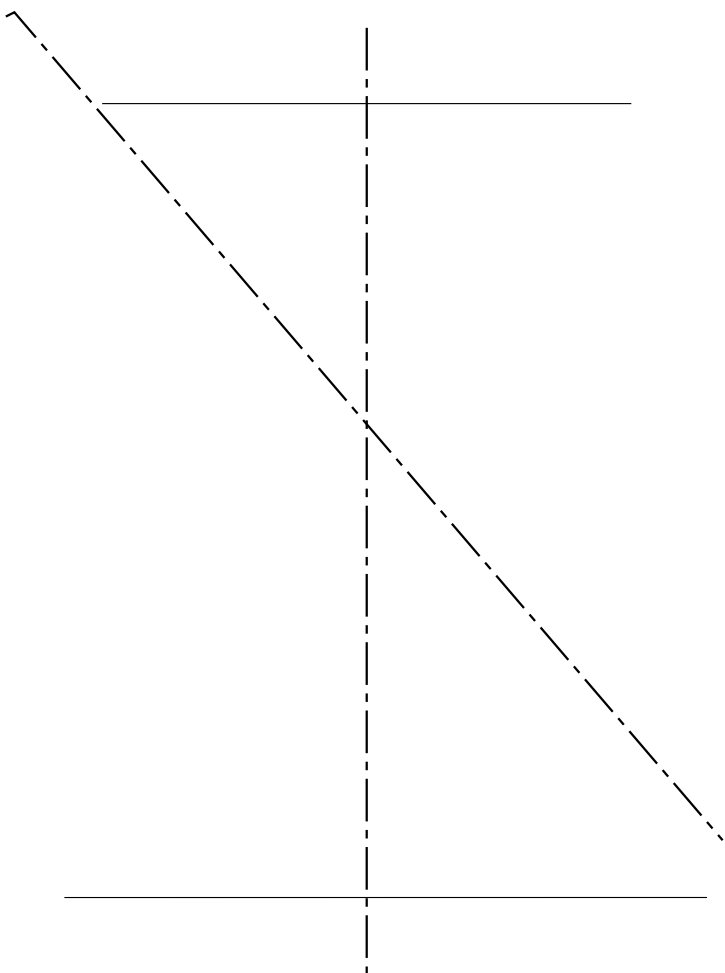

FRONT ELEVATION

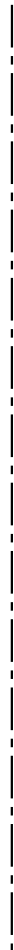

SECTIONAL END ELEVATION

SURFACE DEVELOPMENT

Name:	Class:	Date:		Question No: <b>Geometric Drawings — 4</b>
-------	--------	-------	--	--

## Geometric Drawing — 5

Draw, in the suggested positions, the following views of the octagonal prism:

- a) End Elevation
- b) Surface Development

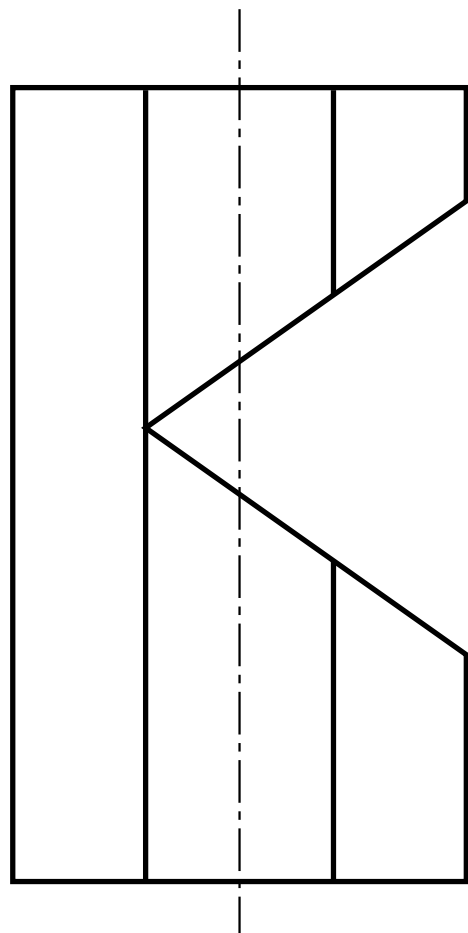
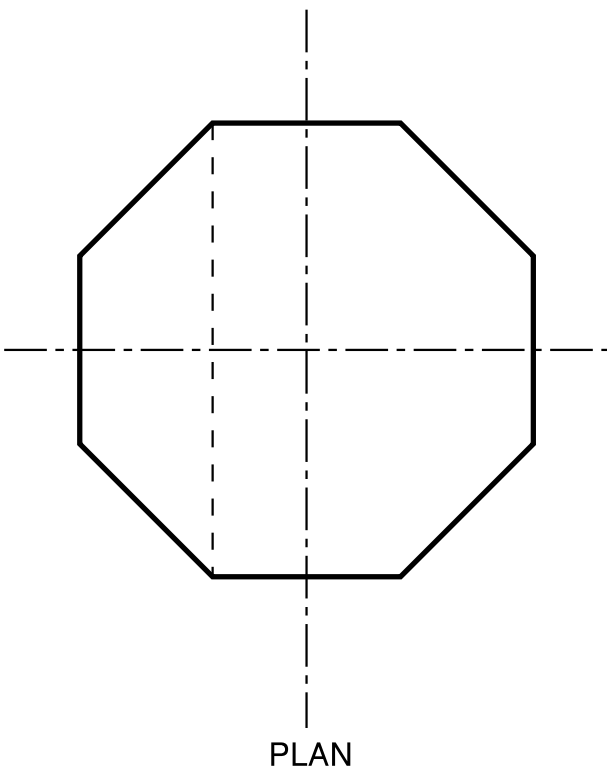

SURFACE DEVELOPMENT

Name:

Class:

Date:

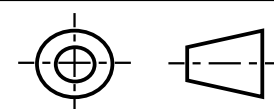

Question No:

**Geometric Drawings — 5**

# Geometric Drawing — 6

Draw, in the suggested positions, the following views of the given sectioned prism:

- a) Completed Sectional Plan
- b) Sectional End Elevation
- c) Surface Development

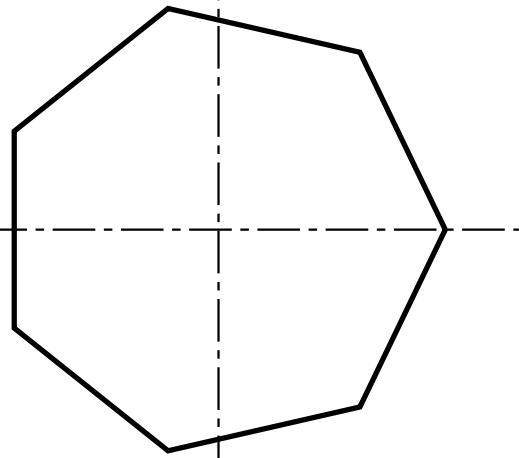

PLAN

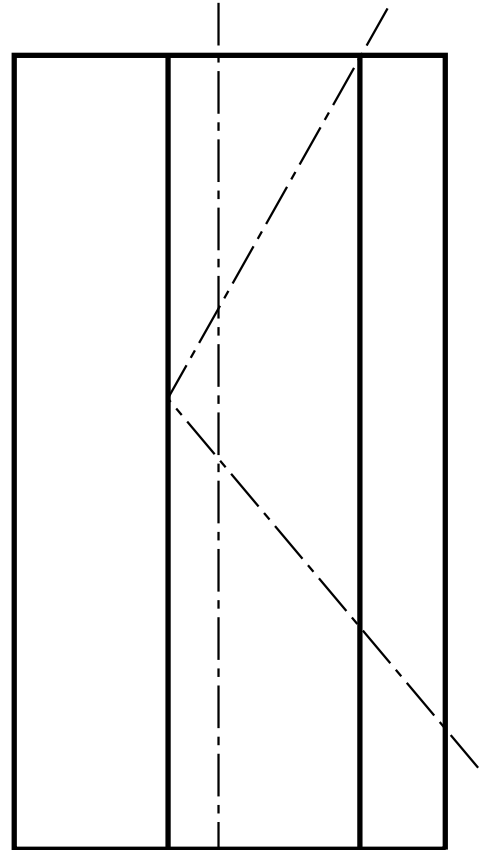

FRONT ELEVATION



SECTIONAL END ELEVATION

SURFACE DEVELOPMENT

Name:

Class:

Date:

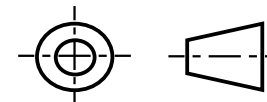

Question No:

# Geometric Drawing — 7

Draw, in the suggested positions, the following views of the sectioned cylinder:

- a) Sectional End
- b) Surface Development

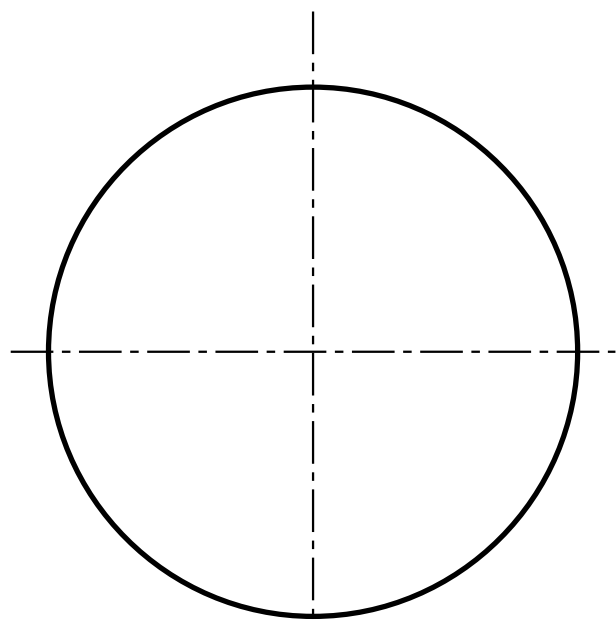

PLAN

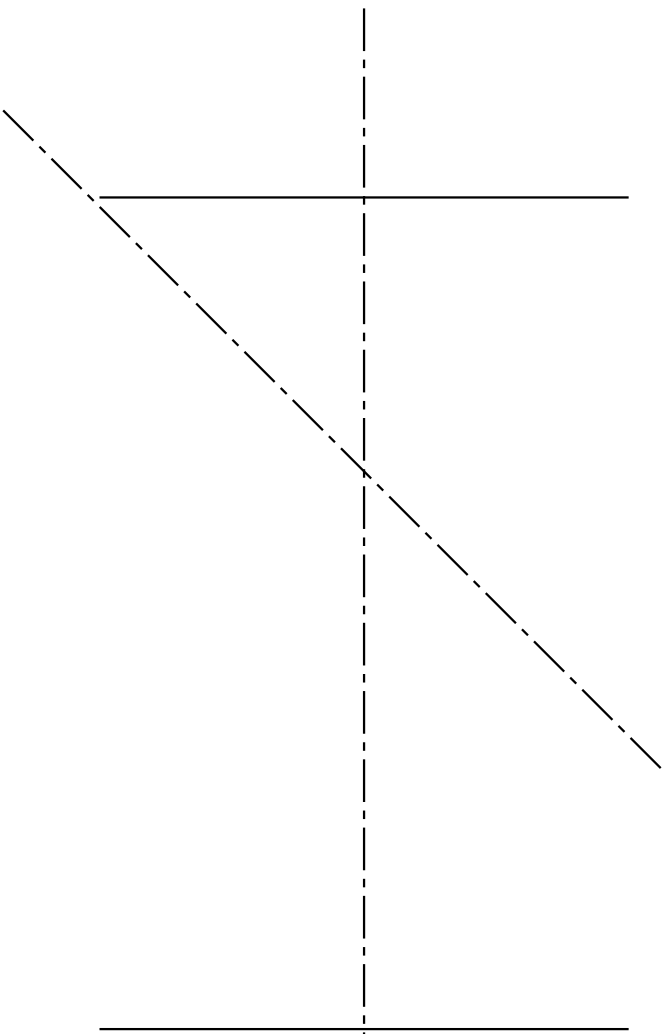

FRONT ELEVATION



SECTIONAL END ELEVATION

SURFACE DEVELOPMENT

Name:

Class:

Date:

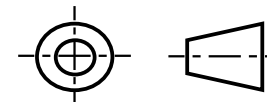

Question No:



# Geometric Drawing — 8

Draw, in the suggested positions, the following views of the sectioned cylinder:

- a) Sectional End
- b) Surface Development

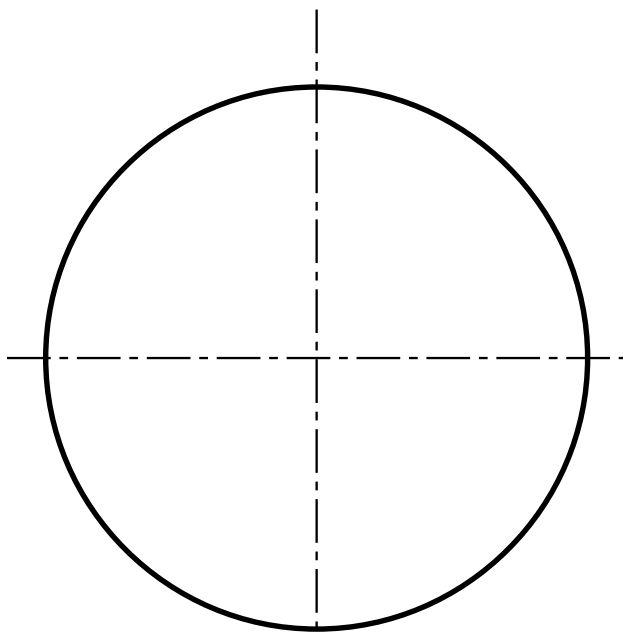

PLAN

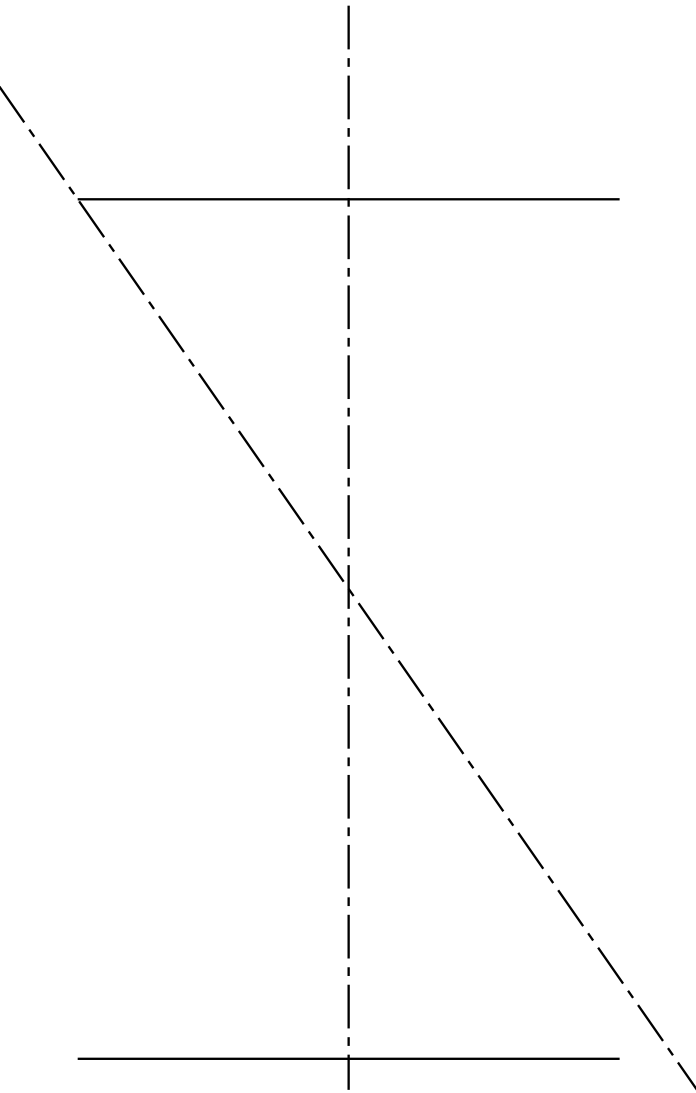

FRONT ELEVATION



SECTIONAL END ELEVATION

SURFACE DEVELOPMENT

Name:

Class:

Date:

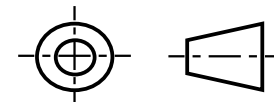

Question No:

# Geometric Drawing — 9

Draw, in the suggested positions, the following views of the sectioned cylinder:

- a) Sectional End
- b) Completed Plan
- c) Surface Development

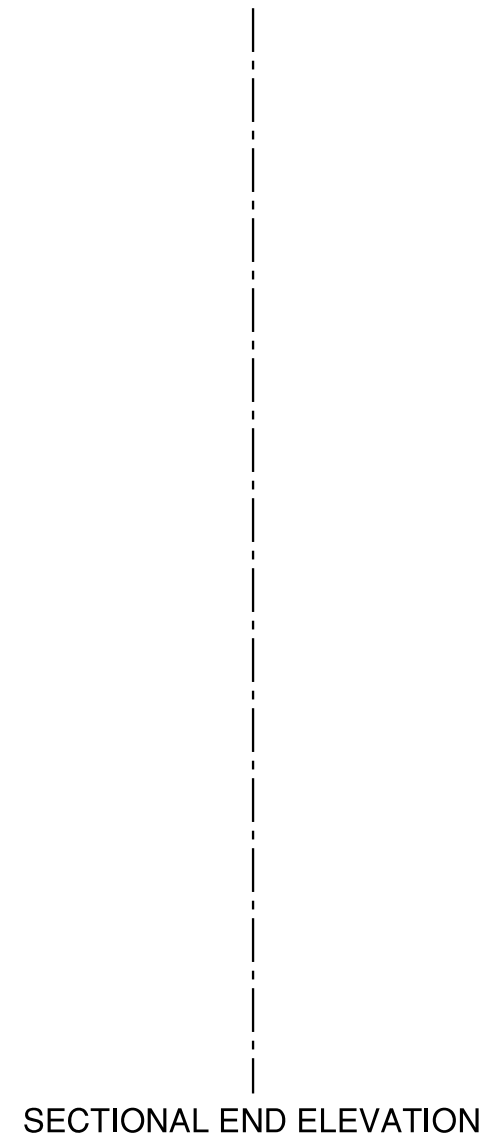
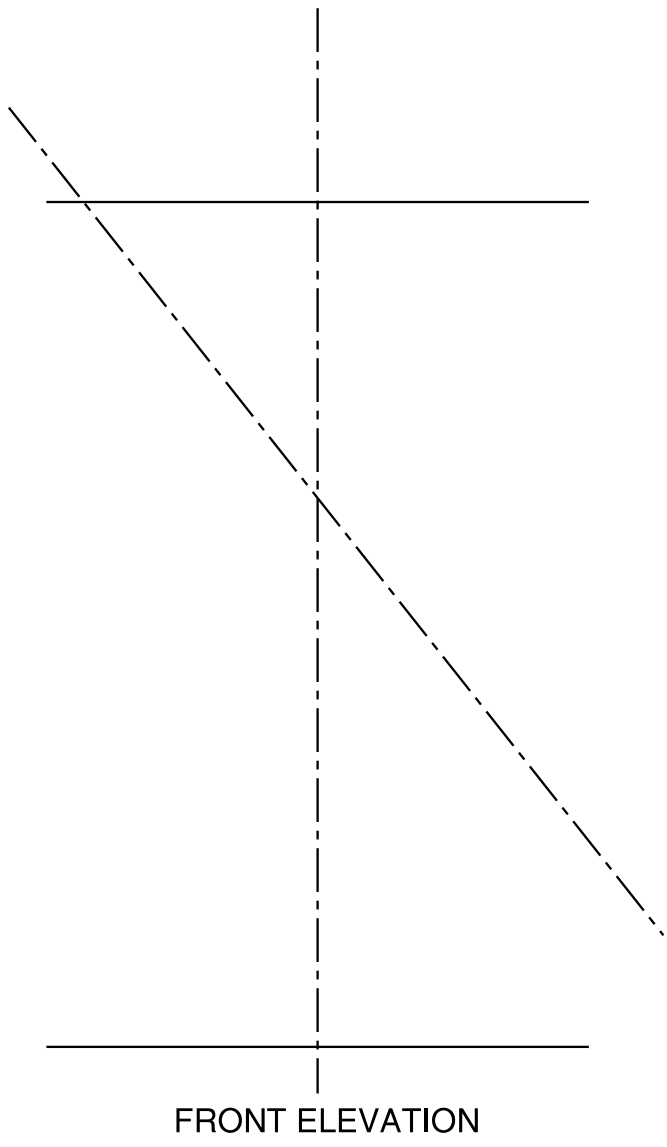
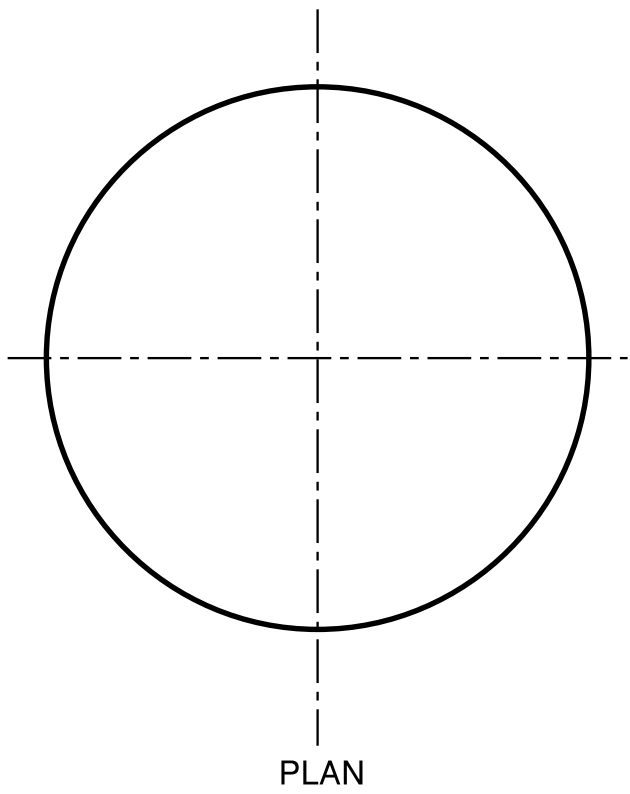

SURFACE DEVELOPMENT

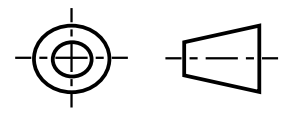
Name:	Class:	Date:		Question No:	<b>Geometric Drawings — 9</b>
-------	--------	-------	---	--------------	-------------------------------

# Geometric Drawing — 10

Draw, in the suggested positions, the following views of the sectioned solid cylinder:

- a) Sectional End
- b) Completed Plan
- c) Surface Development

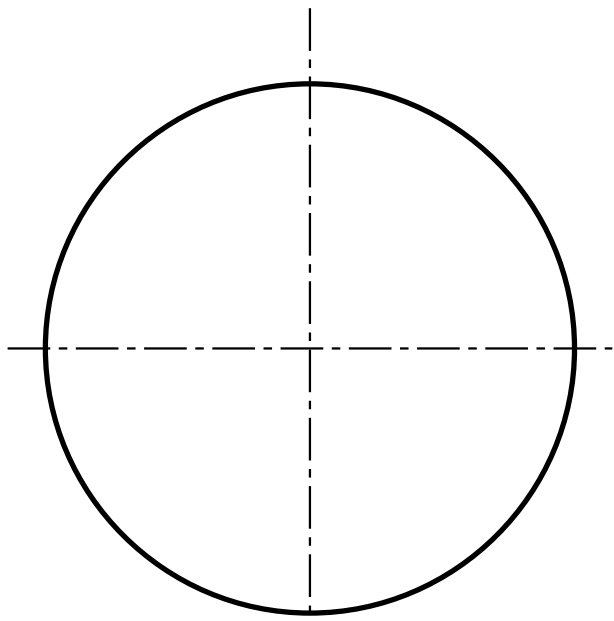

PLAN

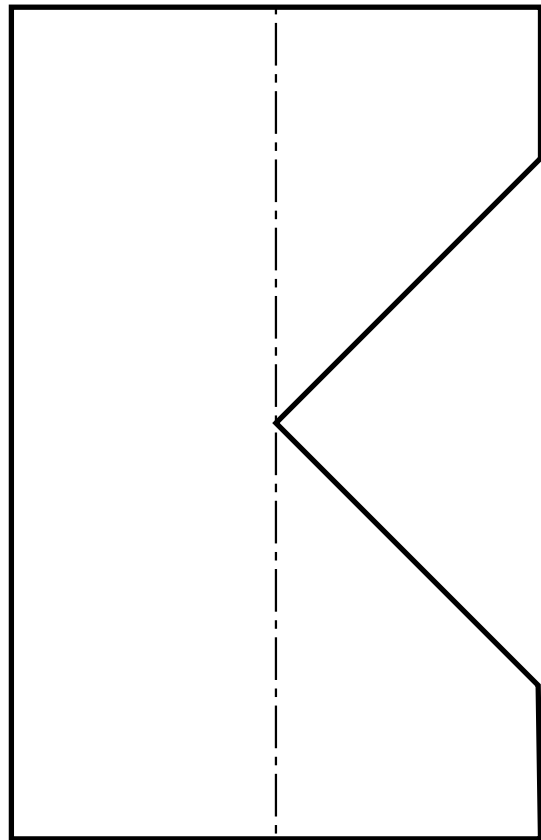

FRONT ELEVATION



SECTIONAL END ELEVATION

SURFACE DEVELOPMENT

Name:

Class:

Date:

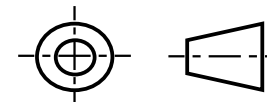

Question No:

# Geometric Drawing — 11

Draw, in the suggested positions, the following views of the sectioned solid cylinder:

- a) Sectional End
- b) Completed Plan
- c) Surface Development

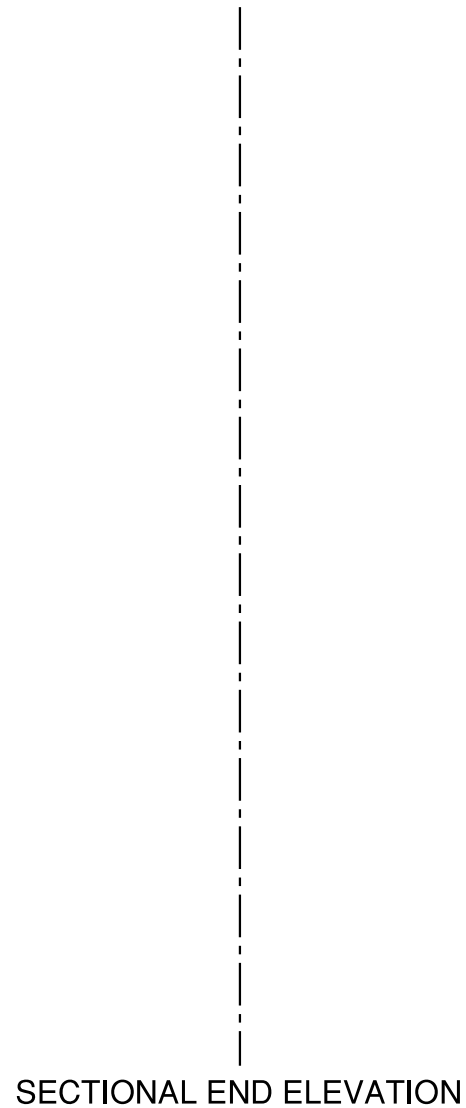
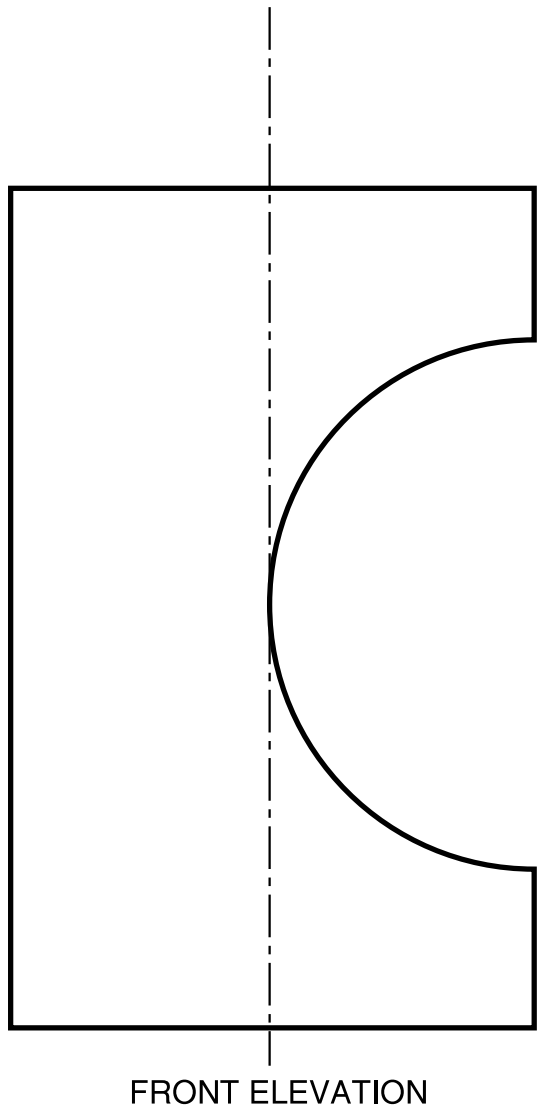
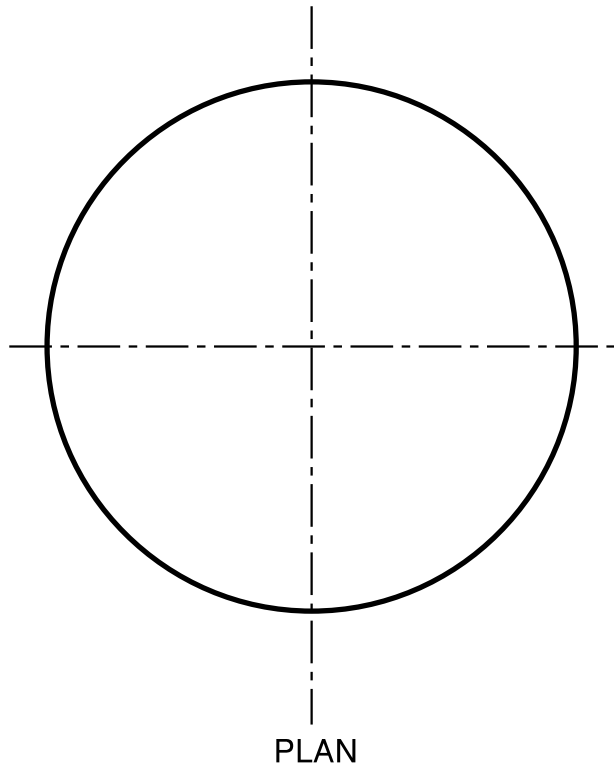

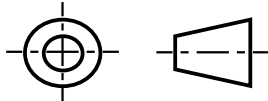
Name:	Class:	Date:		Question No:	<b>Geometric Drawings — 11</b>
-------	--------	-------	---	--------------	--------------------------------

## Geometric Drawing — 12

Draw, in the suggested positions, the following views of the sectioned, half-square / half-circular, prism:

- a) Sectional End
- b) Surface Development

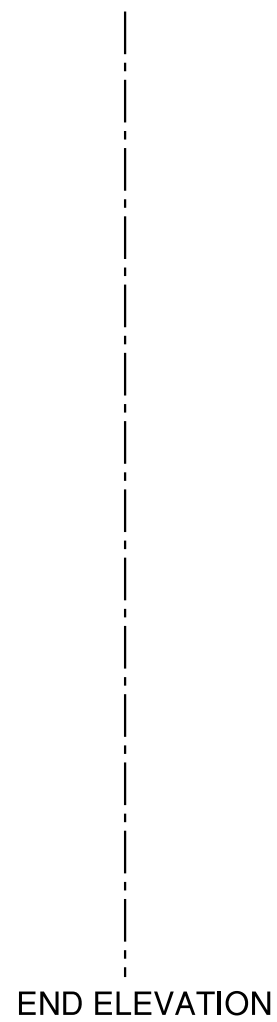
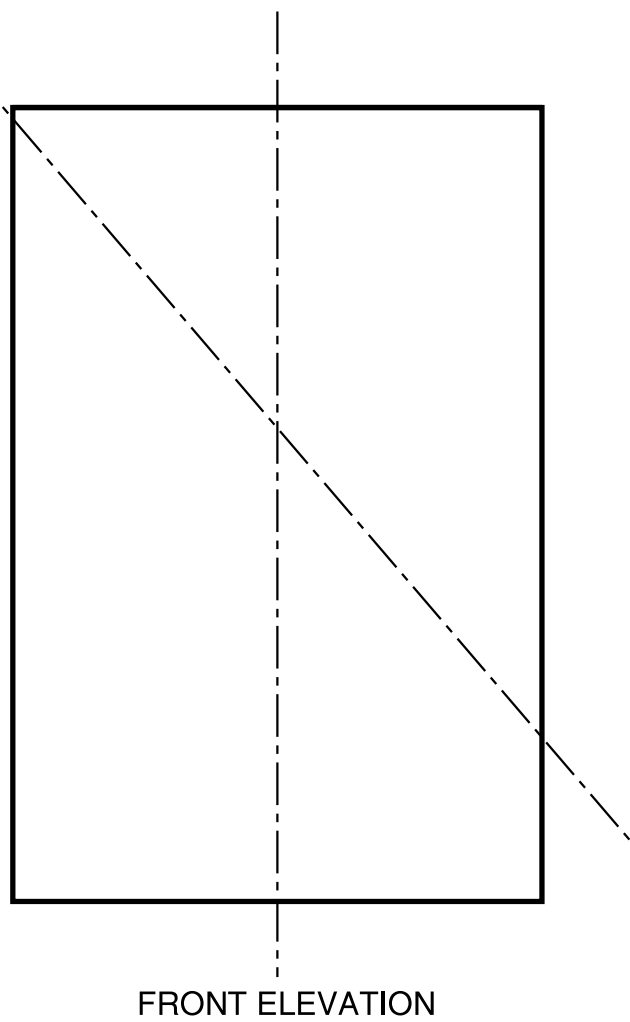
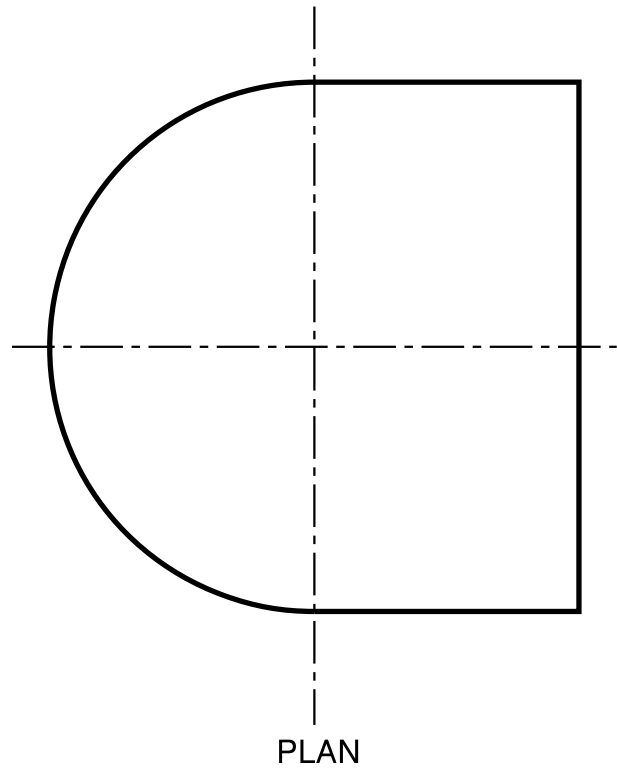

SURFACE DEVELOPMENT

Name:

Class:

Date:

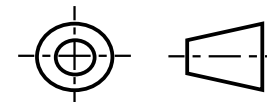

Question No:

**Geometric Drawings — 12**

# Geometric Drawing — 13

Draw, in the suggested positions, the following views of the square pyramid:

- a) End
- b) Surface Development
- c) Add a 45° cutting plane to the Front Elevation, half way up the centre line and complete the other two views.

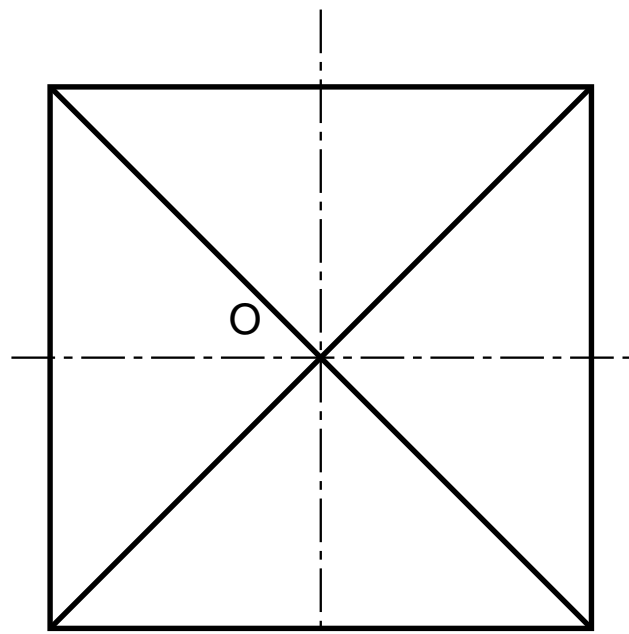

PLAN

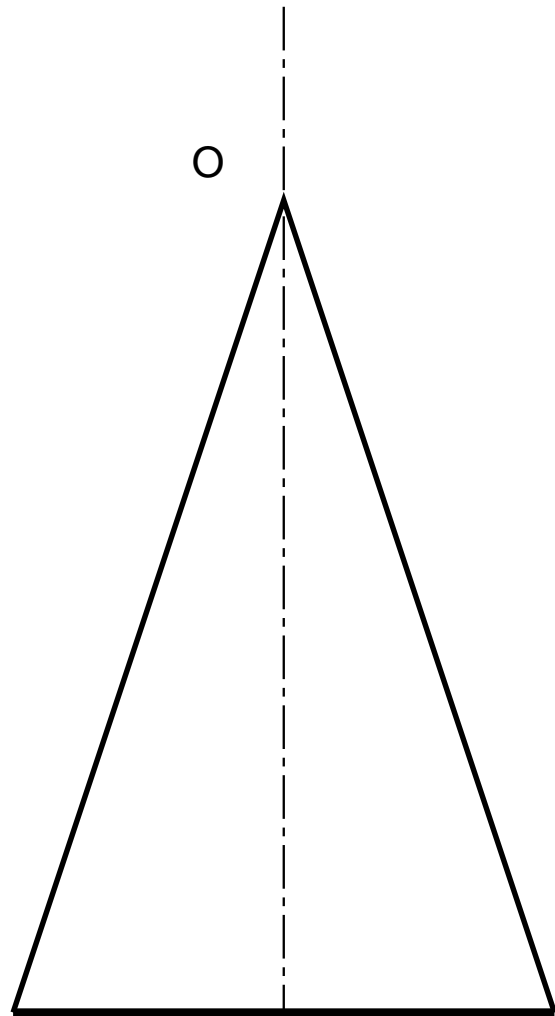

FRONT ELEVATION



END ELEVATION



SURFACE DEVELOPMENT

Name:	Class:	Date:		Question No:	<b>Geometric Drawings — 13</b>
-------	--------	-------	--	--------------	--------------------------------

# Geometric Drawing — 14

Draw, in the suggested positions, the following views of the sectioned rectangular pyramid:

- a) Completion of the Sectional Plan
- b) Sectional End Elevation
- c) Surface Development

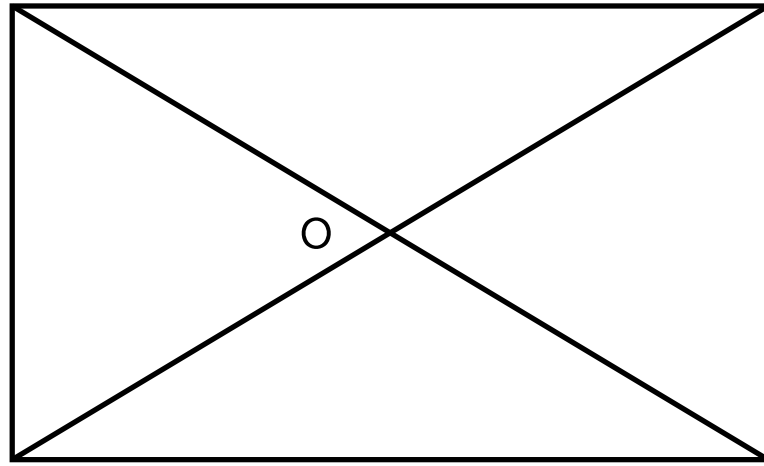

SECTIONAL PLAN

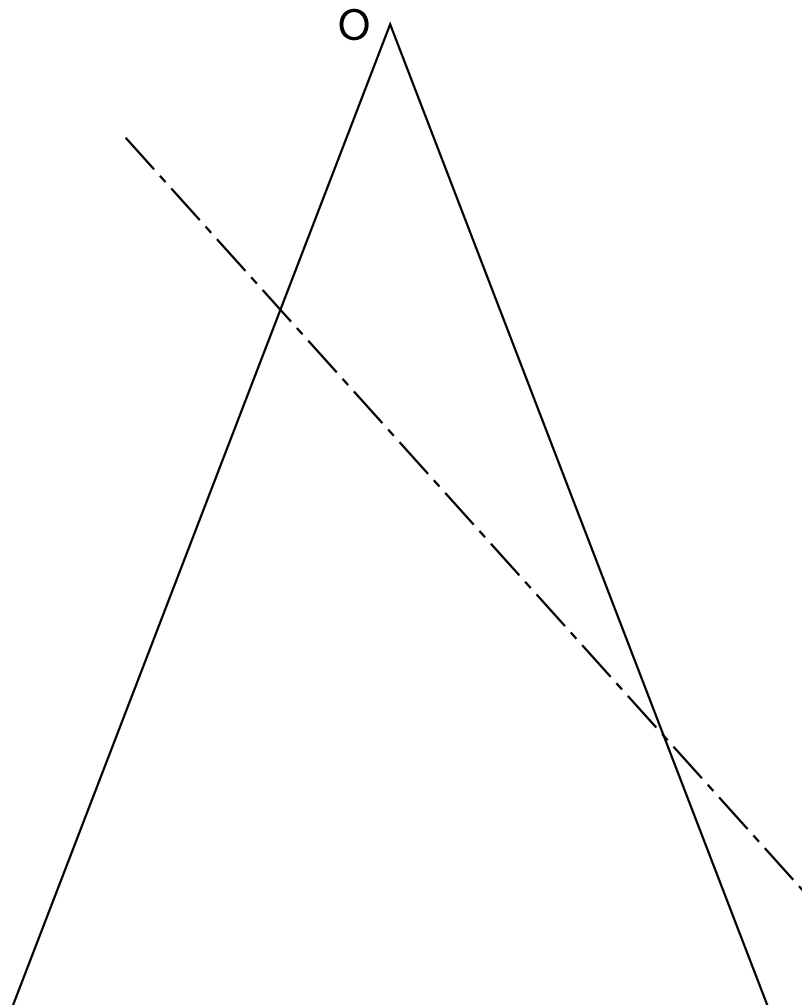
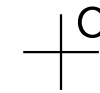

FRONT ELEVATION



SECTIONAL END ELEVATION

SURFACE DEVELOPMENT

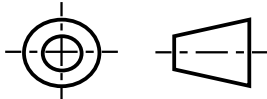
Name:	Class:	Date:		Question No: <b>Geometric Drawings — 14</b>
-------	--------	-------	---	---

# Geometric Drawing — 15

Draw, in the suggested positions, the following views of the sectioned hexagonal pyramid:

- a) Completed Sectional Plan
- b) Sectional End
- c) Surface Development

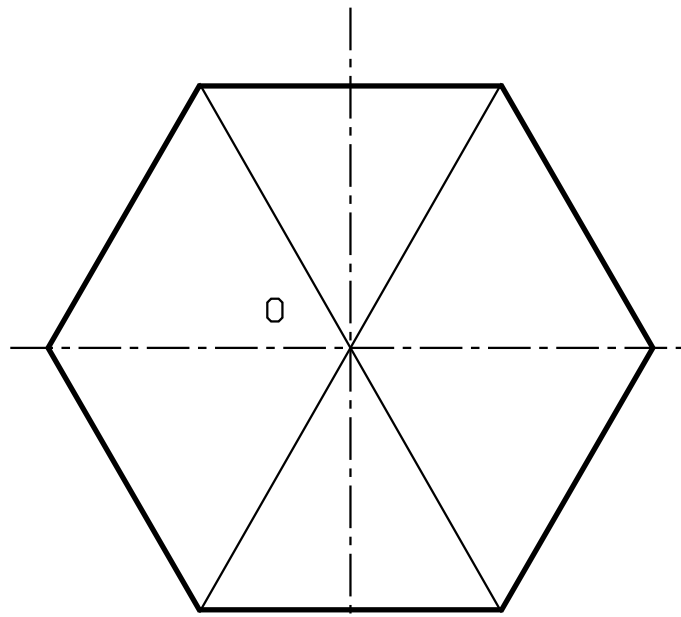

SECTIONAL PLAN

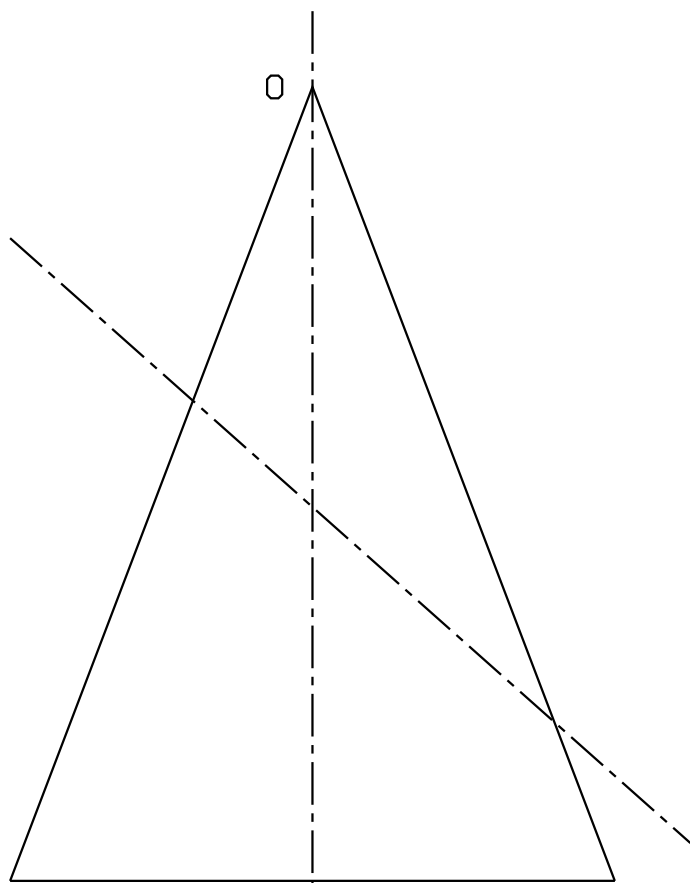

FRONT ELEVATION

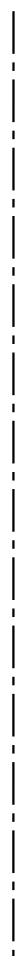

SECTIONAL END ELEVATION

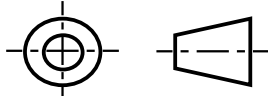

SURFACE DEVELOPMENT

Name:	Class:	Date:		Question No:	<b>Geometric Drawings — 15</b>
-------	--------	-------	---	--------------	--------------------------------



# Geometric Drawing — 16

Draw, in the suggested positions, the following views of the sectioned hexagonal pyramid:

- a) Completed Sectional Plan
- b) Sectional End
- c) Surface Development

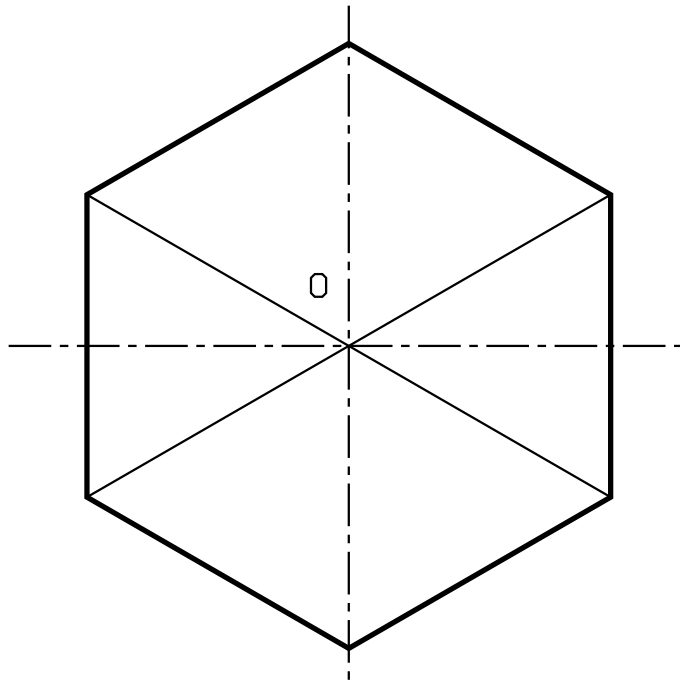

SECTIONAL PLAN

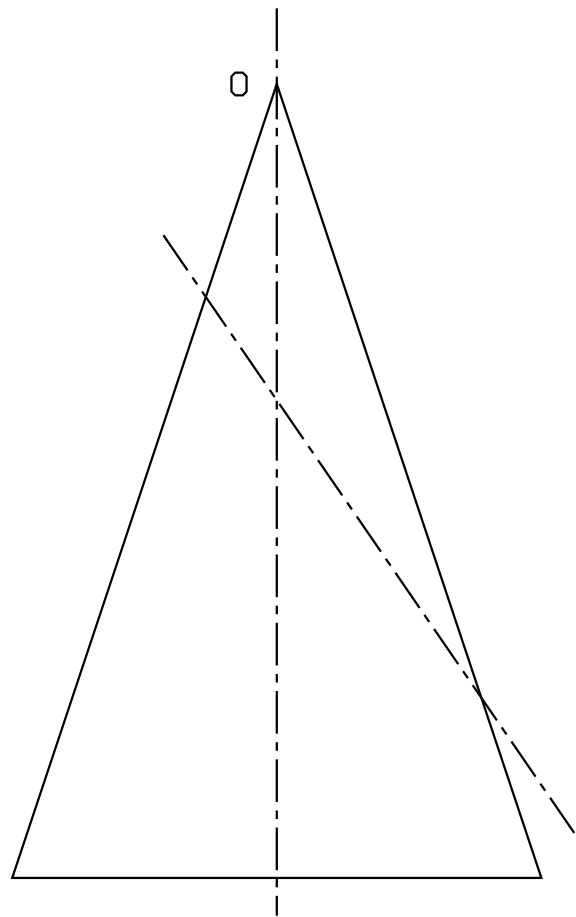
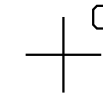

FRONT ELEVATION



SECTIONAL END ELEVATION

SURFACE DEVELOPMENT

Name:	Class:	Date:		Question No:	<b>Geometric Drawings — 16</b>
-------	--------	-------	--	--------------	--------------------------------

# Geometric Drawing — 17

Draw, in the suggested positions, the following views of the sectioned octagonal pyramid:

- a) Sectional Plan
- b) Sectional End
- c) Surface Development

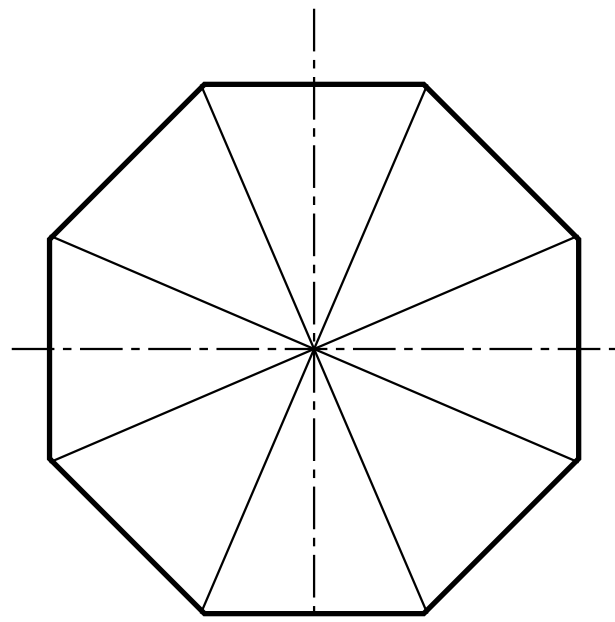

PLAN

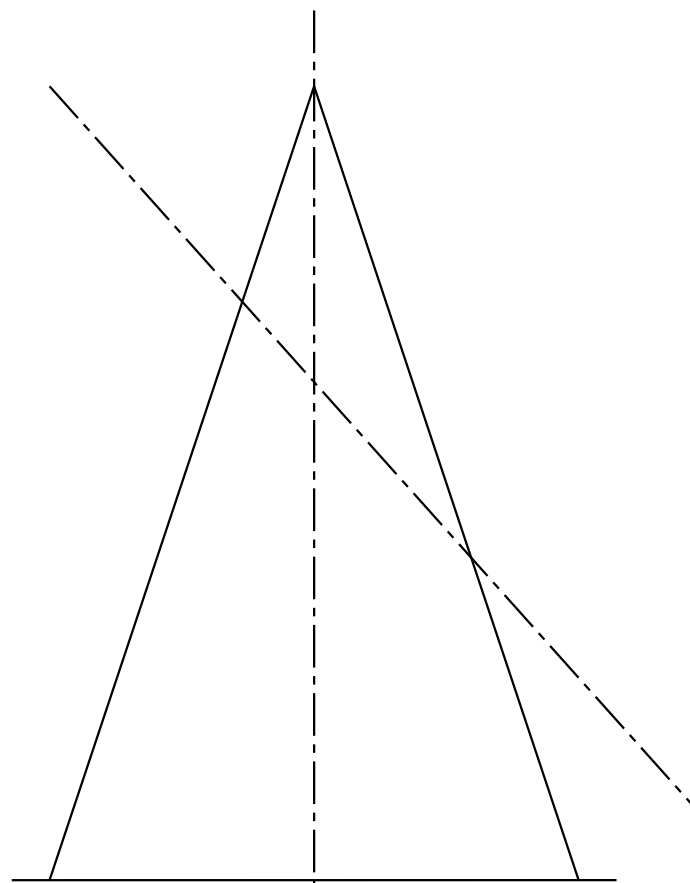

FRONT ELEVATION



SECTIONAL END



SURFACE DEVELOPMENT

Name:

Class:

Date:

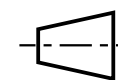
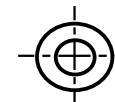

Question No:

**Geometric Drawings — 17**

# Geometric Drawing — 18

Draw, in the suggested positions, the following views of the sectioned five sided pyramid:

- a) Sectional Plan
- b) Sectional End
- c) Surface Development

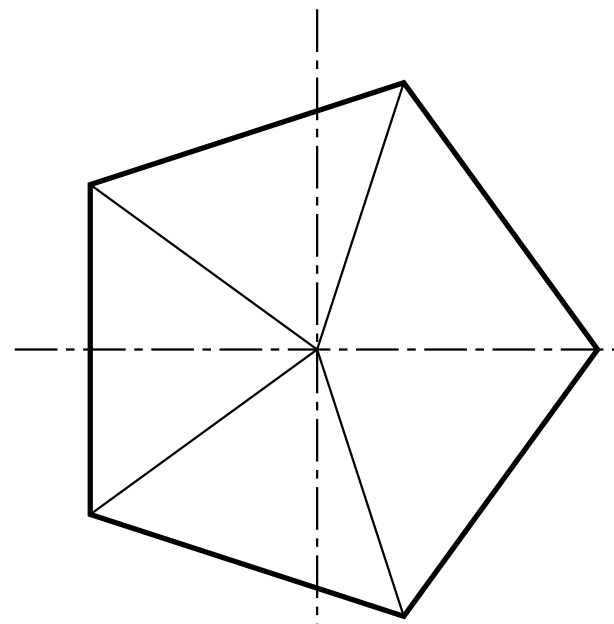

PLAN

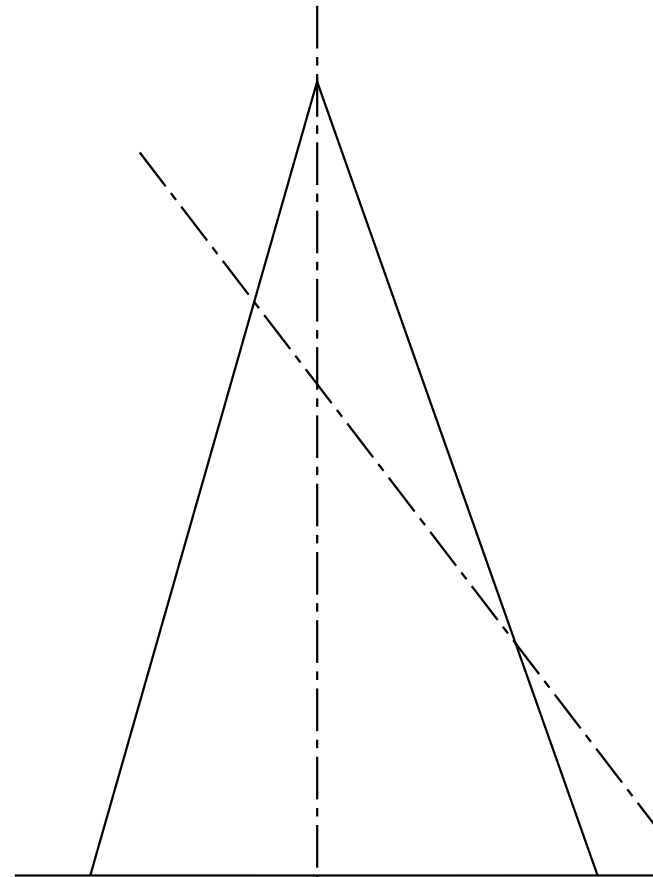

FRONT ELEVATION



END ELEVATION



SURFACE DEVELOPMENT

Name:

Class:

Date:

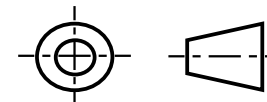

Question No:

# Geometric Drawing — 19

Draw, in the suggested positions, the following views of the sectioned cone:

- a) Sectional Plan
- b) Sectional End
- c) Surface Development

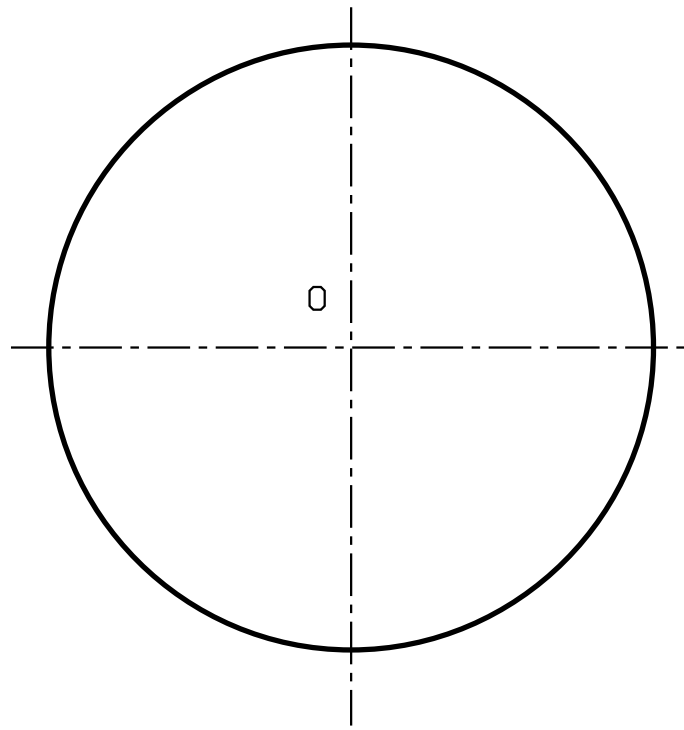

SECTIONAL PLAN

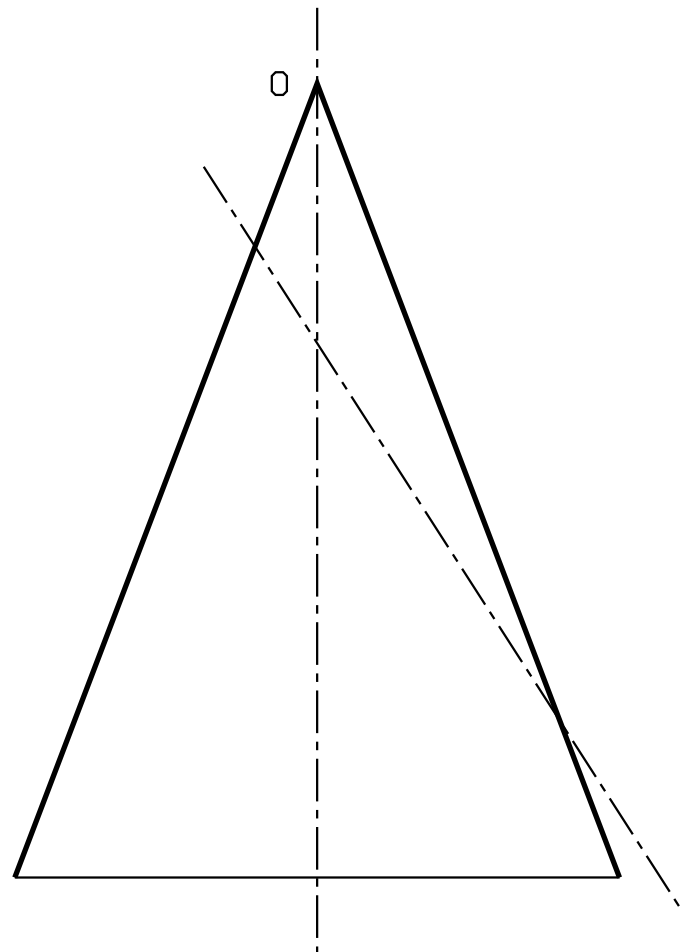

FRONT ELEVATION

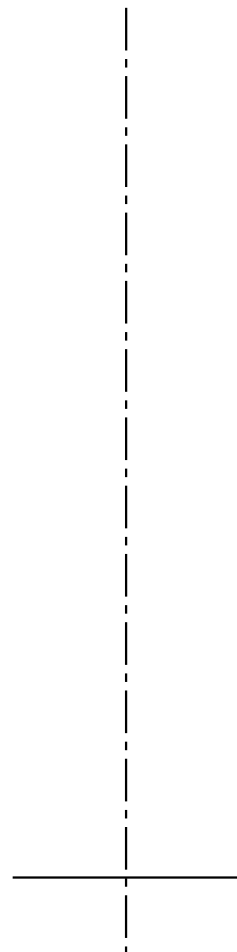

SECTIONAL END ELEVATION

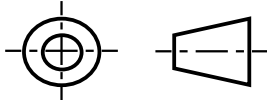

SURFACE DEVELOPMENT

Name:	Class:	Date:		Question No:	<b>Geometric Drawings — 19</b>
-------	--------	-------	---	--------------	--------------------------------

# Geometric Drawing — 20

Draw, in the suggested positions, the following views of the sectioned cone:

- a) Sectional Plan
- b) Sectional End
- c) Surface Development

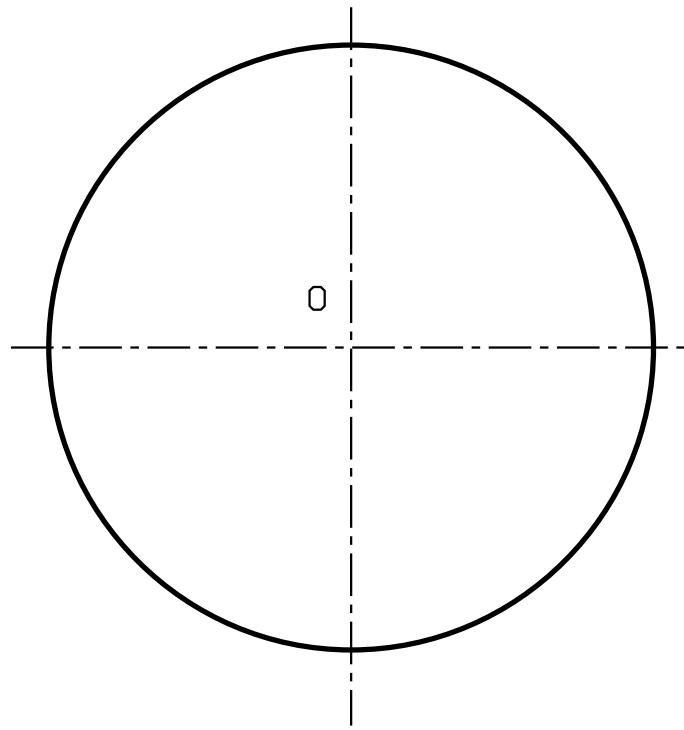

SECTIONAL PLAN

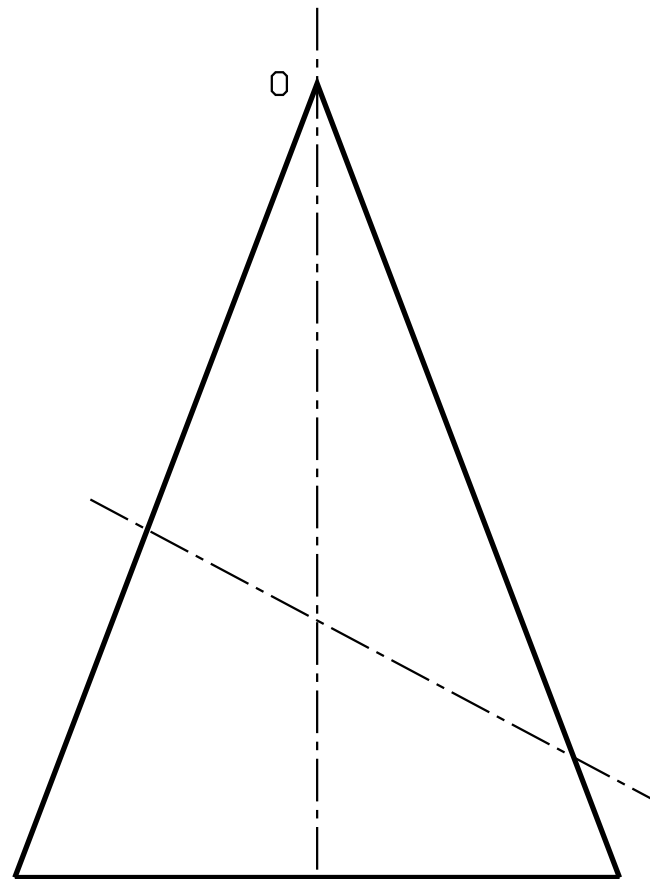

FRONT ELEVATION

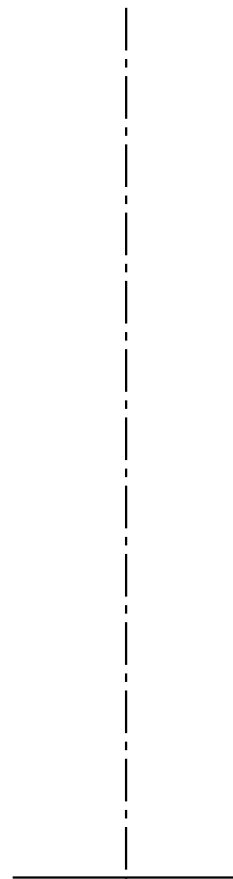

SECTIONAL END ELEVATION

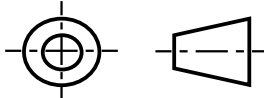

SURFACE DEVELOPMENT

Name:	Class:	Date:		Question No: <b>Geometric Drawings — 20</b>
-------	--------	-------	---	---

# Geometric Drawing — 21

Draw, in the suggested positions, the following views of the sectioned cone:

- a) Sectional Plan
- b) Sectional End
- c) Surface Development

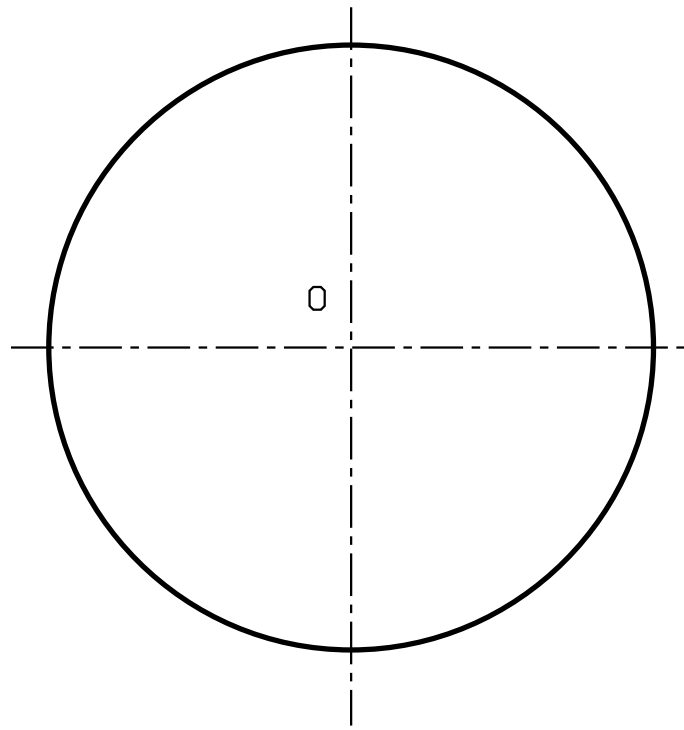

SECTIONAL PLAN

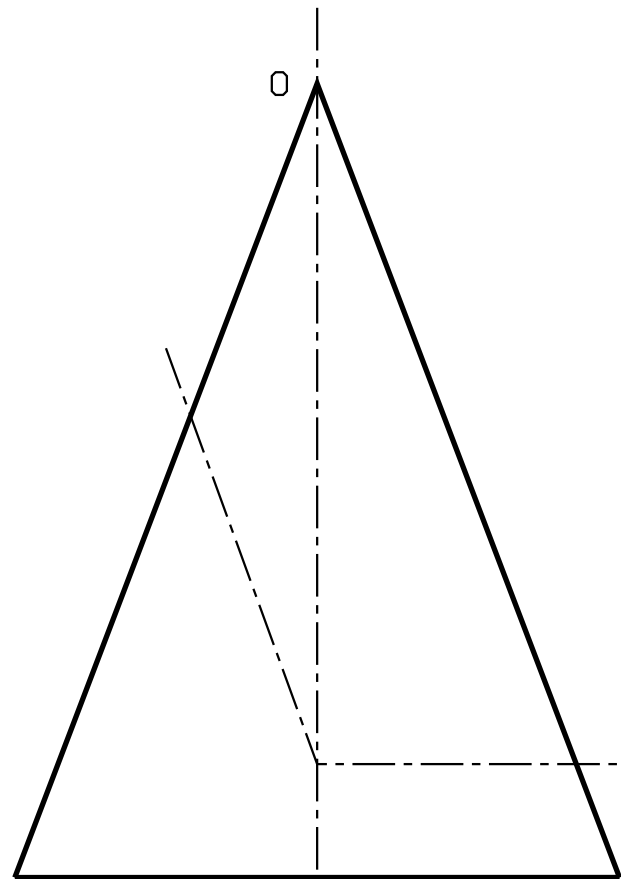

FRONT ELEVATION

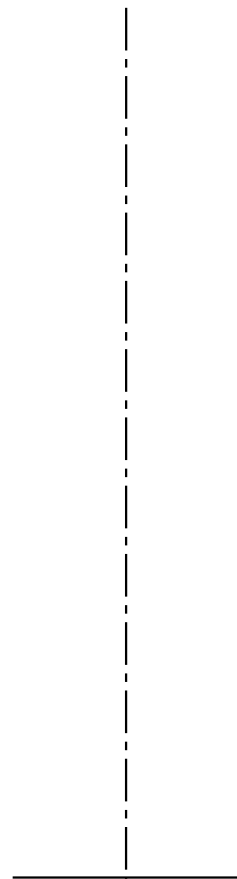

SECTIONAL END ELEVATION

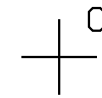

SURFACE DEVELOPMENT

Name:	Class:	Date:		Question No:	<b>Geometric Drawings — 21</b>
-------	--------	-------	--	--------------	--------------------------------

# Geometric Drawing — 22

Draw, in the suggested positions, the following views of the sectioned cone:

- a) Sectional Plan
- b) Sectional End
- c) Surface Development

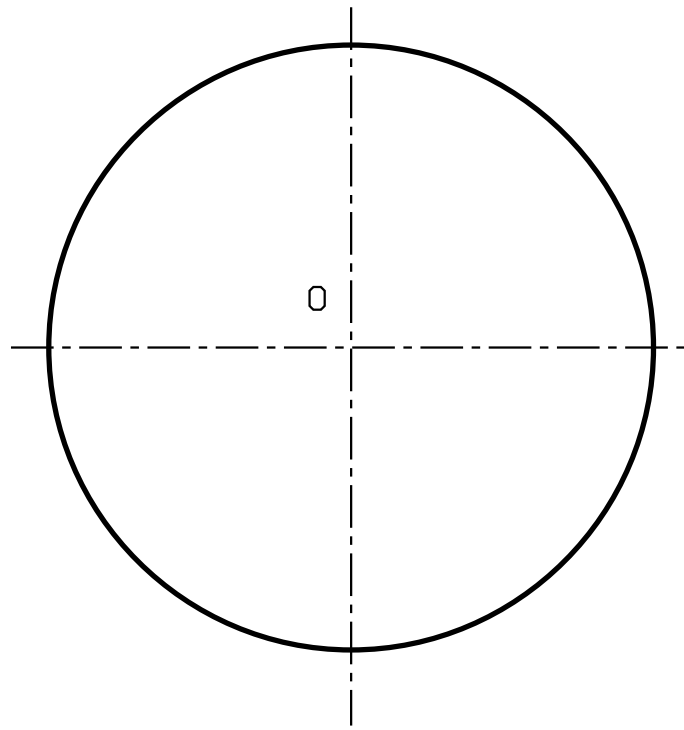

SECTIONAL PLAN

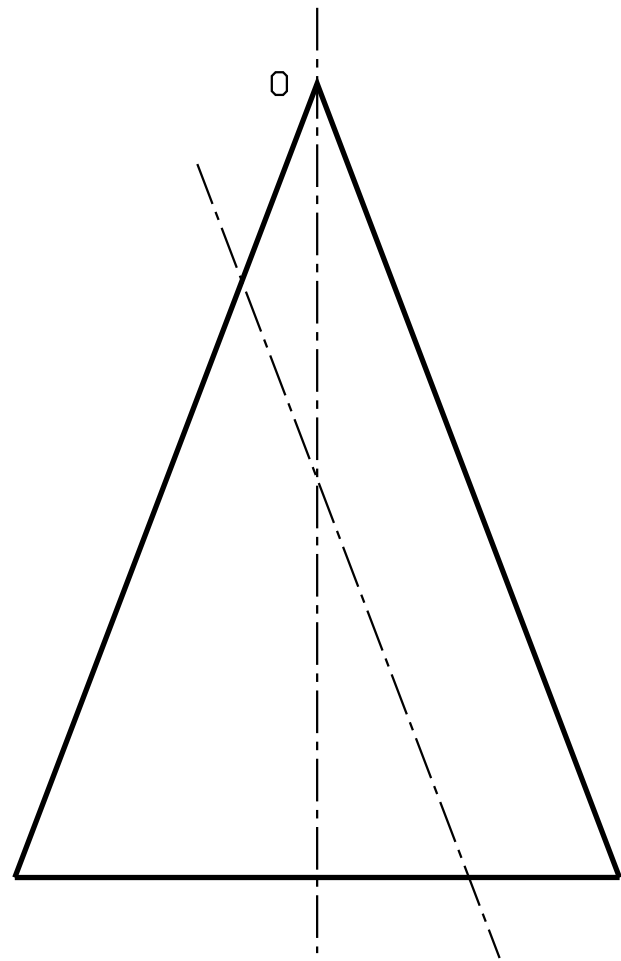

FRONT ELEVATION

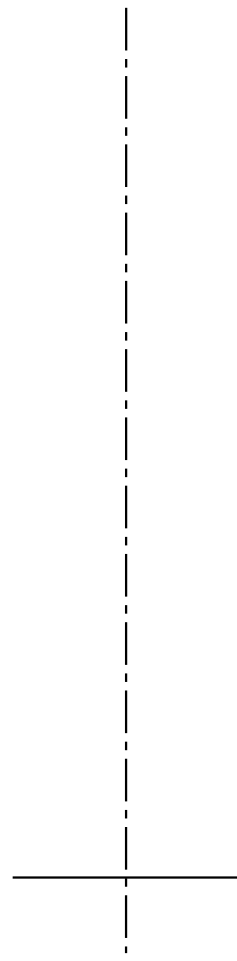

SECTIONAL END ELEVATION



SURFACE DEVELOPMENT

Name:

Class:

Date:

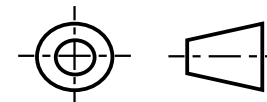

Question No:

# Geometric Drawing — 23

Draw, in the suggested positions, the following views of the sectioned cone:

- a) Sectional Plan
- b) Sectional End
- c) Surface Development

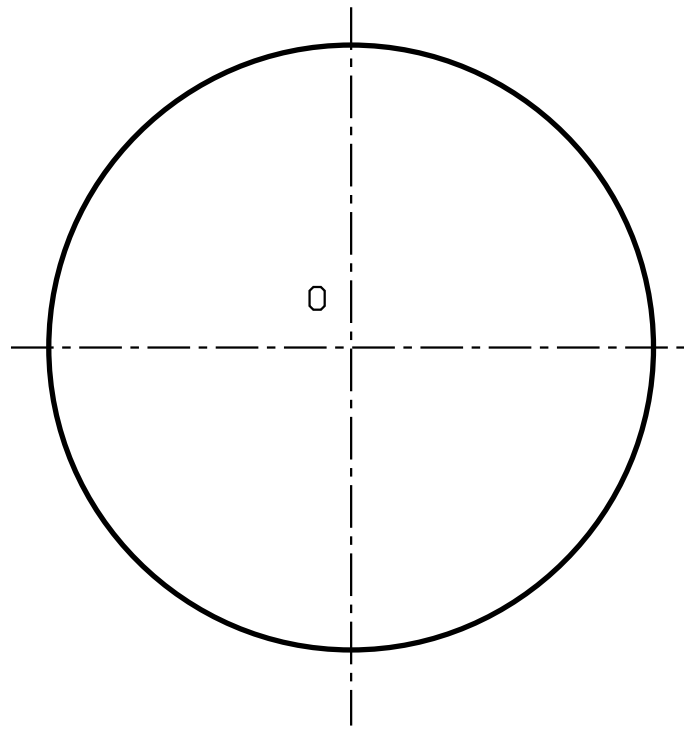

SECTIONAL PLAN

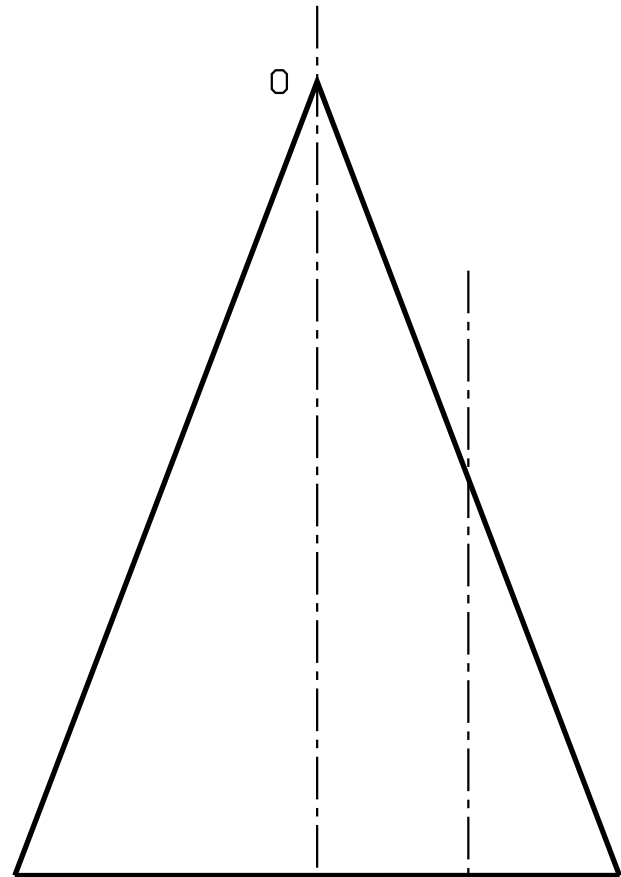

FRONT ELEVATION

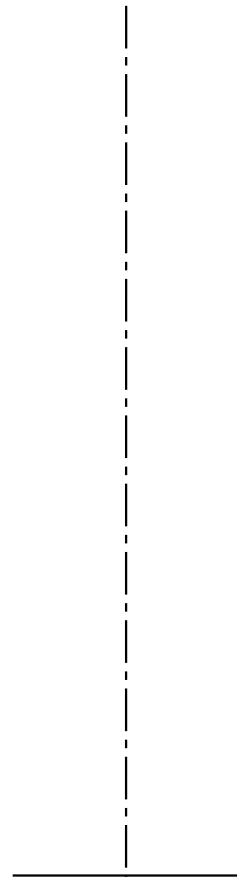

SECTIONAL END ELEVATION

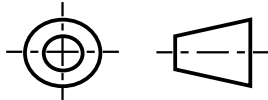

SURFACE DEVELOPMENT

Name:	Class:	Date:		Question No: <b>Geometric Drawings — 23</b>
-------	--------	-------	---	---



# Geometric Drawing — 24

Draw, in the suggested positions, the following views of the sectioned cone:

- a) Sectional Plan
- b) Sectional End
- c) Surface Development

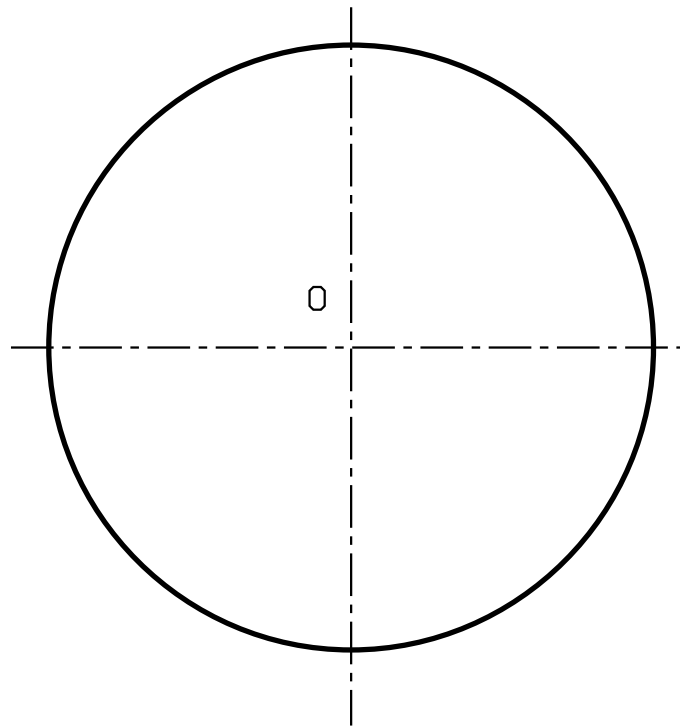

SECTIONAL PLAN

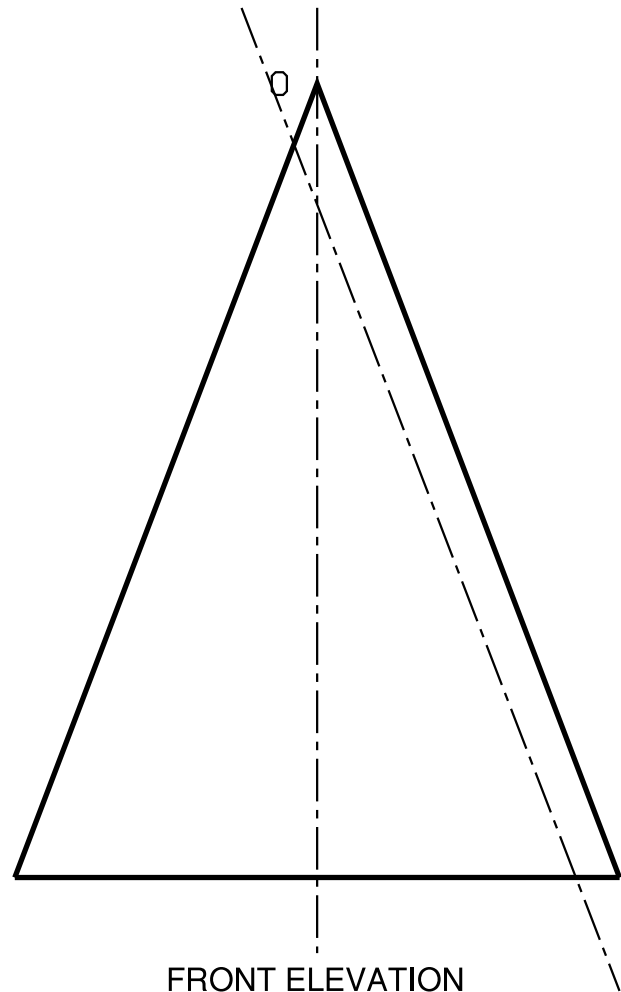

FRONT ELEVATION

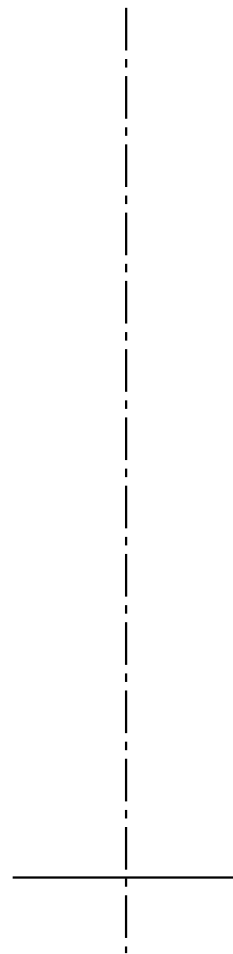

SECTIONAL END ELEVATION



SURFACE DEVELOPMENT

Name:

Class:

Date:

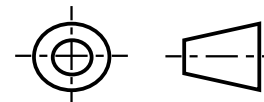

Question No: