

ISOMETRIC

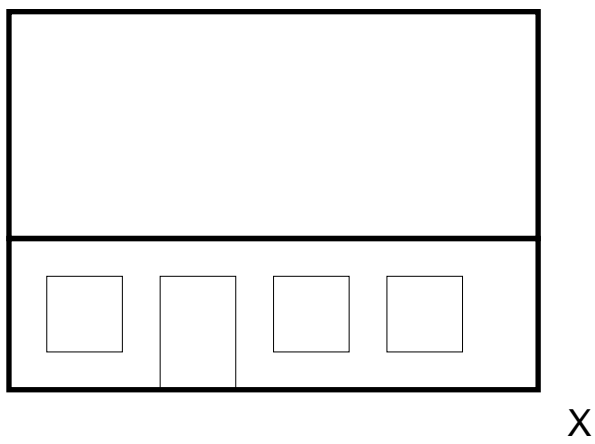

ELEVATION

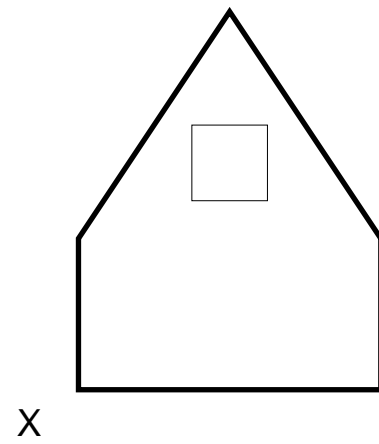

END

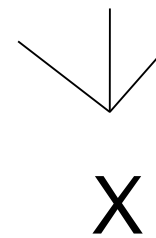

PERSPECTIVE SKETCH

Two Point Perspective — 1

Sketch, in the suggested position, a two point perspective drawing of the toy house, which is shown in the three views on the left.

Name:

Class:

Date:

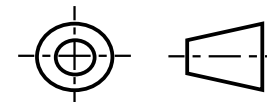

Question No:

Two Point Perspective Sketching — 1

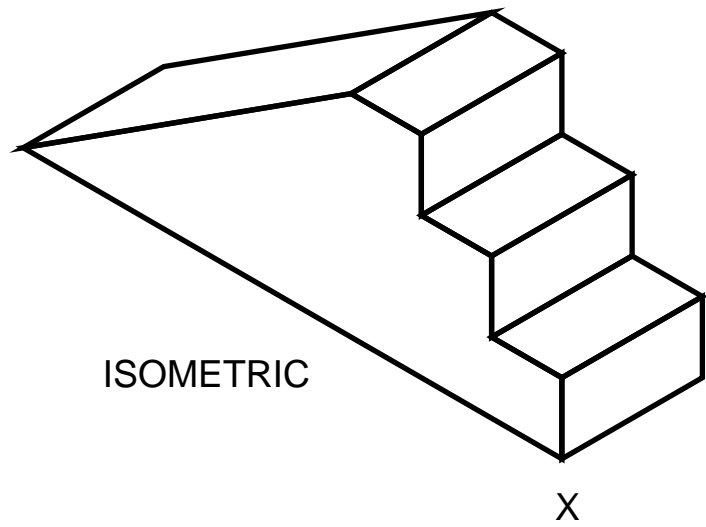
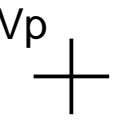
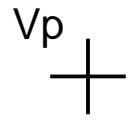

ISOMETRIC

X

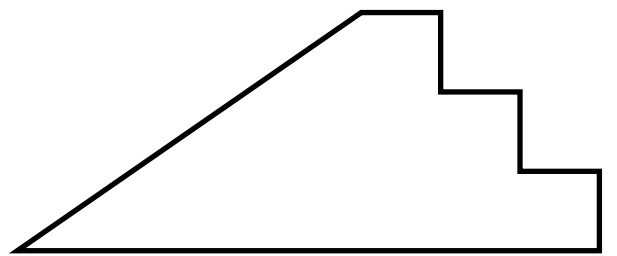

ELEVATION

X

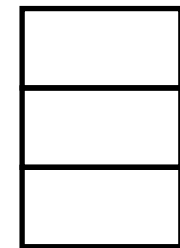

X

END

PERSPECTIVE SKETCH

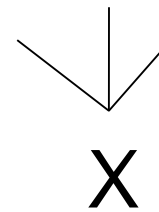

Two Point Perspective — 2

Sketch, in the suggested position, a two point perspective drawing of the doll's chute, which is shown in the three views on the left.

Name:

Class:

Date:

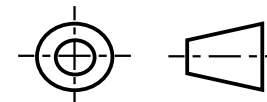

Question No:

Two Point Perspective Sketching — 2

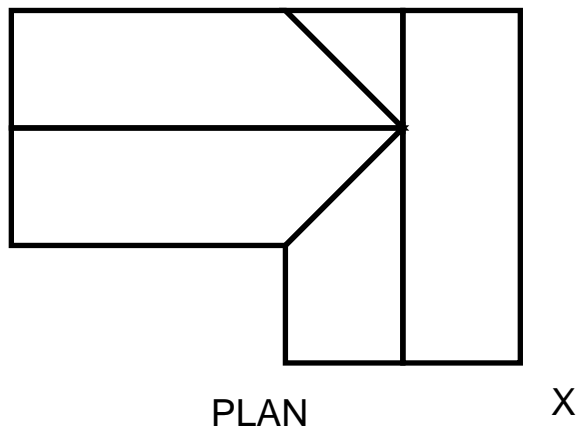
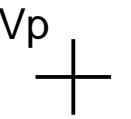
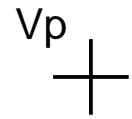

PERSPECTIVE SKETCH

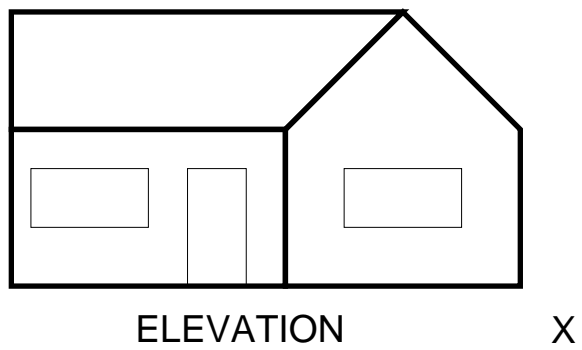
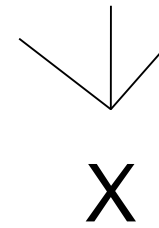

Two Point Perspective — 3

Sketch, in the suggested position, a two point perspective drawing of the cottage shown in the two views on the left.

Name:

Class:

Date:

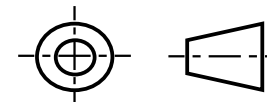

Question No:

Two Point Perspective Sketching — 3

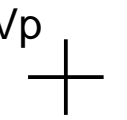
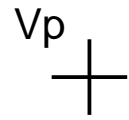

Two Point Perspective — 4

Sketch, in the suggested position, a two point perspective drawing of the shaped building block shown in the two views below.

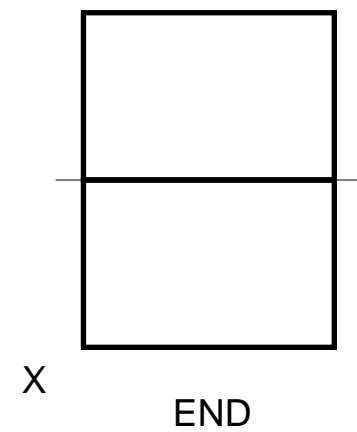
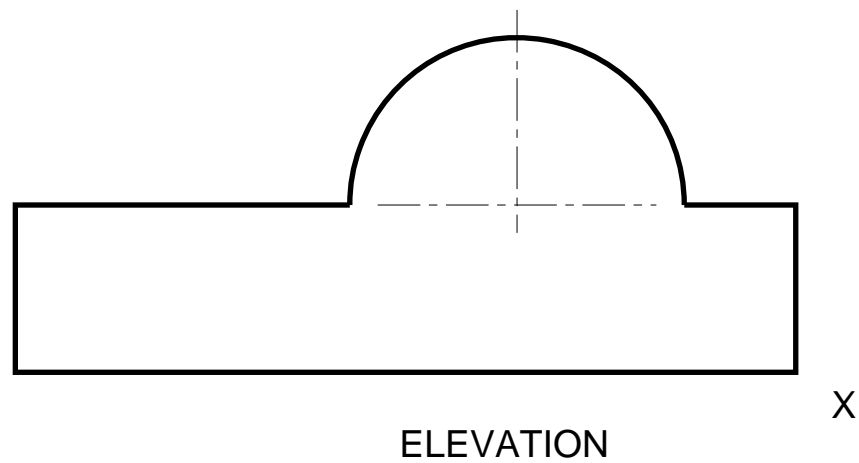

Name:	Class:	Date:		Question No: Two Point Perspective Sketching — 4
-------	--------	-------	--	--

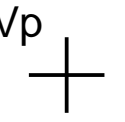
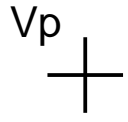

Two Point Perspective — 5

Sketch, in the suggested position, a two point perspective drawing of the front of a local mosque, which is shown in the two views below.

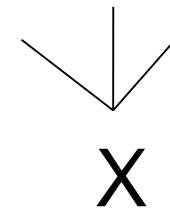
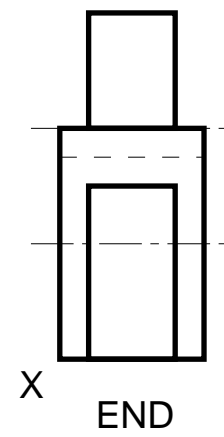
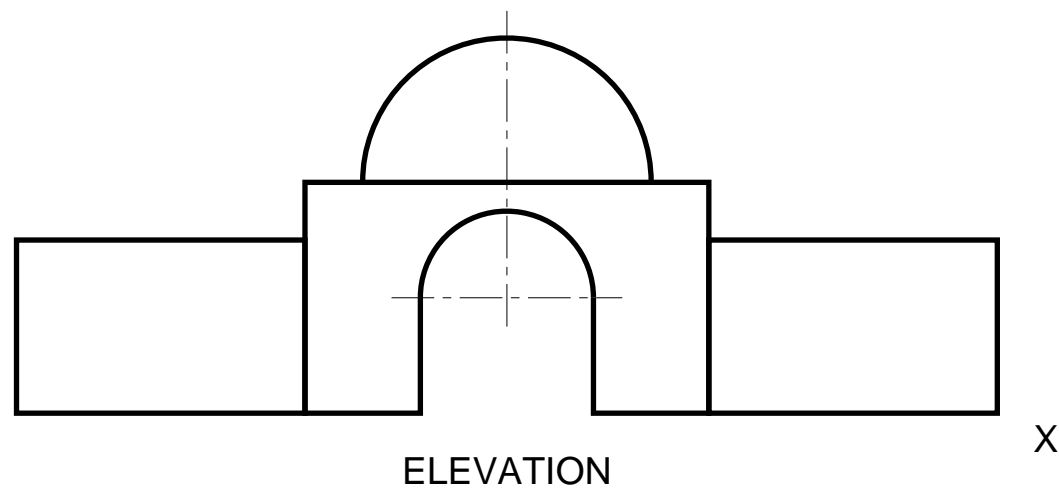

PERSPECTIVE SKETCH

Name:

Class:

Date:

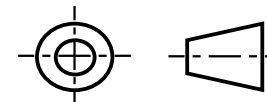

Question No:

Two Point Perspective Sketching — 5

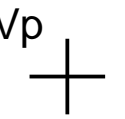
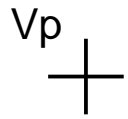

Two Point Perspective — 6

Sketch, in the suggested position, a two point perspective drawing of the row of shops shown in the two views below.

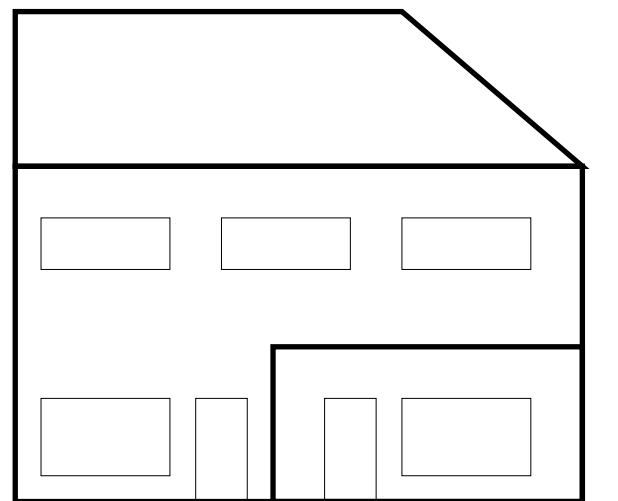

ELEVATION

X

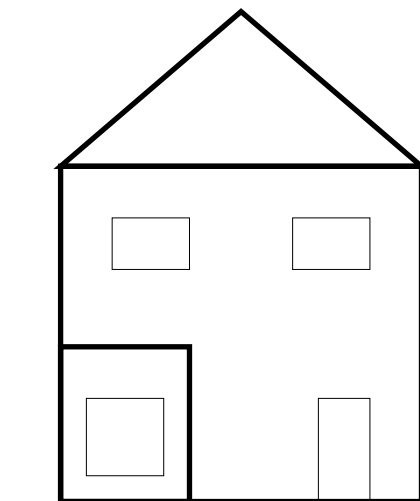

END

X

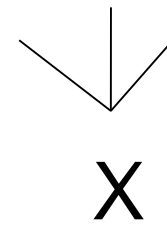

PERSPECTIVE SKETCH

Name:

Class:

Date:

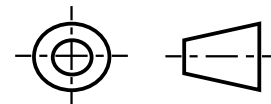

Question No:

Two Point Perspective Sketching — 6

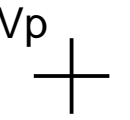
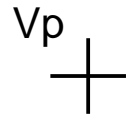

Two Point Perspective — 7

Sketch, in the suggested position, a two point perspective drawing of the house with attached garage, which is shown below.

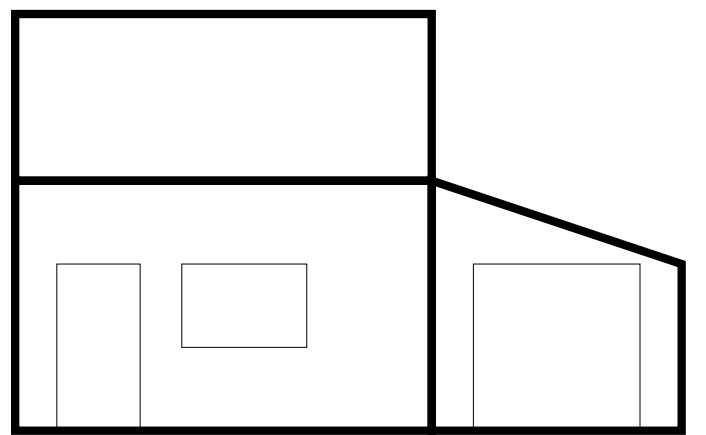

ELEVATION

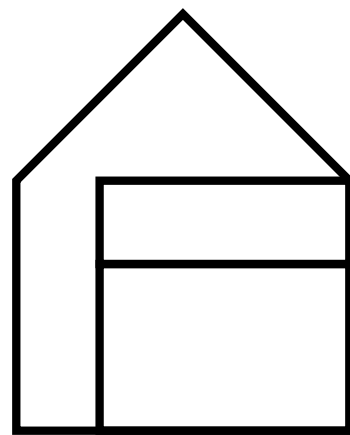

END

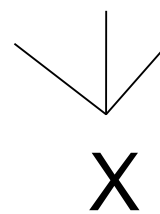

PERSPECTIVE SKETCH

Name:

Class:

Date:

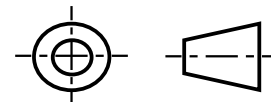

Question No:

Two Point Perspective Sketching — 7

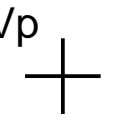
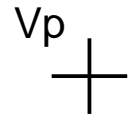

TWO POINT PERSPECTIVE

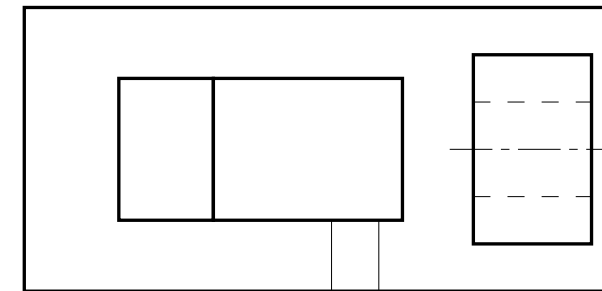
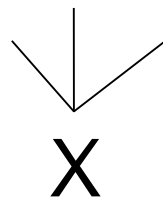

X

PLAN

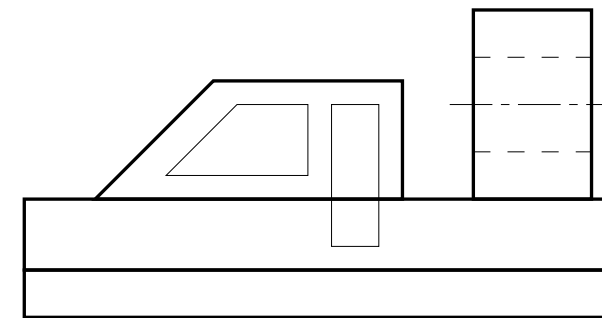

X

FRONT

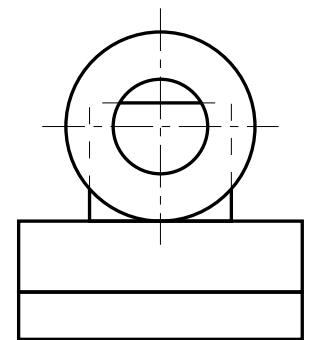

END

Two Point Perspective — 8

Sketch, in the suggested position, a two point perspective drawing of the hovercraft shown in the three views on the right.

Name:

Class:

Date:

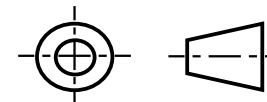

Question No:

Two Point Perspective Sketching — 8