

# Orthographic Assembly — 1

Draw, in the suggested positions, the following assembled views of the Medal Stand:

- a) Front Elevation;
- b) End Elevation looking from the right;
- c) Plan;
- d) Sectional End Elevation on "J-J".

*Show all hidden detail.*

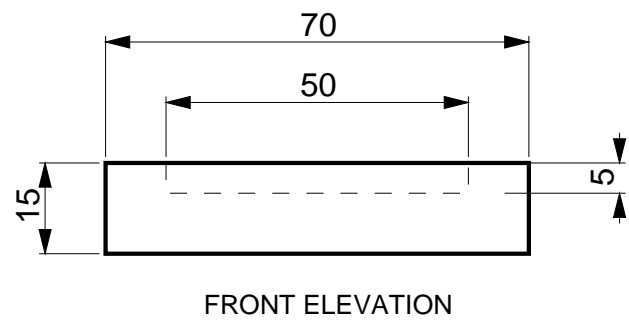
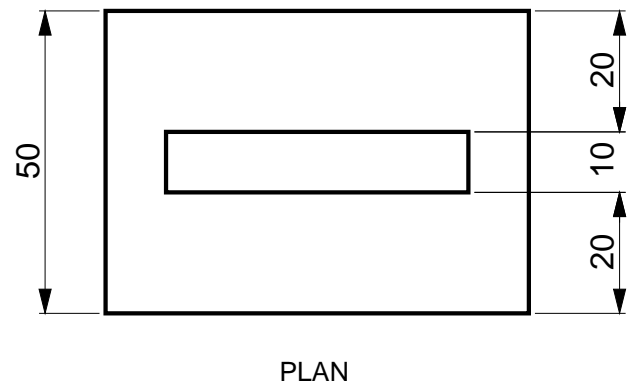
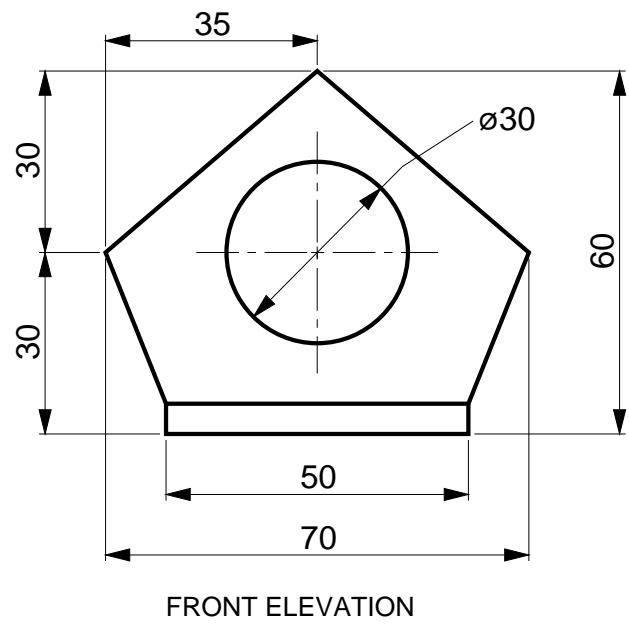
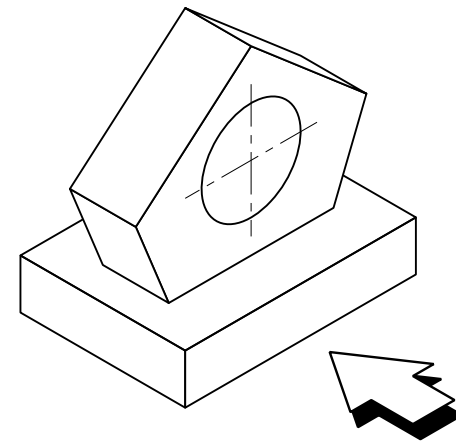
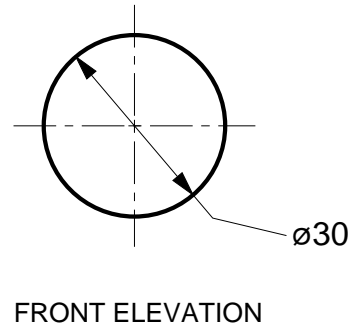
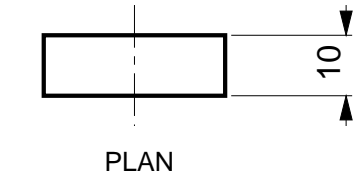
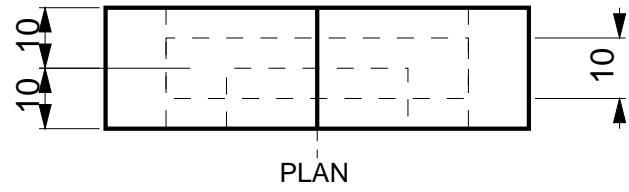

SECTIONAL END ON J-J

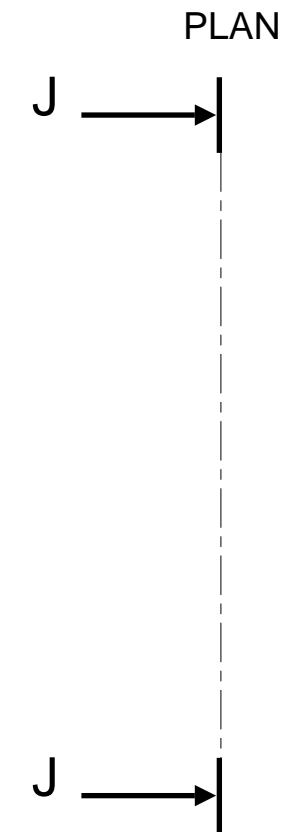

FRONT ELEVATION

END ELEVATION

Name:	Class:	Date:		Question No:	<b>Orthographic Assemblies — 1</b>
-------	--------	-------	--	--------------	------------------------------------

# Orthographic Assembly — 2

Draw, in the suggested positions, the following assembled views of the clock movement:

- a) Front Elevation;
- b) Plan;
- c) Sectional End Elevation on "B-B".

Show all hidden detail.

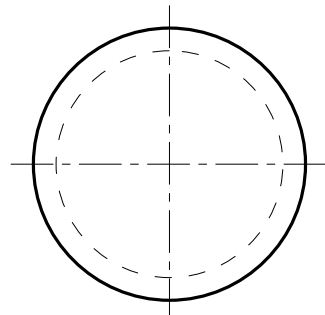

FRONT ELEVATION

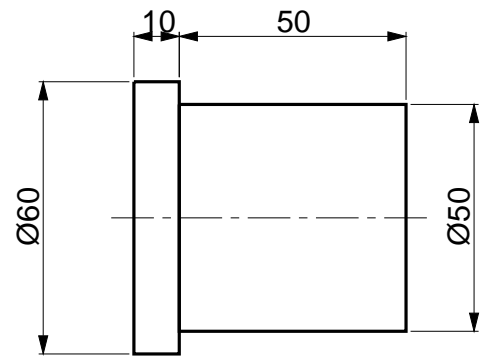

END ELEVATION

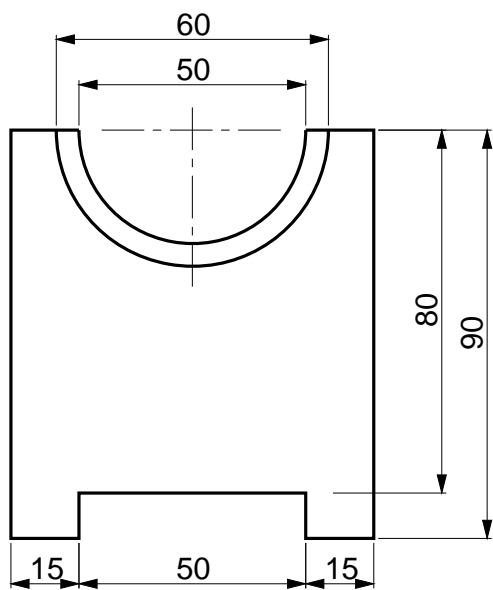

FRONT ELEVATION

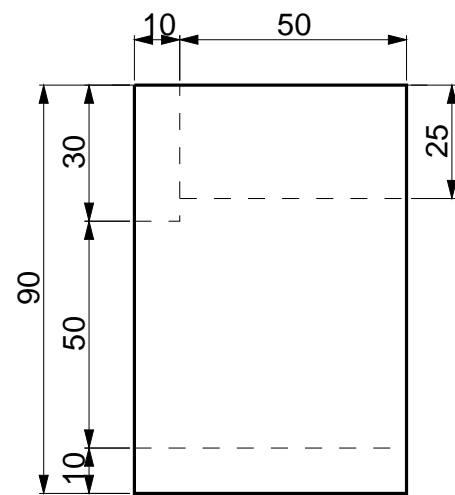

END ELEVATION

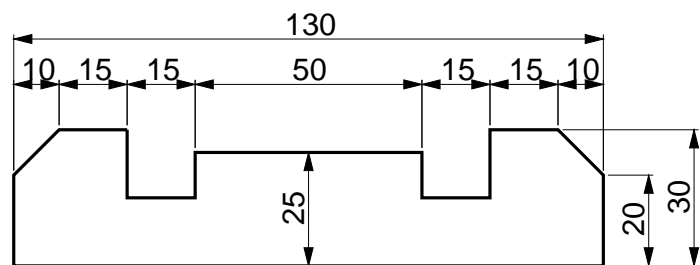

FRONT ELEVATION

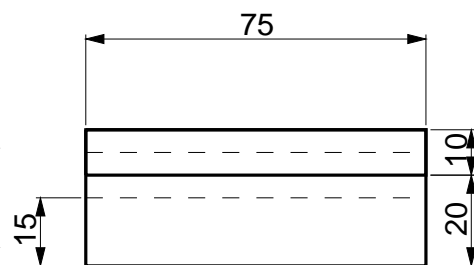

END ELEVATION

SECTIONAL END ON B-B

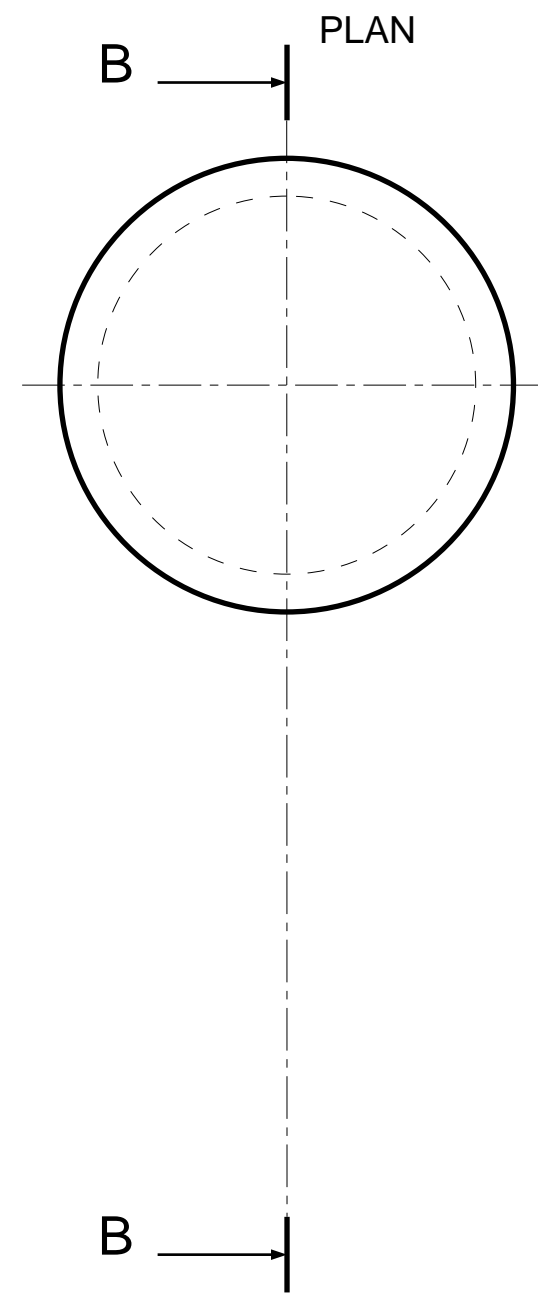

FRONT ELEVATION

Name:

Class:

Date:

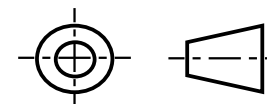

Question No:

**Orthographic Assemblies — 2**

### Orthographic Assembly — 3

Draw, in the suggested positions, the following assembled views of the Spice Jar:

- a) Front Elevation;
- b) Plan;
- c) Sectional End Elevation taken from the centre of the Front.

Show all hidden detail.

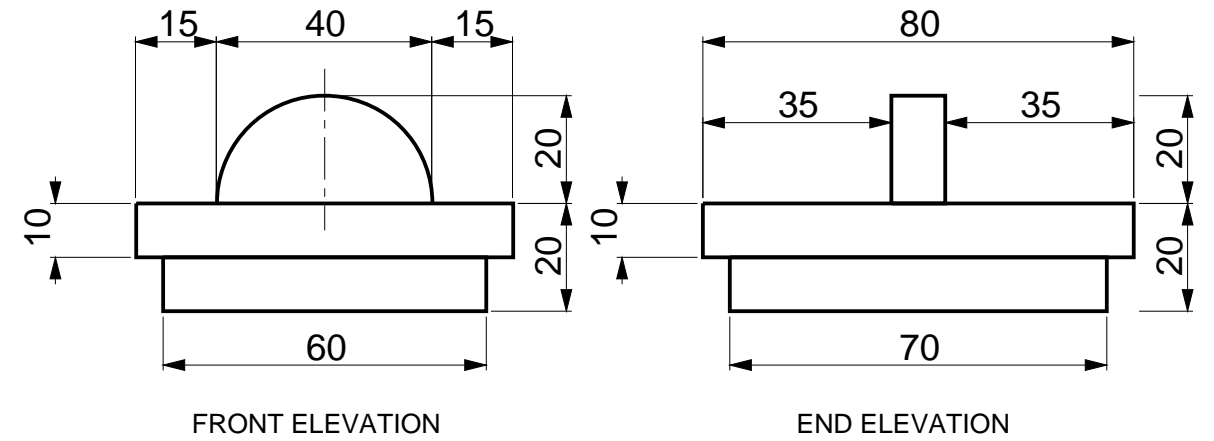

PLAN

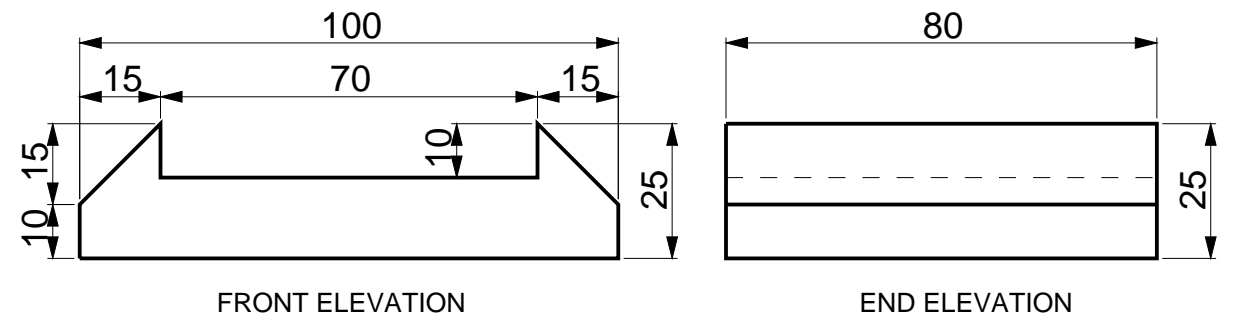
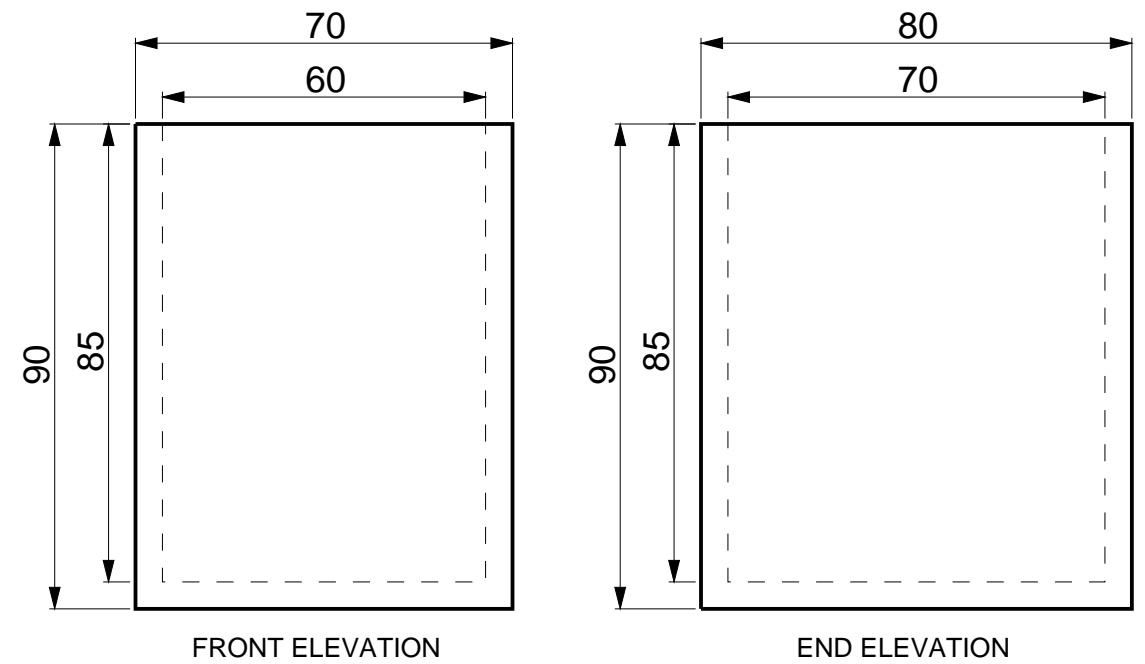

FRONT ELEVATION

SECTIONAL END

Name:

Class:

Date:

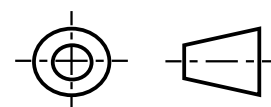

Question No:

**Orthographic Assemblies — 3**

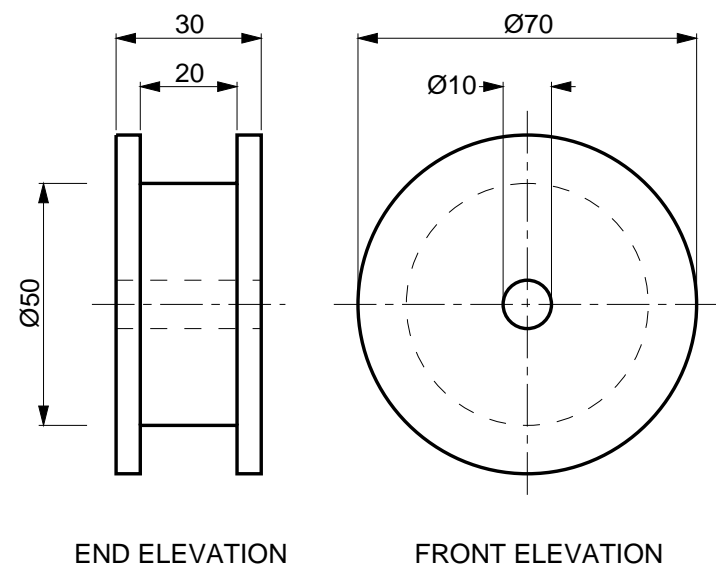
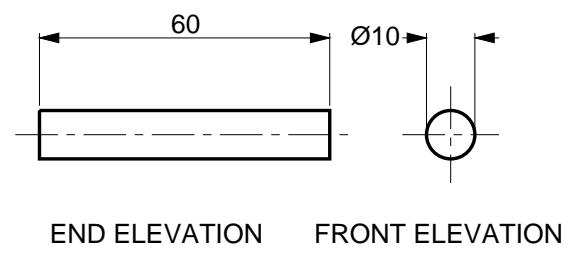
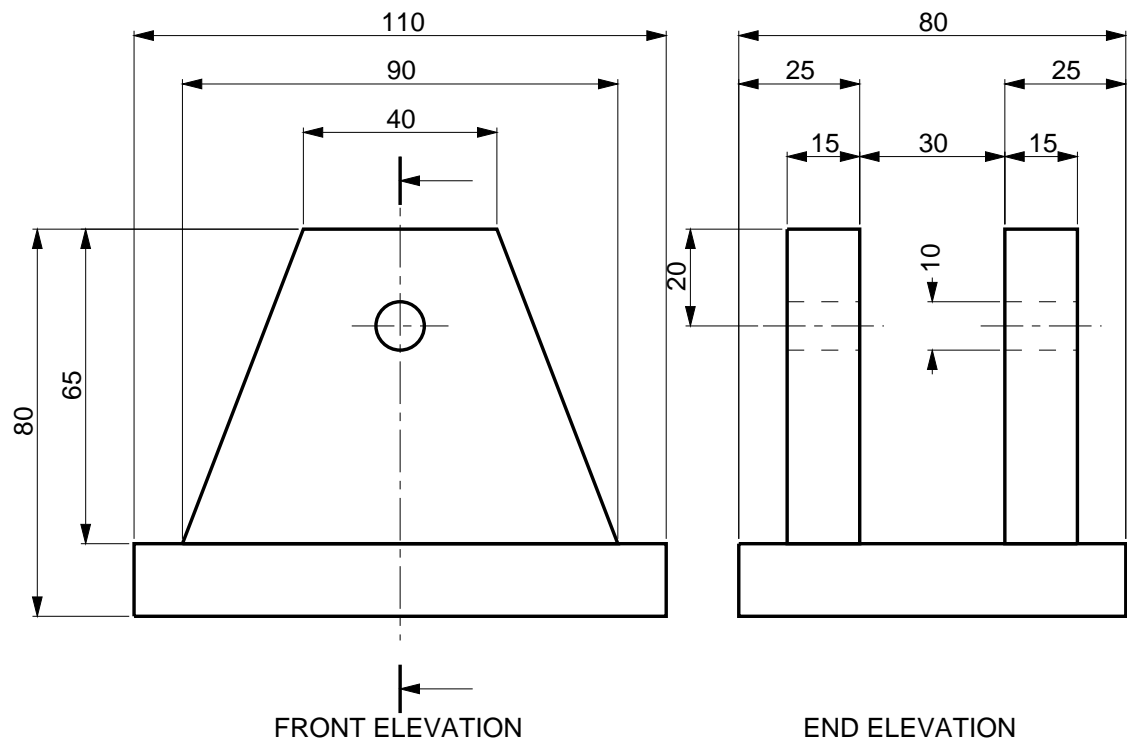

### Orthographic Assembly — 4

Draw, in the given positions, the following assembled views of the Sellotape Holder:

- a) Front Elevation;
- b) End Elevation looking from the left;
- c) Sectional End Elevation on "D-D".

Show all hidden detail.

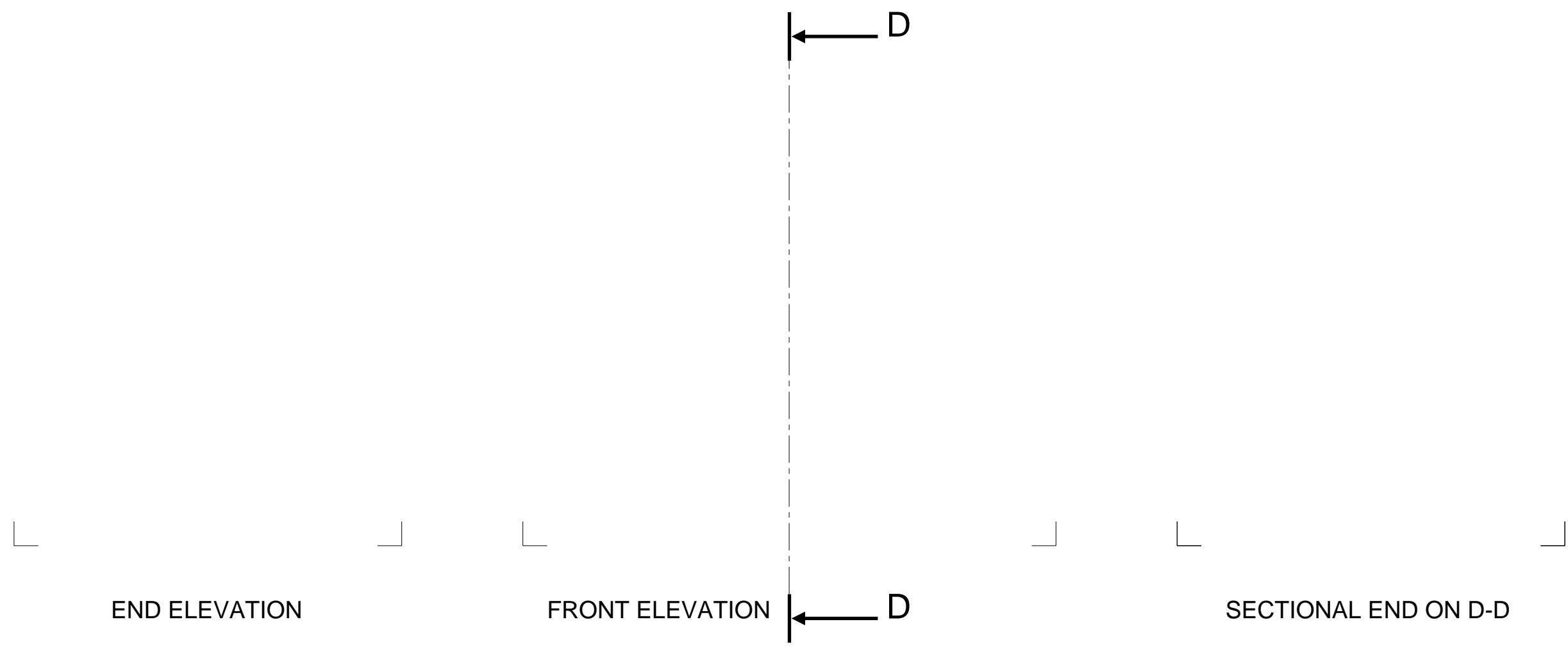

Name:	Class:	Date:		Question No: <b>Orthographic Assemblies — 4</b>
-------	--------	-------	--	---

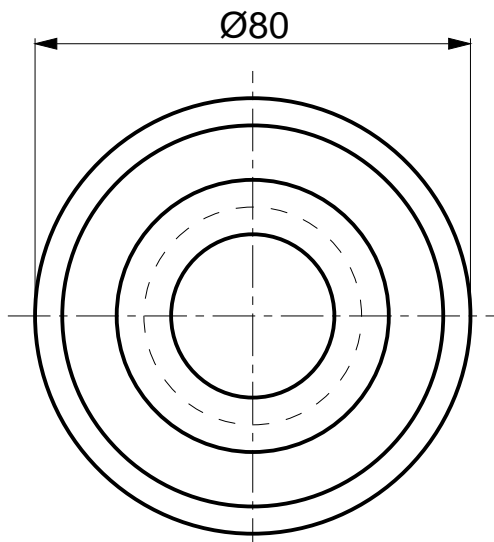

PLAN

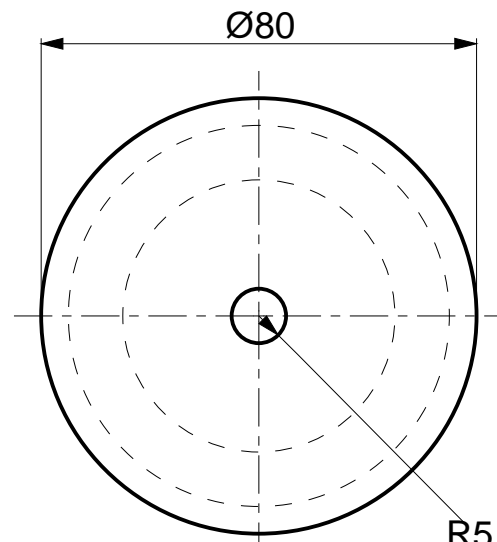

PLAN

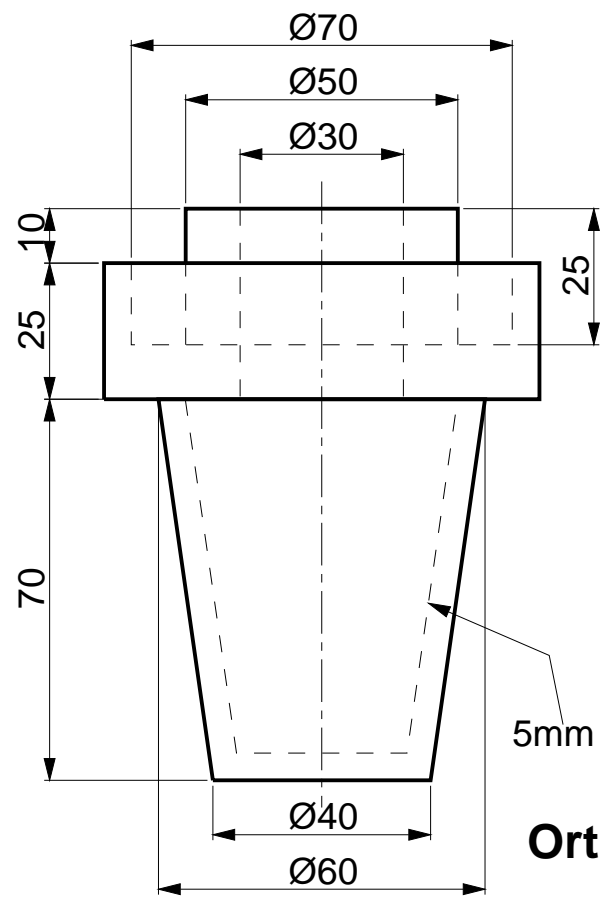

FRONT ELEVATION

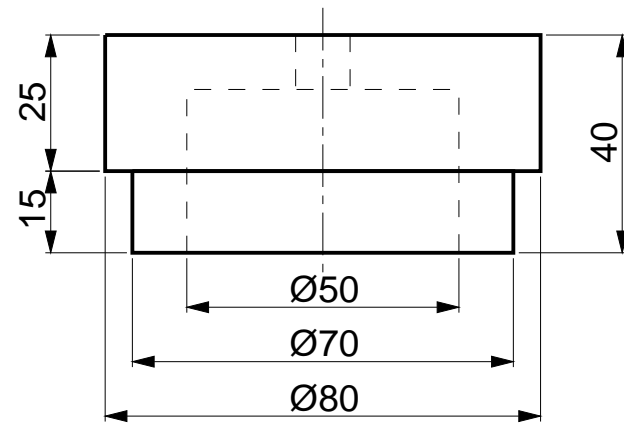

FRONT ELEVATION

5mm Wall Thickness

### Orthographic Assembly — 5

Draw, in the suggested positions, the following assembled views of the Chalk Dust Dispenser:

- a) Front Elevation;
- b) Plan;
- c) Sectional End Elevation on "F-F".

Show all hidden detail.

SECTIONAL END ON F-F

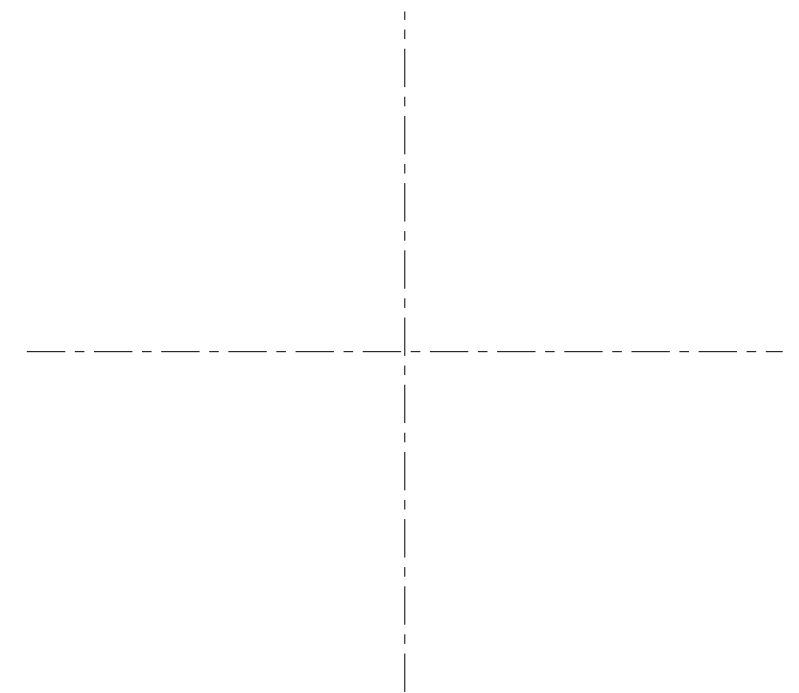

PLAN

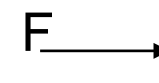
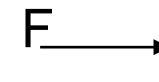

FRONT ELEVATION

Name:

Class:

Date:

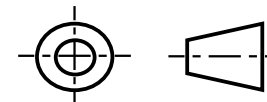

Question No:

**Orthographic Assemblies — 5**

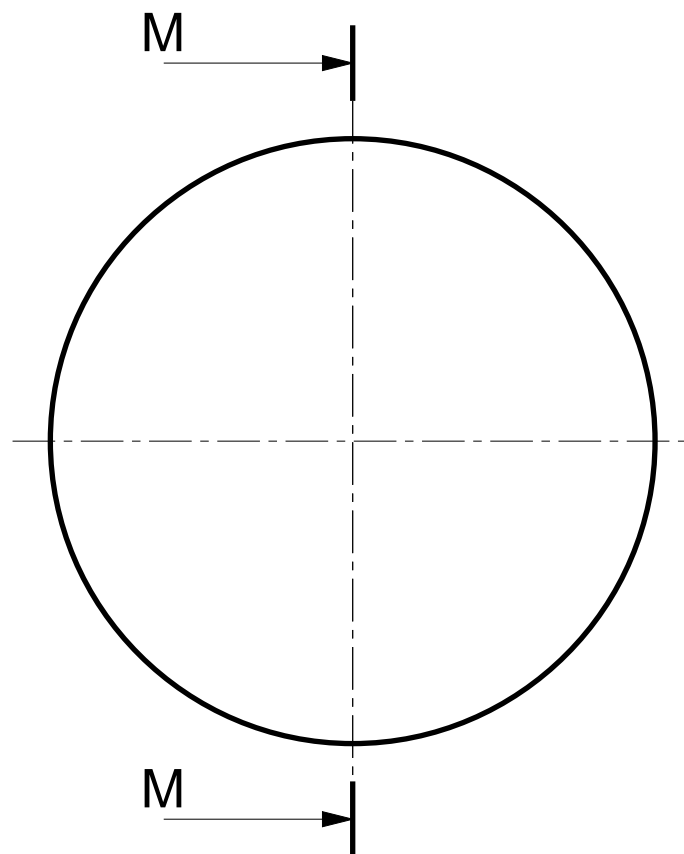

FRONT ELEVATION

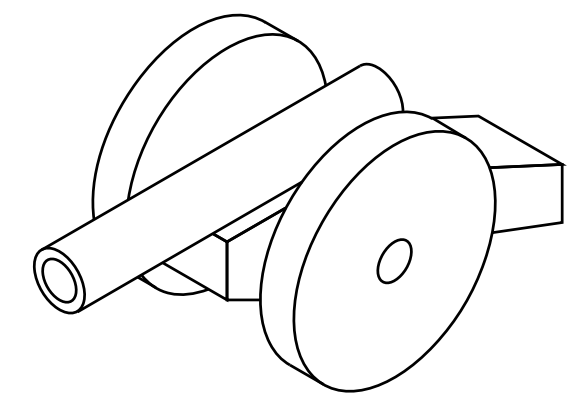

ISOMETRIC

**Orthographic Assembly — 6**

Draw, in the suggested positions, the following assembled views of the given Toy Cannon:

- a) Front Elevation;
- b) Sectional End Elevation.

*Show all hidden detail.*

SECTIONAL END ON M-M

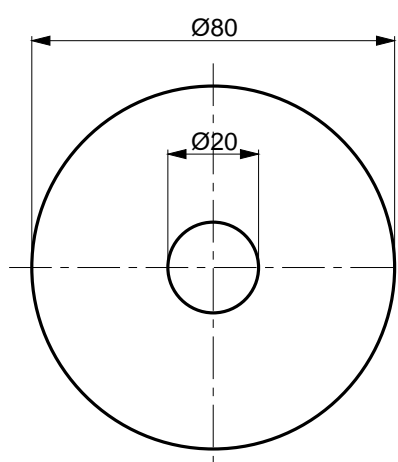

FRONT ELEVATION

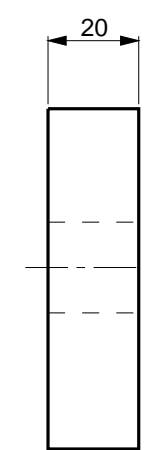

END ELEVATION

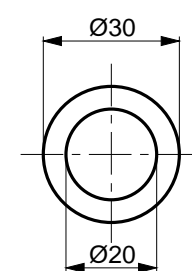

FRONT ELEVATION

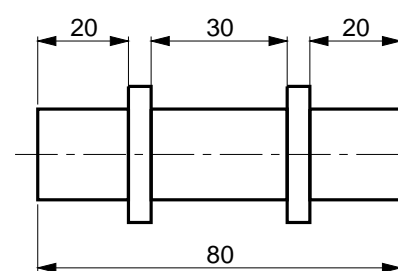

END ELEVATION

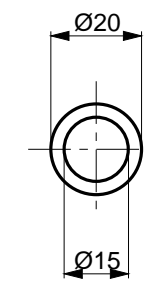

END ELEVATION

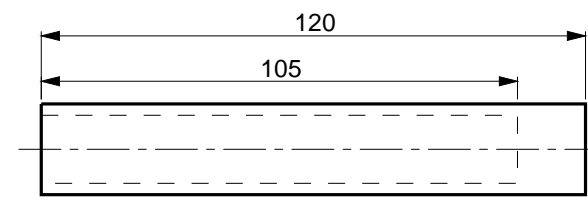

FRONT ELEVATION

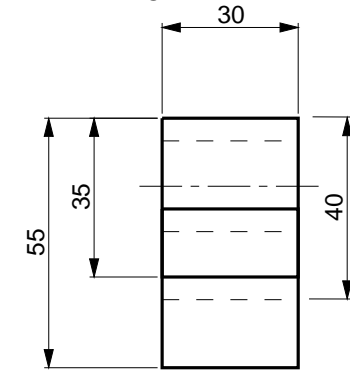

END ELEVATION

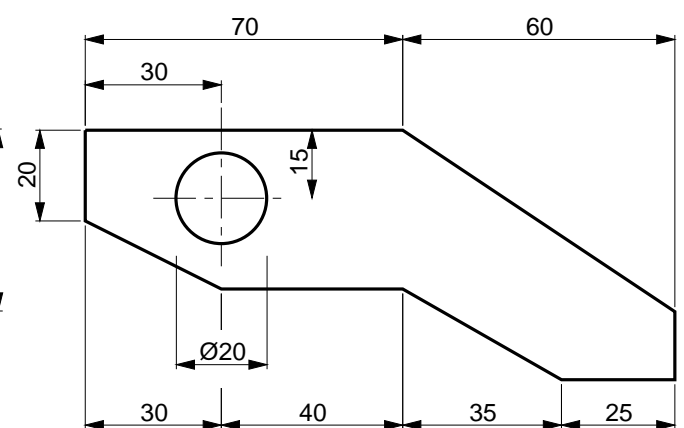

FRONT ELEVATION

Name:	Class:	Date:		Question No: <b>Orthographic Assemblies — 6</b>
-------	--------	-------	--	---