

Particles and Waves Homework One

1. A car covers a distance of 170m in a time of 18s. Calculate the average speed of the car. (2)
2. Calculate the value of a resistor, which has 4.5mA of current flowing through it when it is connected to a 9.0kV supply. (2)
3. Calculate the potential energy gained by an object of mass 35kg, when it is raised through a vertical height of 6.3m. (2)
4. A star is travelling away from Earth with a red shift of 0.077. Calculate the speed at which the star is travelling. (2)
5. An electron (mass 9.11×10^{-31} kg) is travelling at 2.4×10^5 ms⁻¹. Calculate the value of the electron's kinetic energy. (2)

Particles and Waves Homework Two

1. A Physics textbook contains the following diagram of an atom.

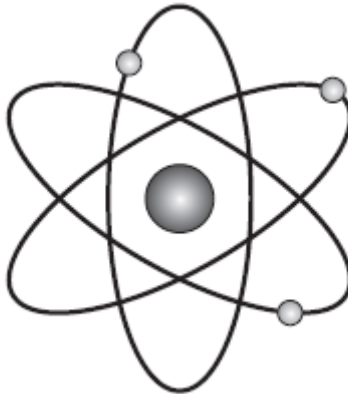

- a) Which elementary particle is shown in the diagram? (1)
- b) Before the standard model was established, what were the names of the two particles that were thought to make up the nucleus of an atom? (2)
- c) The standard model shows that the nucleus of an atom contains which elementary particle? (1)

Particles and Waves Homework Two

2.

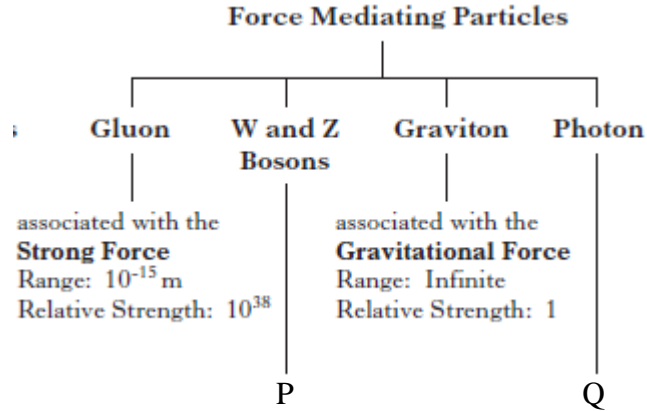

Copy and complete the above key by inserting the appropriate data at parts P and Q. (4)

3. Use the appropriate symbols to re-write the following word equation for beta decay.

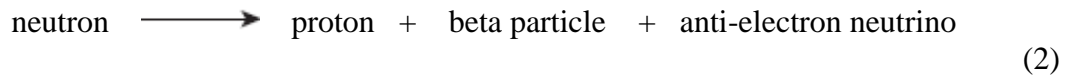

Particles and Waves Homework Three

1. Draw the electric field pattern for a positive point charge. (1)

2. What is meant by the expression “a potential difference of 12V exists between two points”? (1)

3. A potential difference, V , is applied between two metal plates. A charge of $+4.0\text{mC}$ is released from the positively charged plate as shown.

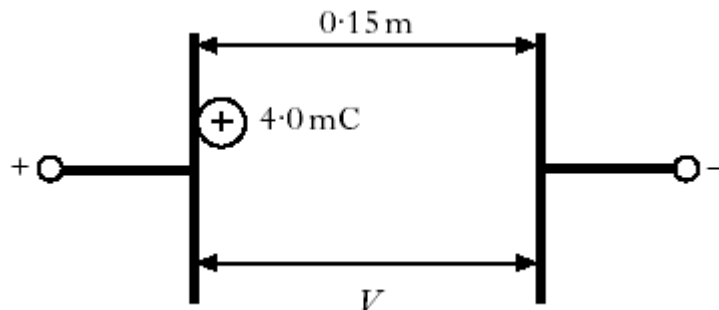

The work done in moving the charge to the negative plate is 8.0J. Calculate the potential difference between the plates. (2)

4. An electron is accelerated from rest through a potential of 100V. Calculate:
a) the kinetic energy gained by the electron. (3)

b) the final speed of the electron. (3)

(You should know the charge and mass of electron!)

Particles and Waves Homework Four

1. Copy the following diagram.

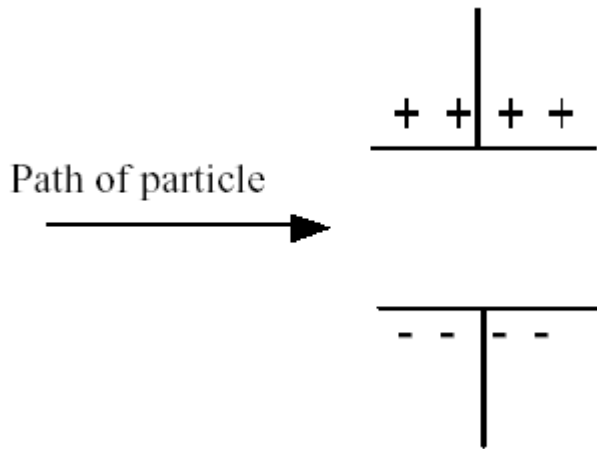

Complete the diagram by showing the path taken by the following as they pass through the electric field.

- a) beta particle
 - b) alpha particle
 - c) gamma rays
- (4)

2. Draw the magnetic field pattern for a permanent magnet. Clearly label the North and South Poles. (2)

3. A student makes the following statements about magnet fields.
- A) A current carrying wire is surrounded by a circular magnetic field.
 - B) Neutrons are not deflected by a magnetic field.
 - C) A magnetic north pole will always be attracted to another magnetic north pole.

State whether each statement is true or false. (3)

4. The following diagram shows a simplified part of a mass spectrometer.

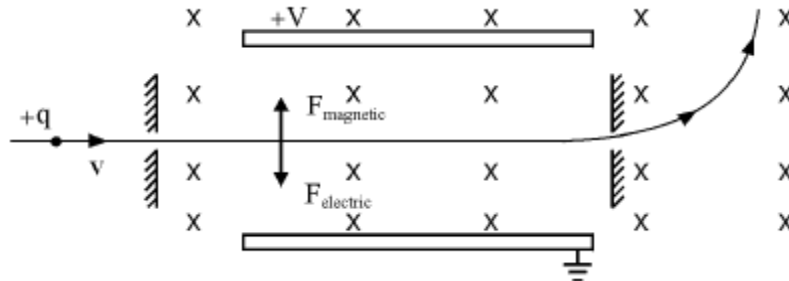

When the charged particle, $+q$, enters the region where there is only a magnetic field acting it moves in an upwards direction. In which direction does the magnetic field act?

(1)

Particles and Waves Homework Five

1. The following statement represents a nuclear decay.

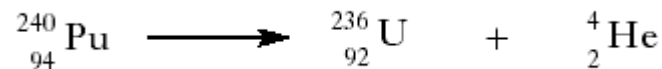

- Which type of decay does the above statement represent?
- State the number of protons in the plutonium (Pu) nucleus.
- State the number of neutrons in the uranium (U) nucleus.

(3)

2. The following statement represents a nuclear reaction that could take place inside a star.

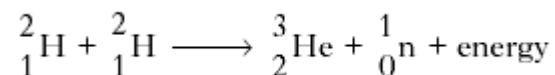

The total mass of the particles before the reaction is $6.684 \times 10^{-27}\text{kg}$.
The total mass of the particles after the reaction is $6.680 \times 10^{-27}\text{kg}$.

- Which type of reaction does the above statement represent?
- Calculate the energy released by the nuclear reaction.

(3)

3. The following statement represents a nuclear decay.

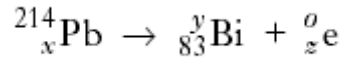

- a) Which type of decay does the above statement represent?
 b) State the values represented by x , y and z .

(4)

4. The following statement represents a nuclear reaction that could take place in a nuclear reactor.

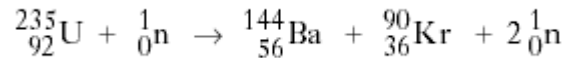

The masses of the particles in this reaction are shown in the table below.

Particle	Mass (kg)
Uranium-235	3.9014×10^{-25}
Barium-144	2.3894×10^{-25}
Krypton-90	1.4920×10^{-25}
Neutron	1.6750×10^{-27}

- a) Which type of reaction does the above statement represent?
 b) Calculate the energy released by the nuclear reaction.

(4)

Particles and Waves Homework Six

1. Which wave term can be defined as “the number of complete waves which pass a point in a second”? (1)
2. What is the definition of the wave term “period”? (1)
3. Which four characteristics are exhibited by all waves? (2)
4. What happens to the frequency and wavelength of a wave that has undergone a plane mirror reflection? (2)
5. The following diagram gives information about a wave.

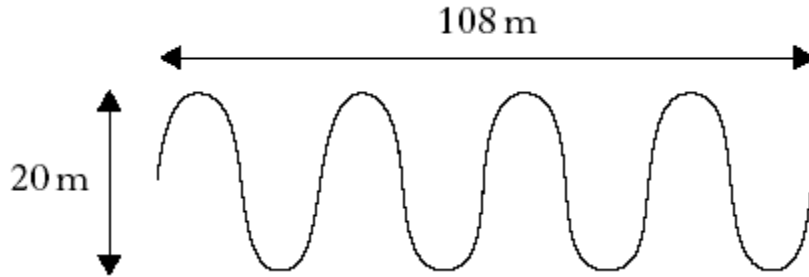

- a) State the amplitude of this wave.
 b) State the wavelength of this wave. (2)
6. An ultrasonic wave, traveling through air, has a wavelength of 4mm. Calculate the frequency of this wave in air? (2)

Particles and Waves Homework Seven

1. Explain the main differences between constructive and destructive interference. (2)
2. Two coherent sources of sound waves produce an interference pattern. If the path difference to the fourth order maximum is 20cm, what is the wavelength of the sources? What is the frequency of these waves? (4)
3. In Q.2 what is the path difference to the 2nd order minimum? (2)
4. S_1 and S_2 are sources of coherent waves. An interference pattern is produced between points X and Y. (2)

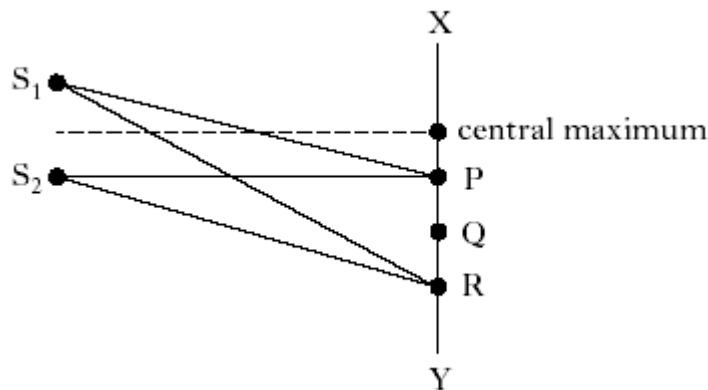

- The first order minimum occurs at P, where $S_1P = 200\text{mm}$ and $S_2P = 180\text{mm}$. Calculate the path difference ($S_1R - S_2R$) for the third order minimum. (2)

Particles and Waves Homework Eight

1. Light of wavelength 540nm is passed through a diffraction grating with a slit separation of 2.5×10^{-6} m.

- Calculate the angle between the zero and first order maxima.
- What is the colour of the light used in this experiment?

(3)

2. When white light is passed through a grating, explain why the central fringe of the interference pattern is white and a series of visible spectra are produced.

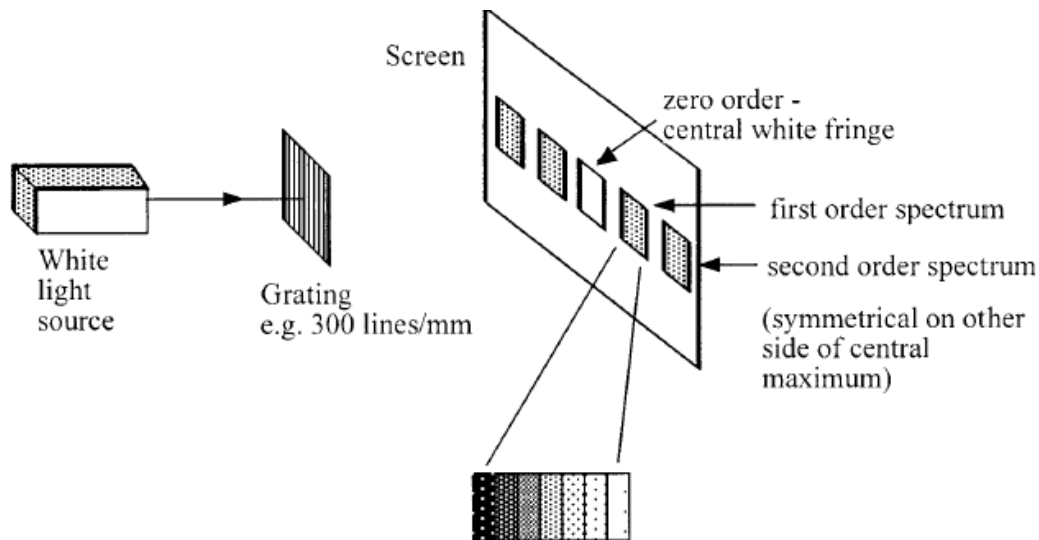

Each fringe appears as a visible spectrum.

(3)

3. White light, with a range of wavelengths from 400nm to 700nm, is passed through a grating with a slit separation of 2.0×10^{-6} m. Calculate the angle between the extremes of the 2nd order maximum.

(4)

Particles and Waves Homework Nine

1. Sketch a graph (no numerical values needed) to illustrate the relationship between the incident angle, θ_1 and the refracted angle, θ_2 when light travels from air into glass.

(1)

2. A ray of light of wavelength 540nm, passes from air into glass ($n = 1.36$). If the incident angle is 40° , calculate:

- The angle of refraction.
- The speed and wavelength in the glass.
- The frequency of the light in air.

(8)

3. The critical angle for a well cut diamond is 24° . What is the refractive index of the diamond? (2)

4. Spectra can be produced by passing white light through a prism or a grating. List the difference between the spectra that are produced. (4)

Particles and Waves Homework Ten

1. Use all the data in the table below to establish the relationship between irradiance and distance

Distance (m)	1.09	0.91	0.71	0.48
Irradiance (Wm^{-2})	0.10	0.14	0.23	0.51

(3)

2. A student measures the irradiance of light 3m from a lamp as 9Wm^{-2} . What will be the irradiance measured at 5m? (2)

3. Photoelectric emission can be investigated using the following apparatus.

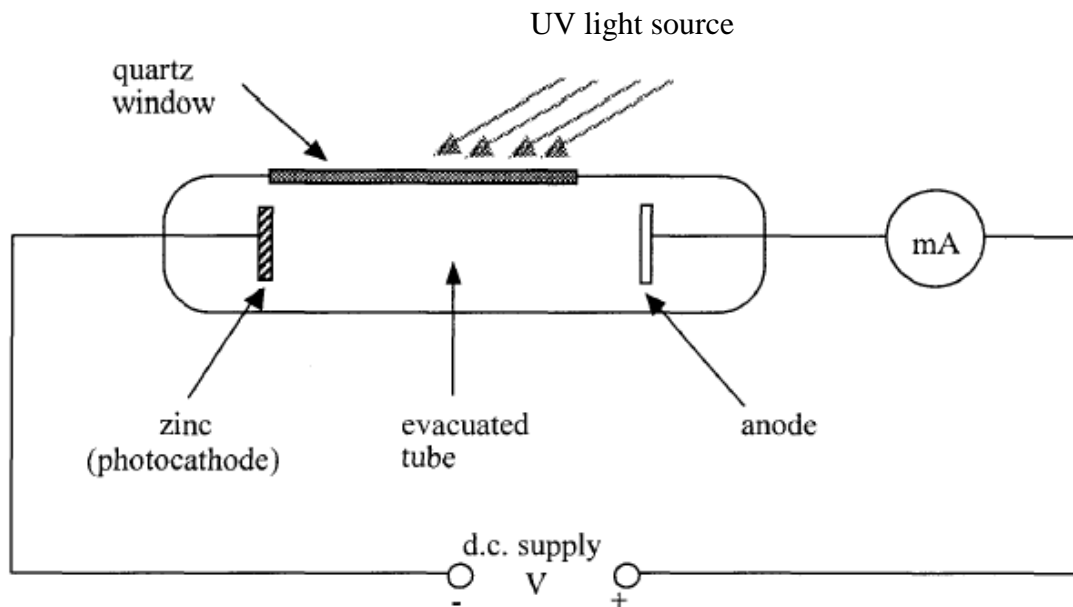

State what will happen to the reading on the milliammeter for each of the following changes:

- More intense UV light is used.
- Less intense UV light is used.
- White light replaces the UV light source.

(3)

4. Copy and complete the following by inserting the correct Physics terms at A and B.
“To explain the _____A_____ effect, light can be considered as consisting of tiny bundles of energy. These bundles of energy are called _____B_____.”

(2)

Particles and Waves Homework Eleven

1. Photons of energy $7.0 \times 10^{-19}\text{J}$ are incident on a clean metal surface. The work function of the metal is $9.0 \times 10^{-19}\text{J}$.

- What is meant by the term *work function*?
- Calculate the threshold frequency of the metal.

(3)

2. Electromagnet radiation of wavelength 523nm is shone on a clean metal plate as shown below.



This releases photoelectrons from the surface of the metal with a maximum kinetic energy of $6.0 \times 10^{-20}\text{J}$.

Calculate:

- the energy of the electromagnetic radiation.

(3)

- the work function of the metal.

(2)

The irradiance of the electromagnetic radiation is increased.

- Will the kinetic energy of the photoelectrons increase, decrease or stay the same?
Explain your answer.

(2)

Particles and Waves Homework Twelve

1. The diagram below represents some of the electron transitions between energy levels in an atom.

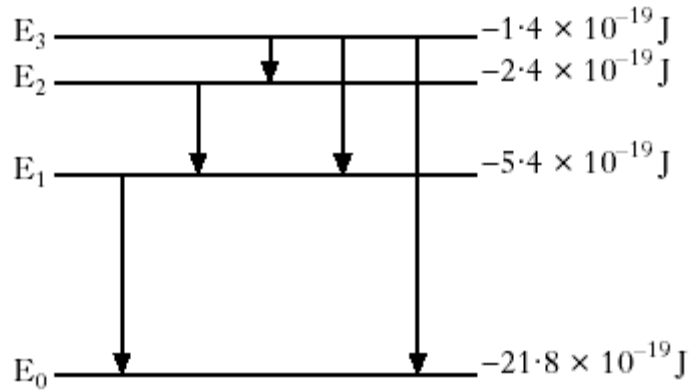

- a) Copy the above diagram and add the missing transition that could cause an emission of radiation. (1)
- b) What is the name given to, E_0 , the lowest energy level for the atom? (1)
- c) Which transition would give the longest wavelength of emitted radiation? (1)
- d) Calculate the frequency of radiation emitted when an electron transits from E_2 to E_1 . (2)
- e) Is the radiation emitted in part d) part of the visible spectrum?
Explain your answer. (2)
- f) What wavelength of radiation would be needed to excite an electron from E_0 to E_1 ? (3)