

**Airdrie Academy
Physics Department**

**Revised Higher
Unit 3 Electricity**



**Problem
Booklet**

Exercise 1: Monitoring and measuring a.c.

1. (a) What is the peak voltage of the 230 V mains supply?
 (b) The frequency of the mains supply is 50 Hz. How many times does the voltage fall to zero in 1 second?

2. The circuit below is used to compare a.c. and d.c. supplies.

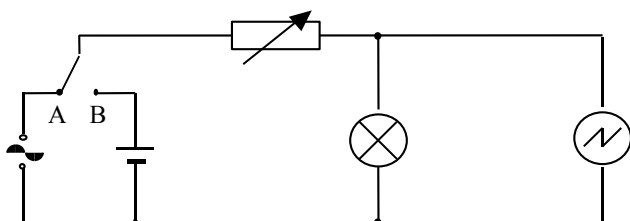

The variable resistor is used to adjust the brightness of the lamp until the lamp has the same brightness when connected to either supply.

- (a) Explain why the brightness of the lamp changes when the setting on the variable resistor is altered.
- (b) What additional apparatus would you use to ensure the brightness of the lamp is the same when connected to either supply?
- (c) The time-base of the oscilloscope is switched off. Diagram 1 shows the oscilloscope trace obtained when the switch is in position B. Diagram 2 shows the oscilloscope trace obtained when the switch is in position A.

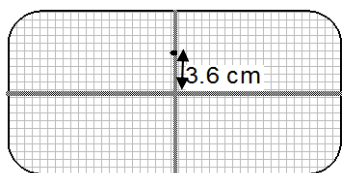

Diagram1

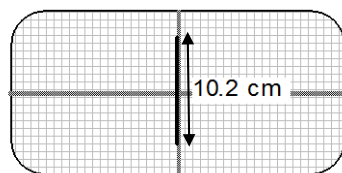

Diagram2

Y gain set to 1 V cm^{-1}

Using information from the oscilloscope traces, find the relationship between the root mean square (r.m.s.) voltage and the peak voltage of a voltage supply.

- (d) The time-base of the oscilloscope is now switched on. Redraw diagrams 1 and 2 to show what happens to the traces.

3. The root mean square voltage produced by a low voltage power supply is 10 V.
- Calculate the peak voltage of the supply.
 - An oscilloscope, with its time-base switched off, is connected across the supply. The Y-gain of the oscilloscope is set to 5 V cm^{-1} . Describe the trace seen on the oscilloscope screen.
4. (a) A transformer has a peak output voltage of 12 V. Calculate the r.m.s. value of this voltage.
- (b) An oscilloscope, with the time base switched off, is connected across another a.c. supply. The Y gain of the oscilloscope is set to 20 V cm^{-1} . A vertical line 6 cm high appears on the oscilloscope screen.

Calculate:

- the peak voltage of the input
 - the r.m.s. voltage of the input.
5. An oscilloscope is connected across a signal generator. The time-base switch is set at 2.5 ms cm^{-1} . The diagram shows the trace on the oscilloscope screen.

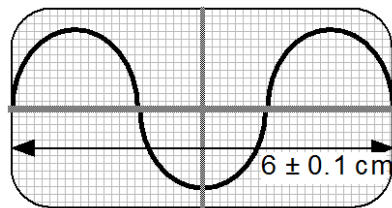

- What is the frequency of the output from the signal generator?
 - What is the uncertainty in the frequency to the nearest Hz?
 - The time base switch is now changed to:
 - 5 ms cm^{-1}
 - 1.25 ms cm^{-1} .
 Sketch the new traces seen on the screen.
6. An a.c. signal of frequency 20 Hz is connected to an oscilloscope. The time-base switch on the oscilloscope is set at 0.01 s cm^{-1} . Calculate the distance between the neighbouring peaks of this waveform when viewed on the screen.

Exercise 2: Current, voltage, power and resistance

1. There is a current of 40 mA in a lamp for 16 s.
Calculate the quantity of charge that passes any point in the circuit in this time.
2. A flash of lightning lasts for 1 ms. The charge transferred between the cloud and the ground in this time is 5 C.
Calculate the value of the average current in this flash of lightning.
3. The current in a circuit is 2.5×10^{-2} A. How long does it take for 500 C of charge to pass any given point in the circuit?
4. There is a current of 3 mA in a 2 k Ω resistor. Calculate the p.d. across the resistor.
5. Calculate the values of the readings on the meters in the following circuits.

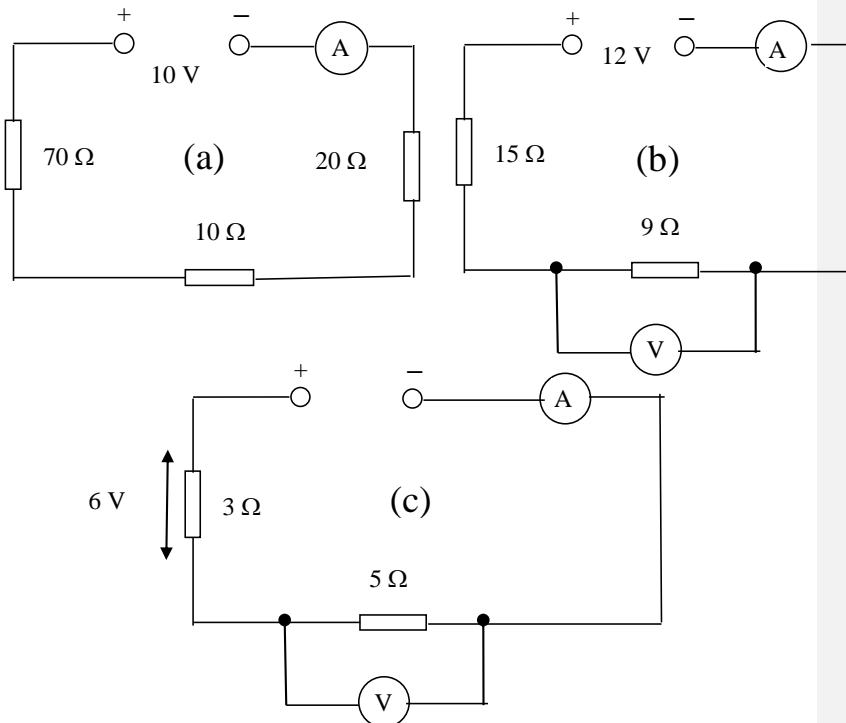

6. Calculate the unknown values R of the resistors in the following circuits.

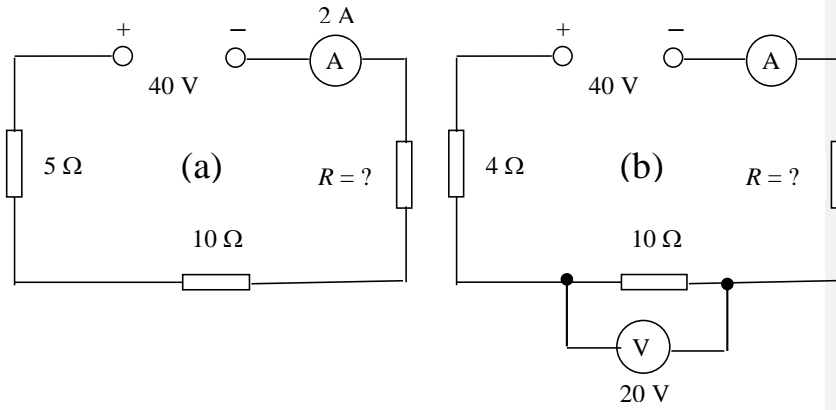

7. Calculate the total resistance between X and Y for the following combinations of resistors.

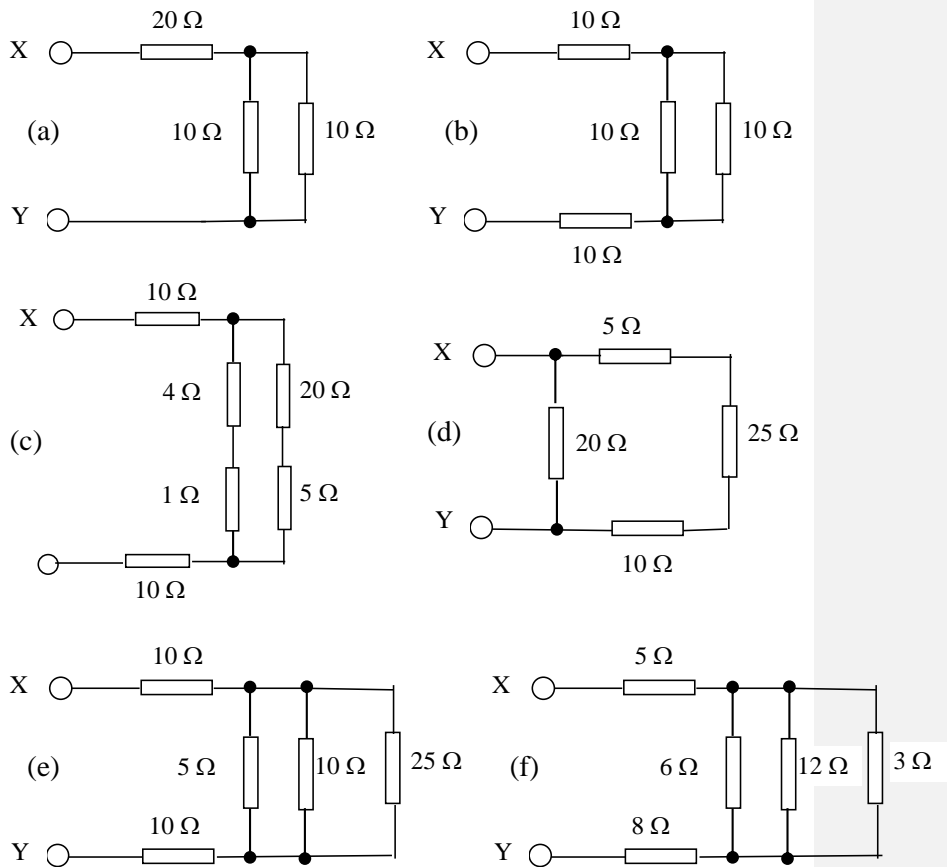

8. In the following circuit the reading on the ammeter is 2 mA. Calculate the reading on the voltmeter.

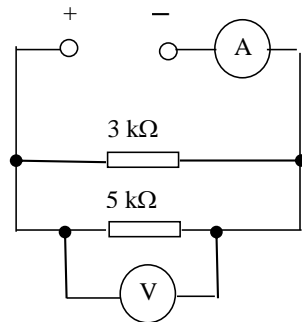

9. Calculate the power in each of the following situations.
- A 12 V battery is connected to a motor. There is a current of 5 A in the motor.
 - A heater of resistance 60Ω connected across a 140 V supply.
 - A current of 5 A in a heater coil of resistance 20Ω .
10. The heating element in an electric kettle has a resistance of 30Ω .
- What is the current in the heating element when it is connected to a 230 V supply?
 - Calculate the power rating of the element in the kettle.
11. A 15 V supply produces a current of 2 A in a lamp for 5 minutes. Calculate the energy supplied in this time.
12. Calculate the readings on the ammeter and the voltmeter in the circuit shown below.

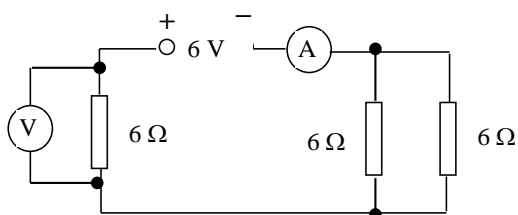

13. Each of the four cells in the circuit shown is identical.

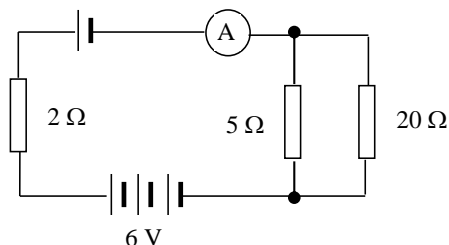

Calculate

- the reading on the ammeter
 - the current in the $20\ \Omega$ resistor
 - the voltage across the $2\ \Omega$ resistor.
14. A voltage of $12\ \text{V}$ is applied across a resistor. The current in the resistor is $50\ \text{mA}$. Calculate the resistance of the resistor.
15. The LED in the circuit below is to emit light.

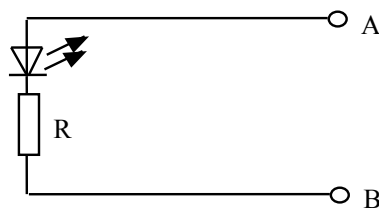

- What is the required polarity of A and B when connected to a $5\ \text{V}$ supply so that the LED emits light?
 - What is the purpose of the resistor R in the circuit?
 - The LED rating is $20\ \text{mA}$ at $1.5\ \text{V}$. Calculate the value of resistor R.
16. Write down the rules which connect the (a) potential differences and (b) the currents in series and parallel circuits.
17. What is the name given to the circuit shown?
Write down the relationship between V_1 , V_2 , R_1 and R_2 .

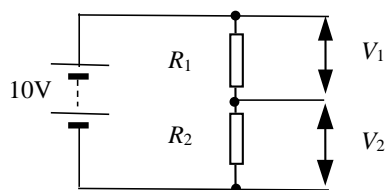

18. Calculate the values of V_1 and V_2 of the circuit in question 17 when:
- $R_1 = 1\ \text{k}\Omega$ $R_2 = 49\ \text{k}\Omega$
 - $R_1 = 5\ \text{k}\Omega$ $R_2 = 15\ \text{k}\Omega$

19. The light dependent resistor in the circuit is in darkness. Light is now shone on the LDR. Explain what happens to the readings on V_1 and V_2 .

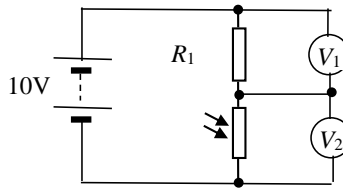

20. Calculate the p.d. across resistor R_2 in each of the following circuits.

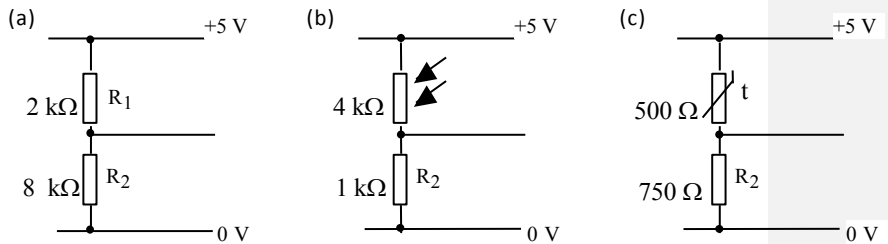

21. Calculate the p.d. across AB (voltmeter reading) in each of the following circuits.

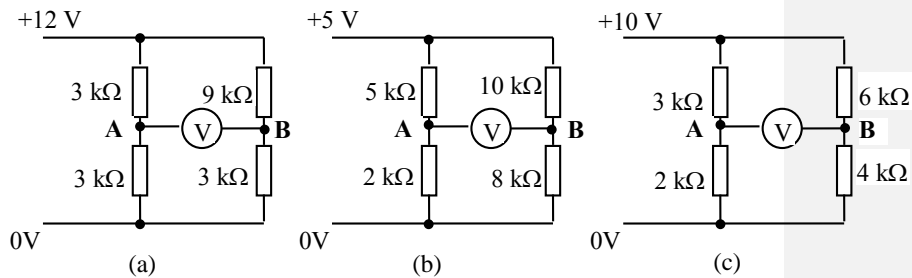

22. A circuit consisting of two potential dividers is set up as shown.

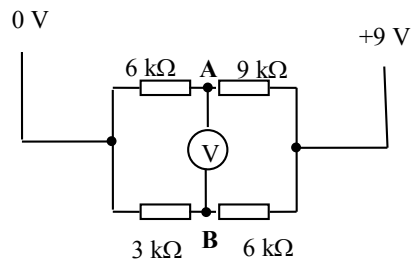

- (a) Calculate the reading on the voltmeter.
 (b) (i) Suggest a value of a resistor to replace the 9 kΩ resistor that would give a reading of 0 V on the voltmeter.
 (ii) Suggest a value of resistor to replace the 3 kΩ resistor that would give a reading of 0 V on the voltmeter.

23. In the circuits shown the reading on the voltmeters is zero. Calculate the value of the unknown resistors X and Y in each of the circuits.

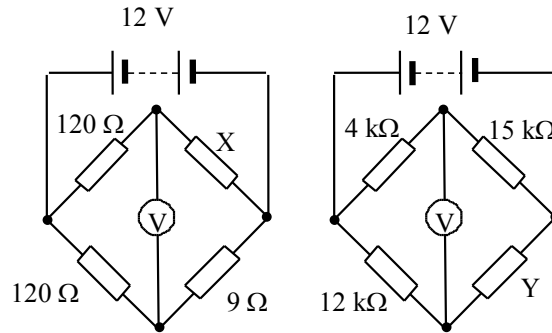

Exercise 3: Electrical sources and internal resistance

- State what is meant by:
 - the e.m.f. of a cell
 - the p.d. between two points in a circuit.

- A circuit is set up as shown.

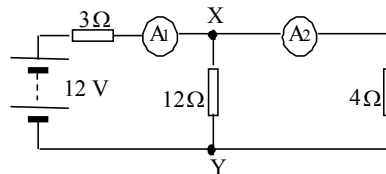

- Calculate the total resistance of the circuit.
 - Calculate the readings on the ammeters.
 - What is the value of the p.d. between X and Y?
 - Calculate the power supplied by the battery.
- The circuit shown uses a 230 V alternating mains supply.

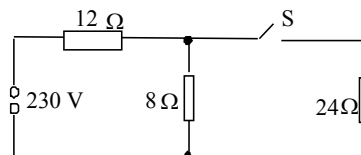

Calculate the current in each resistor when:

- switch S is open
- switch S is closed.

4. An electric cooker has two settings, high and low. This involves two heating elements, R_1 and R_2 . On the low setting the current from the supply is 1 A. On the high setting the current from the supply is 3 A.

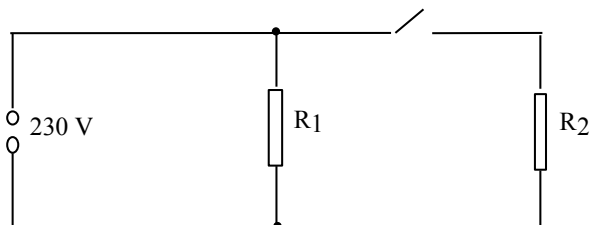

- (a) Calculate the resistance of R_1 and R_2 .
 (b) What is the power consumption at each setting?
5. A lamp is rated at 12 V, 36 W. It is connected in a circuit as shown.

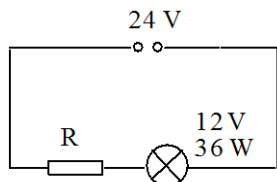

- (a) Calculate the value of the resistor R that allows the lamp to operate at its normal rating.
 (b) Calculate the power dissipated in the resistor.
6. In the circuit shown, r represents the internal resistance of the cell and R represents the external resistance (or load resistance) of the circuit.

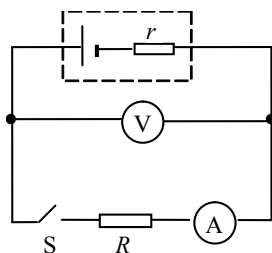

When S is open, the reading on the voltmeter is 2.0 V.
 When S is closed, the reading on the voltmeter is 1.6 V and the reading on the ammeter is 0.8 A.

- (a) What is the value of the e.m.f. of the cell?
 (b) When S is closed what is the terminal potential difference across the cell?
 (c) Calculate the values of r and R .
 (d) The resistance R is now halved in value. Calculate the new readings on the ammeter and voltmeter.

7. The battery in the circuit shown has an e.m.f. of 5.0 V.

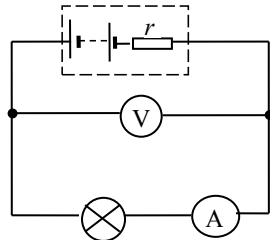

The current in the lamp is 0.20 A and the reading on the voltmeter is 3.0 V. Calculate the internal resistance of the battery.

8. A battery of e.m.f. 4.0 V is connected to a load resistor with a resistance of $15\ \Omega$. There is a current of 0.2 A in the load resistor. Calculate the internal resistance of the battery.
9. A signal generator has an e.m.f. of 8.0 V and an internal resistance of $4.0\ \Omega$. A load resistor is connected across the terminals of the generator. The current in the load resistor is 0.50 A. Calculate the resistance of the load resistor.
10. A cell is connected in a circuit as shown below.

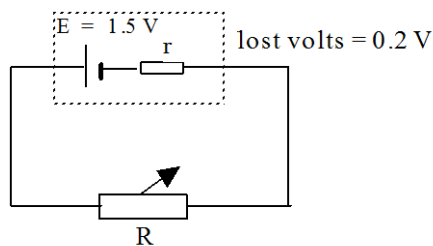

- (a) Calculate the terminal p.d. across the cell.
- (b) The resistance of the variable resistor R is now increased.
- (i) Describe *and* explain what happens to the current in the circuit.
- (ii) Describe *and* explain what happens to the p.d. across the terminals of the cell.
11. A cell has an e.m.f. 1.5 V and an internal resistance of $2.0\ \Omega$. A $3.0\ \Omega$ resistor is connected across the terminals of the cell. Calculate the current in the circuit.

12. A student is given a voltmeter and a torch battery. When the voltmeter is connected across the terminals of the battery the reading on the voltmeter is 4.5 V. When the battery is connected across a 6.0Ω resistor the reading on the voltmeter decreases to 3.0 V.
- (a) Calculate the internal resistance of the battery.
 (b) What value of resistor when connected across the battery reduces the reading on the voltmeter to 2.5 V?

13. In the circuit shown, the battery has an e.m.f. of 6.0 V and an internal resistance of 1.0Ω .

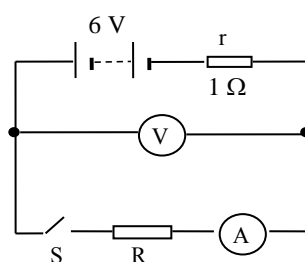

When the switch is closed, the reading on the ammeter is 2.0 A. What is the corresponding reading on the voltmeter?

14. To find the internal resistance of a cell a load resistor is connected across the terminals of the cell. A voltmeter is used to measure $V_{t.p.d.}$, the voltage measured across the terminals of the cell. An ammeter is used to measure I , the current in the variable resistor. The table below shows the results obtained as the resistance of the variable resistor is changed.

$V_{t.p.d.}$ (V)	1.02	0.94	0.85	0.78	0.69	0.60
I (A)	0.02	0.04	0.06	0.08	0.10	0.12

- (a) Draw a diagram of the circuit used to produce these results.
 (b) Plot a graph of the results and from it determine:
 (i) the e.m.f. of the cell
 (ii) the internal resistance of the cell
 (iii) the short circuit current of the cell.

15. A variable resistor is connected across a power supply. A voltmeter is used to measure $V_{t.p.d.}$, the voltage measured across the terminals of the supply. An ammeter is used to measure I , the current in the variable resistor. The table below shows the results obtained as the resistance of the variable resistor is changed.

$V_{t.p.d.}$ (V)	5.5	5.6	5.7	5.8	5.9
I (A)	5.0	4.0	3.0	2.0	1.0

Plot a graph of $V_{t.p.d.}$ against I .

- What is the value of the open circuit p.d.?
- Calculate the internal resistance of the power supply.
- Calculate the short circuit current of the power supply.
- The variable resistor is now removed from the circuit and a lamp of resistance 1.5Ω is connected across the terminals of the supply.

Calculate:

- the terminal p.d.
- the power delivered to the lamp.

16. A circuit is set up as shown to investigate the properties of a battery.

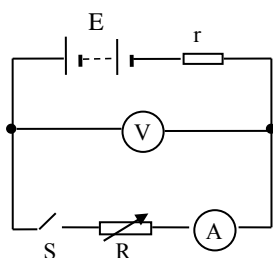

The variable resistor provides known values of resistance R .

For each value of resistance R , the switch is closed and the current I noted.

The table shows the results obtained.

R (Ω)	0	2	4	6	8	10	12
I (A)	6.80	3.78	2.62	2.00	1.62	1.36	1.17
$1/I$ (A^{-1})							

- (a) Show that the relationship $E = I(R + r)$ can be put in the form:

$$R = \frac{E}{I} - r$$

- (b) Complete the third row in the table.
- (c) Use the values of R and $1/I$ to plot a graph.
- (d) Use the information in the graph to find:
 (i) the internal resistance of the battery
 (ii) the e.m.f. of the battery.
- (e) The battery is now short circuited. Calculate the current in the battery when this happens.
17. A student uses the following circuit to investigate the conditions for transferring the maximum power into a load resistor.

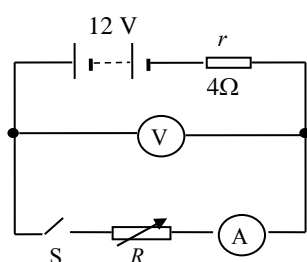

For each setting of the variable resistor the current in the circuit is recorded.

The table below shows the results obtained.

R (Ω)	1	2	3	4	5	6
I (A)	2.40	2.00	1.71	1.50	1.33	1.20
Power in R (W)						

- (a) Complete the table by calculating the power in the load for each value of R .
- (b) Sketch a graph to show how the power in the load resistor R varies with R .
- (c) In order to achieve maximum transfer of power, what is the relationship between the internal resistance of the power source and the resistance of the load resistor?

18. An automotive electrician needed to accurately measure the resistance of a resistor. She set up a circuit using an analogue milliammeter and a digital voltmeter.

The two meter readings were as shown in the diagram below.

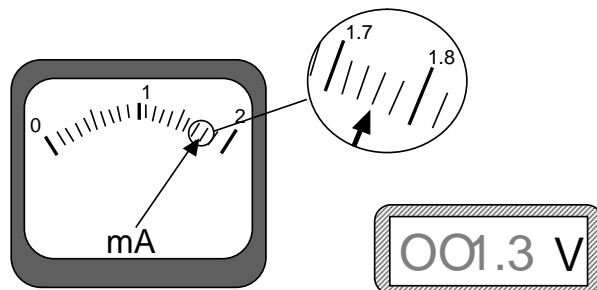

- What are the readings on the ammeter and the voltmeter?
- What is the nominal resistance calculated from these readings
- What is the smallest division on the milliammeter?
- What is the absolute uncertainty on the milliammeter?
- What is the absolute uncertainty on the voltmeter?
- What is the percentage uncertainty on the milliammeter?
- What is the percentage uncertainty on the voltmeter?
- Which is the greatest percentage uncertainty?
- What is the percentage uncertainty in the resistance?
- What is the absolute uncertainty in the resistance?
- Express the final result as (resistance \pm uncertainty) Ω
- Round both the result and the uncertainty to the relevant number of significant figures or decimal places.

Exercise 4: Capacitors

1. A $50\ \mu\text{F}$ capacitor is charged until the p.d. across it is $100\ \text{V}$.
 - (a) Calculate the charge on the capacitor when the p.d. across it is $100\ \text{V}$.
 - (b) (i) The capacitor is now 'fully' discharged in a time of 4.0 milliseconds. Calculate the average current during this time.
(ii) Why is this average current?
2. A capacitor stores a charge of $3.0 \times 10^{-4}\ \text{C}$ when the p.d. across its terminals is $600\ \text{V}$.
What is the capacitance of the capacitor?
3. A $30\ \mu\text{F}$ capacitor stores a charge of $12 \times 10^{-4}\ \text{C}$.
 - (a) What is the p.d. across its terminals?
 - (b) The tolerance of the capacitor is $\pm 0.5\ \mu\text{F}$. Express this uncertainty as a percentage.
4. A $15\ \mu\text{F}$ capacitor is charged using a $1.5\ \text{V}$ battery.
Calculate the charge stored on the capacitor when it is fully charged.
5. (a) A capacitor stores a charge of $1.2 \times 10^{-5}\ \text{C}$ when there is a p.d. of $12\ \text{V}$ across it. Calculate the capacitance of the capacitor.
(b) A $0.10\ \mu\text{F}$ capacitor is connected to an $8.0\ \text{V}$ d.c. supply. Calculate the charge stored on the capacitor when it is fully charged.
6. A circuit is set up as shown.

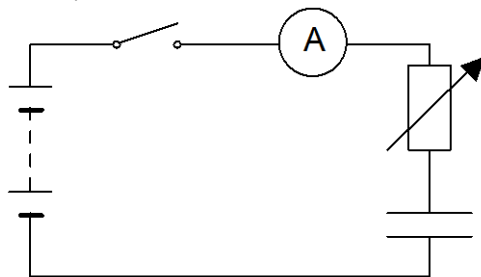

The capacitor is initially uncharged. The switch is now closed.
The capacitor is charged with a constant charging current of $2.0 \times 10^{-5}\ \text{A}$ for $30\ \text{s}$.

At the end of this time the p.d. across the capacitor is $12\ \text{V}$.

- (a) What has to be done to the value of the variable resistor in order to keep the current constant for $20\ \text{s}$?
- (b) Calculate the capacitance of the capacitor.

7. A $100\ \mu\text{F}$ capacitor is charged using a $20\ \text{V}$ supply.
- How much charge is stored on the capacitor when it is fully charged?
 - Calculate the energy is stored in the capacitor when it is fully charged.
8. A $30\ \mu\text{F}$ capacitor stores $6.0 \times 10^{-3}\ \text{C}$ of charge. How much energy is stored in the capacitor?
8. The circuit below is used to investigate the charging of a capacitor.

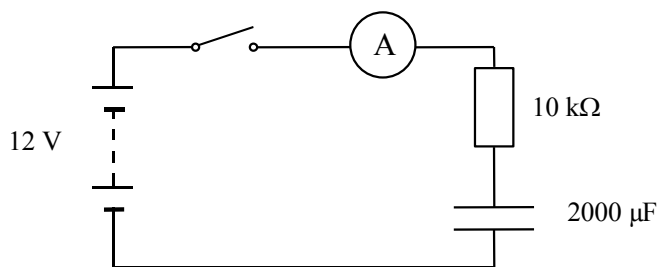

The battery has negligible internal resistance.
The capacitor is initially uncharged. The switch is now closed.

- Describe what happens to the reading on the ammeter from the instant the switch is closed.
 - How can you tell when the capacitor is fully charged?
 - What would be a suitable range for the ammeter?
 - The $10\ \text{k}\Omega$ resistor is now replaced by a larger resistor and the investigation repeated.
What is the maximum voltage across the capacitor now?
9. In the circuit below the neon lamp flashes at regular intervals.

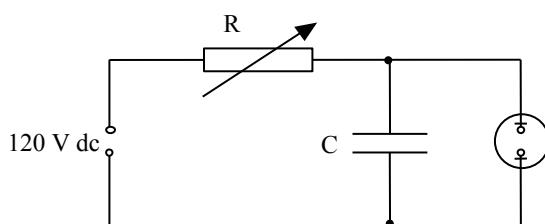

The neon lamp requires a potential difference of $100\ \text{V}$ across it before it conducts and flashes. It continues to glow until the potential difference across it drops to $80\ \text{V}$. While lit, its resistance is very small compared with the resistance of R .

- Explain why the neon bulb flashes.
- Suggest two methods of decreasing the flash rate.

10. In the circuit below the capacitor C is initially uncharged.

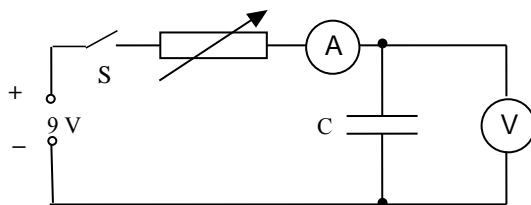

Switch S is now closed. By carefully adjusting the variable resistor R a constant charging current of 1.0 mA is maintained. The reading on the voltmeter is recorded every 10 seconds. The results are shown in the table below.

Time (s)	0	10	20	30	40
V (V)	0	1.9	4.0	6.2	8.1

- Plot a graph of the charge on the capacitor against the p.d. across the capacitor.
- Use the graph to calculate the capacitance of the capacitor.

11. The circuit below is used to charge and discharge a capacitor.

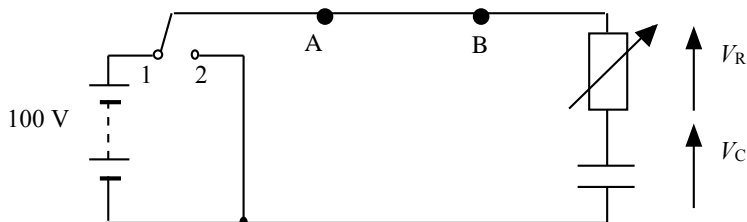

The battery has negligible internal resistance. The capacitor is initially uncharged. V_R is the p.d. across the resistor and V_C is the p.d. across the capacitor.

- What is the position of the switch:
 - to charge the capacitor
 - to discharge the capacitor?
- Sketch graphs of V_R against time for the capacitor charging and discharging. Show numerical values for the maximum and minimum values of V_R .

- (c) Sketch graphs of V_C against time for the capacitor charging and discharging. Show numerical values for the maximum and minimum values of V_C .
- (d) (i) When the capacitor is charging what is the direction of the electrons between points A and B in the wire?
(ii) When the capacitor is discharging what is the direction of the electrons between points A and B in the wire?
- (e) The capacitor has a capacitance of $4.0 \mu\text{F}$. The resistor has resistance of $2.5 \text{ M}\Omega$.

Calculate:

- (i) the maximum value of the charging current
(ii) the charge stored by the capacitor when the capacitor is fully charged.

12. A capacitor is connected in a circuit as shown.

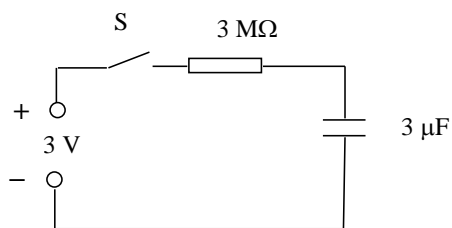

The power supply has negligible internal resistance. The capacitor is initially uncharged. V_R is the p.d. across the resistor and V_C is the p.d. across the capacitor. The switch S is now closed.

- (a) Sketch graphs of:
(i) V_C against time during charging. Show numerical values for the maximum and minimum values of V_C .
(ii) V_R against time during charging. Show numerical values for the maximum and minimum values of V_R .
- (b) (i) What is the p.d. across the capacitor when it is fully charged?
(ii) Calculate the charge stored by the capacitor when it is fully charged.
- (c) Calculate the maximum energy stored by the capacitor.

13. A capacitor is connected in a circuit as shown.

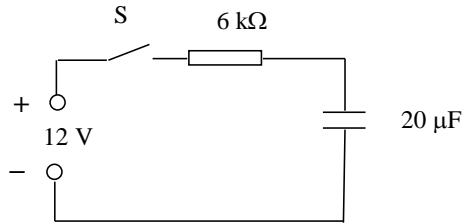

The power supply has negligible internal resistance.
The capacitor is initially uncharged. The switch S is now closed.

- (a) Calculate the value of the initial current in the circuit.
(b) At a certain instant in time during charging the p.d. across the capacitor is 3 V . Calculate the current in the resistor at this time.

14. The circuit shown is used to charge a capacitor.

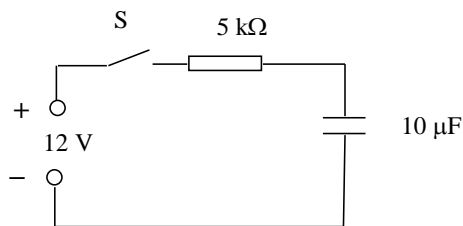

The power supply has negligible internal resistance.
The capacitor is initially uncharged. The switch S is now closed.
At a certain instant in time the charge on the capacitor is $20\ \mu\text{C}$.
Calculate the current in the circuit at this time.

15. The circuit shown is used to investigate the charge and discharge of a capacitor.

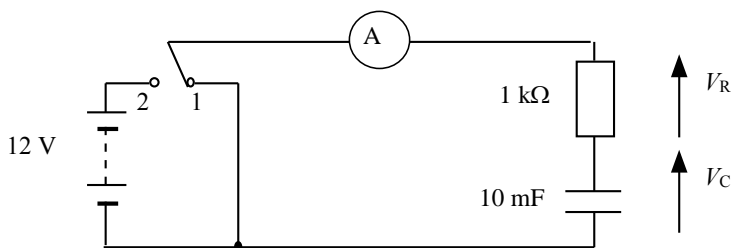

The switch is in position 1 and the capacitor is uncharged.
The switch is now moved to position 2 and the capacitor charges.
The graphs show how V_C , the p.d. across the capacitor, V_R , the p.d. across the resistor, and I , the current in the circuit, vary with time.

V_C versus time

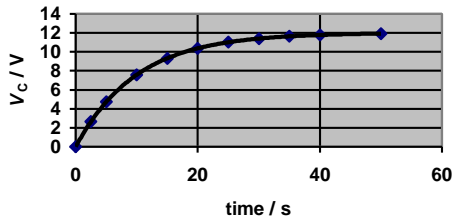

V_R versus time

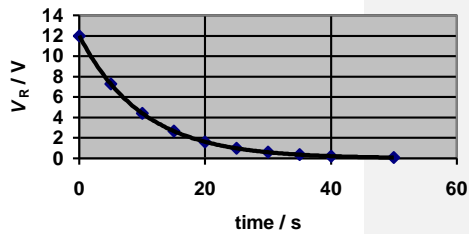

Current versus time

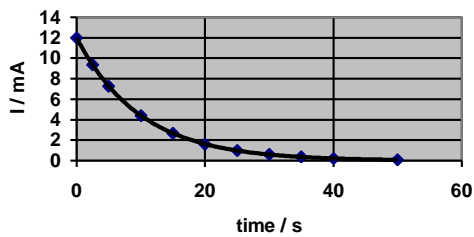

- The experiment is repeated with the resistance changed to $2\text{ k}\Omega$. Sketch the graphs above and on each graph sketch the new lines which show how V_C , V_R and I vary with time.
- The experiment is repeated with the resistance again at $1\text{ k}\Omega$ but the capacitor replaced with one of capacitance 20 mF . Sketch the original graphs again and on each graph sketch the new lines which show how V_C , V_R and I vary with time.
- What does the area under the current against time graph represent?
 - Compare the areas under the current versus time graphs in the original graphs and in your answers to (a) and (b). Give reasons for any differences in these areas.
- At any instant in time during the charging what should be the value of $(V_C + V_R)$?
- The original values of resistance and capacitance are now used again and the capacitor fully charged. The switch is now moved to position 1 and the capacitor discharges. Sketch graphs of V_C , V_R and I from the instant the switch is moved until the capacitor is fully discharged.

16. A student uses the circuit shown to investigate the charging of a capacitor.

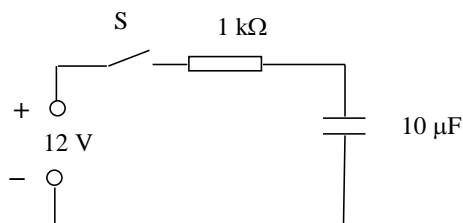

The capacitor is initially uncharged.

The student makes the following statements:

- (a) When switch S is closed the initial current in the circuit does not depend on the internal resistance of the power supply.
- (b) When the capacitor has been fully charged the p.d. across the capacitor does not depend on the internal resistance of the power supply.

Use your knowledge of capacitors to comment on the truth or otherwise of these two statements.

Exercise 5: Electrons at work

1. In the following descriptions of energy levels in metals, insulators and semiconductors some words and phrases have been replaced by the letters A to N.

In a metal the ___A___ band is completely filled and the ___B___ band is partially filled. The electrons in the ___C___ band are free to move under the action of ___D___ so the metal has a ___E___ conductivity.

In an insulator there are no free electrons in the ___F___ band. The energy gap between the two bands is large and there is not enough energy at room temperature to move electrons from the ___G___ band into the ___H___ band.

Insulators have a very ___I___ conductivity.

In a pure semiconductor the energy gap between the valence and conduction bands is ___J___ than in a metal. At room temperature there is enough energy to move some electrons from the ___K___ band into the ___L___ band. As the temperature is increased the

number of electrons in the conduction band ____ **M** ____ so the conductivity of the semiconductor ____ **N** ____.

From the table below choose the correct words or phrases to replace the letters.

Letter	List of replacement word or phrase
A, B, C, F, G, H, K, L	conduction, valence
D	an electric field, a magnetic field
E, I	low, high
J	bigger, smaller
M, N	decreases, increases

2. The conductivity of a semiconductor material can be increased by 'doping'.
 - (a) Explain what is meant by the 'conductivity' of a material.
 - (b) Explain, giving an example, what is meant by 'doping' a semiconductor.
 - (c) Why does 'doping' decrease the resistance of a semiconductor material?
3.
 - (a) A sample of pure germanium (four electrons in the outer shell) is doped with phosphorus (five electrons in the outer shell). What kind of semiconductor is formed?
 - (b) Why does a sample of n-type semiconductor still have a neutral overall charge?
4. Describe the movement of the majority charge carriers when a current flows in:
 - (a) an n-type semiconductor material
 - (b) a p-type semiconductor material.
5. A p-n junction diode is connected across a d.c. supply as shown.

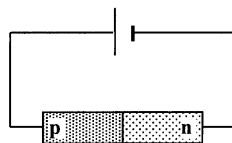

- (a) Is the diode connected in forward or reverse bias mode?
- (b) Describe the movement of the majority charge carriers across the p-n junction.
- (c) What kind of charge is the only one that actually moves across the junction?

6. When positive and negative charge carriers recombine at the junction of ordinary diodes and LEDs, quanta of radiation are emitted from the junction.
- Does the junction have to be forward biased or reverse biased for radiation to be emitted?
 - What form does this emitted energy take when emitted by:
 - an LED
 - an ordinary junction diode?
7. A particular LED is measured as having a recombination energy of 3.12×10^{-19} J.
- Calculate the wavelength of the light emitted by the LED.
 - What colour of light is emitted by the LED?
 - What factor about the construction of the LED determines the colour of the emitted light?
8. (a) State two advantages of an LED over an ordinary filament lamp.
 (b) An LED is rated as follows: operating p.d. 1.8 V, forward current 20 mA

The LED is to be operated from a 6 V d.c. power supply.

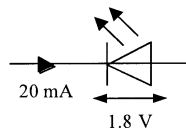

- Draw a diagram of the circuit, including a protective resistor, which allows the LED to operate at its rated voltage.
 - Calculate the resistance of the protective resistor that allows the LED to operate at its rated voltage.
9. The diagram shows a photodiode connected to a voltmeter.

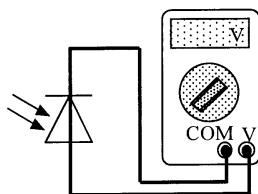

- In which mode is the photodiode operating?
- Light is now incident on the photodiode.
 - Explain how an e.m.f. is created across the photodiode.

- (ii) The irradiance of the light incident on the photodiode is now increased. Explain why this increases the e.m.f. of the photodiode.

10. A photodiode is connected in reverse bias in a series circuit as shown.

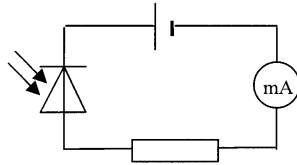

- (a) In which mode is the photodiode is operating?
(b) Why is the photodiode connected in reverse bias?
(c) What is the current in the circuit when the photodiode is in darkness? Explain your answer.
(d) The irradiance of the light on the photodiode is now increased.
(i) What is the effect on the current in the circuit?
(ii) What happens to the effective 'resistance' of the photodiode? Explain why this happens.

Solutions

Exercise 1: Monitoring and measuring a.c.

- (a) 325 V
(b) 100 times
- (c) $V_{\text{r.m.s.}} = 0.71 V_{\text{peak}}$
- (a) 14 V
- (a) 8.5 V
(b) (i) 60 V
(ii) 42 V
- (a) (i) 100 Hz
(ii) ± 2 Hz
- 5 cm

Exercise 2: Current, voltage, power and resistance

- 0.64 C
- 5×10^3 A
- 2.0×10^4 s
- 6 V
- (a) $I = 0.1$ A
(b) $I = 0.5$ A, $V = 4.5$ V
(c) $I = 2$ A, $V = 10$ V
- (a) 5 Ω
(b) 6 Ω
- (a) 25 Ω
(b) 25 Ω
(c) 24.2 Ω
(d) 13.3 Ω
(e) 22.9 Ω
(f) 14.7 Ω
- 3.75×10^{-3} V
- (a) 60 W
(b) 327 W
(c) 500 W
- (a) 7.7 A (b) 1763 W

11. 9000 J
12. $I = 0.67 \text{ A}$, $V = 4 \text{ V}$
13. (a) 0.67 A
(b) 0.13 A
(c) 1.34 V
14. 240 Ω
15. (c) 175 Ω
18. (a) $V_1 = 0.2 \text{ V}$, $V_2 = 9.8 \text{ V}$
(b) $V_1 = 2.5 \text{ V}$, $V_2 = 7.5 \text{ V}$
20. (a) 4 V
(b) 1 V
(c) 3 V
21. (a) 3 V
(b) -0.8 V
(c) 0 V
22. (a) 0.6 V
(b) (i) 12 k Ω
(ii) 4 k Ω
23. $X = 9 \text{ } \Omega$ $Y = 45 \text{ } \Omega$

Exercise 3: Electrical sources and internal resistance

2. (a) 6 Ω
(b) $A_1 = 2 \text{ A}$, $A_2 = 1.5 \text{ A}$
(c) 6 V
(d) 24 W
3. (a) In 12 Ω current is 11.5 A; in 24 Ω current is 0 A
(b) In 12 Ω current is 12.8 A; in 8 Ω current is 3.2 A; in 24 Ω current is 9.6 A
4. (a) $R_1 = 230 \text{ } \Omega$ $R_2 = 115 \text{ } \Omega$
(b) Low 230 Ω high 690 Ω
5. (a) 4 Ω
(b) 36 W
6. (a) 2.0 V
(b) 1.6 V
(c) $r = 0.5 \text{ } \Omega$ $R = 2 \text{ } \Omega$
(d) 1.3 A, 1.3 V
7. 10 Ω

Commented [ANG1]: Answer for 8 Ω ?

Commented [jp2]: --12 Ω and 8 Ω --

8. 5Ω
9. 12Ω
10. (a) 1.3 V
11. 0.30 A
12. (a) 3.0Ω
(b) 3.75Ω
13. 4.0 V
14. (b) (i) 1.1 V , the intercept on the y -axis
(ii) 4.2Ω the gradient of the line
(iii) 0.26 A
15. (a) 6 V
(b) 0.1Ω
(c) 60 A
(d) (i) 5.6 V
(ii) 21 W
16. (b) $0.147, 0.264, 0.382, 0.500, 0.617, 0.735, 0.855$
(d) (i) 2.5Ω
(ii) 17 V
(e) 6.8 A
18. (a) Ammeter 1.76 mA , voltmeter 1.3 V
(b) 740Ω
(c) 0.02 mA
(d) $\pm 0.01 \text{ mA}$
(e) $\pm 0.1 \text{ V}$
(f) 0.6%
(g) 8%
(h) 8%
(i) 8%
(j) 59%
(k) $(740 \pm 59) \Omega$
(l) $(740 \pm 60) \Omega$

Exercise 4: Capacitors

1. (a) $5.0 \times 10^{-3} \text{ C}$
(b) (i) 1.25 A
2. $0.5 \mu\text{F}$
3. (a) 40 V (b) 1.7%

4. $2.25 \times 10^{-5} \text{ C}$
5. (a) $1.0 \mu\text{F}$
(b) $0.8 \mu\text{C}$
6. (b) $50 \mu\text{F}$
7. (a) $2.0 \times 10^{-3} \text{ C}$
(b) 0.020 J
8. 0.60 J
9. (b) Reading on ammeter is 0 A
(c) $0 \text{ to } 2 \text{ mA}$ (max. current 1.2 mA)
(d) 12 V
10. (b) 4.9 mF
11. (e) (i) $40 \mu\text{A}$
(ii) $4.0 \times 10^2 \mu\text{C}$
12. (b) (i) 3 V
(ii) $9 \mu\text{C}$
(c) $1.35 \times 10^{-5} \text{ J}$
13. (a) 2 mA
(b) 1.5 mA
14. 2 mA

Exercise 5: Electrons at work

1. A = valence; B = conduction; C = conduction; D = an electric field; E = high; F = conduction; G = valence; H = conduction; I = low; J = smaller; K = valence; L = conduction; M = increases; N = increases.
7. (a) 638 nm
(b) Red
8. (b) (ii) 210Ω