

TeeJay Publishers

5-14 Mathematics
5-14 Mathematics
5-14 Mathematics



Level E Textbook

a cornerstone in Scottish Education

IMPORTANT

This is an Accessible Digital Copy of a printed book. The original digital file from which the Accessible Copy was made was kindly provided by the publishers. All rights to the Accessible digital copy are retained by the rightsholders of the printed books.

This Accessible Digital Copy is for the personal use of an “**Authorised Person**” who is defined as “**a pupil who is visually impaired or otherwise disabled and by reason of such visual impairment or disability is unable to read or access the original printed book**”.

An Authorised Person is regarded as “visually impaired” in accordance with s.31F (9) of the Copyright, Designs and Patents Act 1988, or, as appropriate, as a “disabled person” in accordance with s.1 of the Disability Discrimination Act 1995.

No other pupils can use the Copies.

The Accessible Copy may be stored on the students’ personal computer or other electronic device, or on a secure password-protected intranet limiting access to the student(s) only.

The user(s) of the Accessible Digital Copy must have legal access to a hard copy of the book, bought either for personal use or as part of a class set.

If the pupil(s) cannot access the Accessible Digital Copy, it may be converted into another Alternative Format. The book may not be altered except as required for conversion to the Alternative Format, and conversion must retain the integrity of the text.

The student(s) may print the contents of the book for personal use only.

The Accessible Copy **may not** be further copied, nor may it be supplied to any other person, without permission. It **may not** be made available on the world wide web or copied or transferred to any third party.

The Accessible Digital Copy should be deleted once the pupil(s) have completed the course for which it was supplied.

Do not supply the Accessible Copy to other pupils. If you require another Accessible Copy of this book for more pupils, you must download another copy from the Books for All Scotland Database.

Please note that that usage of Accessible Digital Copies outwith these terms and conditions may result in legal action against you and/or your educational establishment.

TeeJay Publishers

Level E Textbook

Produced by members of the TeeJay Writing Group

T. Strang (P.T. Mathematics - Clydebank High School)
J. Geddes (P.T. Mathematics - Renfrew High School)

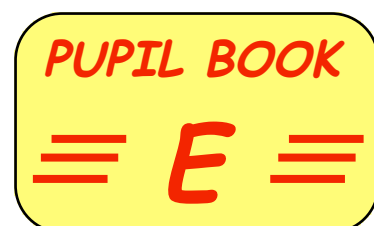

TeeJay Publishers

P.O. Box 1375

Barrhead

Glasgow

G78 1JJ

Tel: 0141 880 6839

Fax: 0870 124 9189

e-mail: teejaypublishers@ntlworld.com

web page: www.teejaypublishers.co.uk

© TeeJay Publishers 2003

Coloured Edition published by TeeJay Publishers - May 2009

All rights in this book are reserved. No part of this book may be copied or reproduced in any format, including electronic, without the express permission of the authors in accordance with the Copyright, Design and Patents Act of 1988.

Any person or organisation who makes unauthorised copies of any part of this book may be liable to prosecution and possible civil claims for damages.

Level E Textbook

The book can be used in both Primary and Secondary with pupils who have gained a Level D.

- ◆ In secondary schools it can be used to condense the S1/2 course into a **ONE** year course for those pupils who had already gained a National Test level D in Primary or early Secondary.
 - It should prepare pupils to sit maths level E national test, **or equivalent**, by the end of S1 or early in S2.
 - There are no A and B exercises. It basically covers the entire Level E course without the teacher having to pick and choose which questions to leave out and which exercises are important. They all are !
 - Unlike other commercial resources out at present or in production, it will cover the important work of level E in ONE textbook.
 - It should prove to be an invaluable aid to the "fast tracking" of pupils in S1/2 and allow them to begin their Credit or Intermediate 2 course at the beginning of S2 or at the latest by Xmas time.
 - It contains an 8 page "Chapter Zero" which primarily revises every topic at level D and can be used as a diagnostic tool. This could be followed by a diagnostic assessment of the work of Level D.
 - Non-calculator skills will be emphasised and encouraged throughout the book
 - Each topic will have a "Topic in a Nutshell" exercise as a summary.
 - Homework will be available as a photocopiable pack along with an Assessment pack which can be used topic by topic or combined to form a series of level E cumulative Tests.

Pupils should then be able to complete their Credit or Intermediate 2 course leisurely by the end of S3 or early in S4. This could allow Unit 1 of Higher Maths to be tackled and assessed before beginning the revision for their Credit or Intermediate 2 May examination.

This might also help eradicate the two term dash needed to complete the Higher course in S5

Tom Strang and Jim Geddes

(June 2003)

Contents

		<i>page</i>
Chapter 0	Quick Revision/Diagnosis of all Level D work	1 - 8
Ch 1 Whole Numbers	Place values	9 - 10
	Addition and subtraction	11 - 12
	Multiplication / division	13 - 18
	Multiplication / division by 10, 100 etc	19 - 20
	Rounding	21 - 22
	Topic in a Nutshell	23 - 24
Ch 2 Decimals	Working with decimals	25 - 27
	Decimal scales	28 - 29
	Rounding to 1 decimal place	30 - 31
	Addition and subtraction	32 - 34
	Multiplication and division	35 - 40
	Topic in a Nutshell	41 - 42
Ch 3 Time	Revising 12 hr \leftrightarrow 24 hr times	43
	Problems involving time calculations	44 - 45
	Timing using a stopwatch	46 - 47
	Topic in a Nutshell	48
Ch 4 Money	Simple money problems	49 - 52
	Foreign exchange	53 - 56
	Topic in a Nutshell	57 - 58
Ch 5 Negative Numbers	Interpreting negative numbers	59 - 60
	Simple "up" and "down" using a thermometer	61 - 62
	Simple adding and subtracting using a thermometer	62 - 63
	Coordinates in all 4 quadrants	63 - 65
	Topic in a Nutshell	66
Ch 6 Fractions/Percentages	What is a fraction	67 - 69
	Simple fractions of a quantity	69 - 70
	Simple equivalence of fractions and percentages	71 - 72
	Simple percentages of a quantity using a calculator	72 - 73
	Simple percentages (using fractions - non calculator)	74 - 76
	Topic in a Nutshell	77 - 78
Ch 7 Symmetry	Revision of line symmetry	79 - 81
	Rotational symmetry and order	82 - 86
	Translation (sliding tiles)	87 - 89
	Topic in a Nutshell	90 - 91
Ch 8 Algebra	Tidying up terms	92
	Number machines	93
	Working with expressions	94 - 95
	Solving equations	96 - 98
	Solving inequalities	98 - 101
	Topic in a Nutshell	102 - 103
Ch 9 Statistics	Average (the mean) and the range	104 - 107
	Organising information - frequency tables	108 - 110
	Line graphs	111 - 112
	Pie charts	113 - 115
	Topic in a Nutshell	116 - 117

Ch 10	Length & Area	Units of length and their usage and perimeter	118 - 122
		Area of a square and rectangle	123 - 127
		Simple composite shapes	128
		Area of a right angled triangle	129 - 130
		Topic in a Nutshell	131
Ch 11	Patterns	The "next term" in a simple sequence	132
		Square and triangular numbers	133 - 134
		Linear patterns $M = 2t$ etc	135 - 138
		Harder linear patterns $M = 2t + 3$ etc	139 - 143
		Topic in a Nutshell	144 - 145
Ch 12	Angles	Revise types of angles and naming them	146 - 148
		Calculating missing angles	149 - 150
		Angles in a triangle	151 - 153
		Corresponding and alternate angles	154 - 159
		Topic in a Nutshell	160 - 161
Ch 13	Special Numbers	Multiples and factors	162 - 164
		Prime numbers	165 - 166
		Topic in a Nutshell	167
Ch 14	Drawing Triangles	Constructing triangles knowing 2 sides and included angle	168 - 169
		Constructing triangles knowing 2 angles and a side.	170 - 171
		Constructing triangles knowing 3 sides	172 - 173
		Topic in a Nutshell	174
Ch 15	Ratio	Understanding ratios	175 - 176
		Simplifying ratios	177 - 179
		Ratio calculations	179 - 181
		Topic in a Nutshell	182
Ch 16	Volumes	Revision of volumes of shapes by counting cubes	183 - 186
		Volume by formulae	186 - 188
		Liquid volumes - 1 litre = 1000 ml = 1000 cm ³	189 - 191
		Topic in a Nutshell	192 - 193
Ch 17	Scale Drawing	Interpreting and using scales	194 - 196
		Simple scale drawings	197 - 198
		Scale drawings using a protractor	199 - 201
		Bearings and scale drawings	202 - 205
		Topic in a Nutshell	206 - 207
Ch 18	Quadrilaterals	Revise square and rectangle	208 - 212
		The angles of a quadrilateral	213
		Rhombus - properties and angles	214 - 217
		Kite - properties and angles	218 - 220
		Parallelogram - properties and angles	221 - 224
		Trapezium - property and angles	224 - 225
		Topic in a Nutshell	226 - 227
Ch 19	Circles	Parts of the circle - connection between radius & diameter	228
		Circumference and $C = \pi D$	229 - 232
		Topic in a Nutshell	233
Ch 20	3D work	Nets of cubes and surface areas	234 - 235
		Nets of cuboids and surface areas	236 - 238
		Nets of triangular prisms	239
		Topic in a Nutshell	240
Revision of all Level E work	Answers	241 - 251	

Chapter 0

Level D Consolidation

The following questions (pages 1 - 8) cover every topic from Level D. (No calculator unless stated)



- Write the following **in words** :-
 a 23 090 b 60 280 c 9003 d 98 026.
- Write the following **in figures** :-
 a forty two thousand and eighteen b eighty nine thousand three hundred.
- Put in order, **smallest** first :-
 20 105, 19 000, 20 009, 19 780, 21 000, 19 099.
- What does the **6** in the number 86 095 represent ?
- a What is the number that is **500 up from** 197 000 ?
 b What number is **100 down from** 72 000 ?
- Find the missing values :-
 a $\frac{3}{4} = \frac{?}{20}$ b $\frac{35}{50} = \frac{?}{10}$ c $\frac{30}{40} = \frac{?}{100}$.
- Write the number $6 + \frac{3}{10} + \frac{7}{100}$ as a **decimal**.
- Change the following to **decimals** :- a 17% b 68% c 9%.
- Copy this table and complete it :-



metres & centimetres	2m 17cm
metres	3.06 m
centimetres	185 cm	...

- a I bought a shirt for £7.99 and a tie for £6.49. How much **change** did I receive from £20 ?
 b What notes and coins might I receive in my change ?
- Find (**mentally**) the following :-
 a $73 + 27$ b $85 - 23$ c $47 + 57$ d $72 - 58$
 e $240 + 320$ f $590 - 420$ g $99 + 85$ h $510 - 370$.



12. Copy the following and find :-

$$\begin{array}{r} a \quad 4927 \\ + 869 \\ \hline \end{array}$$

$$\begin{array}{r} b \quad 56 \cdot 81 \\ - 12 \cdot 93 \\ \hline \end{array}$$

$$\begin{array}{r} c \quad 8000 \\ - 169 \\ \hline \end{array}$$

d $9 - 2 \cdot 63$.

13. Find (mentally) the following :-

a 13×7

b $96 \div 4$

c $320 \div 8$

d 230×4 .



14. Find (mentally) the following :-

a 23×10

b 100×340

c 102×100

d $10 \times 6 \cdot 31$

e $25 \cdot 2 \div 10$

f $100 \times 0 \cdot 63$

g $650 \div 100$

h $1 \cdot 2 \times 100$.



15. Copy the following and find :-

$$\begin{array}{r} a \quad 4 \cdot 13 \\ \times 5 \\ \hline \end{array}$$

$$\begin{array}{r} b \quad 17 \cdot 26 \\ \times 8 \\ \hline \end{array}$$

c $18 \cdot 27 \div 7$

d $1 \cdot 08 \div 9$.

16. Round to the nearest 10 :-

a 72

b 396

c 4125

d 18 \cdot 26.

17. Round to the nearest 100 :-

a 349

b 2551

c 15879

d 6984.

18. Do the following, without a calculator :-

a $\frac{1}{5}$ of 35

b $\frac{1}{8}$ of 240

c $\frac{1}{7}$ of 4900

d $\frac{1}{10}$ of 2300.

19. Do the following without a calculator :-

a $\frac{3}{4}$ of 80

b $\frac{2}{3}$ of 120

c $\frac{7}{10}$ of 3000

d $\frac{4}{5}$ of 105.

20. Remember - 20% means $\frac{20}{100}$. Find the following :-

a 20% of 6000

b 30% of 400

c 60% of 2000

d 90% of 300.

21. Write down the next three terms in each of the following patterns :-

a 2, 4, 6, 8, ...

b 13, 15, 17, 19, ...

c 3, 6, 9, 12, ...

d 160, 80, 40, 20, ...

e 1, 2, 4, 8, ...

f 3, 7, 11, 15, ...

g 9, 15, 21, 27, ...

h 100, 93, 86, 79, ...

22. Can you see the pattern here ?

1, 1, 2, 3, 5, 8, 13, 21, 34, ..., ..., ..., ...

Find the next four terms.

23. If you know the length of the side of a square, describe "in words" what you do to calculate its perimeter.

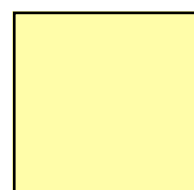

length = ?

24. a **Measure** this line in centimetres and in millimetres.

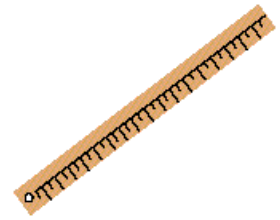

b Write its length in "3" different ways.

25. Say which of the following is the best **approximation** :-

- a a lady's weight. - {5 kg, 40 kg, 200 kg, 750 g}
- b a boy's height. - {95 cm, 160 cm, 240 cm, 3.1 m}
- c volume of water in a full cup. - {5 ml, 30 ml, 200 ml, 2.3 litres}



26. Change the following (am/pm) times to **24 hour format** :-

- a 7:15 am
- b 5 to 3 in the afternoon
- c $\frac{1}{4}$ to midnight
- d 9:05 at night
- e 5 past midnight
- f 12:45 pm

27. Change the following 24 hour times into **12 hour form** (use am/pm) :-

- a 0945
- b 1620
- c 2255
- d 0010

28. a A film begins at 7:30 pm and lasts for 1 hour 50 minutes.

At what time will the film finish ?

b A classical concert began at 1:45 pm and finished at 8:20 pm.

For how long did the concert last ?



29. Calculate the **perimeter** of the following shapes :-

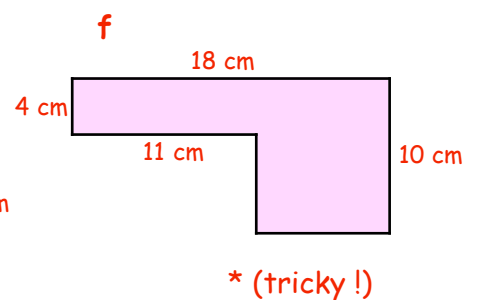
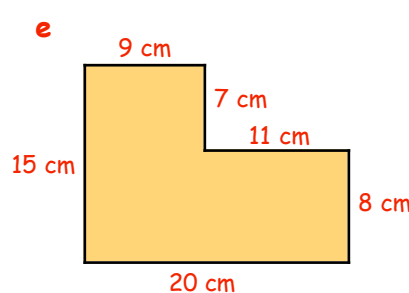
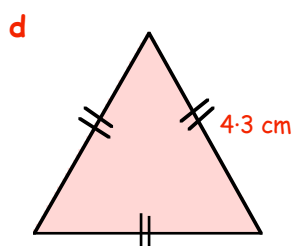
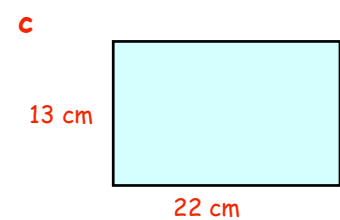
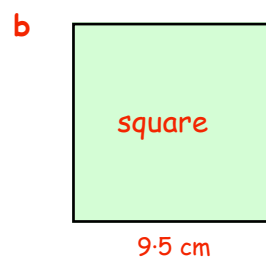
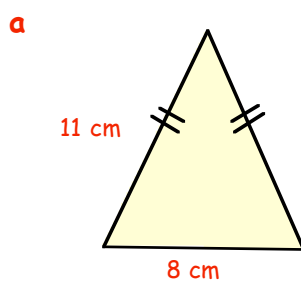

30. Each box in the following figures represents 1 square centimetre (1 cm^2). Write down the **area** of each shape (in cm^2).

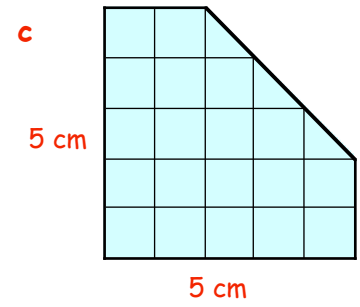
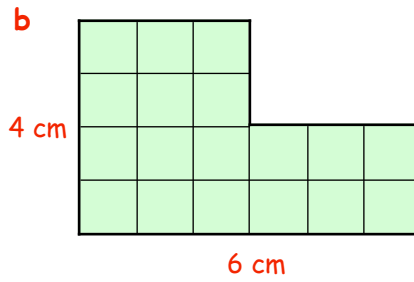
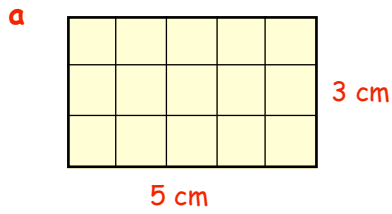

31. a Draw the triangle shown opposite accurately on squared paper. (each box is 1 cm by 1 cm).
 b Calculate the **area** of the surrounding rectangle.
 c Write down the **area** of the right angled triangle.

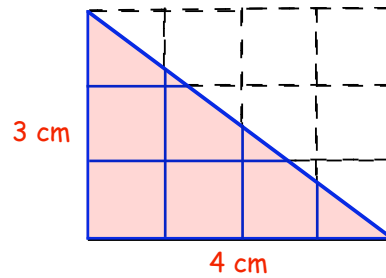

32. Calculate the **area** of each of the following right angled triangles. (you may like to draw them first).

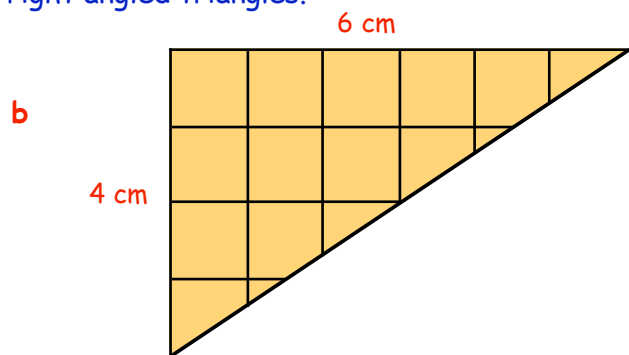
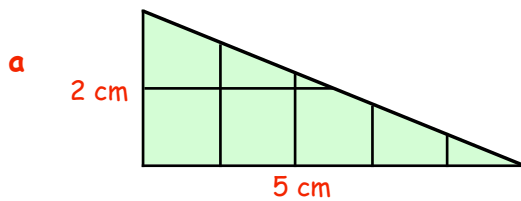

33. Name the following shapes :-

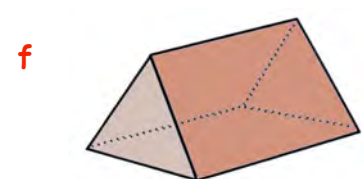
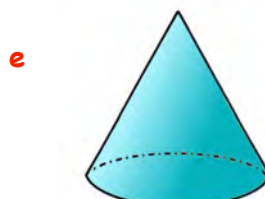
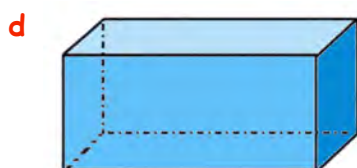
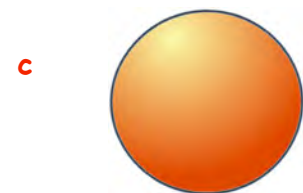
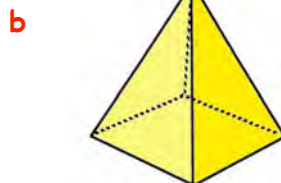
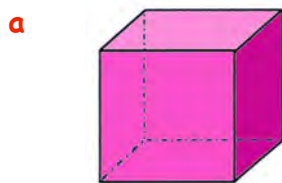

34. How many **faces** (surfaces) has a :-

- a cube ?
- b triangular prism ?
- c cone ?
- d square based pyramid ?



35. How many **vertices** (corners) has a :-

- a square based pyramid ?
- b triangular prism ?
- c cuboid ?

36. Name the following shapes :-

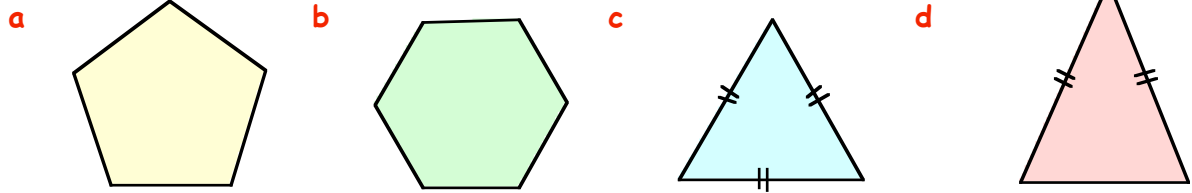

37. Sketch this circle and name its parts.

- a is
- b is
- c is

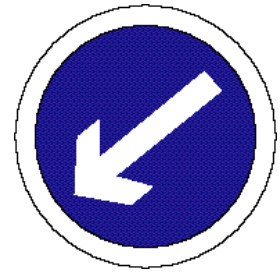
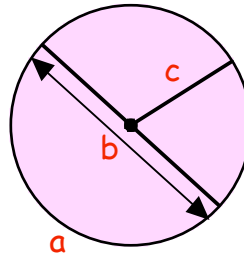

38. Shown below are **nets** of solids. Say which solid could be made from each :-

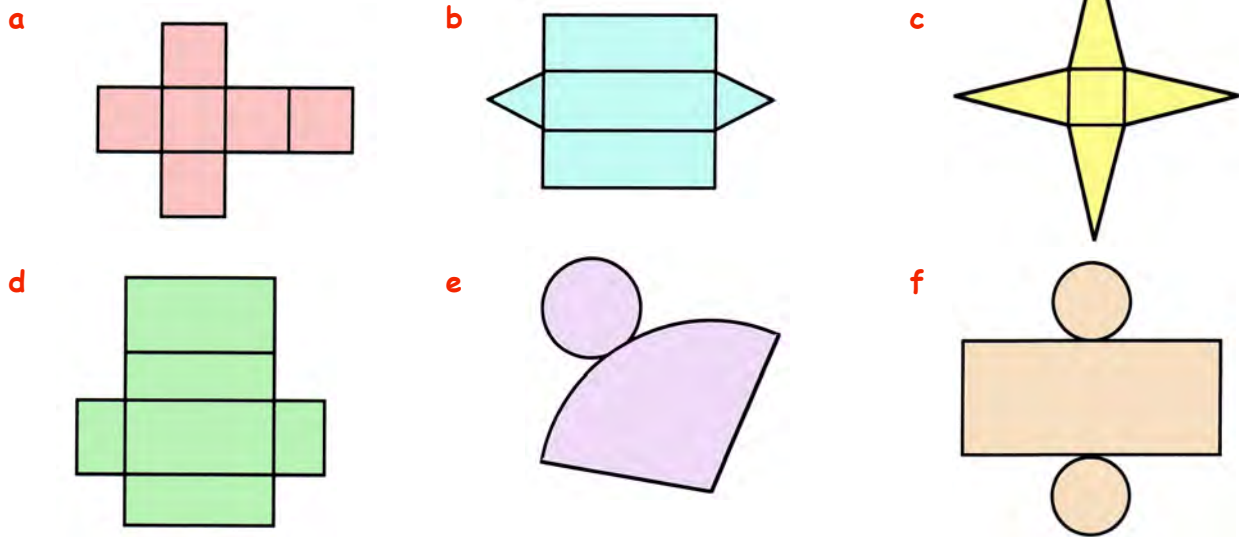

39. **Copy** this compass rose and fill in the other 7 directions.

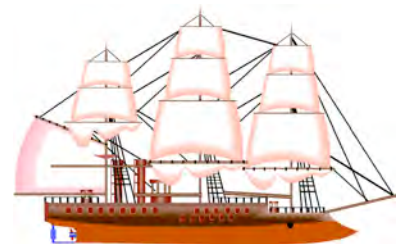
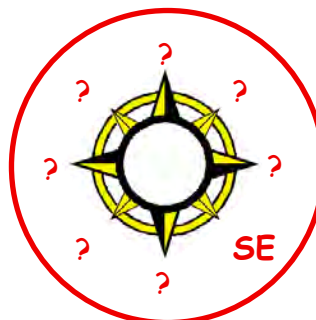

40. I am walking North West.
I turn through an angle of 90° clockwise.
In which direction am I now facing ?

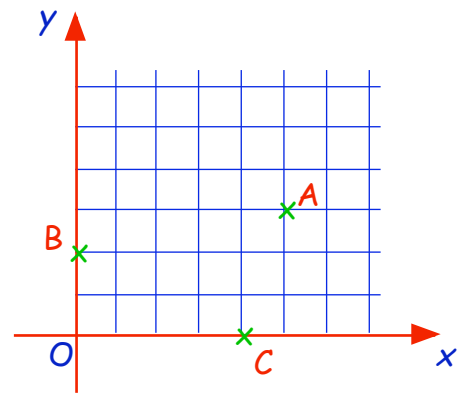

41. Write down the coordinates of the three points, **A**, **B** and **C** in the coordinate diagram shown opposite.

42. How many **lines of symmetry** do the following shapes have ?

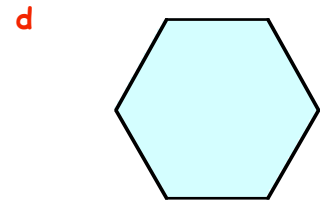
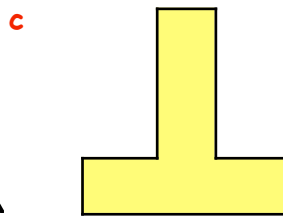
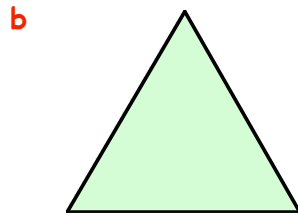
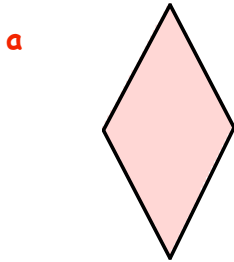

43. **Copy** or trace this figure carefully.
Complete the figure such that the dotted line is a **line of symmetry**.

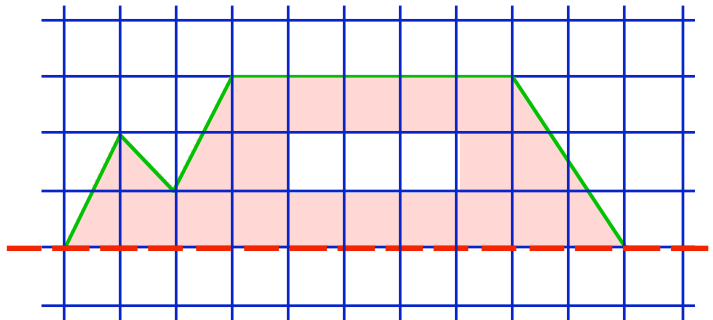

44. Repeat for this figure.

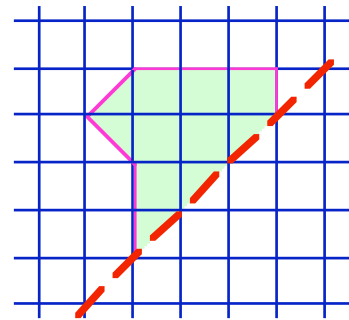

45. Use a **protractor** to measure the following two angles :-

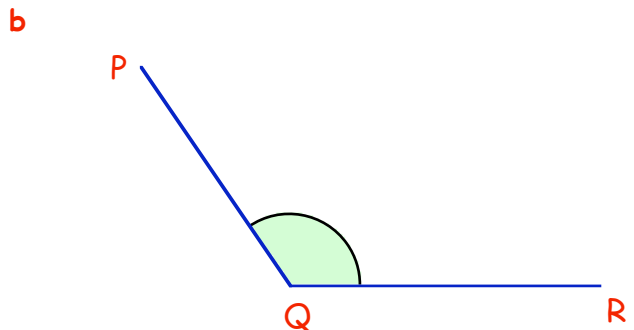
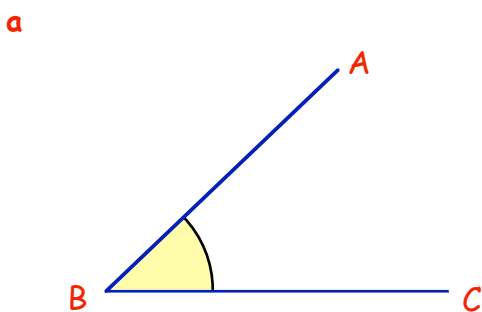

46. State what **type** of angle is shown in each of the following diagrams :-

a

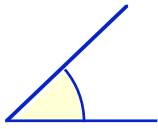

b

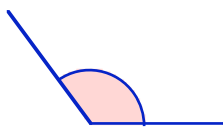

c

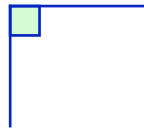

d



47. a Draw a line AB = 6 centimetres.

b Use a **protractor** to show $\angle CAB = 55^\circ$.



48. Use a **protractor** to draw (and label) the following angles :-

a $\angle PQR = 78^\circ$

b $\angle MNT = 123^\circ$.

49. This diagram shows the 4 main towns on an island, Ashleigh, Buckston, Carlton and Duns.

a Measure and write down the 3 figure bearing of Buckston from Ashleigh.

b Measure and write down the 3 figure bearing of Carlton from Ashleigh.

c Measure and write down the 3 figure bearing of Duns from Ashleigh.

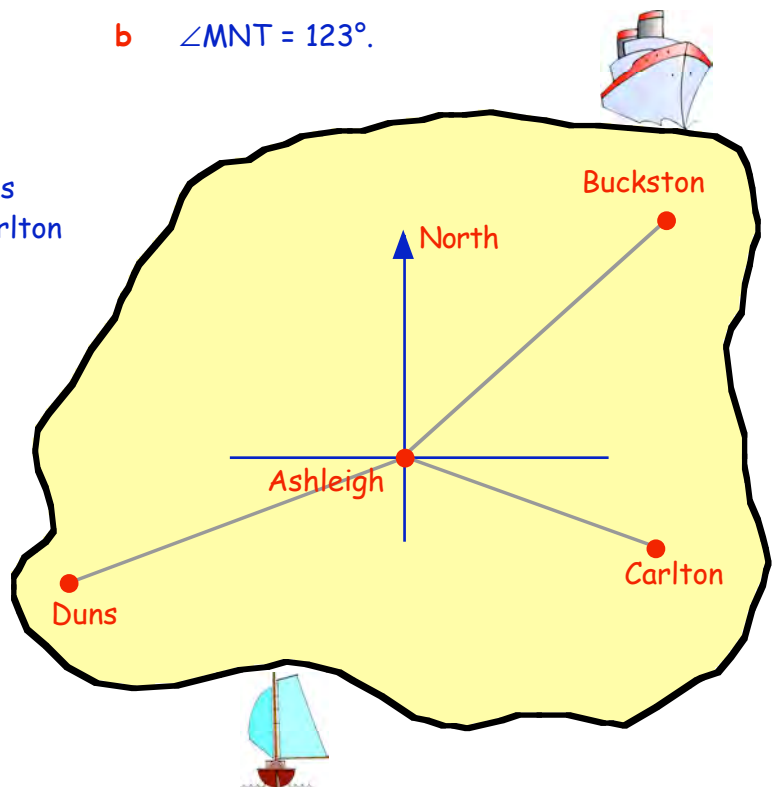

50. The table shows the eating habits of **all** the pupils in a small primary school one week.

a How many pupils were at school last week ?

b How many lunches were sold altogether in the canteen last week ?

c The local shop closed at lunch time one day last week. Which day ?

d A special "Xmas Day" lunch was served up one day in the canteen. Which day ?

Lunchtime	Mon	Tue	Wed	Thu	Fri
Go home	7	5	9	12	-
Packed lunch	17	18	16	20	10
Canteen	26	22	30	28	48
Local shop	10	15	5	-	2



51. A group of people took part in a survey.
The table shows the information gathered from them.



Initials	M/F	Age	Height (m)	Weight (kg)	Eye Colour
TD	M	29	1.73	67	Blue
JS	M	27	1.75	69	Green
IB	F	18	1.58	52	Blue
AP	M	39	1.80	71	Brown
DMcT	F	36	1.60	57	Grey
FN	F	28	1.53	53	Blue
NY	M	22	1.75	73	Green
MR	F	17	1.57	50	Blue
LS	M	27	1.79	77	Brown
AY	M	22	1.75	72	Green



- How many men were interviewed ?
- Who was the **oldest** person in the survey ?
- What colour of eyes did the **youngest** person have ?
- How many of the group were **over** 1.70 metres tall ?
- Who was the **lightest** male ?
- There were a pair of identical twins in the survey.
What age were they ?



52. A group of children were asked to name their favourite fruit.
The results of the survey are shown below.

Apple	Orange	Banana	Pear	Grape	Peach	Melon
17	11	22	10	16	7	5



Draw a neat labelled **bar graph** to represent the above results.

53. The **pie-chart** shows the results from a group of teenagers as to the name of the mobile phone company they used.

- What **fraction** of the group were with "2 - to - 2" ?
- If 160 teenagers took part in the survey, how many of them were with :-
(i) Yellow ? (ii) Q₂ ?

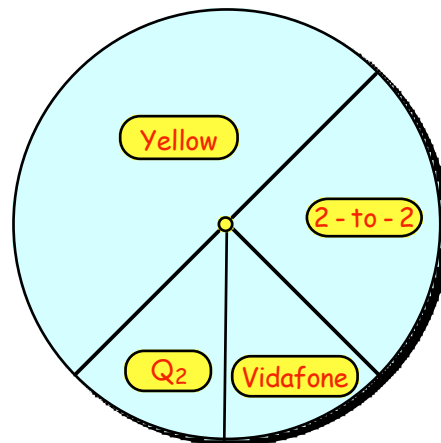

Chapter 1

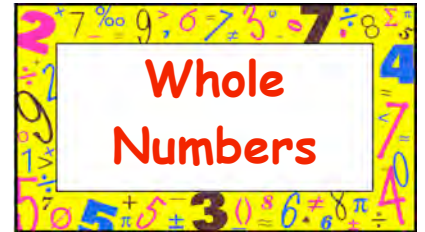

Place Values

Calculators should **not** be used anywhere in this Chapter except in the final exercise.

Exercise 1

- In the number 23645, the **3** stands for **3000**.
What do the following digits stand for in the number 23645 :-
a 6 b 4 c 5 d 2 ?
- What does the **8** stand for in each of these numbers :-
a 63810 b 24384 c 128400 d 852030 ?
- Write the following numbers out fully **in words** :-
a 2070 b 31400 c 60850 d 123010
e 806490 f 1320000 g 2085060 h 13000075
- Write the following numbers **using digits** :-
a six thousand, four hundred and seven.
b nineteen thousand and eighty.
c forty thousand and sixty three.
d one hundred and nine thousand, two hundred and forty five.
e six hundred and eighty thousand and twenty.
f two million, one hundred and nine thousand.
g ten million, eighty thousand and sixty.
- Put the following sets of numbers in order, **smallest** first :-
a 8079, 7987, 8097, 7897, 8009, 8090, 7978.
b 100650, 99875, 101000, 98797, 90999, 100088.
- Write down the number that is :-
a 50 after 870 b 100 after 9910
c 40 before 9990 d 300 before 10240
e 2000 after 139600 f 500 before 1000000
g 30000 after 890001 h 400000 before 2210000.

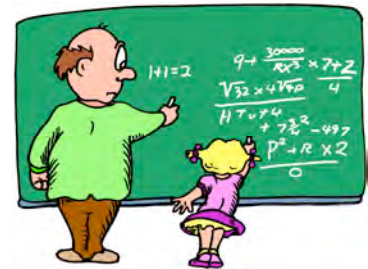

7. Look at the following scales. What numbers are represented by the letters A, B, C, ...

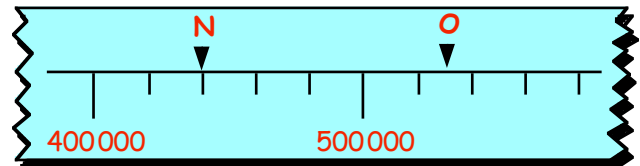
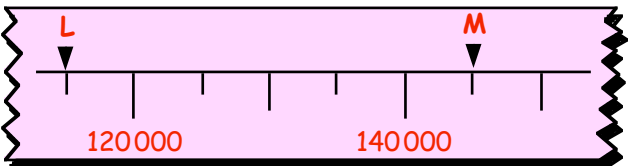
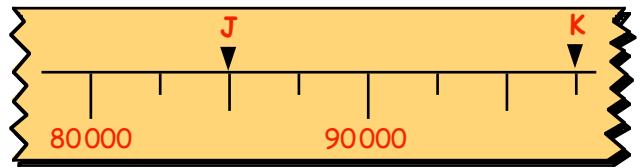
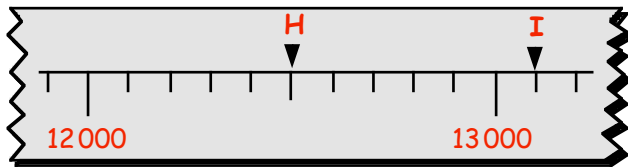
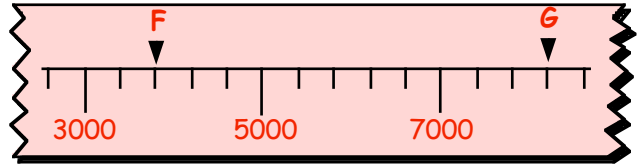
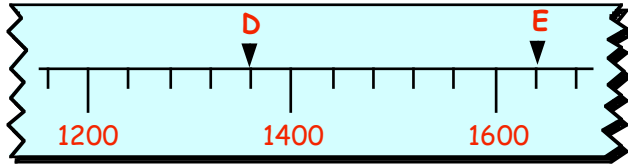
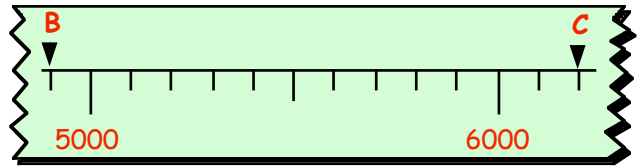
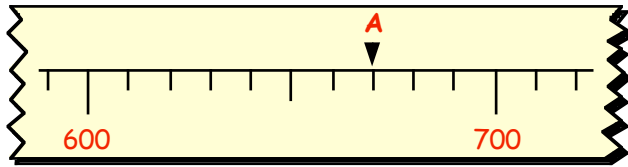

8. What number lies **half-way** between :-

- a 120 and 130 ?
- b 1500 and 1600 ?
- c 22 000 and 22 400 ?
- d 210 000 and 270 000 ?
- e 17 500 and 22 500 ?
- f 63 800 and 64 600 ?

9. Write out in **figures** :-

- a 1 million
- b $\frac{1}{2}$ million
- c $\frac{1}{4}$ million
- d $\frac{3}{4}$ million.

10. The population of Glasgow in 1980 was 1100 000.
During the rest of the 80's, the population **dropped** by 150 000.
What was the population at the end of the 80's ?



11.  Davie's salary was £28 000 per year and Alex's was £33 000.
Sam discovered she earned **half way** between Davie's and Alex's.
How much did Sam earn ?

12. After a severe drought and famine, an African country received **£5 billion** in aid.
Write out this amount **in full**.



Add/Subtract Whole Numbers

There are **quick ways** of adding and subtracting numbers.

Example :- To add 390 and 540,

=> you could add $400 + 540 = 940$, then subtract 10 => 930.

Exercise 2



1. Try to do the following **mentally**. Just write down the answers to :-

- | | | | | | | | |
|---|---------------|---|---------------|---|---------------|---|----------------|
| a | $29 + 36$ | b | $54 + 66$ | c | $19 + 75$ | d | $58 + 88$ |
| e | $70 - 45$ | f | $69 - 54$ | g | $100 - 73$ | h | $90 - 39$ |
| i | $260 + 190$ | j | $390 + 520$ | k | $270 + 630$ | l | $720 + 990$ |
| m | $860 - 330$ | n | $790 - 410$ | o | $700 - 120$ | p | $1000 - 290$ |
| q | $410 - 350$ | r | $720 - 690$ | s | $430 - 190$ | t | $840 - 670$ |
| u | $2300 + 6500$ | v | $2900 + 5700$ | w | $4800 - 2300$ | x | $10000 - 6900$ |

2. Do the following **mentally** :-

- a As a bus approached a stop, there were 49 people on board. At the stop, a further 13 passengers got on. How many were there now on the bus ?



- b Of the 870 pupils in a school, 460 of them were boys. How many girls were there ?

- c Charles earned £870 per month and Angela earned £690.

- (i) How much did they earn altogether ?
(ii) How much more did Charles earn than Angela ?



d



Of the 3100 miles from London to New York, a plane had flown 1700 miles. How much further had it to travel ?

- e A Mazda car cost £9200 when new. After 2 years, its value dropped by £3400. How much was it then worth ?



- f Richard was left £1000 by his gran in her will. He spent £390 on a new computer. How much had Richard left ?

- g I won £9900 on the lottery and £4700 on the football pools. How much had I won altogether ?



3. Copy the following and find the answers :-

a
$$\begin{array}{r} 295 \\ + 186 \\ \hline \end{array}$$

b
$$\begin{array}{r} 389 \\ + 274 \\ \hline \end{array}$$

c
$$\begin{array}{r} 695 \\ + 377 \\ \hline \end{array}$$

d
$$\begin{array}{r} 987 \\ + 648 \\ \hline \end{array}$$

e
$$\begin{array}{r} 728 \\ - 276 \\ \hline \end{array}$$

f
$$\begin{array}{r} 4046 \\ + 2813 \\ \hline \end{array}$$

g
$$\begin{array}{r} 3067 \\ + 5819 \\ \hline \end{array}$$

h
$$\begin{array}{r} 3874 \\ - 1876 \\ \hline \end{array}$$

i
$$\begin{array}{r} 1000 \\ - 832 \\ \hline \end{array}$$

j
$$\begin{array}{r} 9165 \\ + 3684 \\ \hline \end{array}$$

k
$$\begin{array}{r} 7036 \\ - 2985 \\ \hline \end{array}$$

l
$$\begin{array}{r} 10000 \\ - 8849 \\ \hline \end{array}$$

m $3864 + 299$

n $5637 + 8475$

o $9103 - 7684$

p $6000 - 398$

q $2975 + 1786$

r $3001 - 1999$

s $9945 + 199$

t $20000 - 14850$

4. Show all your working whilst doing the following problems :-

a There were 8769 Hibs Supporters and 7428 Hearts supporters at the local derby match.

(i) How many supporters were there altogether ?

(ii) How many **more** Hibs than Hearts supporters were there ?

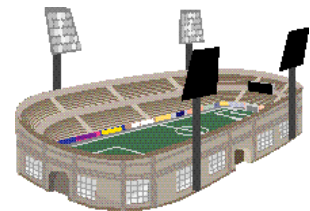

b By the end of 2001, my car had travelled 8467 miles. During 2002, I drove a further 6758 miles.

How much had my car travelled altogether by the end of 2002 ?

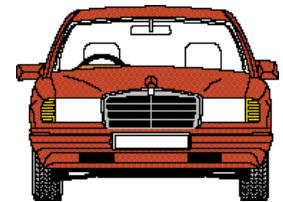

c My salary last year was £12 640. This year it rose by £1970.

What was my salary this year ?



d During a storm, a plane dropped in height from 33 680 feet to 29 870 feet.

By how much had it dropped ?

e After a trial, a man won £10 000 in damages. His legal bill came to £4 275.

How much was he left with after paying his legal fees ?



5. Shown is a magic honeycomb. It uses the numbers 1, 2, 3, up to 19. All the numbers in each row or in the direction of each arrow add to give 38.

Make a **copy** of the honeycomb and find where the missing numbers go.

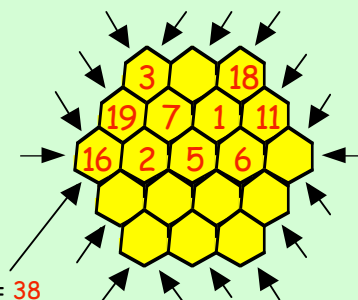

$3 + 19 + 16 = 38$

Multiply and Divide Whole Numbers

For this, you **really must know your tables**.

Learn them **NOW** - they are a must !!.

$2 \times 2 = 4$
$2 \times 3 = 6$
$2 \times 4 = 8$
$2 \times 5 = 10$
$2 \times 6 = 12$
$2 \times 7 = 14$
$2 \times 8 = 16$
$2 \times 9 = 18$

$3 \times 2 = 6$
$3 \times 3 = 9$
$3 \times 4 = 12$
$3 \times 5 = 15$
$3 \times 6 = 18$
$3 \times 7 = 21$
$3 \times 8 = 24$
$3 \times 9 = 27$

$4 \times 2 = 8$
$4 \times 3 = 12$
$4 \times 4 = 16$
$4 \times 5 = 20$
$4 \times 6 = 24$
$4 \times 7 = 28$
$4 \times 8 = 32$
$4 \times 9 = 36$

$5 \times 2 = 10$
$5 \times 3 = 15$
$5 \times 4 = 20$
$5 \times 5 = 25$
$5 \times 6 = 30$
$5 \times 7 = 35$
$5 \times 8 = 40$
$5 \times 9 = 45$

$6 \times 2 = 12$
$6 \times 3 = 18$
$6 \times 4 = 24$
$6 \times 5 = 30$
$6 \times 6 = 36$
$6 \times 7 = 42$
$6 \times 8 = 48$
$6 \times 9 = 54$

$7 \times 2 = 14$
$7 \times 3 = 21$
$7 \times 4 = 28$
$7 \times 5 = 35$
$7 \times 6 = 42$
$7 \times 7 = 49$
$7 \times 8 = 56$
$7 \times 9 = 63$

$8 \times 2 = 16$
$8 \times 3 = 24$
$8 \times 4 = 32$
$8 \times 5 = 40$
$8 \times 6 = 48$
$8 \times 7 = 56$
$8 \times 8 = 64$
$8 \times 9 = 72$

$9 \times 2 = 18$
$9 \times 3 = 27$
$9 \times 4 = 36$
$9 \times 5 = 45$
$9 \times 6 = 54$
$9 \times 7 = 63$
$9 \times 8 = 72$
$9 \times 9 = 81$

Multiplication by 10, 100, 1000

Learn these rules

Example :- $237 \times 10 = 2370$

Simple rules for whole numbers :-

If you multiply by **10**, simply add **one 0** at the end.

If you multiply by **100**, simply add **two 0's** at the end.

If you multiply by **1000**, simply add **three 0's** at the end.

Exercise 3



1. Write down the answers to the following :-

a 19×10

b 12×10

c 37×10

d 10×93

e 10×117

f 205×10

g 10×346

h 10×1850

i 2060×10

j 2875×10

k 10×54321

l 23050×10

2. Write down the answers to the following :-

a 26×100

b 58×100

c 100×122

d 100×300

e 4050×100

f 100×1006

g 100×9500

h 80600×100

3. Write down the answers to these :-

- a 17×1000 b 213×1000 c 360×1000 d 1000×930
e 1000×400 f 1240×1000 g 1000×3800 h 1000×52020

4. A jar contain 100 lollipops. How many lollies are there in :-

- a 13 jars b 27 jars c 214 jars ?

5. There are 1000 metres in 1 kilometre. How many metres are there in :-

- a 7 km b 23 km c 320 km d 3005 km ?

Division by 10, 100, 1000

Learn these rules

Example :- $7900 \div 100 = 79$

Simple rules for whole numbers :-

If you divide by 10, simply remove last 0

If you divide by 100, simply remove last two 0's

If you divide by 1000, simply remove last three 0's

Exercise 4

1. Write down the answers to the following :-

- a $180 \div 10$ b $260 \div 10$ c $480 \div 10$ d $1230 \div 10$
e $7600 \div 10$ f $40200 \div 10$ g $69300 \div 10$ h $51000 \div 10$
i $10000 \div 10$ j $143000 \div 10$ k $200000 \div 10$ l $5050500 \div 10$



2. Write down the answers to the following :-

- a $900 \div 100 = \dots$ b $1700 \div 100$ c $5200 \div 100$ d $16000 \div 100$
e $8000 \div 100$ f $105000 \div 100$ g $20000 \div 100$ h $1400000 \div 100$

3. Write down the answers to the following :-

- a $7000 \div 1000$ b $29000 \div 1000$ c $78000 \div 1000$ d $30000 \div 1000$
e $265000 \div 1000$ f $370000 \div 1000$ g $900000 \div 1000$ h $3100000 \div 1000$

4. A hospital box holds 100 samples. How many boxes are needed to hold :-

- a 1300 samples b 37000 samples c 120000 samples ?



5. There are 1000 grams in 1 kilogram. How many kilograms are there in :-

- a 15000 grams b 56000 grams c 160000 grams d 1000000 grams ?

6. There are 10 millimetres in 1 centimetre, 100 centimetres in 1 metre and 1000 metres in 1 kilometres. How many kilometres are equivalent to :-

- a 7000 m b 600000 cm c 5000000 mm ?

Multiplication by a Single Digit

This is where knowing your tables really pays off !

Example :- $3276 \times 8 = >$

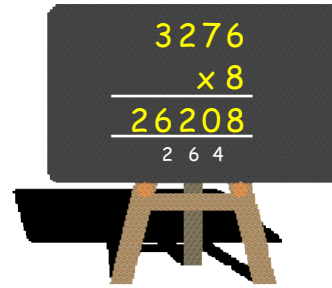

Exercise 5

1. Copy the following and complete the calculation :-

a
$$\begin{array}{r} 748 \\ \times 3 \\ \hline \\ \hline \end{array}$$

b
$$\begin{array}{r} 296 \\ \times 5 \\ \hline \\ \hline \end{array}$$

c
$$\begin{array}{r} 407 \\ \times 9 \\ \hline \\ \hline \end{array}$$

d
$$\begin{array}{r} 1243 \\ \times 4 \\ \hline \\ \hline \end{array}$$

e
$$\begin{array}{r} 3026 \\ \times 7 \\ \hline \\ \hline \end{array}$$

f
$$\begin{array}{r} 5217 \\ \times 8 \\ \hline \\ \hline \end{array}$$

g
$$\begin{array}{r} 9070 \\ \times 6 \\ \hline \\ \hline \end{array}$$

h
$$\begin{array}{r} 9876 \\ \times 9 \\ \hline \\ \hline \end{array}$$

2. Rewrite each of these in the above form and complete the calculation :-

a 509×8

b 817×7

c 954×4

d 1804×6

e 7×6254

f 5×2037

g 2076×9

h 3×9987

3. Show your working in answering the following questions :-

- a A "gross" in mathematics is twelve dozen (or 144).
Pencils used to be sold to schools in gross.
How many pencils were in a box of 7 gross ?



- b Bob earns £2175 per month.
How much will he earn in 6 months ?



- c  An hour consist of (60×60)
 $= 3600$ seconds.
How many seconds are there in 8 hours ?

- d A palette holds 2096 tins of soup.
How many tins are there altogether
in 9 palettes ?



- e Find the value of $4 \times 7 \times 236$.

- f A wallpaper border is 8 centimetres wide
and 2175 centimetres long.
Calculate its area (Area = length \times breadth).

- g A satellite travels at 7642 km per hour.
How far will it fly in 9 hours ?

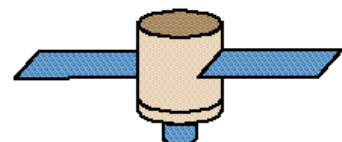

Long Multiplication

This is **beyond** level E (or F!) but should give extra practice at multiplication by 1 digit.

Example:- Find 356×47

Step 1 :- multiply the **356** by the **7** (= 2492).

Step 2 :- now multiply by **40**, not 4. (= 14240)

(it's easier to put a 0 (zero) below the 2 and then multiply by the 4).

Step 3 :- now simply **add your 2 answers**.

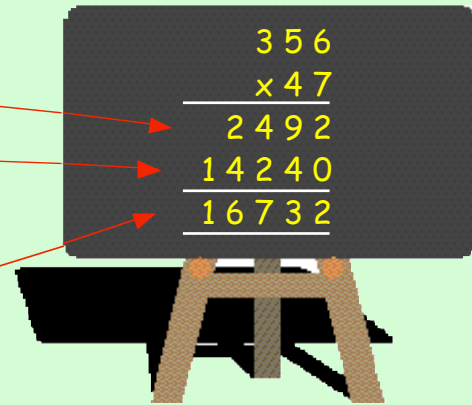

Exercise 6

1. Copy down this long multiplication calculation and complete it.

$$\begin{array}{r} 247 \\ \times 36 \\ \hline 1482 \\ \dots\dots 0 \\ \hline \dots\dots\dots \\ \hline \dots\dots\dots \end{array}$$

2. Set down and do the following :-

a

$$\begin{array}{r} 153 \\ \times 72 \\ \hline \dots\dots\dots \\ \dots\dots\dots 0 \\ \hline \dots\dots\dots \end{array}$$

b

$$\begin{array}{r} 436 \\ \times 48 \\ \hline \dots\dots\dots \\ \dots\dots\dots 0 \\ \hline \dots\dots\dots \end{array}$$

c

$$\begin{array}{r} 804 \\ \times 92 \\ \hline \dots\dots\dots \\ \dots\dots\dots \\ \hline \dots\dots\dots \end{array}$$

d

$$\begin{array}{r} 556 \\ \times 55 \\ \hline \dots\dots\dots \\ \dots\dots\dots \\ \hline \dots\dots\dots \end{array}$$

e

$$\begin{array}{r} 1264 \\ \times 32 \\ \hline \dots\dots\dots \\ \dots\dots\dots \\ \hline \dots\dots\dots \end{array}$$

f

$$\begin{array}{r} 2598 \\ \times 63 \\ \hline \dots\dots\dots \\ \dots\dots\dots \\ \hline \dots\dots\dots \end{array}$$

g

$$\begin{array}{r} 4107 \\ \times 85 \\ \hline \dots\dots\dots \\ \dots\dots\dots \\ \hline \dots\dots\dots \end{array}$$

h

$$\begin{array}{r} 7612 \\ \times 48 \\ \hline \dots\dots\dots \\ \dots\dots\dots \\ \hline \dots\dots\dots \end{array}$$

3. Set the following down in the manner shown above and find :-

a 236×17

b 805×26

c 37×549

d 73×1023

e 8204×29

f 7777×54

g 4706×83

h 57×9217

4. **a** Make an attempt, **on your own**, to try this question :-

b Check your answer.

c If you got it correct, try finding :-

(i) 6217×358

(ii) 7036×572

$$\begin{array}{r} 3245 \\ \times 243 \\ \hline \dots\dots\dots \\ \dots\dots\dots \\ \hline \dots\dots\dots \end{array}$$

Division by a Single Digit

Again, knowing your tables is a must !

Example :- $5856 \div 8 = ?$

$$\begin{array}{r} 732 \\ 8 \overline{) 5856} \end{array}$$



Exercise 7

1. Copy the following and complete the calculation :-

a $7 \overline{) 3808}$

b $5 \overline{) 9265}$

c $6 \overline{) 7434}$

d $8 \overline{) 5216}$

e $4 \overline{) 6384}$

f $3 \overline{) 7008}$

g $7 \overline{) 8764}$

h $9 \overline{) 8865}$

2. Set the following down in the same way as above and complete the calculation :-

a $5915 \div 7$

b $4752 \div 2$

c $9465 \div 5$

d $8703 \div 9$

e $7728 \div 8$

f $6316 \div 4$

g $8706 \div 6$

h $6561 \div 3$

i $6858 \div 9$

j $\frac{5033}{7}$

k $\frac{1936}{4}$

l $4536 \div 8$

m $\frac{9072}{6}$

n $6735 \div 5$

o $\frac{7533}{9}$

p $\frac{6083}{7}$

3. Show how you obtain your answers to the following :-

a A week consists of 7 days.
How many weeks are there in 805 days ?

b Eggs are packed into boxes of 6.
How many boxes are needed to pack 4086 eggs ?

c Nine people won a total of £5283. If it is shared **equally** amongst them, how much will each receive ?

d



Chocolate biscuits are packed into jars of 8.
One day, the factory produces 7552 biscuits.
How many jars are needed to pack them all ?

e Find the answer to $9436 \div 4 \div 7$.

f Blank DVD's in their cases are priced at £9 for 10.
How many packs of 10 could a shopkeeper buy with £3267 ?



g Find the answer to $6 \times 847 \div 7$.

Not all divisions work out exactly !!

$$\begin{array}{r} 823 \text{ r } 6 \\ 9 \overline{) 7413} \end{array}$$

4. Find the remainder each time here :-

a $2 \overline{) 7135}$

b $5 \overline{) 2314}$

c $7 \overline{) 4062}$

d $4 \overline{) 3143}$

e $513 \div 8$

f $2715 \div 6$

g $4317 \div 9$

h $6134 \div 10$

i $\frac{4444}{6}$

j $\frac{1827}{8}$

k $\frac{3143}{5}$

l $\frac{6172}{3}$

5. A bag contains 135 sweets. If they are shared equally amongst 8 children :-

a how many will each child receive ?

b how many sweets are left over ?



Tennis balls are packed into boxes of 6.

a How many boxes are needed for 1000 balls ?

b How many tennis balls are left over ?

7. **Hard !!** You may use a **calculator** here, but show how you obtained your answer.

$$3157 \div 23 = 137 \text{ r } 6$$



Find the answer and remainder :-

a $389 \div 17$

b $6102 \div 21$

c $5071 \div 19$

d $2345 \div 27$

e $6213 \div 35$

f $9027 \div 48$

g $5113 \div 36$

h $2135 \div 117$

8. a A for Apple

$$\begin{array}{r} A A \\ + A A \\ \hline B B C \end{array}$$

Replace A, B and C with digits to make this sum work.

b Its just SO-SO

$$\begin{array}{r} S O \\ S O \\ S O \\ + S O \\ \hline T S \end{array}$$

Find S, O and T.

c P's in a Pod

$$P + P + P = HP$$

Find P & H.

9. **The Four 4's problem.**

Using EXACTLY **four** 4's, along with + - x ÷, it is possible to create almost every number from 1 to 50.

Try to create all the numbers from 1 - 10 using 4 fours.

$$2 = \frac{4 \times 4}{4 + 4}$$

$$1 = \frac{4 + 4}{4 + 4}$$

$$11 = 44 \div 4$$

Multiplication/Division by Multiples of 10, 100, 1000

Multiplication by 20, 300, 4000 etc.

To multiply by 20, 300 or 4000, do it using **two steps**.

Step 1 => multiply by the 10, 100 or 1000 first

Step 2 => then multiply by the 2, 3, 4 etc

Examples :-

To multiply 763×20

Step 1 Find $763 \times 10 = 7630$ (easy)

Step 2 Now find

$$\begin{array}{r} 7630 \\ \times 2 \\ \hline 15260 \end{array}$$

To multiply 315×400

Step 1 Find $315 \times 100 = 31500$ (easy)

Step 2 Now find

$$\begin{array}{r} 31500 \\ \times 4 \\ \hline 126000 \end{array}$$

Exercise 8

1. Try to do the following **mentally** :- (use the 2-step approach)

a 23×30

b 31×40

c 12×80

d 52×60

e 20×112

f 50×403

g 41×900

h 600×62

i 115×700

j 300×423

k 2000×43

l 120×4000



2. Calculate each of the following (not necessarily mentally) :-

a 215×30

[Find 10×215 first = 2150 and then find 2150×3]

b 519×50

c 406×40

d 2145×80

e 810×90

f 3156×70

g 2708×60

3. Work out each of the following using the 2 steps shown :-

a 304×300

[Find 304×100 first = 30400 and then find 30400×3]

b 241×200

c 123×600

d 134×800

e 412×500

f 203×700

g 431×400

h 900×205

i 600×711

j 2000×621

k 402×5000

l 341×3000

m 623×4000

n 9000×117

o 6000×2015

p 7000×3120

4. There is a quick way of doing the following multiplications **mentally** :-

Example :- $70\,000 \times 4\,000$

=> simply find $7 \times 4 (= 28)$ and add on **7 zeros** => $280\,000\,000$

Do the following **mentally** :-

a 40×30

b 60×40

c 900×80

d 500×60

e $20 \times 3\,000$

f 50×400

g 800×900

h 600×700

i $4\,000 \times 600$

j $300 \times 8\,000$

k $2\,000 \times 4\,000$

l $8\,000 \times 9\,000$



5. Similarly, there is a quick way of doing the following divisions **mentally** :-

Example :- $120\,000 \div 4\,000$

=> simply cancel out **equal numbers** of zeros $120\cancel{000} \div 4\cancel{000}$

=> then do the simpler division $120 \div 4 = 30$

Do the following **mentally** :-

a $1\,500 \div 30$

b $2\,400 \div 40$

c $64\,000 \div 80$

d $12\,000 \div 600$

e $120\,000 \div 3\,000$

f $800\,000 \div 400$

g $7\,200\,000 \div 900$

h $56\,700\,000 \div 700$

i $4\,800\,000 \div 800$

j $3\,360\,000 \div 8\,000$

k $20\,000\,000 \div 4\,000$

l $8\,280\,000 \div 9\,000$



6. **a** A man counts the number of small square tiles on his rectangular bathroom wall.

He notes that there are 300 columns. Each column has 80 tiles in it.

How many tiles are there altogether ?

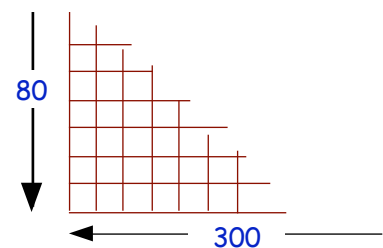

b The 400 workers in a factory do the lottery. They win the top prize of £3 600 000.

How much should each person receive ?

c A jar contains 3100 sweets.

How many sweets are there in 40 jars ?

d There are 3600 seconds in 1 hour.

How many seconds are there in 30 hours ?

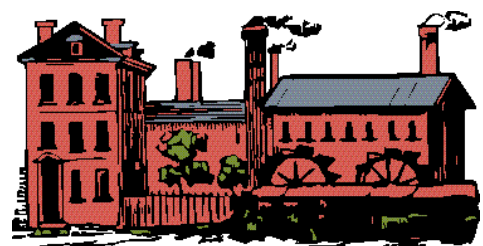

7. Remember the "Four 4's" problem on page 18.

Try to create the numbers from 11 - 20 using 4 fours.

e.g.

$$15 = 4 \times 4 - \frac{4}{4}$$

Rounding to nearest 10, 100 and 1000

To round to the nearest **10** look at the **units** digit :-

- if it is a 0, 1, 2, 3 or 4 - **leave** the 10's digit as it is.
- if it is a 5, 6, 7, 8 or 9 - round the 10's digit **up** by one.

To round to the nearest **100** look at the **tens** digit :-

- if it is a 0, 1, 2, 3 or 4 - **leave** the 100's digit as it is.
- if it is a 5, 6, 7, 8 or 9 - round the 100's digit **up** by one.

To round to the nearest **1000** look at the **hundreds** digit :-

- if it is a 0, 1, 2, 3 or 4 - **leave** the 1000's digit as it is.
- if it is a 5, 6, 7, 8 or 9 - round the 1000's digit **up** by one.

Exercise 9

1. Round to the nearest **10** :-

- | | | | | |
|-------|-------|--------|--------|--------|
| a 68 | b 72 | c 39 | d 75 | e 19 |
| f 112 | g 264 | h 383 | i 9 | j 105 |
| k 684 | l 549 | m 1836 | n 2802 | o 2098 |

2. Round to the nearest **100** :-

- | | | | | |
|----------|----------|----------|--------|----------|
| a 441 | b 671 | c 918 | d 384 | e 850 |
| f 666 | g 1536 | h 2093 | i 7890 | j 5643 |
| k 18 571 | l 27 350 | m 18 080 | n 2992 | o 19 895 |

3. Round to the nearest **1000** :-

- | | | | | |
|----------|-----------|-----------|-----------|-----------|
| a 7600 | b 15 300 | c 24 940 | d 19 870 | e 74 397 |
| f 72 504 | g 1961 | h 33 375 | i 85 920 | j 63 492 |
| k 79 875 | l 246 800 | m 325 493 | n 247 709 | o 599 864 |

4.



SOCCER

At a Glasgow football match, the attendance was 19 846.

Round this figure to the nearest :-

- a 10 b 100 c 1000.

5. The orbit of a satellite as it travels around the Earth is 43 967 kilometres.

Round this figure to the nearest :-

- a 10 b 100 c 1000.



Using Rounding to Estimate Answers

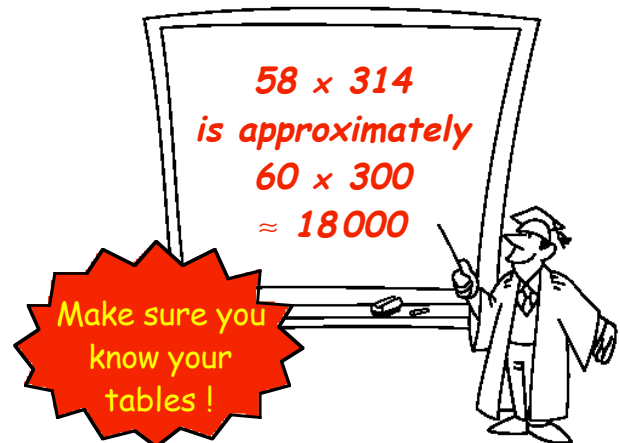

It is possible to "MENTALLY" estimate the answer to a question by rounding the numbers to "1 figure" accuracy first.

for example $878 \div 27$
is approximately $900 \div 30$
 $\approx 90 \div 3 \approx 30$



Exercise 10

- The answer to 96×52 is either {492, 4992 or 49092}. (no calculator !)
By rounding $96 \times 52 = 100 \times \dots = \dots$, decide which of the 3 answers has to be the correct one.
- Round your numbers before multiplying. Use this to decide which of the 3 given answers is most likely to be the correct one :-
 - 49×51 Choice of {249.9, 2499 or 29499}
 - 187×19 Choice of {3553, 7553 or 35553}
 - 314×78 Choice of {2486, 24492 or 248006}
 - 491×119 Choice of {5849, 18429 or 58429}
 - $59840 \div 187$ Choice of {30200, 3200 or 320}
- Round each number to 1 figure accuracy, then give an estimate to :-

a	51×49	b	67×32	c	79×99	d	296×31
e	408×67	f	587×279	g	$589 \div 19$	h	$3125 \div 27$
i	$3917 \div 189$	j	$58459 \div 321$	k	$18093 \div 119$	l	$87562 \div 2876$
- A box of Rellogs Pop Flakes weighs 375 grams.
What is the **approximate** weight of a carton containing 48 boxes of Pop Flakes ?

 -  A group of 37 workers in the Council offices won £77 900 in the Lotto draw.
Approximately, how much should each receive ?
 - The **average** yearly salary of a group of workers in a steel work was £18675.
If there were 388 workers, what was the **approximate** total yearly wage bill ?

Topic in a Nutshell

1. Write out the number 2 346 005 fully **in words**.



2. Write these numbers **using digits** :-

a four hundred and seven thousand eight hundred and fifty.

b $2\frac{1}{4}$ million.

3. Rearrange the numbers given below in order, starting with the **largest**.

4028 3982 4208 3892 4001 4010.

4. What numbers are represented by P and Q on the given scale ?

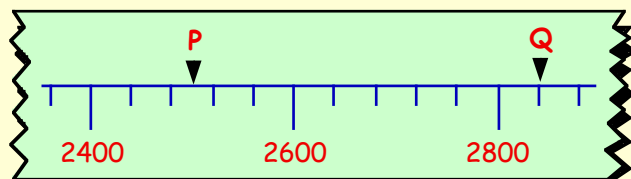

5. Try this question **mentally** :-

An aeroplane flew from Edinburgh to Madrid, via Amsterdam.

When the plane left Edinburgh there were 310 passengers on board.

70 got off the plane at Amsterdam and 46 boarded the plane there.

How many passengers were on board as the plane took off from Amsterdam ?

6. Attempt these problems, **showing all working** :-

a The attendance at two Seria A Italian football matches last Sunday were 46 320 and 38 985.

What was the total attendance for both games ?



b Colin made 1324 minutes of calls on his mobile phone last year. He was charged at the rate of 6 pence per minute.

What was his total phone bill for the year ?



c A group of 8 students worked part-time sealing envelopes for a mail order firm. In one hour they sealed 3368 envelopes altogether.

Assuming they each worked at the same rate, how many envelopes did each student seal in one hour ?

d



MacDavid's made 2174 Happy Meals last week. They sold 1986 of them.

How many had they left to throw out ?

7. What is :-

- a 105×10 b 100×147 c 1350×1000
d $81000 \div 10$ e $94500 \div 100$ f $2100000 \div 1000 ?$

8. a Fiona bought 20 packets of gum at 60 pence each.

How much did this cost her ?

b A shopkeeper bought in 400 pot noodles at 70 pence each.

How much did he pay ?

c A Cash & Carry owner bought 5000 litres of cola at 30p per litre.

What did she pay for all this juice ?

d There are 20 000 houses in Methil.

Before an election, 40 canvassers had to go round these houses.

If they split the work equally, how many houses did each canvasser visit ?

e The owner of a garden nursery planted 1200 rose bushes in rows of 30.

How many bushes will there be in each row ?

f The Thomson family won £81000 on the Lotto.

Each got an equal share of £9000.

How many people must there be in the Thomson family ?



9. A car is on sale at the local dealer's for £16 728.

Round this amount to the nearest :-

- a £10 b £100 c £1000.



10. Jenna is paying up her £6048 scooter over 48 months.

Round each number to 1 figure accuracy, then give an estimate for each monthly payment.



11. A luxury coach can seat 48 passengers.

How many coaches are needed to take 340 senior citizens on their annual trip ?



12. There is a certain number which, when you divide it by 2 or 3 or 4 or 5 or 6, gives a remainder of 1 each time, but when you divide it by 7, gives no remainder.

Can you find what this number could be ?

Chapter 2

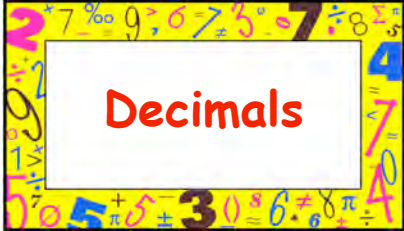

What is a Decimal ?

(A reminder)

In the whole number chapter, we looked at units, 10's, 100's, 1000's and large numbers.

When you take a single unit and divide it into 10 (or 100) bits, what we then have are **decimal fractions** of a whole number.

For example, if we take a standard bar of chocolate as our **"UNIT"** of measure,

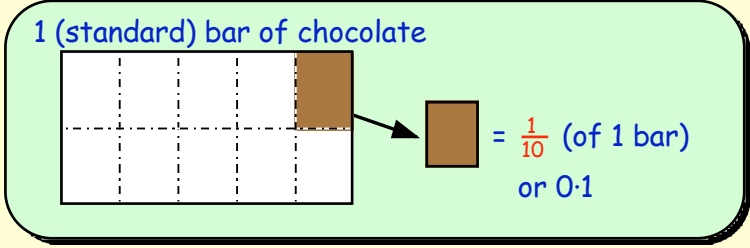

and if we divide it into 10 equal "bits", each bit is $\frac{1}{10}$ of the bar and is written as 0.1.

In the decimal number, 0.3, the "3" refers to **3 tenths** or $\frac{3}{10}$.

Exercise 1

1. In this question,  stands for 1 (whole number).

What do the following diagrams represent ?

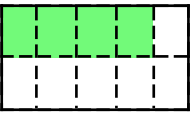
a 

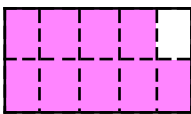
b 

c 

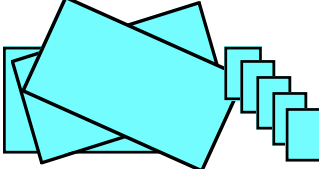
d 

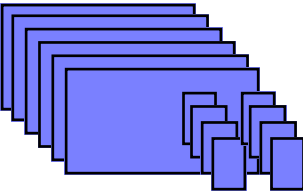
e 

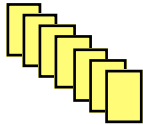
f 

2. Draw neat pictures, in the same style as shown above, to represent :-

- a 0.5
- b 1.6
- c 2.2
- d 6.7

3. Shown here is part of a circle (which had originally been divided into 10 sections).

What decimal number does the shaded part represent ?

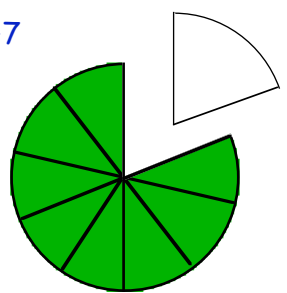

4. What numbers are represented in the following diagrams ?

a

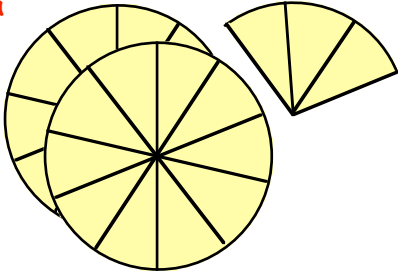

b

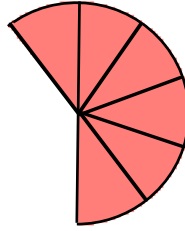

c

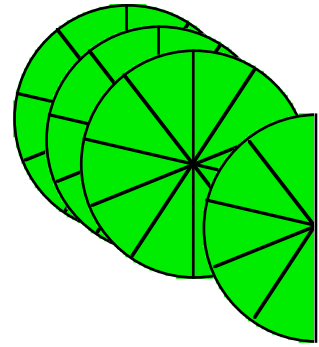

The Second Decimal Place

When our 1 bar of chocolate was divided into 10 pieces, each bit was called 1 tenth ($\frac{1}{10}$).

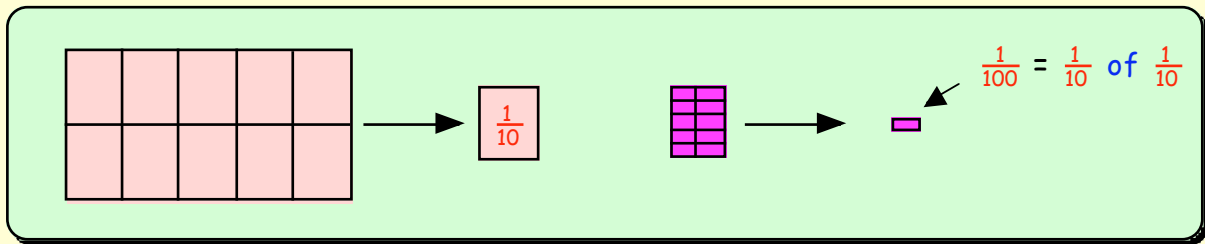

=> when a "tenth" is then cut into 10 equal bits each bit is ($\frac{1}{10}$ of $\frac{1}{10}$) = $\frac{1}{100}$.

In the decimal number, 0.07, the "7" refers to 7 hundredths or $\frac{7}{100}$.

5. What numbers are represented in the diagrams below ?

a

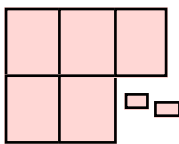

0.5...

b

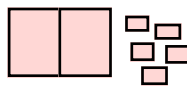

0.

c

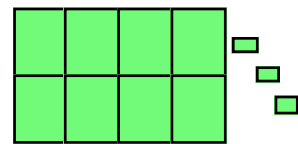

0.

d

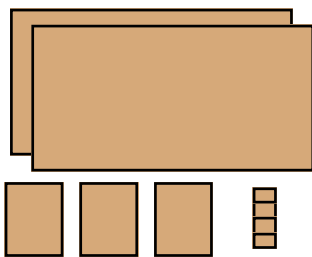

e

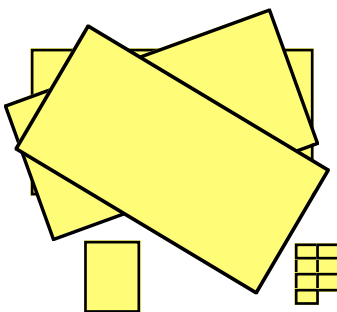

f



6. Draw neat pictures, similar to those above, to show the following decimal numbers :-

a 0.45

b 1.62

c 3.78

d 0.04

7. In the decimal number 13.47, what does the a 4 mean b 7 mean ?

8. What does the 6 stand for in each of these numbers :-

a 63.75

b 124.69

c 16.08

d 27.56 ?

The Third Decimal Place ... and beyond ?

Imagine that the small $\frac{1}{100}$ of the chocolate bar, (the \square), could be cut up into a further 10 equal pieces.

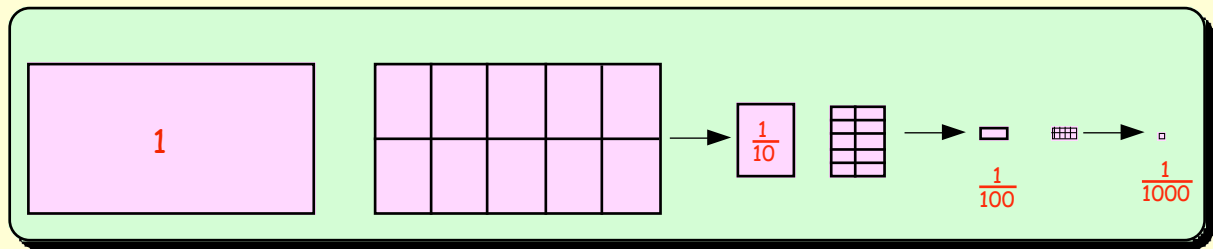

\Rightarrow Each piece would now be $(\frac{1}{10}$ of $\frac{1}{10}$ of $\frac{1}{10}) = \frac{1}{1000}$ (a thousandth).

In the decimal number, 0.008, the "8" refers to **8 thousandths** or $\frac{8}{1000}$.

9. In the decimal number 13.479, what does the :- a 7 mean b 9 mean ?
10. What does the **2** stand for in each of the following numbers :-
 a 324.153 b 9.026 c 0.254 d 209.533 e 4.062 ?
11. Arrange the following groups of numbers in order, **smallest** first :-
 a 0.98, 0.099, 1.001, 0.9, 1.090, 0.899, 0.009.
 b 0.076, 0.067, 0.008, 0.090, 0.077, 0.007, 0.107.
12. The number 2.365 can be thought of as follows :-

$$2.365 = 2 \text{ units} + \frac{3}{10} + \frac{6}{100} + \frac{5}{1000} \text{ or } 2 \text{ units} + \frac{365}{1000}$$
 Write the following decimals in the same **two** ways :-
 a 5.716 b 7.693 c 0.548 d 20.207 e 0.056
13. What number is :-
 a $\frac{3}{10}$ **up** from 2.6 b $\frac{5}{10}$ **down** from 8.2 c $\frac{7}{10}$ up from 6.91
 d $\frac{6}{100}$ up from 0.87 e $\frac{8}{100}$ down from 1.42 f $\frac{7}{100}$ up from 3.653
 g $\frac{3}{1000}$ up from 2.475 h $\frac{5}{1000}$ down from 0.971 i $\frac{9}{1000}$ down from 1.604 ?
14. What number is **half way** between 0.782 and 0.786 ?
15. What number lies **half way** between :-
 a 0.15 and 0.21 b 0.88 and 0.9 c 1.204 and 1.208
 d 0.090 and 0.096 e 0.001 and 0.007 f 2.315 and 2.325
 g 1.000 and 0.998 h 0.1 and 0.08 i 0.01 and 0.008 ?

Reading Decimal Scales

1 Decimal Place

Before saying which division an arrow is pointing to, decide firstly which 2 whole numbers it lies between.

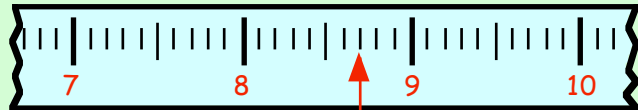

This arrow lies between 8 and 9.

It must be 8·(something).

It is in fact 8·7 (can you see this?)

Exercise 2

1. Say what number each of these arrows is pointing to :-

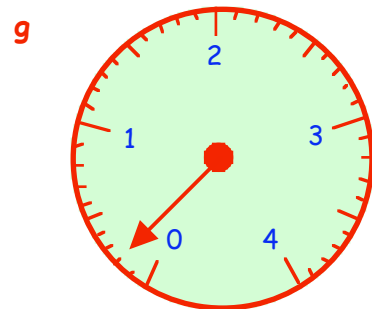
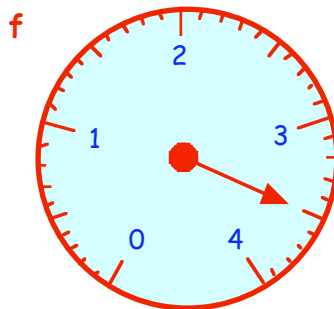
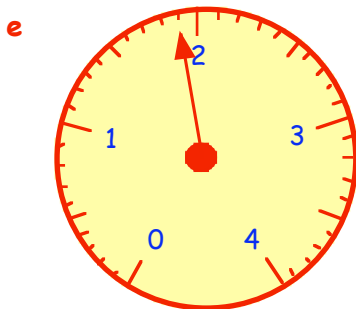
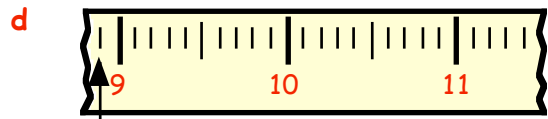
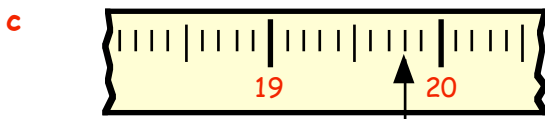
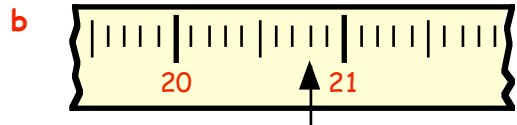
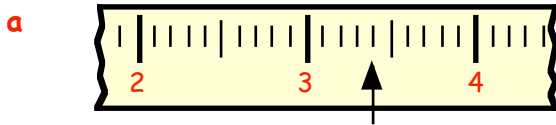

* careful here

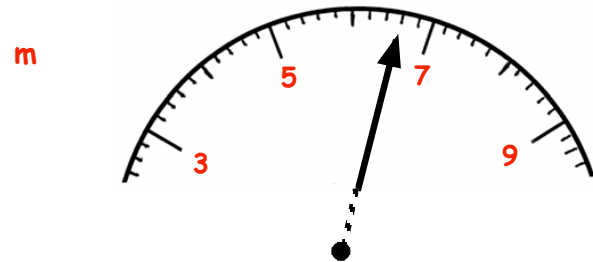
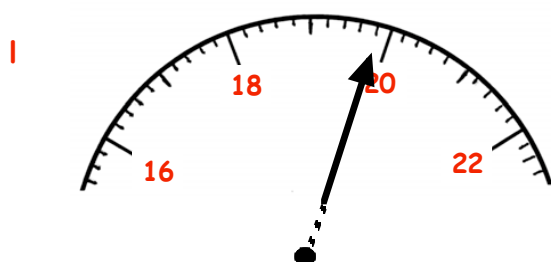
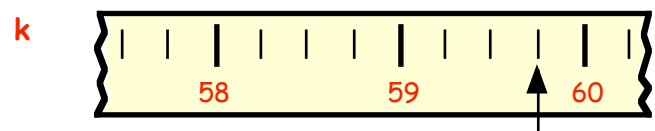
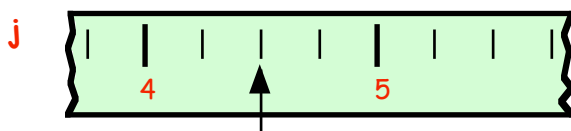
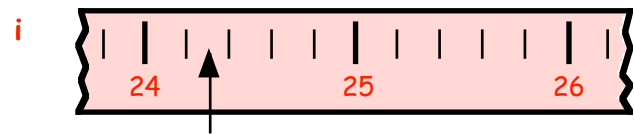
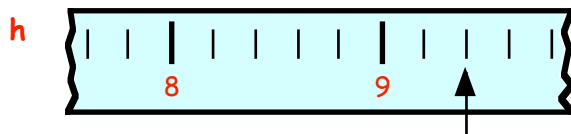

2 Decimal Places (Harder)

Firstly, look at the 2 numbers shown on the scale which lie either side of the arrow.
(the 4.5 and 4.6)

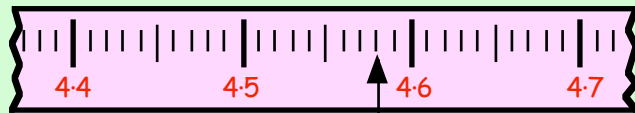

This arrow points to between 4.5 and 4.6.
It must be 4.5... (4.5 something).

It points to **4.58** (can you see this?)

2. To which numbers are each of the following arrows pointing :-

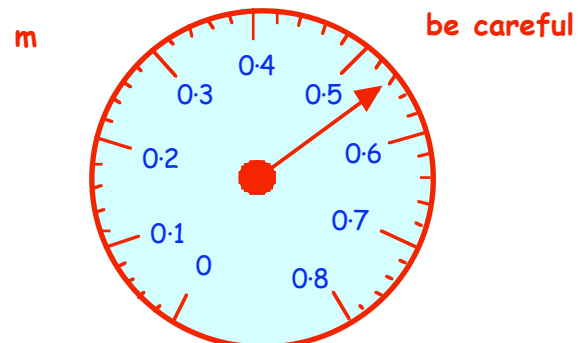
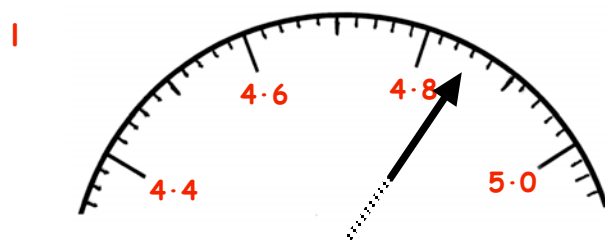
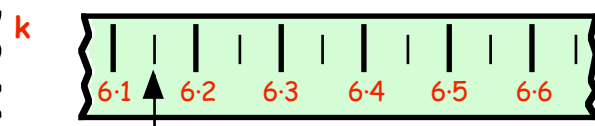
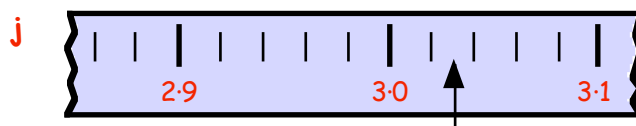
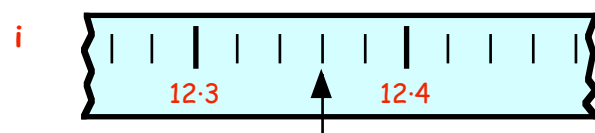
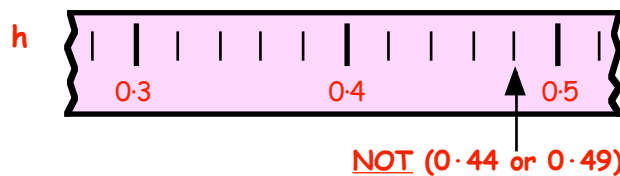
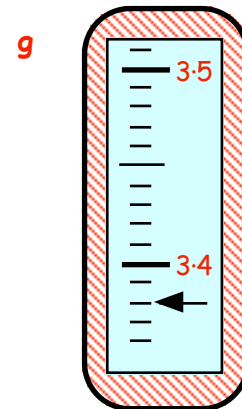
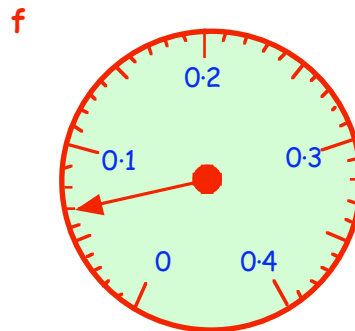
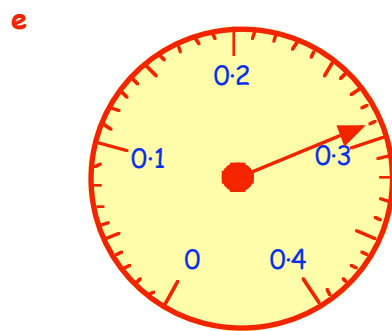
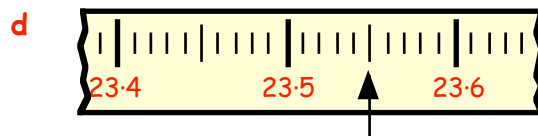
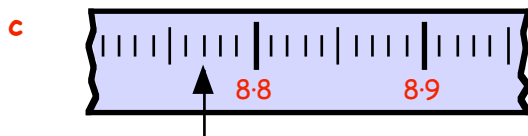
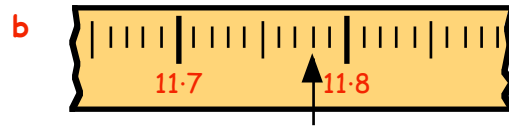
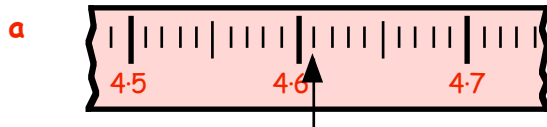

Rounding to 1 Decimal Place

8.26

lies between 8.2 and 8.3
It is closer to **8.3**,
(to 1 decimal place)

16.74

lies between 16.7 and 16.8
It is closer to **16.7**,
(to 1 decimal place)

When rounding to **1 decimal place** :-

=> look at the **2nd** decimal figure
if it is a 5, 6, 7, 8 or 9 => round your digit up by 1.
if it is a 0, 1, 2, 3 or 4 => leave your digit as it is.

Example :- Round 14.36 to 1 decimal place.

Answer :- Because of the 6 (in the 2nd decimal place), => round **up** to **14.4**.

Exercise 3

1. When each number is rounded to **1 decimal place**, which of the two values in the brackets is the correct answer :-

- | | |
|---------------------------------|------------------------------|
| a 4.47 (4.4 or 4.5) ? | b 6.82 (6.8 or 6.9) ? |
| c 3.06 (3.0 or 3.1) ? | d 0.88 (0.8 or 0.9) ? |
| e 15.75 (15.7 or 15.8) ? | f 2.96 (2.9 or 3.0) ? |
| g 10.04 (10.0 or 10.1) ? | h 0.09 (0.0 or 0.1) ? |
| i 6.99 (6.9 or 7.0) ? | j 5.55 (5.5 or 5.6) ? |

2. Copy and complete these statements :-

- | | |
|--|----------------------|
| a 8.47 lies between 8.4 and 8.5 . | It is closer to |
| b 5.82 lies between 5.8 and | It is closer to |
| c 3.58 lies between ... and | It is closer to |
| d 1.24 lies between ... and | It is closer to |
| e 2.03 lies between ... and | It is closer to |
| f 0.69 lies between ... and | It is closer to |
| g 7.85 lies between ... and | It is closer to |
| h 0.13 lies between ... and | It is closer to |
| i 9.96 lies between ... and | It is closer to |

To round numbers like 5.76136 to 1 decimal place :-

Step 1 - check that it lies between 5.7 and 5.8

Step 2 - decide which number it is closer to → **5.8**

3. Round these numbers to 1 decimal place, in the way shown above :-

a $3.42528 \rightarrow 3.4$

b $2.87883 \rightarrow 2.9$

c $8.39599 \rightarrow 8.4$

d $9.43691 \rightarrow 9.4$

e $5.04808 \rightarrow 5.0$

f $4.05126 \rightarrow 4.1$

g $12.88791 \rightarrow 12.9$

h $0.34678 \rightarrow 0.3$

i $0.07834 \rightarrow 0.1$

4. You should use your calculator to do the following divisions, then write down the answers correct to 1 decimal place :-

a $80 \div 14$

b $300 \div 29$

c $10.7 \div 0.85$

d $215 \div 38.6$

e $0.76 \div 0.18$

f $1000 \div 186.7$



5. You will discover later that if you wish to change a fraction to a decimal, you **divide**.

$\frac{3}{7}$ means $3 \div 7 = 0.428571428 \dots = 0.4$ (to 1 decimal place)

Use your calculator to change these fractions to decimals and round your answers to 1 decimal place :-

a $\frac{5}{7} = (5 \div 7) = 0.7142857 \dots = 0.7$ (to 1 decimal place)

b $\frac{6}{11} = (6 \div 11) = 0.545454 \dots = 0.5$

c $\frac{7}{9} = (7 \div 9) = 0.777777 \dots = 0.8$

d $\frac{11}{13} = 0.846153 \dots = 0.8$

e $\frac{4}{15} = 0.266666 \dots = 0.3$

f $\frac{13}{16} = 0.8125 = 0.8$

g $\frac{14}{17} = 0.823529 \dots = 0.8$



6. We can estimate answers by rounding to 1 decimal place. First, round each number to 1 decimal place, (no calculator) and find an estimate to :-

$3.876 + 2.139$
 $= 3.9 + 2.1 = 6.0$

a $6.287 + 2.539$

b $19.605 + 4.277$

c $8.731 - 2.599$

d $0.897 + 3.642$

e $11.888 - 7.629$

f $2.387 + 0.775$

g $0.945 - 0.687$

h $4.84 + 3.296$

i $5.073 - 2.891$

7. a A piece of rope, 17.3 metres long, is cut into 6 pieces of equal length.

What length will each part be (to 1 decimal place) ?

b 9.7 litres of oil are poured in equal amounts into 8 cans.

How much oil will there be in each can (to 1 decimal place) ?

c 12 workers share a lottery win of £17 470.

How much should each receive, to the nearest 10 pence (1 decimal place) ?



Add/Subtract Decimals

When you add or subtract decimal numbers, it is important to **line up the decimal points**.

Example :-

To add 7.8 and 0.92 =>

$$\begin{array}{r} 7.8 \\ + 0.92 \\ \hline 8.72 \\ \hline 1 \end{array}$$

Exercise 4

1. Try to do the following **mentally**. Just write down the answers to :-



- | | | | | | | | |
|----------|-------------|----------|-------------|----------|-------------|----------|-------------|
| a | 6.5 + 8.3 | b | 4.5 + 5.4 | c | 3.7 + 7.6 | d | 9.2 + 1.3 |
| e | 0.54 + 0.36 | f | 0.26 + 0.52 | g | 0.47 + 0.47 | h | 0.22 + 0.88 |
| i | 5.3 + 0.24 | j | 7.1 + 0.65 | k | 4.7 + 0.82 | l | 8.8 + 0.35 |
| m | 6.9 - 3.5 | n | 8.7 - 1.6 | o | 9.2 - 0.8 | p | 7.5 - 0.7 |
| q | 5.8 - 2.9 | r | 5.6 - 1.8 | s | 0.67 - 0.35 | t | 0.97 - 0.46 |
| u | 0.72 - 0.08 | v | 0.63 - 0.29 | w | 5 - 0.84 | x | 3 - 0.61 |

2. Do the following **mentally** :-

- a** An empty pan weighs 2.7 kilograms. 3.6 kilograms of mince is placed in the pan. What is the combined weight ?



- b** Of the 7.6 kilometres from his home to school, Davie has already cycled 2.9 kilometres. How much further has Davie still to cycle ?

- c** A metal strengthener (L shaped) is shown. The straight edges measure 8.9 cm and 7.4 cm. What would the length be if the L shape was totally flattened out ?

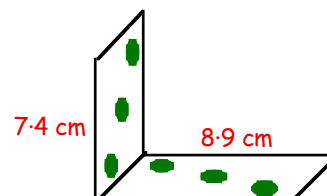

- d**  The three judges in the skating competition gave Anita scores of 9.3, 8.8 and 9.0. What was Anita's **total** score ?

- e** Of the 0.95 litres of water left outside, 0.67 litres evaporated in the hot sun. What volume of water was left ?

- f** Geraldine walks 3.8 km from her home to the Supermarket. She then walks 1.9 km to the optician before travelling the 4.6 km back home. How far has Geraldine walked **altogether** ?



3. Copy the following and find :- (no calculator)

$$\begin{array}{r} \text{a} \quad 39.5 \\ + 48.3 \\ \hline \end{array}$$

$$\begin{array}{r} \text{b} \quad 38.19 \\ + 27.44 \\ \hline \end{array}$$

$$\begin{array}{r} \text{c} \quad 62.95 \\ + 38.77 \\ \hline \end{array}$$

$$\begin{array}{r} \text{d} \quad 9.87 \\ + 16.48 \\ \hline \end{array}$$

$$\begin{array}{r} \text{e} \quad 5.28 \\ - 3.46 \\ \hline \end{array}$$

$$\begin{array}{r} \text{f} \quad 50.46 \\ - 29.53 \\ \hline \end{array}$$

$$\begin{array}{r} \text{g} \quad 32.47 \\ + 68.89 \\ \hline \end{array}$$

$$\begin{array}{r} \text{h} \quad 52.84 \\ - 38.76 \\ \hline \end{array}$$

$$\begin{array}{r} \text{i} \quad 10.00 \\ - 7.32 \\ \hline \end{array}$$

$$\begin{array}{r} \text{j} \quad 53.65 \\ + 37.8 \\ \hline \end{array}$$

$$\begin{array}{r} \text{k} \quad 60.46 \\ - 29.9 \\ \hline \end{array}$$

$$\begin{array}{r} \text{l} \quad 2.00 \\ - 0.65 \\ \hline \end{array}$$

$$\text{m} \quad 26.4 + 35.9$$

$$\text{n} \quad 46.2 - 27.5$$

$$\text{o} \quad 9.83 + 7.74$$

$$\text{p} \quad 8.25 - 3.96$$

$$\text{q} \quad 26.88 + 17.93$$

$$\text{r} \quad 133.75 + 219.74$$

$$\text{s} \quad 16.7 + 0.86$$

$$\text{t} \quad 45.1 - 8.23$$

$$\text{u} \quad 16 - 2.7$$

$$\text{v} \quad 10.9 - 9.87$$

$$\text{w} \quad 4 - 0.73$$

$$\text{x} \quad 0.9 - 0.07$$

4. Show all your working whilst attempting the following :-

a Jenny weighs 61.83 kilograms and Francis weighs 56.49 kilograms.

- (i) What is their combined weight ?
- (ii) By how much is Jenny **heavier** than Francis ?



b Look at this plan of a L-shaped living room.

- (i) Calculate the length of the room (marked x metres).
- (ii) Calculate the value of y.

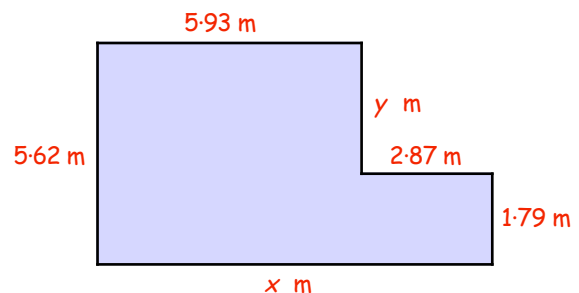

c



The van in this figure weighs 375.2 kg. A carton weighs 8.76 kg.

What is the combined weight of :-

- (i) the van plus 1 carton ?
- (ii) the van plus 3 cartons ?

5. A **magic square** is one in which the 3 numbers in each row, column and diagonal add to the same amount.

- a What must the **total** be each time in this magic square ?
- b Copy and complete the magic square.

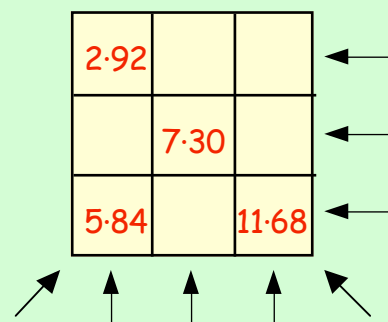

6. You may use a calculator here, but show all your working :-



a 3 boxes weigh 2.813 kg, 4.936 kg and 3.709 kg.

(i) What is the combined weight of the 2 lightest boxes ?

(ii) What is the total weight of all 3 boxes ?

(iii) By how much is the heaviest box heavier than the lightest box ?

b A small truck weighs 450.85 kg. It carries washing machines. Each washing machine weighs 53.57 kg.

What is the combined weight of :-

(i) the truck carrying 1 washing machine ?

(ii) the truck with a full load of 6 washing machines ?



c



A vase contained exactly 3 litres of water. During a hot spell of weather, 0.465 litres of water evaporated.

How much water was left in the vase ?

d A metal rod is 1.987 metres long. When heated it expands to 2.043 metres.

By how much has the rod expanded ?

e Brendan ran the 100 metre race in 10.057 seconds.

Justin ran it in 9.968 seconds.

By how much did Justin beat Brendan in the race ?



7. This map shows the distance between 4 towns.

The distance from Alsop to Brie is 3.015 km.

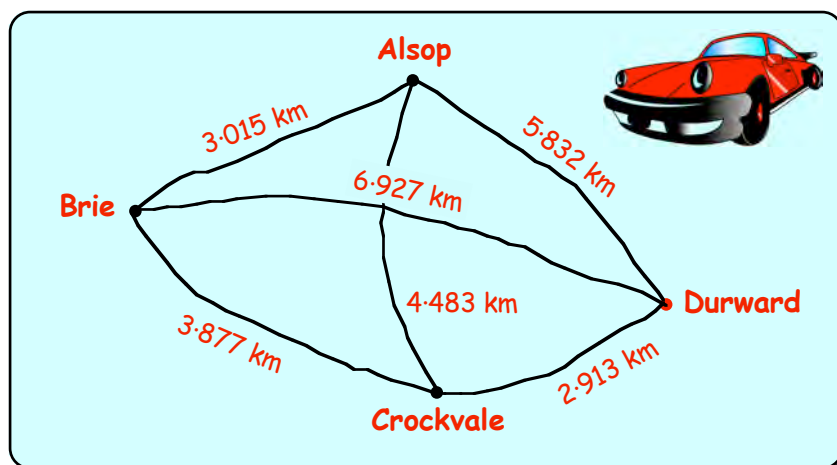

a How much **further** is it to drive from Brie to Durward via Alsop than to drive directly from Brie to Durward ?

b How much **further** is it to drive from Alsop to Crockvale via Durward than via Brie ?

c Billy the butcher drove from Brie → Alsop → Durward → Crockvale → back to Brie. How far had he travelled **altogether** ?

Multiply and Divide Decimals

Yet again, you **really must know your tables !!!!!**

Multiplication by 10, 100, 1000

Learn the following **simple rules for decimals** :-

If you multiply by 10,

=> move all the figures **ONE place LEFT**
(or move the point one place right)

$$\begin{array}{r} 7.86 \\ \times 10 \\ \hline 78.6 \end{array}$$

If you multiply by 100,

=> move all the figures **TWO places LEFT**
(or move the point two places right)

$$\begin{array}{r} 14.726 \\ \times 100 \\ \hline 1472.6 \end{array}$$

If you multiply by 1000,

=> move all the figures **THREE place LEFT**
(or move the point three places right)

$$\begin{array}{r} 28.3056 \\ \times 1000 \\ \hline 28305.6 \end{array}$$

Exercise 5



1. Write down the answers to the following :-

- | | | | |
|----------------------|---------------------|---------------------|----------------------|
| a 2.8×10 | b 5.6×10 | c 3.41×10 | d 10×8.32 |
| e 10×11.87 | f 0.86×10 | g 10×3.09 | h 10×0.06 |
| i 19.865×10 | j 8.302×10 | k 10×1.006 | l 0.0407×10 |

2. Write down the answers to :-

- | | | | |
|----------------------|----------------------|-----------------------|-----------------------|
| a 3.82×100 | b 7.64×100 | c 100×1.07 | d 100×6.4 |
| e 4.256×100 | f 100×0.851 | g 100×0.0461 | h 0.0025×100 |

3. Write down the answers to :-

- | | | | |
|-----------------------|------------------------|------------------------|------------------------|
| a 1.832×1000 | b 2.070×1000 | c 3.92×1000 | d 1000×14.1 |
| e 1000×0.917 | f 0.0835×1000 | g 1000×1.0101 | h 1000×0.9004 |

4. A bag of sugar weighs 2.2 pounds. What is the weight of

- | | | |
|-----------|------------|---------------|
| a 10 bags | b 100 bags | c 1000 bags ? |
|-----------|------------|---------------|



5. There are 1000 metres in 1 kilometre. How many metres are there in :-

- | | | | |
|------------|-----------|----------|--------------|
| a 2.534 km | b 19.6 km | c 0.8 km | d 0.004 km ? |
|------------|-----------|----------|--------------|

Division by 10, 100, 1000

Learn the following **simple rules for decimals** :-

If you divide by 10,

=> move all the figures **ONE place RIGHT**
(or move the point one place left)

$$\begin{array}{r} 1.38 \\ 10 \overline{) 13.8} \end{array}$$

If you divide by 100,

=> move all the figures **TWO places RIGHT**
(or move the point two places left)

$$\begin{array}{r} 2.178 \\ 100 \overline{) 217.8} \end{array}$$

If you divide by 1000,

=> move all the figures **THREE places RIGHT**
(or move the point three places left)

$$\begin{array}{r} 0.3096 \\ 1000 \overline{) 309.6} \end{array}$$

Exercise 6



1. Write down the answers to the following :-

- | | | | |
|-------------------|--------------------|-------------------|-------------------|
| a $18.2 \div 10$ | b $26.9 \div 10$ | c $4.84 \div 10$ | d $326.5 \div 10$ |
| e $19.82 \div 10$ | f $135.27 \div 10$ | g $14.02 \div 10$ | h $17 \div 10$ |
| i $9 \div 10$ | j $0.86 \div 10$ | k $0.4 \div 10$ | l $0.043 \div 10$ |

2. Do the following :-

- | | | | |
|--------------------|---------------------|-------------------|--------------------|
| a $923.4 \div 100$ | b $865.12 \div 100$ | c $64.8 \div 100$ | d $19.04 \div 100$ |
| e $620 \div 100$ | f $831 \div 100$ | g $9.6 \div 100$ | h $0.2 \div 100$ |

3. Do the following :-

- | | | | |
|----------------------|-----------------------|--------------------|---------------------|
| a $7364.1 \div 1000$ | b $29653.2 \div 1000$ | c $8260 \div 1000$ | d $725.1 \div 1000$ |
| e $420 \div 1000$ | f $900 \div 1000$ | g $81.2 \div 1000$ | h $17 \div 1000$ |

4. a When 100 drawing pins are weighed, their total weight is 35.1 grams.
What is the weight of 1 drawing pin ?

b 10 people form a group who get 4 numbers up in the lottery.
Their winnings come to £78.50. How much will each person receive ?

5. There are 1000 grams in 1 kilogram. How many kilograms are there in :-

- | | | | |
|--------------|---------------|--------------|---------------|
| a 1528 grams | b 626.7 grams | c 94.4 grams | d 7.5 grams ? |
|--------------|---------------|--------------|---------------|

6. 96.7 millilitres of a chemical is poured equally into 100 small phials.
How much chemical should go into each phial ?

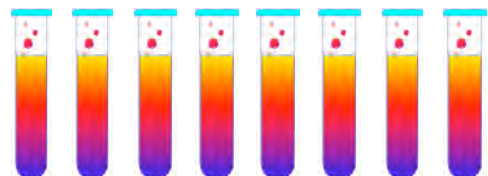

Multiplication by a Single Digit

Those tables **AGAIN** ???

Example 23.68×7

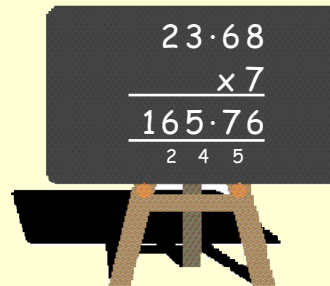

note that
the point
stays in line

Exercise 7

1. Copy the following and complete the calculations :-

a
$$\begin{array}{r} 4.32 \\ \times 4 \\ \hline \\ \hline \end{array}$$

b
$$\begin{array}{r} 5.98 \\ \times 2 \\ \hline \\ \hline \end{array}$$

c
$$\begin{array}{r} 17.3 \\ \times 5 \\ \hline \\ \hline \end{array}$$

d
$$\begin{array}{r} 42.64 \\ \times 7 \\ \hline \\ \hline \end{array}$$

e
$$\begin{array}{r} 40.67 \\ \times 8 \\ \hline \\ \hline \end{array}$$

f
$$\begin{array}{r} 120.12 \\ \times 9 \\ \hline \\ \hline \end{array}$$

g
$$\begin{array}{r} 456.3 \\ \times 3 \\ \hline \\ \hline \end{array}$$

h
$$\begin{array}{r} 112.83 \\ \times 6 \\ \hline \\ \hline \end{array}$$



2. Rewrite each of these in the above form and complete the calculations :-

a 7.8×6

b 15.3×4

c 7.64×5

d 13.87×9

e 8×20.46

f 3×9.39

g 112.4×7

h 6×205.13

3. Show your working in answering the following questions :-

a A packet of crisps weighs 26.7 grams.
What is the weight of 6 packets ?

b Jamie is paid £13.75 per day as a strawberry picker. How much will he earn altogether working each day from Monday to Friday ?

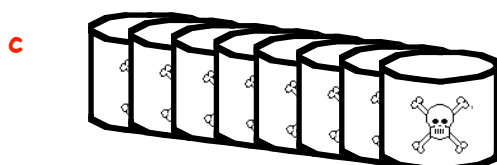
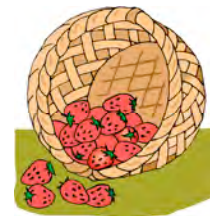

c A canister holds 16.35 litres of acid.
How much acid will there be in 8 canisters ?

d By how much is 7×0.96 bigger than 8×0.83 ?

e It says on the packet that the grass food will cover 12.8 m² of lawn.
How much lawn can be treated with 9 packets ?



f A tortoise covered 18.26 metres in the space of 1 hour. At this speed, how far will it travel in 6 hours ?



g During a storm, 2.34 centimetres of rain fell every hour.
What depth of rain fell during the 8 hours the storm lasted ?



Division by a Single Digit

TABLES ?

Example $17 \cdot 16 \div 6$

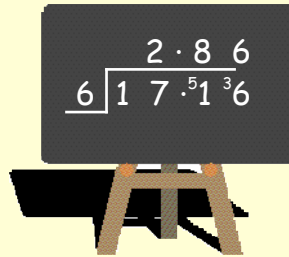

note that
the point
stays in line

Exercise 8



1. Copy the following and complete the calculations :-

- a $2 \overline{)15 \cdot 36}$ b $4 \overline{)29 \cdot 44}$ c $3 \overline{)40 \cdot 74}$ d $8 \overline{)89 \cdot 12}$
 e $5 \overline{)4 \cdot 85}$ f $7 \overline{)0 \cdot 84}$ g $6 \overline{)112 \cdot 74}$ h $9 \overline{)60 \cdot 03}$

2. Rewrite each of these in the above form and complete the calculation :-

- a $7 \cdot 8 \div 6$ b $16 \cdot 8 \div 3$ c $9 \cdot 64 \div 2$ d $44 \cdot 38 \div 7$
 e $1 \cdot 84 \div 8$ f $91 \cdot 02 \div 6$ g $526 \cdot 8 \div 4$ h $0 \cdot 81 \div 9$

3. Show your working in answering the following questions :-

- a 8 packets of sweets weigh 385.6 grams.
What is the weight of 1 packet ?
 b Tony is paid £44.94 for working
7 hours as a barman.
How much does he earn each hour ?
 c I walked 23.45 kilometres in 5 hours.
How far had I travelled, on average, each hour ?



- d I bought 6 lengths of fencing to surround my garden.
The total length of the 6 pieces together was 11.76 metres.
What was the length of each piece of fencing ?

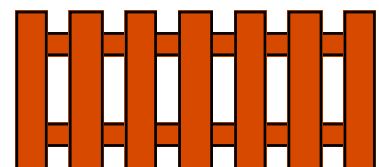

- e To find a "quarter" of anything, you simply **divide by 4**.
 (i) What is a quarter of 39.56 ? (ii) What is a third of 17.88 ?
 (iii) What is a sixth of 50.04 ? (iv) What is a fifth of 106.25 ?
 (v) What is a ninth of 76.05 ? (vi) What is an eighth of 1.92 ?

f



A sign in a supermarket claimed that no more than one seventh of their mince was fat.
If a packet of mince weighed 2.52 kg, how much of it, at most, should be fat ?

Mixed Problems

In this exercise, you must decide whether to **add**, **subtract**, **multiply** or **divide**.

You **MAY** use a calculator, but **MUST** show what type of calculation you are doing.

Exercise 9



1. I bought 7.5 metres of velvet curtain material at £12.54 per metre.

How much did the material cost ?



2.  If three glasses, holding 0.783, 0.96 and 1.056 litres of water are poured into a bowl, how much water will there be altogether ?

3. James has an annual salary of £10 634 and gets paid weekly.

How much does he earn per week ?

4. Mr. Leishman took his two sons to a football match at Station Park. It cost £10.50 for himself and £6.30 for each of his sons.

What was the total cost ?



5. Charles pays £153.30 for 6 months of Broadband on his computer.

What is the cost for each month ?

6. The cost of a new Volvo starts at £14 300.50.
The cost of a new Kia starts at £5995.99.

What is the difference in price between the two cars ?



7. Jane hires a suite cleaning machine from the local store. It costs her £5.50 deposit plus £3.25 per hour.

She returned the machine after 5 hours use.

How much had she to pay ?



8. Music Ltd. are selling packs of 20 blank CD's for £16.
McCurry's are selling the same blank CD's in packs of 50 for £39.

Which store is cheaper per CD, and by how much ?



9. Mark buys a round of eight drinks, each costing £1.62, five packets of nuts at 75p each and three packets of crisps at 40p each.

What change does he get from £20 ?



10. A group of 14 former pupils of Kilsyth Academy met up for a reunion dinner. The total cost of the meal came to £353.50, which they split equally.
How much did each have to pay ?

11. The times of the five fastest runners in a school's sports event were :-
28.76 secs 30.12 secs 31.34 secs 31.71 secs 32.57 secs

Calculate the average time taken by these five runners.
(add the 5 times together, then divide your answer by 5).



12. a Calculate the **total** sale price of this home entertainment system.
b If the normal price for the package containing all three items was £1199.99, how much would I save in the sale ?

Sale	
32" Flat Screen TV	£861.50
DVD Player	£214.40
Video	£86.75

13. Jacob drinks 0.15 litres of juice from a 1 litre carton.
a How much juice is left in the carton ?
b His young sister then pours two lots of 0.28 litres from the carton.
How much juice is left in the carton now ?



14. The perimeter of this shape is 27.3 metres.
Calculate the length of the missing side.

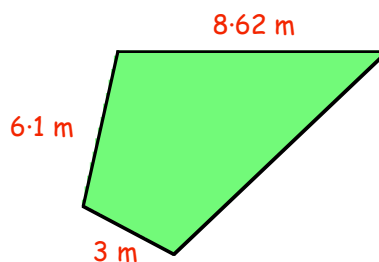

15. A cardboard box weighs 1.235 kg when empty. Each can weighs 0.525 kg.

What is the combined weight of a box containing 24 cans ?



16. A tortoise began to walk along a straight path. In the first hour, it walks 8.465 metres. Every hour after that, as it tires, it walks half the distance it walked in the previous hour.
How far will it have walked **altogether** in 6 hours ?



Topic in a Nutshell

1. What decimal number is represented by this diagram ?

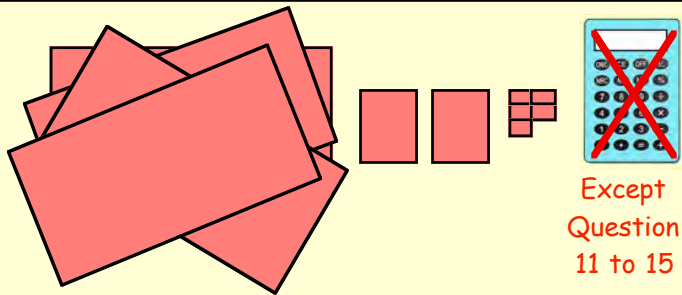

Except
Question
11 to 15

2. In the decimal number 59.247 what does the :-
 a 2 stand for ? b 4 stand for ? c 7 stand for ?
3. Which numbers are the arrows pointing to in the following scales ?

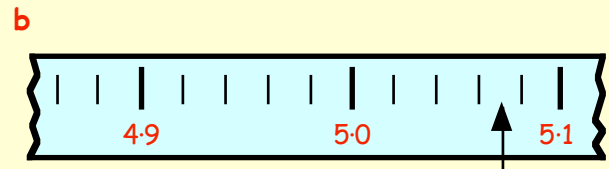
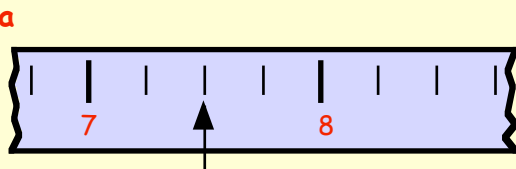

4. Round the following to one decimal place :-
 a 2.374 b 23.948 c 4.582111 d $32.45 \div 3$
5. Write down the answers to :-
 a $0.11 + 0.75$ b $5.1 + 0.35$ c $9.4 - 1.6$ d $7 - 0.63$
6. Copy the following and find :-
 a $35.74 + 19.87$ b $9 - 0.81$ c $5.762 + 2.875$ d $9.418 - 6.783$
 e 57.2×6 f 0.47×9 g $29.6 \div 4$ h $0.624 \div 8$
7. Round each number to one decimal place and then estimate the following :-
 a $3.47 + 5.82$ b $6.428 + 1.257$ c $9.783 - 6.403$ d $4.847 - 3.993$
8. Write down the answers to :-
 a 0.53×10 b 10×24.247 c 100×0.123 d 6.9×100
 e 0.5002×1000 f 1000×2.87 g $27.1 \div 10$ h $0.75 \div 10$
 i $870 \div 100$ j $1.23 \div 100$ k $4870 \div 1000$ l $26.1 \div 1000$
9. How much change from a £5 note will I receive if I buy a magazine at £1.75 and a can of juice at 53 pence ?

10. On a shopping trip, Janice Baker bought a pair of jeans for £30.25, a polo shirt for £24.99 and a baseball cap for £2.67.



If she handed 3 twenty pound notes to the shop assistant how much change should she receive ?

11.



One tin of creosote paint covers 9 square metres of fencing.

- a How many tins will I need for a fence with an area of 102.5 square metres ?

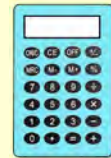

questions 11-15

- b At £6.50 per tin, what will I have to pay ?

12. Mr Arnold bought a new set of 4 tyres for £174.40.

What was the cost of 1 tyre ?



13.

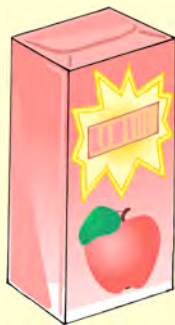

A carton of apple juice contains 1.485 litres.

A supermarket orders 55 cartons from the manufacturer.

How many litres of juice is this ?

(Round your answer to 1 decimal place)

14. Dick Coulthard finds that he can travel 602.5 miles on 12.5 gallons of petrol.

How many miles to the gallon is he getting ?



15. Laser Computers are selling boxes of 30 disks for £2.16. Print Out Computers are selling disks in tubs of 200 for £14.60

Which computer shop is more expensive per disk and by how much ?

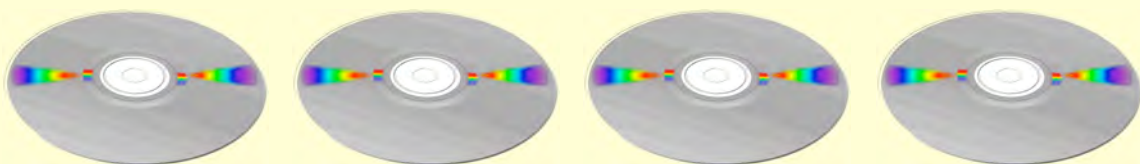

Chapter 3



Time

12 hour time → 24 hour time
24 hour time → 12 hour time

Revision of Level D time work.

Exercise 1

1. **Reminder :-**

7:15 am → 0715 3:35 pm → 1535

Change the following 12 hour clock times to **24 hour clock times** :-

- | | | | | | |
|---|----------|---|----------|---|----------|
| a | 7:40 am | b | 2:55 am | c | 3 am |
| d | 2:30 pm | e | 1:15 pm | f | 7 pm |
| g | 4:45 am | h | 9:20 pm | i | 3:35 am |
| j | 8:55 am | k | noon | l | 12:10 am |
| m | 12:10 pm | n | 8:30 pm | o | 2:55 am |
| p | 11:10 pm | q | 10:32 pm | r | 6:36 am |
| s | 11:58 pm | t | 11:13 am | u | 7:48 pm |



2. **Reminder :-**

0615 → 6:15 am 2015 → 8:15 pm

Change the following 24 hour clock times to **12 hour clock times** :-

- | | | | | | |
|---|------|---|------|---|------|
| a | 0230 | b | 1050 | c | 0810 |
| d | 1435 | e | 1650 | f | 2335 |
| g | 0130 | h | 1735 | i | 2010 |
| j | 1702 | k | 1200 | l | 0650 |
| m | 0345 | n | 1525 | o | 2345 |
| p | 2105 | q | 0040 | r | 0505 |
| s | 1125 | t | 1840 | u | 2248 |



Time Intervals, Timetables, Programme Guides

Counting on :- The easiest way of finding how long something lasts is by "counting on".

Example :- A show starts at 7:25 pm and ends at 10:15 pm. How long was the show ?

Answer :-

$$\begin{array}{ccccccc}
 & & 35 \text{ mins} & + & 2 \text{ hours} & + & 15 \text{ mins} & = & 2 \text{ hrs } 50 \text{ mins} \\
 & \text{7:25 pm} & \rightarrow & \text{8:00 pm} & \rightarrow & \text{10:00 pm} & \rightarrow & \text{10:15 pm} & \\
 \end{array}$$

Exercise 2

1. How long is it from :- (show how you used "counting on" to obtain your answer)

- | | |
|---|--|
| <p>a 2:05 pm to 5:05 pm</p> <p>c midday to 4:30 pm</p> <p>e 6:55 am to 8:25 am</p> <p>g 0720 to 0925</p> <p>i 1850 to 2005</p> | <p>b 9 am to 11:30 am</p> <p>d 7:30 pm to 10:35 pm</p> <p>f 3:40 am to 9:15 am</p> <p>h 1755 to 1920</p> <p>j 2250 to 0200 (next day ?)</p> |
|---|--|

2. Calculate the **finishing times** of the following concerts :-

	a	b	c	d	e
Start Time	2:30 pm	4:45 pm	7:35 pm	11:45 am	10:30 pm
Show lasted	1 hr 30 mins	2 hr 20 mins	2 hr 45 mins	55 mins	3 hr 35 mins

3. The two clocks show when a concert started and finished one Saturday afternoon.

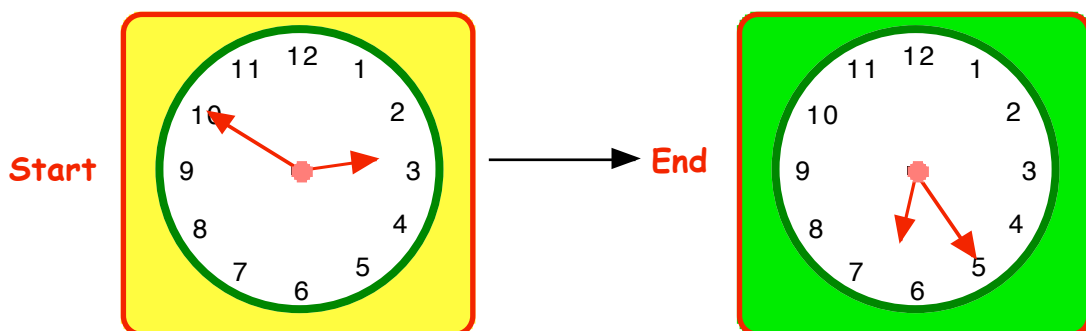

For **how long** did the concert last ?

4. Davie set off on the Auchtermuchty Marathon at 9:35 am. He arrived, (exhausted) at the finish line at 1:12 pm. **How long** had Davie taken to run the marathon ?



5. Shown is part of the bus timetable from Slough to Plassy.

	Slough	Digby	Hove	Drail	Plassy
Early Bus	7:05 am	8:10 am	10:20 am	11:05 am	1:40 pm
Late Bus	11:15 am	12:20 am			5:50 pm

- a How long does the early bus take to travel from :-
- (i) Slough to Digby ? (ii) Hove to Drail ? (iii) Slough to Plassy ?
- b Assuming that the late bus travels at the same speed as the early bus, when would it be expected to arrive at :-
- (i) Hove ? (Hint ! Notice how long the early bus takes from Digby to Hove)
- (ii) Drail ?



6.



A fishing boat leaves Arbroath Harbour at 5:45 am and does not return till quarter to 5 at night. For how long had the boat been at sea ?

7. A plane leaves Heathrow Airport at 2250 on Friday. It touches down in Florida at 0435 (British time) on Saturday. How long did the flight take ?



8. A satellite circles the earth. At 0235 it is directly above Glasgow. It is then found to be above Glasgow again at 0610.

- a Calculate the time taken for 1 complete orbit of earth.
- b When would you next expect the satellite to be over Glasgow ?
- c How many **complete** orbits will it make in a day ?



9.



There's a bricklayer's competition to see who can build a wall made of 1000 bricks the quickest. Mick started at 0945 and completed his wall at 1405. Pat began to build his at 1250 and finished at 1705. Who was quicker and by how much ?

Minutes, Seconds and Decimals

Minutes & Seconds

For accuracy, especially in sport, time is measured in minutes and seconds and the seconds are sometimes measured to 1 or 2 decimal places.



stopwatch

Exercise 3

1. Round the following times to **1 decimal place** :-

a 8.76 secs

b 9.03 secs

c 10.58 secs

d 15.84 secs

e 20.16 secs

f 2.61 secs

g 3.284 secs

h 11.888 secs

i 0.155 secs

2. Here are the times for 6 runners in a 400 metre race :-

Derby - 44.36 secs

Newlands - 45.45 secs

Hartley - 43.87 secs

Dixon - 45.54 secs

Bryant - 44.09 secs

Stuart - 45.18 secs

List the 6 runners in order, **winner first**.

3. Here are the individual times for each of the 4 runners in the British team in the four by 200 metre relay race.

Smith - 21.89 secs, **Jones** - 22.23 secs, **Davies** - 22.64 secs, **Nixon** - 21.9 secs

Calculate the **total** time for the 800 metre race.

(Give your answer in minutes and seconds).

4. Here are the times for the 4 Russian runners :-

Ruska - 22.56 secs, **Tolsky** - 21.86 secs, **Vladka** - 22.5 secs, **Namkov** - 21.96 secs

Calculate the total time for the Russian 800 metre race. Which team was faster ?

5. At the Olympic games in Seoul in 1988, Ben Johnston, of Canada, ran the men's 100 metre race in 9.78 seconds followed by Donovan Bailey in 9.84 seconds. By how much did Johnston beat Bailey ?

(Johnston lost the title when he tested positive for drugs - so Bailey won).

6. The world indoor record for the men's 5000 metre race was 13 minutes, 6.58 seconds.

On 20th February, Haile Gebrselassie from Ethiopia managed to take 7.54 seconds off this time to create a new world record. What was Haile's time ?



7. This stopwatch shows the time in minutes and seconds.

The time shown is 3 minutes 14.25 seconds.

State the times which are shown on the following stopwatches :-

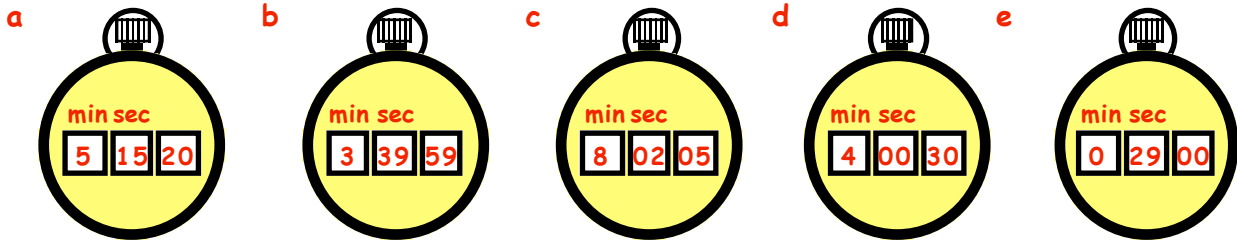
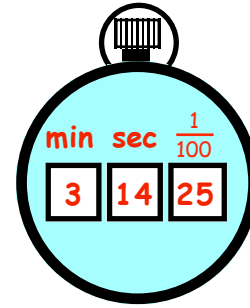

8. For longer races, like a marathon, stopwatches can show hours, minutes and seconds.

Write down the following times :-

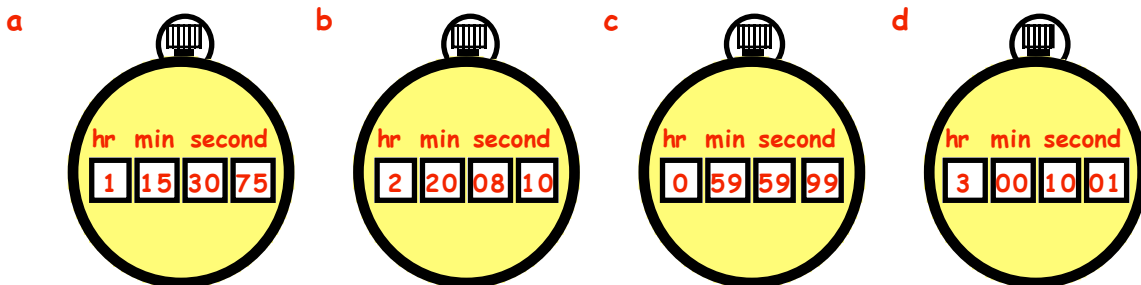

9. Dean won his heat in 2 minutes 29.85 seconds.

Alistair was only $\frac{7}{100}$ of a second behind him.

What was Alistair's time ?



10. Look at the times for 2 runners in a 1500 metres race. Dan and Tom finished well ahead of the other runners.

- a Who won, Dan or Tom ?
- b By how much had the winner beaten the runner-up ?
- c Sid was third and was 5.35 seconds slower than the runner-up.

What was Sid's time for the race ?

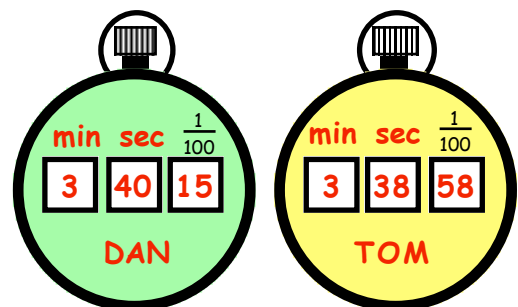

11. Ron's time for the marathon is shown on the stopwatch seen opposite.

Bob's time was 2 hours 50 minutes 30.50 seconds.

- a By how much had Ron beaten Bob ?
- b The very last runner in the race crossed the finishing line 2 hours 10 minutes 15.05 seconds after Ron.

What was his time ?

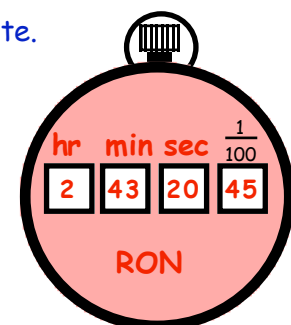

Topic in a Nutshell

1. Convert the following times to **24 hour format** :-

- | | | |
|-----------|-------------------------------|--------------------|
| a 8:45 am | b 2:35 pm | c 5 to midnight |
| d Noon | e $\frac{1}{4}$ past midnight | f 5 to 6 at night. |

2. Write the following in **12 hour format** using **am** and **pm** as appropriate :-

- | | | | |
|--------|--------|--------|--------|
| a 0950 | b 1355 | c 1159 | d 2359 |
|--------|--------|--------|--------|

3. I went into hospital at 0945 for some treatment and did not get away until 1625.

How long was my hospital visit ?



4. Joe, the postman, began his round at 20 past 7 in the morning. His deliveries took him 4 hours and 55 minutes.



At what time did Joe complete his round ?

5. There are two tours of the Duke and Duchess of Beauty's estate. They are listed below.

	Start	Great Hall	Duke's Room	Banquet Hall	Dungeon	Gardens	End
<i>1st Tour</i>	10:30	10:45	11:20	11:55	12:25	1:05	2:00
<i>2nd Tour</i>	12:15	12:30	1:05				

- a How much time was spent in the Banquet Hall ?
- b How long was the whole tour ?
- c Assuming both tours took the same time, at what time would the 2nd tour reach the Dungeon ?



6. New York time is 5 hours **behind** British time. This means that when it is 8:00 pm here, it is only 3:00 pm in New York. My plane left Glasgow Airport at 2250 on Sunday night.

If the flight took 8 hours 30 minutes, at what time (New York time) would I arrive at New York Airport ?

7. Todd's time for a practice circuit at Knockhill Racetrack is shown. Tichmarsh took $\frac{8}{10}$ of a second longer to complete the circuit. What was Tichmarsh's time ?

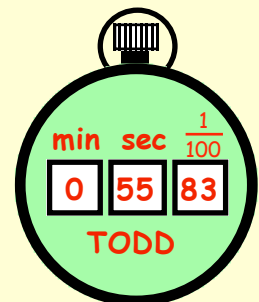

Chapter 4



Mixed Money Problems

Revision

This exercise consists of a mixture of various money problems.

Calculators may be used here, but **all working should be shown**.



Exercise 1

1. Davie looked at his bill from Larry's Sports Shop.

- a Copy the bill and complete it.
- b Davie handed over five £20 notes. How much change did he receive ?

LARRY'S	
Trainers	£39.95
Top	£12.99
Cricket Bat	£29.49
total	£ ?

2.

Bartly's Playpark (daily ticket) (unlimited rides)	
Adult	£6.75
Child	£3.99
Family (2 adults + 2 kids)	£18.75

Mr and Mrs Moffat and their children, Sam and Lucy go to Bartly's for the day.

- a How much would it cost to buy 2 adult and 2 children's tickets ?
- b How much would they **save** by buying the Family Ticket ?

3. Alison, a non-member, goes swimming every Sunday.

- a How much would it cost her to go to the baths for 52 Sundays ?
- Alison decides to become a member.



- b How much would it now cost her to **join and swim** 52 times ?
- c How much would she **save** altogether as a member ?

Bradford Baths	
Single Session :-	
non-member	£2.95
member	£1.75
Membership :-	
1 year	£25.00

4. Jade is a Primary 7 teacher and takes her class of 30 pupils to the Pantomime.

- a How much should it cost her to buy 1 adult and 30 children's tickets ?
- b She notices the "**special offer**". How much will she end up paying if she uses the special offer ?



Aladdin (Standard Price)	
Adult	£7.50
Child	£3.50
Special matinee offer	
Buy 5 child tickets and only pay for 4	

5. The total bill for 6 men going on a skiing weekend including the hotel and hire of skis, came to £497.40.

How much will each man be expected to pay if the bill is shared evenly ?



6.



It costs £4.75 for an adult and £2.95 for a child to go to the Showcase Cinema.

How much will it cost altogether for two families, consisting of 4 adults and 5 children to go watch a film ?

7. I bought a 25 inch TV set at £475.95, a Video Recorder at £139.99 and a DVD player at £157.75 from Morrison's.

- a What should the **total** price be ?
 b How much would I **save** with Morrison's special offer ?



8. Copy and complete the following bills :-

a

	£
3 kg of mince at £2.85/kg	
2 kg stewing steak at £4.35/kg	
$\frac{1}{2}$ kg of fillet steak at £8.50/kg	
total	_____

b

	£
500 g of nails at £0.85/100 g	
800 g screws at £1.36/100g	
20 rubber seals at 45p each	
total	_____

c

	£
3 kg onions at £0.54 / kg	
4 kg leeks at £0.75 / kg	
$\frac{1}{2}$ a cucumber (price for 1 - £1.36)	
total	_____

d

	£
4 memory cards at £29.95 each	
5 packets of paper at £7.99/pack	
Delivery charge of £5.25	
total	_____



9. 2 adult tickets and 5 child tickets for putting comes to exactly the same as that for 4 adults and 2 children.

If an adult ticket is 75p, calculate the cost of a child's ticket.

(Show all your working)



10. Copy the following bills and complete them :-
(VAT is a tax added on by the Government).

a

TV and Video Repairs	
Parts	= £39.75
Labour	= £26.60
Sub Total	= _____
+ VAT	= £11.61
Total Bill	_____

b

BODYSHOP repairers	
New Bumper	= £48.60
Paint	= £17.25
Labour (4hrs at £13.60)	= £
Sub Total	= _____
+ VAT	= £21.04
Total Bill	_____

11. I bought a shirt, a tie and a pair of trousers from the Mensware shop and the bill came to £77.64. I remembered that the trousers were £45.75 and the shirt was £18.99. What must the tie have cost me ?

12. The bill for 5 of us in "Chez Jacques" restaurant, including wine, came to £165.95.

Since it was my birthday, I paid for the wine (£26.75) and the remainder of the bill was split evenly amongst the 5 of us.

What did it cost **me** altogether for my night at the restaurant ?



13. Young's the Bakers, sells muffins.
A box of 8 costs £3.30 and a box of 6 costs £2.55.

Which is the **better deal** ?

(Explain your answer with working).



14. SuperSoap washing powder comes in 2 sizes, as can be seen opposite.

The small one costs £2.65.

The large one costs £3.64.

By calculating the cost of 100 grams of powder for each size of box, say which is the **better deal**.



- 15.



I bought a lovely case of 12 bottles of a Red Chianti wine through the internet for £59.95 + post and package of £4.75.

I saw the same wine at Prestco's at £5.85 per bottle.

How much had I **saved** altogether, by using the internet ?

16. Sara works as a receptionist for Oswald's the Opticians.
Her pay is £5.25 per hour.
Last week she worked for 36 hours.
How much did Sara earn last week ?



17. I bought a pair of vases at a car boot sale for a total of £12.50.
I sold one of them for £27.50 and the second one, because it was chipped, for £6.75.
How much **profit** did I make altogether ?

18.



- Two fish suppers and a hamburger supper cost me £9.80.
If the hamburger was priced at £2.30, what was the price of a fish supper ?

19. Whilst waiting for my delayed flight to take off, I had 4 coffees and 3 rounds of sandwiches. The total bill came to £9.75.
If a round of sandwiches was £1.65, how much must **each** coffee have cost me ?



20. Six friends went for a meal. If the total bill had been shared amongst the 6 of them, each would have had to pay £13.75. Because it was Julie's birthday, the other five decided to treat her and the bill was split 5 ways.
How much did each person really have to pay ?

21. I bought a new widescreen TV set by paying a deposit of £37.50 followed by 9 monthly payments of £18.55.
How much did it cost me **altogether** for my TV set ?

22. How much would it cost (in £'s) to buy :-

- a 20 litres of diesel ?
- b 35 litres of 4 Star ?
- c 31.5 litres of unleaded ?

Price per litre	
4 Star	- 78.2p
Unleaded	- 73.7p
Diesel	- 75.6p

23. I bought **8 pieces** of fruit, a mixture of kiwi fruit and grapefruit. Each kiwi costs 25p and each grapefruit cost 40p.



If the bill came to £2.30, how many of each must I have bought ?
(Hint - make a guess first, check how far out your answer is and re-guess)

24. (Harder). I bought **10 bottles** of wine for a party, white and red. The white were £5.75 each and the red were £4.95 each.
If the bill came to £55.10, find out how many of each I bought.



Foreign Currency

Up until 1st January, 2002, all the countries in Europe had their own type of money (currency).

The euro was introduced and the other currencies were no longer accepted.

Britain still uses the pound (£) and when you go to Europe on holiday you have to change your British pounds into euros.



A **euro** is divided into 100 parts. Each part is called a **cent**.

Exchange Rate :- this is simply the number of euros you get for £1.

Example :- If I change £300 to euros, I receive :-

$$\begin{array}{rcl}
 \text{£} & & \text{€} \\
 1 & \longrightarrow & 1.44 \\
 300 & = & (300 \times 1.44) = \mathbf{432}
 \end{array}$$

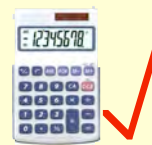

exchange rate
(as of 27th Feb 2008)
£1 = 1.44 euros

Exercise 2

- George flew to Spain and changed £250 to euros. How many euros did he receive?
- Davina changed £500 to euros before going for a week to Venice. How many euros did she get?
- Change the following to euros :-

- | | | | | | |
|---|-------|---|------|---|-------------------------|
| a | £100 | b | £360 | c | £450 |
| d | £1800 | e | £35 | f | £7.55 (to nearest cent) |

- Find the price of the following when changed to euros :-

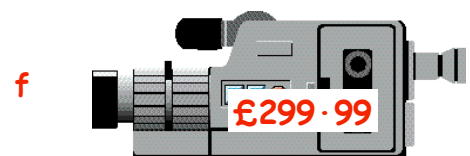

Not every country uses the **euro**.

Shown are some of the **world exchange rates** :-

British Pound (April 2003)		£1 =
American Dollar (\$)		1.59
Australian Dollar		2.59
Chinese Yen		13.17
Danish Krone		10.71
Euro		1.44
Hong Kong Dollar		12.41
Indian Rupee		75.39
Japanese Yen		191.38
Mexican Peso		16.61
New Zealand Dollar		2.88
Norwegian Kroner		11.25
Singapore Dollar		2.84
South African Rand		11.52
Swiss Franc		2.17

5. If I changed £300 to American dollars how many would I receive ?
6. Jamie changed £800 to Yen before flying to Japan.
How many did he receive ?
7. The McPhersons changed £150 to Hong Kong Dollars for a stop-over in Hong Kong.
How many dollars did they receive ?
8. During our two week stay in Mexico, we spent £1200 which we had changed to Pesos.
How much was this in Pesos ?
9. Martin went back-packing around Australia for 3 months. Before he went, he changed £1500 to Australian Dollars.
How many did Martin receive ?
10. I was looking for a digital camera and chose the Olympus C4000Z at £349.
How much would this be in :-



- | | | | |
|---|--------------------|---|----------------|
| a | American Dollars ? | b | Euros ? |
| c | Indian Rupees ? | d | Swiss Francs ? |

11. I saw the same Digital Camera when I was in Australia priced 875 dollars.
Was this cheaper or dearer than I paid for it back home ? (*Show working*).

12. Decide which is the better buy :-

a	Scotland - £399,	Germany - 555 euros.
---	------------------	----------------------



Sony DVP-F41
DVD player
(£399)

- | | | |
|---|--|------------------|
| b | | Britain - £649. |
| | | America - \$999. |



iBook (£649)

- c
 Car price in Britain - £14 500. Same car in Italy - 19 750 euros. |



Only
£14500

Converting back to £'s

In Exercise 2 you learned how to convert British Pounds (£) to Euros (€) by **multiplying**.

If you want to change euros back to pounds => you simply **DIVIDE**.

Example :- I returned from France with 240 euros and changed it back to pounds. How much did I receive ?



€	→	£
1.44	→	1
240 = (240 ÷ 1.44) =		166.666..
		= £166.67

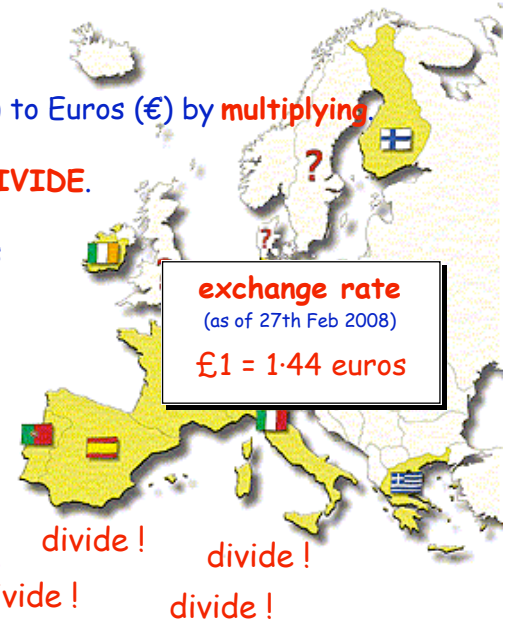

Exercise 3

1. I returned from Pisa in Italy with 432 euros. If I changed it back to £'s, how much would I get ?

2. Natalie came home from Amsterdam with 95 euros. How much would she receive when she took it to the bank and exchanged it for £'s ?

3. Change the following to pounds. (give your answers to the nearest penny).

a 2880 €

b 216 €

c 400 €

d 185 €

e 60 €

f 29.50 €

4.



When she was in Paris, Lynsey bought a new dress in one of the fashion houses for 525 euros. How much was this in pounds ?

5. What are equivalent values of the following items in pounds ?



6. Tania returned from the USA with \$420.
How much would she receive when she converted it back to £'s ?

7. Mr and Mrs Graham and their two children spend the day at a theme park in Zurich, Switzerland.

Entry to the theme park is 69.44 francs per adult and 26.04 francs per child.

What is the total cost of entry for the Graham's in Pounds (£'s) ?

British Pound (April 2003)	
	£1 =
American Dollar (\$)	1.59
Australian Dollar	2.59
Euro	1.44
Hong Kong Dollar	12.41
Indian Rupee	75.39
Japanese Yen	191.38
Mexican Peso	16.61
New Zealand Dollar	2.88
Swiss Franc	2.17

8. a The Scott family are visiting Hong Kong. They hire a car which will travel 14.5 kilometres on one litre of petrol.

How much petrol will they need for a journey of 580 kilometres ?

b Petrol in Hong Kong costs 10.5 dollars per litre.

How much will they have to pay for the petrol for their journey in

(i) dollars (ii) British Pounds ?



9.



Janice is in Japan.

She buys a handbag for 3827.60 Yen, a bracelet for 2966.39 Yen and a scarf for 1531.04 Yen.

She only has £42 worth of traveller's cheques left.

Will this be enough to buy her presents ?

(Explain).

10. Sandeep changed 40 American dollars into Indian currency and received 1896 Rupees.

How much is \$1 worth in Rupees ?

11. Pedro, a Mexican, pays 5481.30 Pesos for his 150 kilometre rail journey through Mexico.

Kylie, an Australian, travels 180 kilometres and pays 979.02 Australian dollars for her rail journey through the Australian outback.

a Calculate the cost per kilometre for each of them.

b By changing the cost per kilometre to pounds find who is getting the better deal.



Topic in a Nutshell

1. James Grady went to a car showroom to buy a new Sports Car which was advertised at £13118.90.

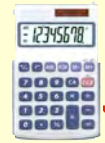

Because he decided to pay the car up, he had to add interest of £2471.50 on to this amount.

If he pays £324.80 each month, how many months will it take to pay off the car ?

2. Mrs Dunbar has a DIY voucher worth £200 to exchange for goods.

She fancies :- a garden shed @ £190.50; a lawnmower @ £177.99
garden shears @ £14.20; a rake @ £7.45 and a power washer at £185.46.

She cannot afford to buy them all.

Make a list of all the possible combinations of goods she could buy with her voucher.



- 3.

El Air
• £437 for 11 days
• Flight + Half-board

Sphinx Tours
• £554.50 for 14 days
• Flight + Half-board

Charles is comparing the cost of going abroad for a break.

He looks at the brochures of two travel companies for holidays to Egypt.

By calculating the cost per day, find which travel company seems to be offering the better deal.



4. Mrs Jackson, the English teacher arranges to take her first year class of 24 pupils to the theatre for the showing of "Hamlet".

- a How much should it cost her to buy 1 adult and 24 children's tickets ?
- b She then notices the special offer available.

Shakespeare's (HAMLET)	
Adult	£6.50
Child	£2.80
Special "Afternoon" Offer	
For every 6 child tickets - only pay for 5	



How much will pay if she takes up the offer ?

5. The bill for a holiday to Austria for a party of six, two of which were children, came to £2020.

As one child was only 8 years old he got free.

The 12 year old got for £212.

The remainder of the cost was split equally among the adults.

What did it cost each adult for the holiday ?



6. a Jaki changed £385 to euros before going on a trip to Paris, France.

How many euros did she get if the exchange rate was 1.44 euros to £1 ?

- b Dave bought a digital camera in Norway for 320.00 euros. He wondered how much this was in pounds ?

At the rate of 1.44 euros to £1, can you tell him the answer ?



7. If I stayed in Magaluf and wanted to buy a holiday apartment there, the price would be 50000 euros.

However, as I live in Scotland, the Property Company dealing with Spanish apartments quoted me a price of £35000.

How much **cheaper** would the apartment cost if I had lived in Spain ?

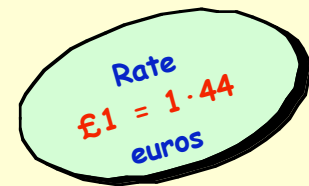

8. Davie earns £26500 a **year** as a joiner.

Harvey is paid £2225.25 per **month** as a plumber.

Nick's **weekly pay** is £507.75 working as a mechanic.

Which of the three is paid the highest ?

(*Show all your working*).



9. At a football match, 10 men bought either a pie or a bridie.

Pies cost 60p and bridies cost 50p.

The total amount spent on pies and bridies was £5.80.

How many of each must have been bought ?

(*show all your workings*).



Chapter 5

Negative Numbers

Negative Numbers

Definition An **INTEGER** is the more mathematical name for what you already know as a **negative** number.

Strictly speaking, an **integer** is simply a **NEGATIVE** or **POSITIVE** whole number (including 0).

Examples :- -3, -29, 7, 31, 0, -1, 10000, -1903, etc. are all **INTEGERS**.
3.5, $\frac{3}{4}$, $2\frac{1}{2}$, -4.1, $1\frac{3}{4}$, -22.7, etc., are **NOT** integers. (Can you see why?)

Exercise 1

1. A **thermometer** is the most obvious place to see positive and negative numbers.

What temperatures are shown here :-

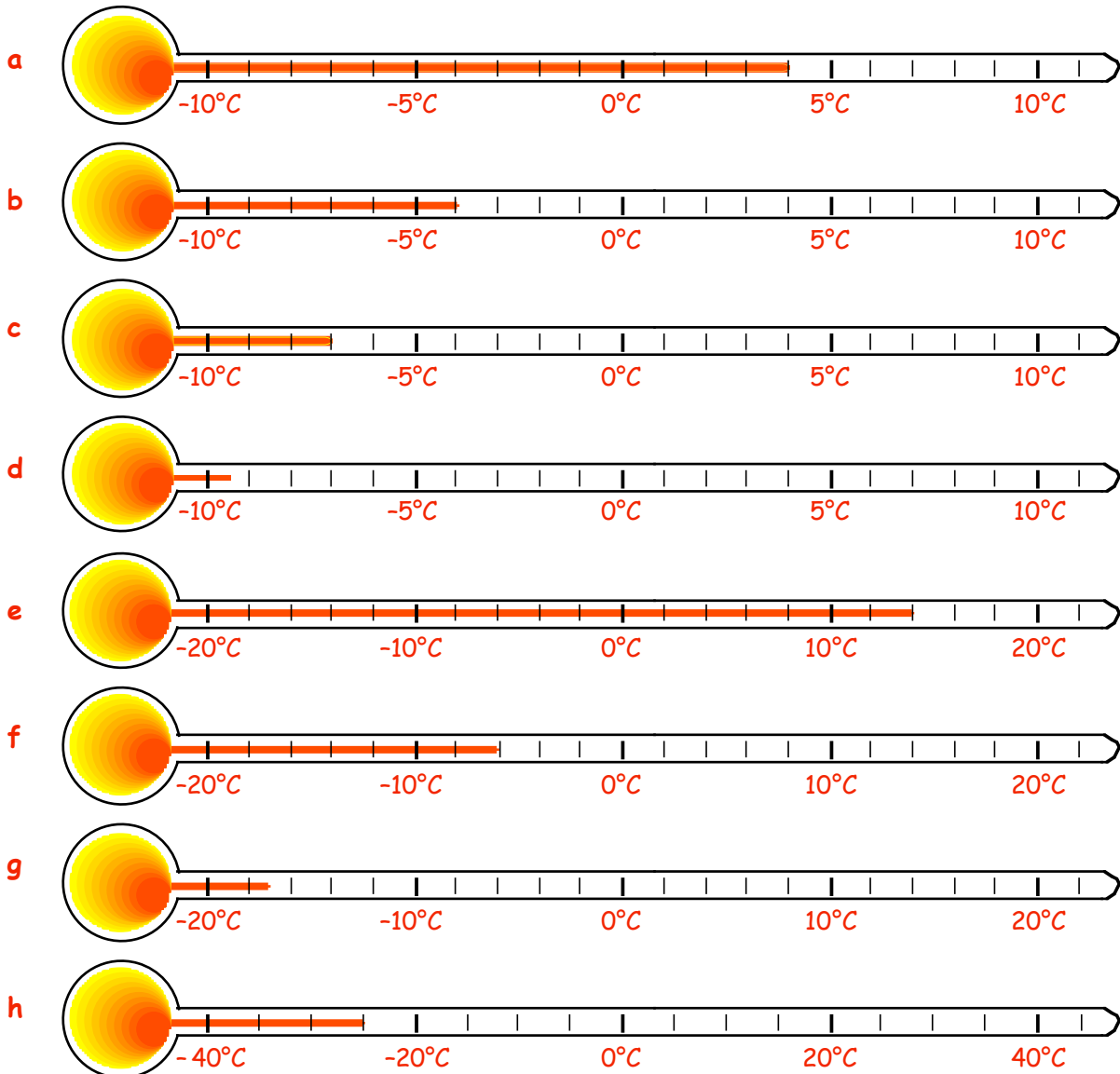

2. You will also come across negative numbers when dealing with money in a bank.

If a man has £65 in his bank account, the computer records this as

+£65.00



- a If he is "overdrawn" by £35, what do you think this will show up as ?
 b What do each of these "bank balances" really mean ?

(i)

<input type="radio"/>		<input type="radio"/>
<input type="radio"/>	15/01/09	<input type="radio"/>
<input type="radio"/>	balance + £18.80	<input type="radio"/>
<input type="radio"/>		<input type="radio"/>

(ii)

<input type="radio"/>		<input type="radio"/>
<input type="radio"/>	31/03/09	<input type="radio"/>
<input type="radio"/>	balance - £27.75	<input type="radio"/>
<input type="radio"/>		<input type="radio"/>

(iii)

<input type="radio"/>		<input type="radio"/>
<input type="radio"/>	06/06/09	<input type="radio"/>
<input type="radio"/>	balance - £125.00	<input type="radio"/>
<input type="radio"/>		<input type="radio"/>

(iv)

<input type="radio"/>		<input type="radio"/>
<input type="radio"/>	01/04/09	<input type="radio"/>
<input type="radio"/>	balance + £0.00	<input type="radio"/>
<input type="radio"/>		<input type="radio"/>

- c Dan had £35 in his bank account and he withdrew £40. What will the computer show his balance to be now ?

- d Diana's bank balance is shown opposite. She paid in £20 to her account. What will her new balance be ?

balance (- £45.00)

- e Richard's bank balance was £0.00. He withdrew £60. What will his new balance be ?

- f Last week Lucy's bank balance stood at (- £35.00). She withdrew a further £15. What will her balance be now ?



- g If Ted's bank balance stood at (- £57), how much must he deposit to "clear his overdraft" ?

- h Angela's balance showed + £23.50. She signed two cheques, one for £12.50 and another for £6.80. What will her new balance now show ?

- i My balance, at the end of last month, was (-£450). The next day, my salary of £1175 was paid in. What was my new bank balance ?

- j Nick's balance last week was (-£24). He signed a cheque for £35 and on the same day his pay of £380 was deposited in the bank. What was his new balance ?



Using Thermometers



A **thermometer** is a useful means of studying negative numbers.

Exercise 2 (No calculator)

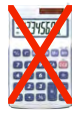

- Use a ruler to copy this thermometer neatly into your jotter.
- Look at your thermometer.

What is the temperature that is :-

- | | | | |
|---|------------------------|---|-----------------------|
| a | 4°C up from 11°C ? | b | 6°C up from 0°C ? |
| c | 15°C up from 7°C ? | d | 9°C down from 15°C ? |
| e | 7°C down from 13°C ? | f | 5°C up from -3°C ? |
| g | 6°C down from -2°C ? | h | 15°C up from -5°C ? |
| i | 8°C down from 3°C ? | j | 22°C down from 0°C ? |
| k | 11°C down from -10°C ? | l | 18°C down from -3°C ? |
| m | 4°C up from -12°C ? | n | 25°C up from -30°C ? |

- Can you see that 8°C is "10°C up from" -2°C ?

Copy and complete these in the same way :-

(say whether it's " .. up from" or " .. down from" each time).

- | | | | |
|---|---------------------------|---|---------------------------|
| a | 10°C is ...°C up from 6°C | b | 3°C is from 10°C |
| c | 0°C is from 11°C | d | 5°C is from -2°C |
| e | -4°C is from 0°C | f | 3°C is from -8°C |
| g | -25°C is from -15°C | h | -6°C is from 6°C |
| i | 30°C is from -30°C | j | -45°C is from -30°C |

- One winter's day in Glasgow, the temperature was -7°C.
In Aberdeen it was 6° colder.

What was the temperature in Aberdeen ?



- When I left my hotel in Iceland, the temperature fell from 15°C to -17°C.

By how much had the temperature changed ?

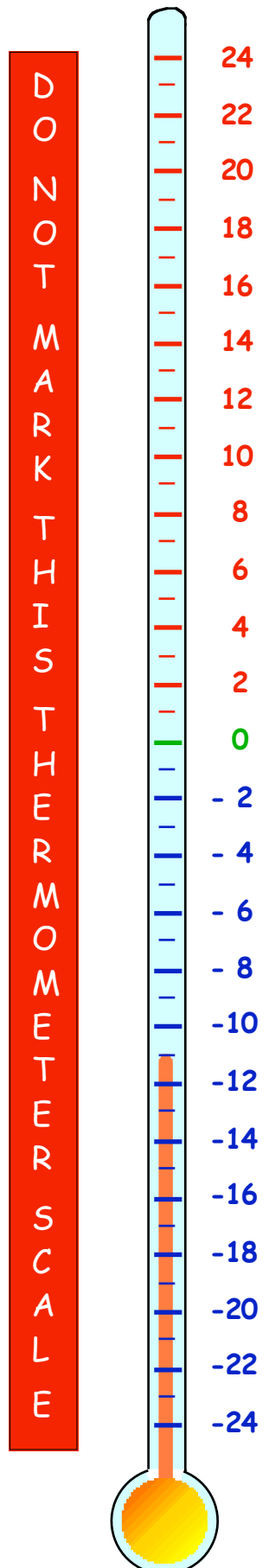

6. Whilst on holiday in Egypt, I noticed the temperature rose from -18°C at night to 32°C at noon in the desert.

By how much had the temperature **risen** ?



7.



When a butcher put a side of beef in his freezer, its temperature fell by a **steady amount** each hour.

It started at 11°C and fell to 7°C in one hour.

What would the temperature be after :-

- a 2 hours ? b 3 hours ?
c 4 hours ? d 7 hours ?

Adding and Subtracting Negatives

When adding and subtracting positive and negative numbers, the best way is to draw or imagine them as temperatures on a thermometer.

Example 1 :- To find $2 + 6$,
imagine the **2** on a thermometer.

To do the "+6" bit, you go **UP** by 6 $\rightarrow 2 + 6 = 8$

Example 2 :- To find $2 + (-6)$,
imagine the **2** on a thermometer.

To do the "+(-6)" bit, you go **DOWN** by 6 $\rightarrow 2 + (-6) = -4$

Example 3 :- To find $7 - 10$,
imagine the **7** on a thermometer.

To do the "-10" bit \rightarrow you go **DOWN** by 10 $\rightarrow 7 - 10 = -3$

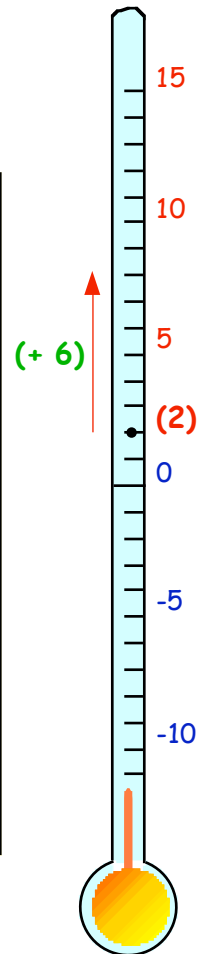

Exercise 3 (No calculator)

Use the **thermometer** which you drew from the last exercise, (or draw a new one), to help you here.



1. Write down each question first, then the answer :-

- | | | | | | | | |
|---|---------------|---|----------------|---|-------------|---|----------------|
| a | $4 + 9$ | b | $2 + 10$ | c | $0 + 5$ | d | $6 + (-4)$ |
| e | $7 + (-3)$ | f | $10 + (-10)$ | g | $6 + (-8)$ | h | $1 + (-7)$ |
| i | $0 + (-11)$ | j | $(-5) + 8$ | k | $(-9) + 9$ | l | $(-2) + 23$ |
| m | $(-12) + 5$ | n | $(-20) + 15$ | o | $4 + (-9)$ | p | $(-3) + (-12)$ |
| q | $(-6) + (-6)$ | r | $(-4) + (-16)$ | s | $(-14) + 5$ | t | $(-16) + 14$ |

2. Again use your thermometer to help here :-

(remember :- $4 - 6$ means "go to 4, then move **down** by 6").

a $7 - 5$

b $15 - 15$

c $7 - 1$

d $4 - 9$

e $3 - 12$

f $7 - 17$

g $0 - 11$

h $(-3) - 5$

i $(-8) - 6$

j $(-15) - 5$

k $(-1) - 19$

l $0 - 23$

m $29 - 49$

n $(-13) - 26$

o $200 - 500$

p $(-69) - 31$

3. A **Mixture** !! The rule is simple.

Picture the **first** number on your thermometer.

If you add a **positive** number move **UP**.

If you add a **negative** number or take away a number move **DOWN**.

a $3 + 8$

b $5 + (-9)$

c $1 - 8$

d $(-2) + 12$

e $-4 + (-6)$

f $13 - 15$

g $(-4) - 8$

h $(-30) + (-20)$

i $-20 + 35$

j $0 - 19$

k $0 + (-19)$

l $(-18) + (-3)$

m $18 + (-3)$

n $(-18) + 3$

o $(-37) + 37$

p $54 - 86$

Coordinates

Revision :- You should know what a Coordinate diagram, (or a **Cartesian** diagram), looks like.

Remember :- x-axis (or horizontal axis).
y-axis (or vertical axis).
The origin (O).
P is 2 (**right**) and 4 (**up**) from the origin.
=> **P(2, 4)**, has x-coordinate 2 and y-coordinate 4.

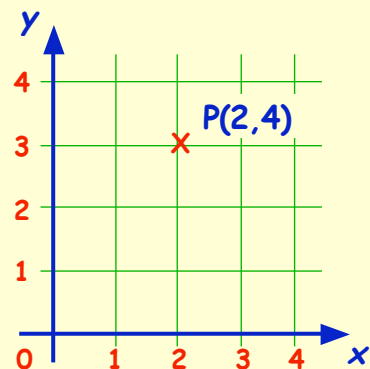

We now extend the set of x and y axes **backwards** and **downwards**.

Look at the numbers on the x- and y- axes.

They now include **NEGATIVE** values.

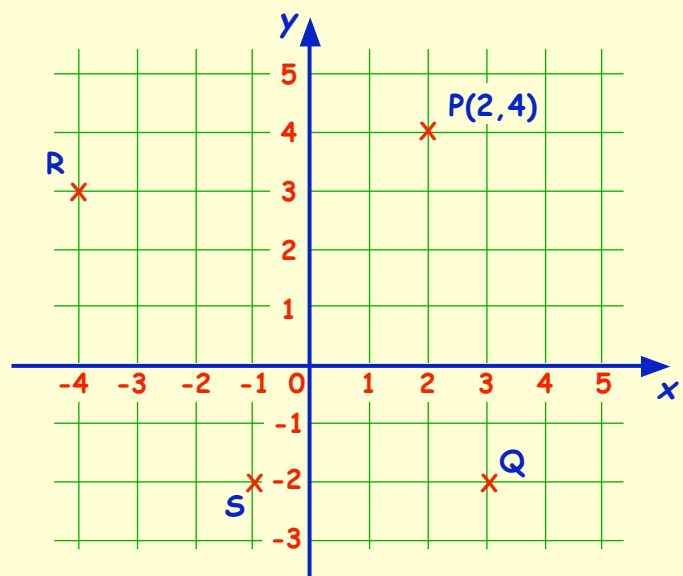

Can you see, from the previous diagram, the following :-

the point Q is 3 (to the right) and 2 (down) from the origin → $Q(3, -2)$

the point R is 4 (to the left) and 3 (up) from the origin → $R(-4, 3)$

the point S is 1 (to the left) and 2 (down) from the origin → $S(-1, -2)$?

Exercise 4

1. Look at this coordinate diagram.

The coordinates of A are

$A(-3, 4)$

Write down the coordinates of the other 8 points.

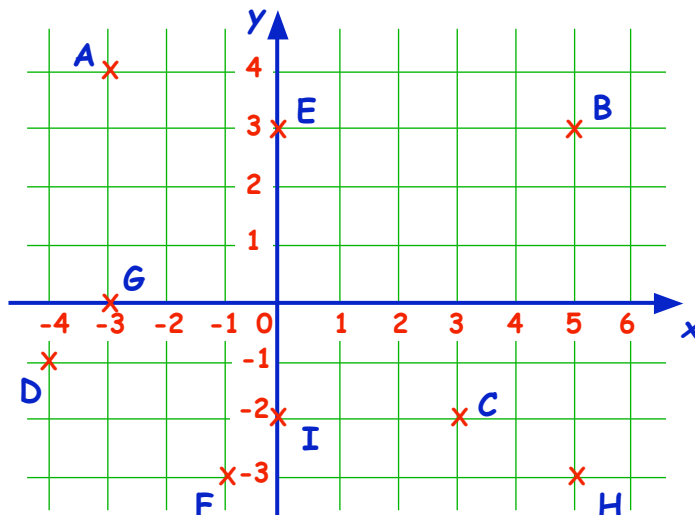

2. Draw a **large** set of axes (-10 to 10 on both scales).

Plot each set of points, join them up and state what shape each is :-

- a $A(3,3)$ $B(5,4)$ $C(7,3)$ $D(5,-2)$. b $E(-7,5)$ $F(-5,8)$ $G(2,8)$ $H(0,5)$.
 c $I(-10,3)$ $J(-8,3)$ $K(-9,-3)$. d $L(1,-5)$ $M(-4,-4)$ $N(-5,1)$ $O(0,0)$.
 e $P(4,-5)$ $Q(6,-7)$ $R(5,-9)$ $S(3,-9)$ $T(2,-7)$.
 f $U(-8,-3)$ $V(-6,-3)$ $W(-5,-5)$ $X(-6,-7)$ $Y(-8,-7)$ $Z(-9,-5)$.

3. a Copy this diagram and plot the three points :-
 $P(-3,2)$, $Q(5,2)$ and $R(5,-3)$.
 b Try to find a 4th point, (call it S), such that PQRS is a **rectangle**. Show S on your diagram, and write down its coordinates.

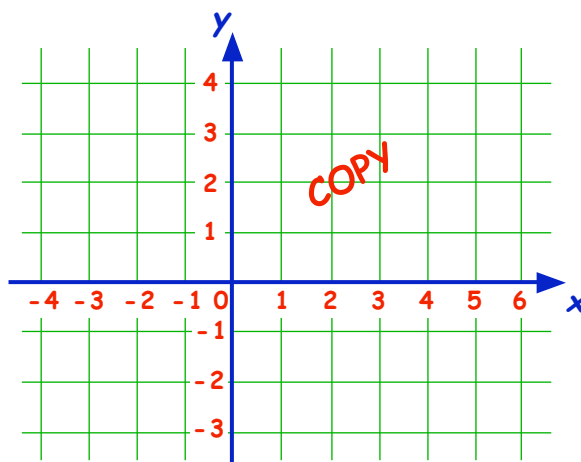

4. Look at triangle ABC.
- a Write down the coordinates of the 3 points, A, B and C.
- b "Flip" $\triangle ABC$ over the x-axis. Write down the new coordinates of the corners of the triangle.
- c Now "flip" your new triangle left across the y-axis and write down the coordinates of the 3rd triangle.

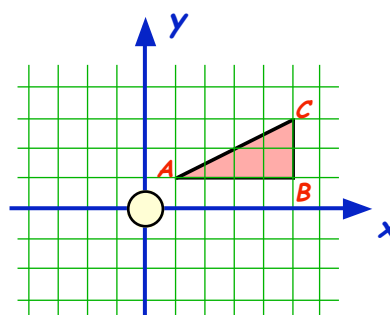

5. a Draw a set of axes, (-6 to 6 on both scales) and plot the four points A(2,1), B(3,5), C(5,5), D(6,1).
- b Join the four points and state what type of shape is formed.
- c "Flip" each of the four points over the x-axis to form a new four-sided shape. (This is called "REFLECTING" the shape).
- d Write down the coordinates of the four corners of this new reflected shape.
6. Draw a new set of axes from -8 to 8 on both scales.
- a Plot the 4 points P(0,1), Q(-1,6), R(-4,7) and S(-5,2) and join them up.
- b Reflect your shape over the y-axis and write down the coordinates of your new shape.
- c Reflect the original shape over the x-axis and write down the coordinates of your new shape.

7. Take a new page in your jotter and in the **middle**, draw a set of axes **lightly** in pencil .

The x-axis is numbered -12 to 12.

The y-axis is numbered -20 to 20.

Use tiny dots to mark each point in the following sets and join them up neatly.

When all the sets, A to K, are drawn, a familiar figure should appear.

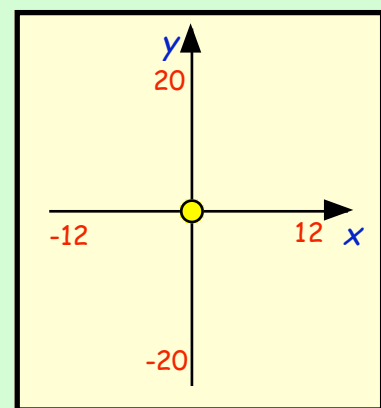

Page

Set A (-5,-16) (-3,-16) (-5,-11) (-3,-7) (9,-1) (10,2) (-3,-7) (-7,-7)
 (-10,-1) (-8,5) (-9,7) (-8,10) (-6,10) (-6,14) (-9,15) (-7,16)
 (-4,16) (-5,18) (5,14) (4,17)

Set B (6,17) (5,14) (9,14) (11,13) (9,12) (7,13) (8,14) (6,12) (4,11)
 (4,12) (2,14) (3,11) (-1,14) (-6,14)

Set C (6,12) (7,0)

Set D (4,9) (6,7) (4,5)

Set E (-5,-16) (-7,-14) (-5,-11) (-7,-7) (-9,-6) (-8,-5)

Set F (-4,-5) (-6,-1) (-4,-1) (1,2) (0,6) (2,1)

Set G (-8,5) (-6,4) (-3,5) (-1,8) (3,3) (2,-3)

Set H (-6,10) (-3,9)

Set I (-2,10) (-1,9) (1,6)

Set J (-4,13) (-5,11) (-4,10) (-3,12) (-4,13)

Set K (-1,13) (-2,11) (-1,10) (0,11) (-1,13). Have Fun !!!!! — **Who is it ?**

Topic in a Nutshell

1. State what temperatures are represented on these thermometers :-



a

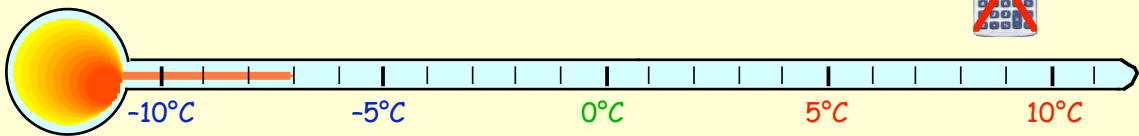

b

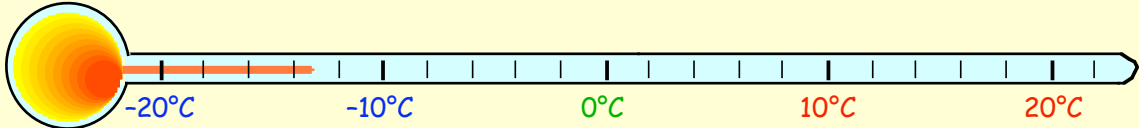

2. Jack's bank balance last month was (-£210).

This month his wage of £600 was paid into his account, but he also paid a phone bill of £145.

What is Jack's new bank balance ?

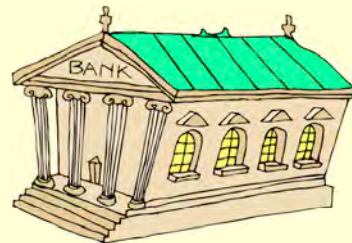

3. Write down what number is :-

a 4 up from -1

b 5 down from 3

c 8 down from -4

d 15 up from -9.

4. Find :-

a $5 + (-3)$

b $7 + (-7)$

c $(-4) + 9$

d $(-9) + 9$

e $(-9) + (-9)$

f $(-5) + (-17)$

g $(-12) + 11$

h $(-101) + 102.$

5. The temperature at midday in Gran Canaria was 24°C .

At midnight it had fallen to -3°C .

By how many degrees had the temperature fallen ?



6. Find :-

a $6 - 8$

b $5 - 12$

c $(-1) - 6$

d $(-4) - 9$

e $0 + (-5)$

f $(-6) - 1$

g $(-48) + 50$

h $23 - 52.$

7. a Copy this coordinate diagram.

b Plot the points :-

$A(-2, 1)$, $B(1, 3)$ and $C(3, 0)$.

c Find a 4th point, (call it D) so that figure ABCD is a **SQUARE**.

Show point D on your diagram and complete the drawing of the square.

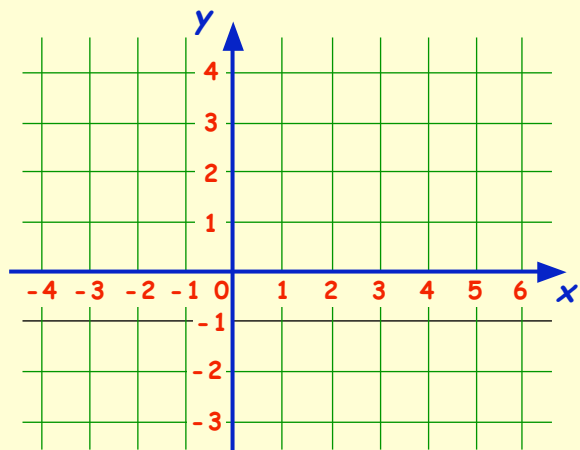

Chapter 6

Fractions & Percentages

Fractions

A fraction consists of 2 parts :-

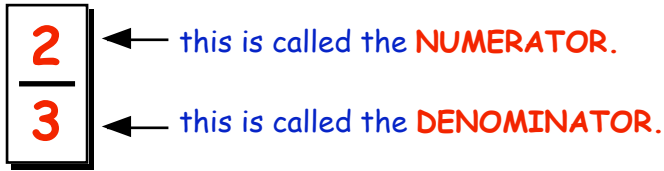

The "denominator" is the name (or type) of fraction you are dealing with (thirds here).

The "numerator" tells you the number or "how many" of the thirds (in this case 2).

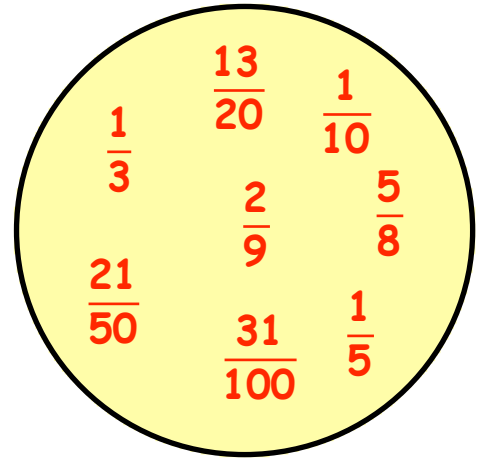

Simplifying Fractions

Exercise 1

1. For each of the following, say what fraction has been coloured :-

a b c d e f g h i j

2. a Use a ruler to draw this rectangle measuring 6 boxes by 2 boxes. Shade in any $\frac{1}{4}$ of it.

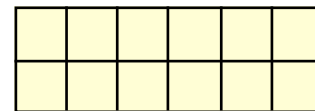

b Draw the same box again.

This time shade or colour in $\frac{1}{6}$ of the shape.

c Draw the same box again. This time shade or colour in $\frac{3}{4}$ of the shape.

d Draw the same box again. This time shade or colour in $\frac{2}{3}$ of the shape.

e Draw the same box again. This time shade or colour in $\frac{7}{12}$ of the shape.

3. Two fractions might look different because they have different **numerators** and different **denominators** but they might still represent the same number :-

Look at the two diagrams representing fractions.

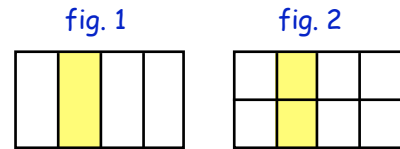

- a What fraction is coloured in figure 1 ?

Can you see that the fraction coloured in figure 2 is $\frac{2}{8}$?

- b What do the two diagrams tell you about the fractions $\frac{2}{8}$ and $\frac{1}{4}$?

4. Copy the following and write down underneath each figure what fraction is shaded.

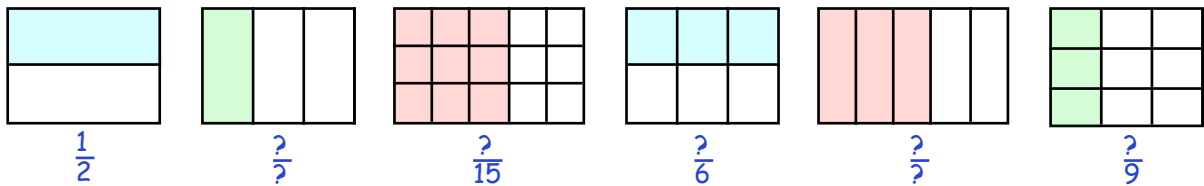

- a From the pictures you can see another fraction equal to $\frac{1}{2}$. ($\frac{1}{2} = \frac{2}{4}$)
 b The second and last diagrams show that $\frac{1}{3}$ is the same as $\frac{2}{6}$.
 c The third and the fifth diagram shows that $\frac{2}{15}$ is the same as $\frac{4}{30}$.

It is possible to find a fraction **equivalent** to $\frac{3}{4}$ by simply "multiplying the numerator and the denominator by any number" :-

$$\Rightarrow \frac{3}{4} \text{ becomes } \frac{3 \times 5}{4 \times 5} = \frac{15}{20} \quad \begin{array}{l} \text{numerator} \times 5 \\ \text{denominator} \times 5 \end{array}$$

5. a Multiply the top and the bottom of $\frac{3}{4}$ by 2 to create a new fraction. What is it ?
 b Multiply the top and the bottom of $\frac{3}{4}$ by 3 to create a new fraction. What is it ?
 c Find at least 4 more fractions equivalent to $\frac{3}{4}$.

6. Multiply the tops and bottoms of each fraction by any simple number to create a new fraction equivalent to the one given :-

a $\frac{1}{3}$ b $\frac{3}{5}$ c $\frac{2}{7}$ d $\frac{7}{8}$ e $\frac{9}{10}$ f $\frac{17}{20}$

We can **SIMPLIFY** fractions (like $\frac{9}{12}$) by "dividing" top and bottom by a number.

$$\Rightarrow \frac{9}{12} \text{ becomes } \frac{9 \div 3}{12 \div 3} = \frac{3}{4} \quad (\text{this is the fraction in its simplest form})$$

7. a Divide the top line and bottom line of each fraction by 3, to simplify each one :-

(i) $\frac{3}{6}$ (ii) $\frac{6}{15}$ (iii) $\frac{21}{24}$ (iv) $\frac{15}{27}$ (v) $\frac{9}{39}$ (vi) $\frac{18}{33}$

cont'd.....

b By dividing the top line and bottom line of each fraction by 4, simplify each one :-

(i) $\frac{8}{12}$ (ii) $\frac{12}{16}$ (iii) $\frac{4}{20}$ (iv) $\frac{20}{24}$ (v) $\frac{28}{32}$ (vi) $\frac{16}{28}$.

c By dividing the top line and bottom line of each fraction by 5, simplify each one :-

(i) $\frac{5}{15}$ (ii) $\frac{10}{25}$ (iii) $\frac{45}{20}$ (iv) $\frac{35}{50}$ (v) $\frac{45}{55}$ (vi) $\frac{100}{105}$

8. For each of the following fractions, divide the numerator and the denominator by a number to simplify the fraction :-

a	$\frac{9}{12} \div 3$	b	$\frac{5}{25}$	c	$\frac{7}{21}$	d	$\frac{8}{24}$	e	$\frac{12}{30}$
f	$\frac{28}{35}$	g	$\frac{9}{15}$	h	$\frac{7}{35}$	i	$\frac{12}{36}$	j	$\frac{70}{100}$
k	$\frac{8}{12}$	l	$\frac{20}{32}$	m	$\frac{50}{75}$	n	$\frac{10}{35}$	o	$\frac{25}{105}$
p	$\frac{12}{16}$	q	$\frac{35}{56}$	r	$\frac{27}{36}$	s	$\frac{33}{55}$	t	$\frac{80}{100}$

Fractions of a Quantity

To find $\frac{1}{4}$ of 12, you simply **divide 12 by 4** $\Rightarrow \frac{1}{4}$ of 12 = (12 \div 4) = 3

To find $\frac{1}{5}$ of 20, you simply **divide 20 by 5** $\Rightarrow \frac{1}{5}$ of 20 = (20 \div 5) = 4

To find $\frac{1}{10}$ of 90, you simply **divide 90 by 10** $\Rightarrow \frac{1}{10}$ of 90 = (90 \div 10) = 9

Exercise 2

1. Find :-

a	$\frac{1}{2}$ of 22	b	$\frac{1}{4}$ of 16	c	$\frac{1}{3}$ of 18
d	$\frac{1}{5}$ of 50	e	$\frac{1}{10}$ of 90	f	$\frac{1}{6}$ of 120
g	$\frac{1}{8}$ of 160	h	$\frac{1}{100}$ of 700	i	$\frac{1}{20}$ of 60
j	$\frac{1}{7}$ of 49	k	$\frac{1}{4}$ of 52	l	$\frac{1}{25}$ of 200



2. Find :-

a	$\frac{1}{3}$ of 156	b	$\frac{1}{4}$ of 368	c	$\frac{1}{5}$ of 315
d	$\frac{1}{6}$ of 1920	e	$\frac{1}{7}$ of 1680	f	$\frac{1}{20}$ of 820
g	$\frac{1}{15}$ of 4500	h	$\frac{1}{11}$ of 1221	i	$\frac{1}{30}$ of 690



To find $\frac{3}{4}$ of a number (like 24), you do it **using 2 steps**.

Step 1 :- Find $\frac{1}{4}$ of 24 first ($\div 4$) $\Rightarrow \frac{1}{4}$ of 24 = $24 \div 4 = 6$

Step 2 :- Now find $\frac{3}{4}$ of 24 by ($\times 3$) $\Rightarrow \frac{3}{4}$ of 24 = $6 \times 3 = 18$

Set the working down as follows :-

$$\frac{3}{4} \text{ of } 24 \Rightarrow (24 \div 4) \Rightarrow 6 \times 3 = 18$$

$$\frac{2}{3} \text{ of } 21 \Rightarrow (21 \div 3) \Rightarrow 7 \times 2 = 14$$

$$\frac{5}{8} \text{ of } 16 \Rightarrow (16 \div 8) \Rightarrow 2 \times 5 = 10$$

Rule :-

To multiply by a fraction like $\frac{5}{6}$
 \Rightarrow "divide by the denominator" (6)
 \Rightarrow then "multiply by the numerator" (5)

3. Without using a calculator, do the following :-

a $\frac{2}{3}$ of 18 = $(18 \div 3) \Rightarrow 6 \times 2 = \dots$

b $\frac{3}{5}$ of 30 = $(30 \div \dots) \Rightarrow \dots \times 3 = \dots$

c $\frac{2}{3}$ of 15

d $\frac{3}{4}$ of 32

e $\frac{2}{5}$ of 25

f $\frac{5}{8}$ of 24

g $\frac{7}{10}$ of 60

h $\frac{5}{9}$ of 27

i $\frac{4}{7}$ of 35

j $\frac{3}{8}$ of 32

k $\frac{9}{10}$ of 60

l $\frac{7}{100}$ of 300

m $\frac{7}{10}$ of 30

n $\frac{7}{8}$ of 160

4. Do the following :-

a $\frac{4}{5}$ of 120 = $(120 \div 5) \Rightarrow 24 \times 4 = \dots$

b $\frac{3}{8}$ of 400 = $(400 \div ?) \Rightarrow ? \times 3 = ??$

c $\frac{3}{4}$ of 120

d $\frac{2}{3}$ of 360

e $\frac{9}{10}$ of 1300

f $\frac{2}{5}$ of 85

g $\frac{7}{9}$ of 360

h $\frac{3}{8}$ of 256

i $\frac{6}{7}$ of 630

j $\frac{5}{6}$ of 174

k $\frac{7}{8}$ of 640

5. a There are 440 adults in St David's congregation. $\frac{5}{8}$ of them are women.

(i) How many women are there ?

(ii) How many men ?

b There are 365 days in a year. It rained on $\frac{4}{5}$ of them.

(i) On how many days did it rain ?

(ii) How many dry days were there ?

c A turtle laid 132 eggs. $\frac{5}{6}$ of them were eaten by birds.

(i) How many eggs were eaten ?

(ii) How many survived ?

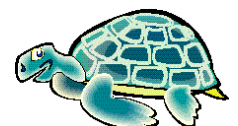

Percentages

When a shape is divided into 100 "bits", each bit is called "1 percent".

$$31\% \text{ means } \frac{31}{100} = 0.31$$

$$7\% \text{ means } \frac{7}{100} = 0.07$$

$$31\% \text{ means } 31 \text{ out of } 100 \text{ or } \frac{31}{100} = 0.31$$

$$7\% \text{ means } 7 \text{ out of } 100 \text{ or } \frac{7}{100} = 0.07$$

note *

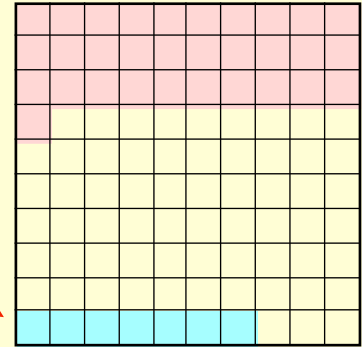

Exercise 3

1. Write each of the following as a fraction **and** as a decimal :-

- a 37% b 45% c 21% d 71% e 83%
f 6% g 4% h 7% i 12.5% j 2.5%

2. Write these percentages as fractions and simplify where possible :-

- a $45\% = \frac{45 \div 5}{100 \div 5} = \frac{9}{20}$ b $90\% = \frac{90 \div 10}{100 \div 10} = \dots$
c 65% d 70% e 25% f 50% g 75%
h 20% i 5% j 24% k 88% l 72%
m 10% n 40% o 35% p 34% q 60%

To change a fraction (for example $\frac{7}{10}$) to a percentage :-

- (i) change to a decimal first (ii) then multiply by 100

$$\frac{7}{10} \text{ means } 7 \div 10 = 0.7, \Rightarrow (0.7 \times 100) = \mathbf{70\%}$$

(calculator)

$$\frac{4}{5} \text{ means } 4 \div 5 = 0.8, \Rightarrow (0.8 \times 100) = \mathbf{80\%}$$

(calculator)

3. You may use a calculator here. Change each fraction to a percentage :-

a $\frac{4}{25} = 4 \div 25 = 0.\dots\dots, \Rightarrow (0.\dots\dots \times 100) =$ %

b $\frac{3}{4} = 3 \div 4 = 0.\dots\dots, \Rightarrow (0.\dots\dots \times 100) =$ %

c $\frac{9}{50}$ d $\frac{3}{5}$ e $\frac{17}{20}$ f $\frac{3}{10}$ g $\frac{13}{25}$ h $\frac{1}{5}$

i $\frac{22}{40}$ j $\frac{47}{50}$ k $\frac{3}{8}$ l $\frac{7}{8}$ m $\frac{36}{40}$ n $\frac{3}{75}$



4. Mandy scored $\frac{32}{40}$ in her music exam.

This can be expressed as a percentage as follows :-



$$\text{Score} = \frac{32}{40} = 32 \div 40 = 0.8, \Rightarrow (0.8 \times 100) = \mathbf{80\%}$$

Change each of these test scores to percentages in the same way :-

- a Sandra scored 24 out of 30 ($= \frac{24}{30} = 24 \div 30, \Rightarrow 0. \dots\dots, \Rightarrow \dots \%$)
- b Tim scored 9 out of 15
- c June scored 36 out of 75
- d Dave scored 32 out of 50
- e Lyn scored 17 out of 20
- f Jenny scored 49 out of 70
- g Linda scored 108 out of 120
- h Jack scored 27 out of 36

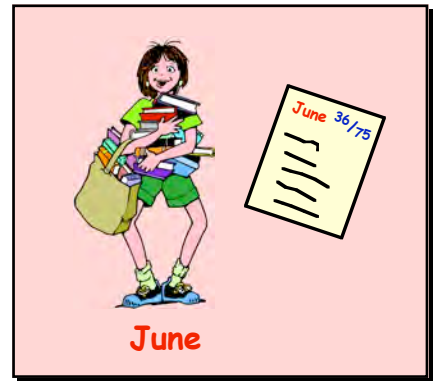

5. The number of girls in the top 4 Maths classes was noted.

$$\begin{array}{ll} 2X_1 - \frac{18}{30} \text{ (18 out of 30)} & 2X_2 - \frac{21}{28} \\ 2X_3 - \frac{16}{25} & 2X_4 - \frac{18}{24} \end{array}$$

- a What percentage of each class was girls ?
- b What percentage of each class must have been boys ?

Finding a Percentage (using a Calculator)

If we wish to find 17% of £450 =>

$$\begin{aligned} 17\% \text{ of } \pounds 450 &= \frac{17}{100} \times 450 \\ &= (17 \div 100) \times 450 = \mathbf{\pounds 76.50} \end{aligned}$$

If we wish to find 4% of £70 =>

$$\begin{aligned} 4\% \text{ of } \pounds 70 &= \frac{4}{100} \times 70 \\ &= (4 \div 100) \times 70 = \mathbf{\pounds 2.80} \end{aligned}$$

note*

Exercise 4

1. Calculate the following :-

- a 17% of £80 = $(17 \div 100) \times 80 = \pounds \dots\dots$
- b 19% of £60 c 35% of £14 d 28% of £650

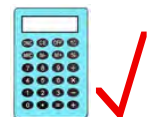

cont'd ...

- | | | | | | |
|----------|---------------|----------|--------------------------------------|----------|------------------------------------|
| e | 47% of £1300 | f | 11% of £90 | g | 59% of £2200 |
| h | 85% of £7.60 | i | 7% of £11 | j | 2% of £350 |
| k | 44% of £12.50 | l | 85% of 40p | m | 64% of £7.50 |
| n | 9% of £24 | o | $12\frac{1}{2}\%$ of £124
(12.5)% | p | $3\frac{1}{2}\%$ of £250
(3.5)% |

2. **a** Of the 360 office workers in a call centre, 65% are women.

(i) How many women are there ?

(ii) How many men are there ?

b An assistant chef has to peel 40 kg of potatoes for an evening meal. The peelings make up 12% of the potatoes' weight.

What is the weight of the peelings ?



c The rental on a flat is £360 per month. Ted and Lucy get a special deal and only have to pay 80% of this.

How much did they pay per month ?

d During a storm, I lost 8% of my roof tiles. If there were 850 tiles on the roof before the storm, how many were lost ?



e In 1990 the silver birch tree in my garden was 2.5 metres tall.

By 1995 it had grown by 40%.

(i) By much had it grown ?

(ii) What was the new height of the birch tree ?

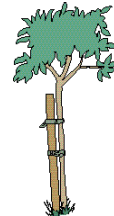

f A university noticed that 16% of the new students dropped out by the end of their first year.

If there were 1350 new students, how many dropped out ?

g Of a group of 800 people surveyed :-

30% read the Sun, 45% read the Record, 15% read the Herald and the rest read the Express.

How many of the 800 people read the :-

(i) Sun ?

(ii) Record ?

(iii) Herald ?

(iv) Express ?



h



The diameter of Mars is only 55% of of the Earth's diameter.

If the diameter of Earth is 13000 km, what is the diameter of Mars ?

Finding (Simple) Percentages

On page 72, you discovered how to find 17% of £450 using a calculator.

$$17\% \text{ of } \pounds 450 = \frac{17}{100} \times \pounds 450 = (17 \div 100) \times \pounds 450 = 76.5 = \pounds 76.50$$

There are many percentages which you will come across often, and these can be represented by simple fractions.

for example, $50\% = \frac{50 \div 10}{100 \div 10} = \frac{5 \div 5}{10 \div 5} = \frac{1}{2} \Rightarrow 50\% = \frac{1}{2}$

Exercise 5

1. Find out which percentages match up with which fractions :-

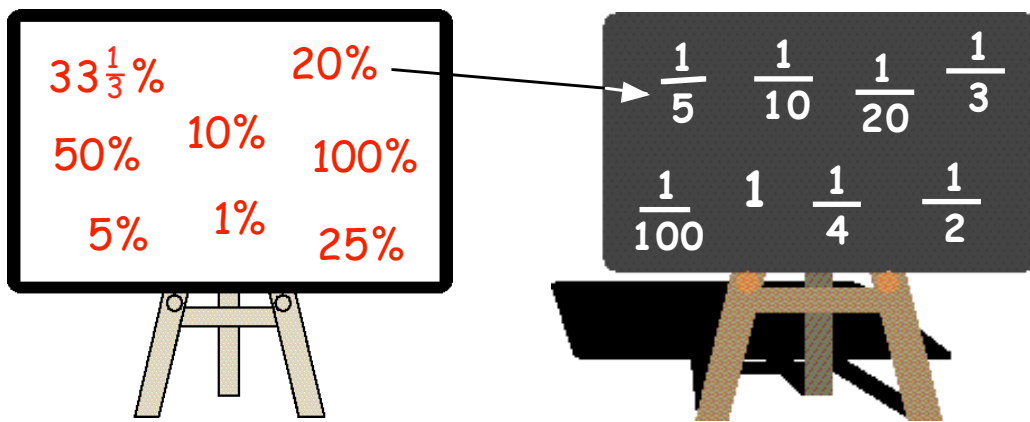

2. Make a copy of this table and complete it.

percentage	100%	50%	$33\frac{1}{3}\%$	25%	20%	10%	5%	1%
fraction	?	$\frac{1}{2}$?	?	?	?	?	?

You can now do (simple) percentage calculations without a calculator.

Example :-

$$50\% \text{ of } \pounds 120 \text{ means } \frac{1}{2} \text{ of } \pounds 120 (= 120 \div 2) = \pounds 60$$

$$20\% \text{ of } \pounds 35 \text{ means } \frac{1}{5} \text{ of } \pounds 35 (= 35 \div 5) = \pounds 7$$



3. Do the following **MENTALLY** :-

a 50% of £60 b 50% of 220 c 50% of 6400

4. Remember :- 25% means $\frac{1}{4}$. Find, without a calculator :-

a 25% of £36 (= $\frac{1}{4}$ of 36 = $36 \div 4 = \pounds \dots$)

b 25% of £80 c 25% of £1.60 d 25% of £4800

5. Find the following without a calculator :- (remember $33\frac{1}{3}\%$ means $\frac{1}{3}$)
- a $33\frac{1}{3}\%$ of £24 b $33\frac{1}{3}\%$ of £90 c $33\frac{1}{3}\%$ of £1500
6. Find the following without a calculator :- (use the equivalent fraction instead)
- a 50% of £180 b 20% of £65 c 10% of £35
d $33\frac{1}{3}\%$ of £600 e 1% of £600 f 20% of £2.50
g 100% of £43 h 25% of £3.60 i 5% of £120
j 10% of £2600 k $33\frac{1}{3}\%$ of £180 l 25% of £120 000
7. 20% of the pupils in a school of 350 have blonde hair.
How many blondes are there in the school ?
8. My bank charges me 1% to change my holiday money into dollars. 
If I changed £1200 into dollars, how much was I charged ?
9. A bottle of beer states "**contains 5% alcohol**".
If the bottle holds 500 ml of liquid, how much alcohol does it contain ?
10. My "cotton" socks actually are made of $33\frac{1}{3}\%$ nylon. 
If my socks weigh 360 grams, how much nylon do they contain ?

You already know

$50\% = \frac{1}{2}$

Since $10\% = \frac{1}{10}$
→ $30\% = \frac{3}{10}$
→ $70\% = \frac{7}{10}$
→ $90\% = \frac{9}{10}$

Since
→ $20\% = \frac{1}{5}$
→ $40\% = \frac{2}{5}$
→ $60\% = \frac{3}{5}$
→ $80\% = \frac{4}{5}$

Since
→ $25\% = \frac{1}{4}$
→ $75\% = \frac{3}{4}$

Since
→ $33\frac{1}{3}\% = \frac{1}{3}$
→ $66\frac{2}{3}\% = \frac{2}{3}$

Exercise 6

1. Make a copy of the list shown below and **LEARN** it.

percentage	50%	25%	75%	$33\frac{1}{3}\%$	$66\frac{2}{3}\%$	20%	40%	60%	80%	10%	30%	70%	90%
fraction	$\frac{1}{2}$	$\frac{1}{4}$	$\frac{3}{4}$	$\frac{1}{3}$	$\frac{2}{3}$	$\frac{1}{5}$	$\frac{2}{5}$	$\frac{3}{5}$	$\frac{4}{5}$	$\frac{1}{10}$	$\frac{3}{10}$	$\frac{7}{10}$	$\frac{9}{10}$

This means if you want to find 75% of £80, you do it as follows :-

$$75\% \text{ of } \pounds 80 = \frac{3}{4} \text{ of } \pounds 80 = (80 \div 4) \times 3 = \pounds 60$$

2. Do the following in the same way :-

- a 60% of £40 = $\frac{3}{5}$ of £40 = $(40 \div 5) = 8 \times 3 = \pounds 24$
- b 30% of £60 = $\frac{3}{10}$ of £60 = $(? \div 10) = ? \times 3 = \pounds \dots$
- c 75% of £24 = $\frac{3}{4}$ of £... = $(? \div ?) = ? \times 3 = \pounds \dots$
- d $66\frac{2}{3}\%$ of £18 = ? of £18 = $(? \div ?) = ? \times ? = \pounds \dots$



3. Do the following **MENTALLY** by using the fractions instead of the percentages :-

- a (i) 10% of £120 (ii) 70% of £120
- b (i) 20% of £45 (ii) 80% of £45
- c (i) 25% of £2.40 (ii) 75% of £2.40
- d (i) $33\frac{1}{3}\%$ of £150 (ii) $66\frac{2}{3}\%$ of £150
- e (i) 10% of £140 (ii) 30% of £140
- f (i) 20% of £350 (ii) 60% of £350
- g (i) $33\frac{1}{3}\%$ of £9.30 (ii) $66\frac{2}{3}\%$ of £9.30
- h (i) 25% of £36 (ii) 75% of £36
- i (i) 10% of £180 (ii) 5% of £180 (half of 10%)
- j (i) 1% of £700 (ii) 9% of £700



4. No calculator here. Use the above "two step" approach to find the following :-

- a 60% of £45 (think of 20% = $\frac{1}{5}$ of £45 first, then)
- b 75% of £480 c 80% of £3500 d 30% of £120
- e $66\frac{2}{3}\%$ of £4.50 f 90% of £30 g 70% of £1100
- h 3% of £800 i 40% of £75 j 5% of £320

5. **Harder !!** (no calculator)

Try to think of a (mental) way of finding 15% of £600.

Topic in a Nutshell

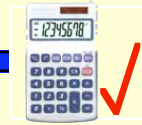

1. For each shape, say what fraction has been coloured :-

a

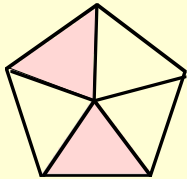

b

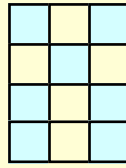

c

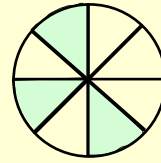

2. Write down **two** fractions equivalent to :-

a $\frac{1}{2}$

b $\frac{2}{5}$

c $\frac{3}{10}$

3. Write each of these fractions in their **simplest** form :-

a $\frac{8}{16}$

b $\frac{15}{20}$

c $\frac{9}{24}$

4. Find :-

a $\frac{1}{2}$ of 30

b $\frac{1}{4}$ of 36

c $\frac{1}{3}$ of 24

d $\frac{1}{5}$ of 45

e $\frac{1}{10}$ of 120

f $\frac{1}{20}$ of 200

g $\frac{2}{9}$ of 18

h $\frac{3}{4}$ of 36

i $\frac{7}{8}$ of 32

j $\frac{5}{6}$ of 1278

k $\frac{3}{7}$ of 406

l $\frac{3}{8}$ of 872

5. Of the 60000 fans who attended the UEFA cup final in Seville only $\frac{3}{8}$ were supporting Oporto.

a How many Oporto supporters were there ?

b How many supporters did their opponents, Celtic have ?



6. Write these percentages as fractions in their **simplest** form :-

a 10%

b 80%

c 35%

d 12%

e 44%

f 7.5%

7. Change these fractions into **percentages** :-

a $\frac{3}{50}$

b $\frac{4}{5}$

c $\frac{7}{10}$

d $\frac{5}{8}$

8. From a £20 note, I spent £8 of it going to the cinema.
What **percentage** was this ?

9. Victor scored 34 out of 40 in his History exam and got 24 out of 30 for Geography.

Convert both marks into **percentages** and state in which exam he did better.



10. Calculate :-

- | | | | | | |
|---|---------------------------|---|---------------|---|--------------|
| a | 24% of £180 | b | 5% of £1200 | c | 85% of 60p |
| d | $33\frac{1}{3}\%$ of £300 | e | 17.5% of £140 | f | 20% of £4.50 |

11. 48% of the population of Prestwick are senior citizens.

If Prestwick has 12 500 inhabitants, how many are senior citizens ?



12. Do the following, **without** using a calculator :-

- | | | | | | |
|---|------------------------|---|--------------------------|---|------------|
| a | $33\frac{1}{3}$ of £15 | b | 10% of 40p | c | 25% of £30 |
| d | 5% of 60p | e | $66\frac{2}{3}\%$ of £72 | f | 90% of £80 |

13. a I spent $\frac{1}{3}$ of my money on an ice-cream cone and still had £1.20 left.
How much must I have started with ?

- b My petrol tank was exactly $\frac{1}{4}$ full.
It took 24 litres of petrol to fill the tank.
How many litres of petrol does my tank hold **altogether** ?

- c Billy drove $\frac{2}{5}$ of the way from Aylsbury to Brackie.
He still had 12 miles to go.
How far is it **altogether** from Aylsbury to Brackie ?



Revision - Line Symmetry

Remember :- A line of symmetry occurs in a shape if, when the shape is folded over the line, "the two pieces, either side of the line, are exactly the same".



These shapes have lines of symmetry :-

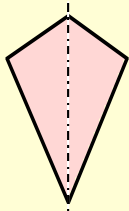

1 line of symmetry

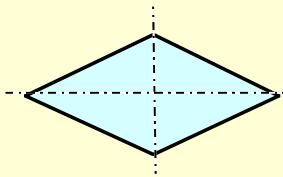

2 lines of symmetry

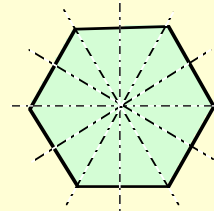

6 lines of symmetry

Exercise 1 (You will need a ruler and tracing paper)

- Make a neat tracing of each of the following shapes. Use a coloured pencil to show all the lines of symmetry. Write down beside each shape how many lines of symmetry it has.

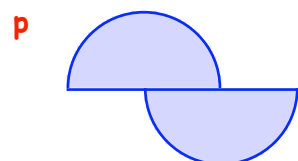
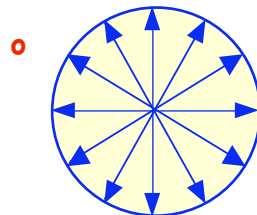
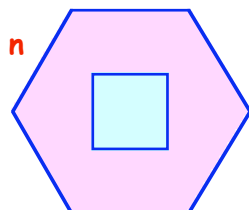
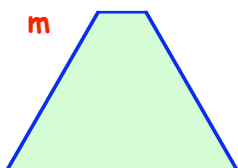
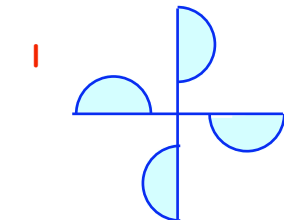
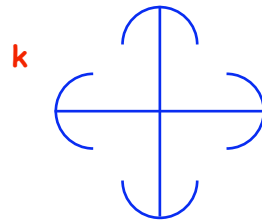
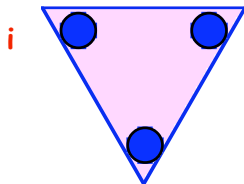
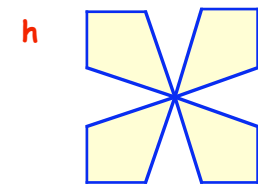
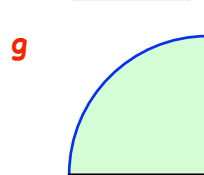
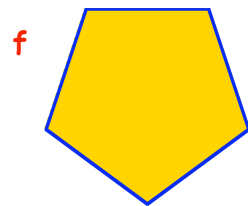
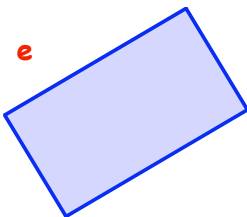
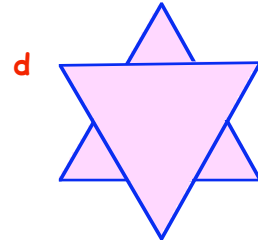
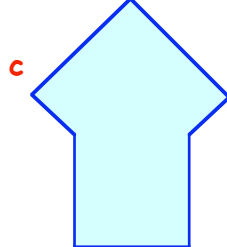
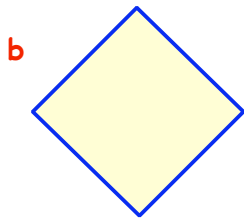
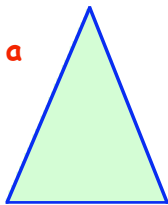

2. Copy each of the following shapes neatly and complete each one such that the red line is a line of symmetry each time.

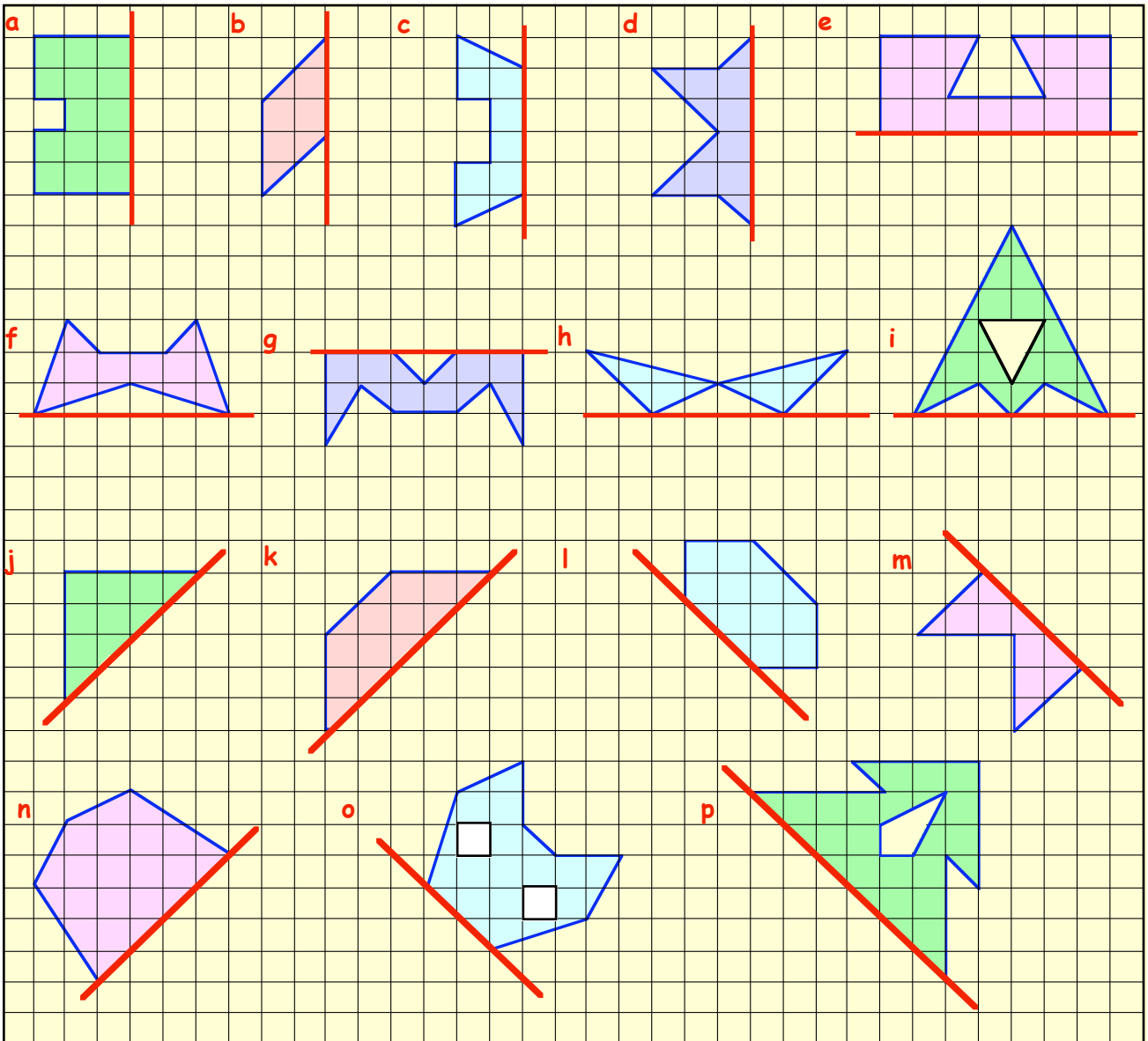

3. This time, each shape has to have 2 lines of symmetry (shown as red lines). Carefully copy and complete each shape.

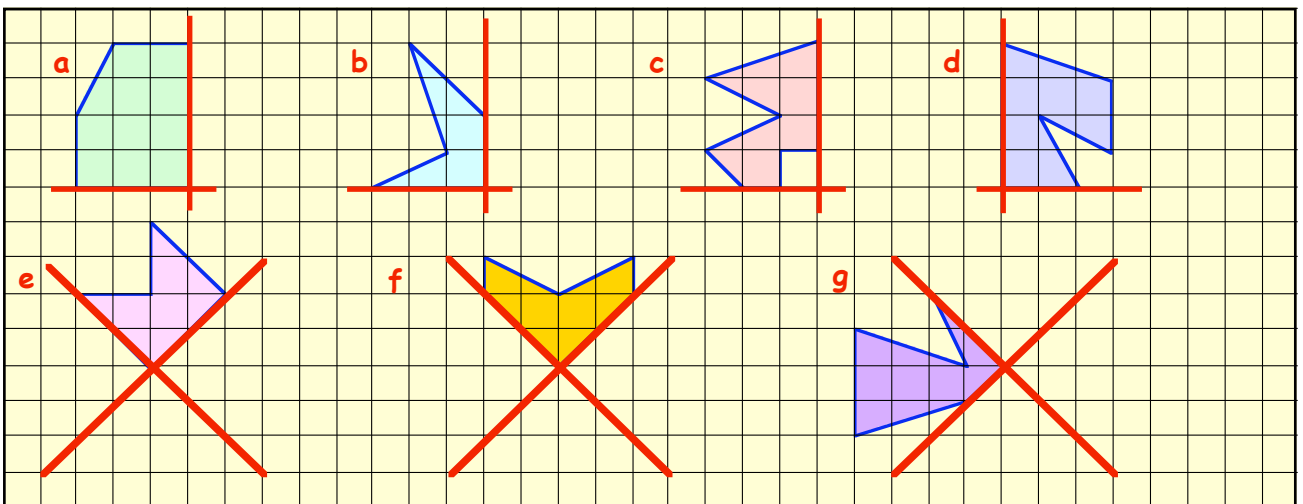

4. Jodie makes up a new computer font. She draws each letter and number using a square 2 by 2 grid.

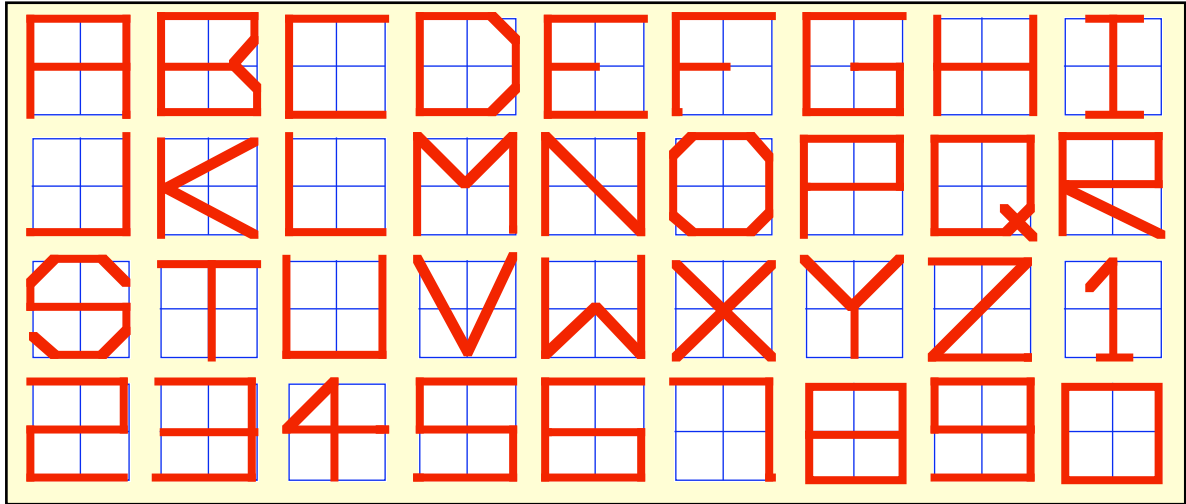

- From Jodie's set of letters and numbers, write down all of those that have exactly 1 line of symmetry.
 - Which of them have 2 lines of symmetry?
 - Which letters and numbers from the font set have **NO** lines of symmetry?
 - The letter O, in Jodie's fonts, has **four** lines of symmetry. Make a new design for the letter O in such a way that it has **eight** lines of symmetry.
5. Copy each of the following onto squared paper and complete each shape such that the **red** line is a line of symmetry.

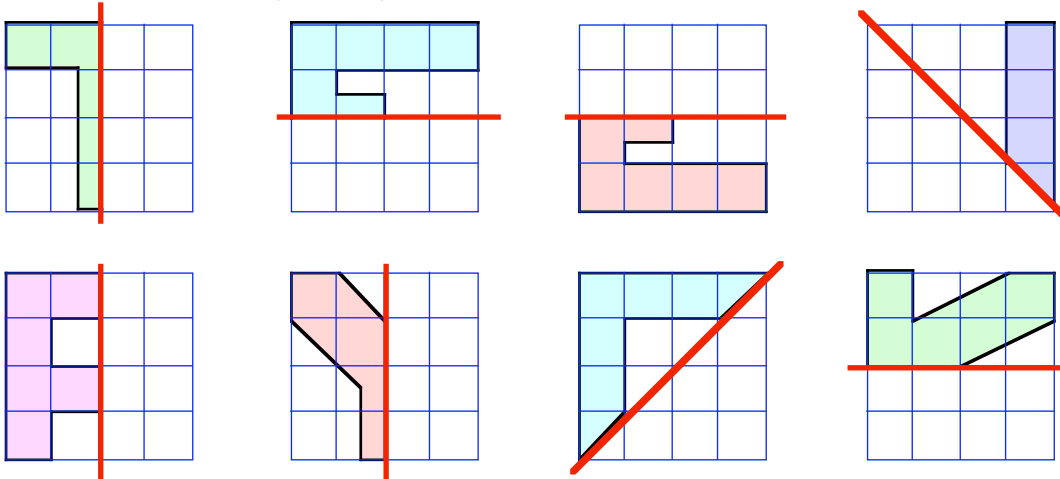

6. Create a new font set of the 26 letters and 10 numbers on a 3 by 3 grid.

Make each letter or number have as many lines of symmetry as possible.

Say how many lines of symmetry each has.

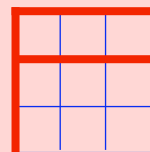

Turn (or Rotational) Symmetry

Look at the shape opposite.

Can you see that it has **NO** lines of symmetry?

Can you also see that if you "spin" the shape by 180° (half a turn) around the **red** dot, it will fit back onto its own outline?

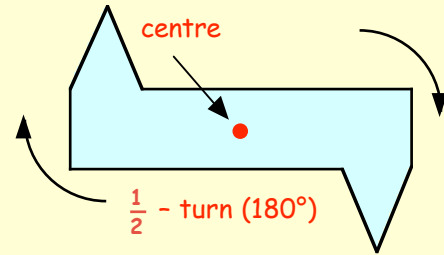

we say :- It has " $\frac{1}{2}$ - turn symmetry". (or Rotational Symmetry "of order 2").

Exercise 2

1. Which of the following shapes have **half-turn** symmetry?

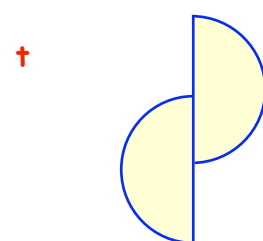
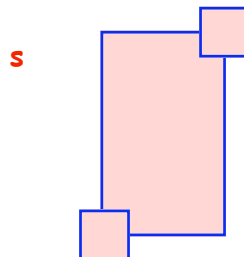
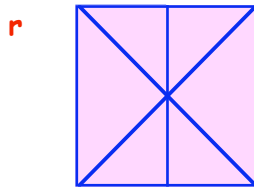
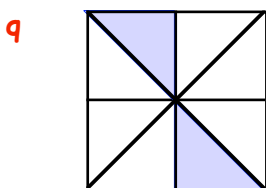
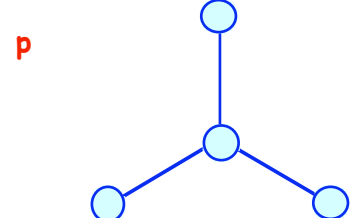
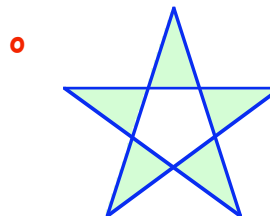
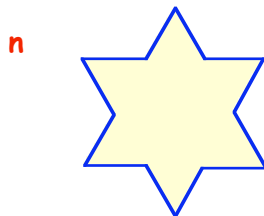
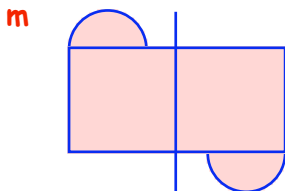
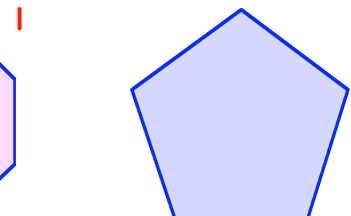
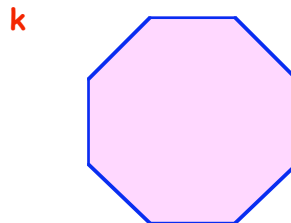
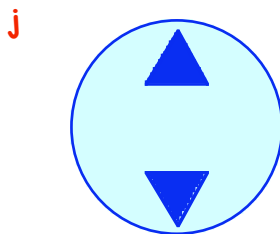
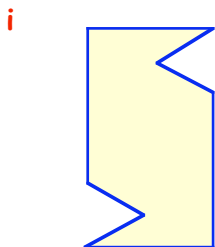
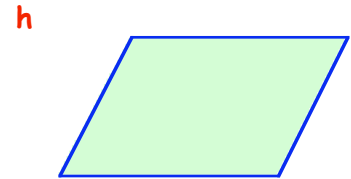
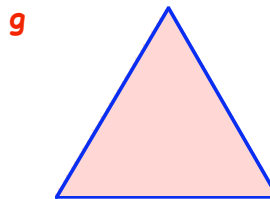
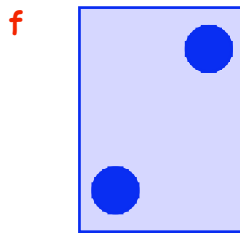
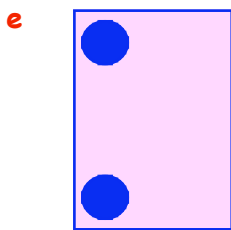
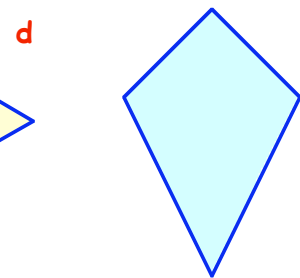
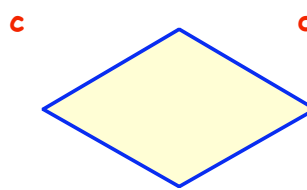
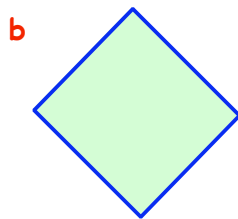
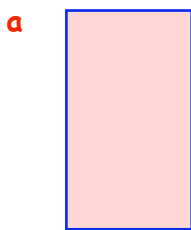

2. Remember Jodie's Font Set ?

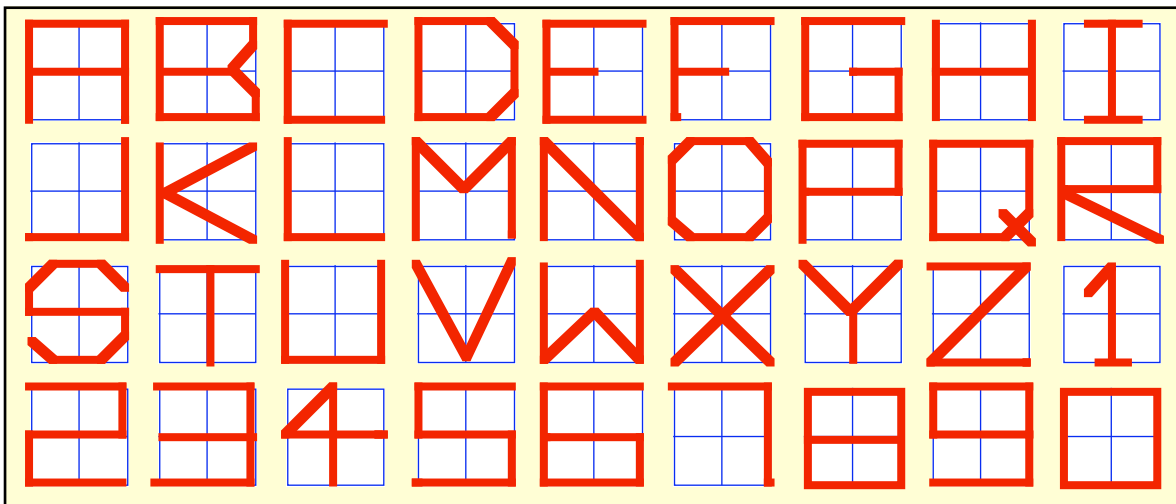

- a Make a list of those letters and numbers that have $\frac{1}{2}$ - turn symmetry.
- b From those with $\frac{1}{2}$ - turn symmetry, which ones have at least 1 line of symmetry ?

Turn Symmetry (continued).

You should have seen in question 1 g that the equilateral triangle does not have $\frac{1}{2}$ -turn symmetry (rotating it by a half turn (180°) left it "upside-down").

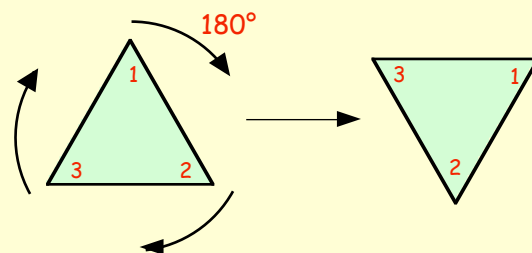

However, if you rotate it by 120° (a **third** of a turn) it will fit back onto itself.

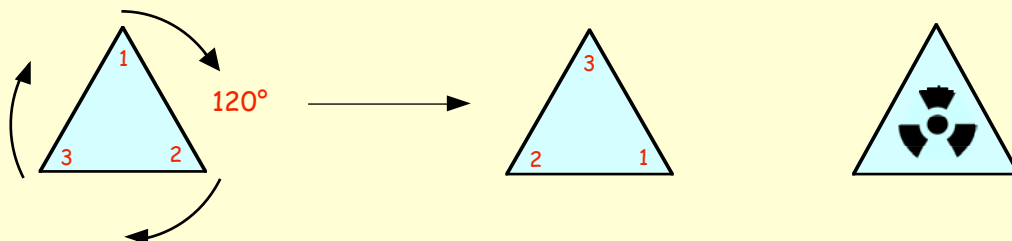

we say :- **It has " $\frac{1}{3}$ - turn symmetry"**. (or Rotational Symmetry "**of order 3**").

3. Look at this shape

- a Does it have any lines of symmetry ?

It obviously has "half-turn symmetry".

- b As well as 180° , what other size of angle could the shape be rotated by around its centre so that it fitted back onto itself ?

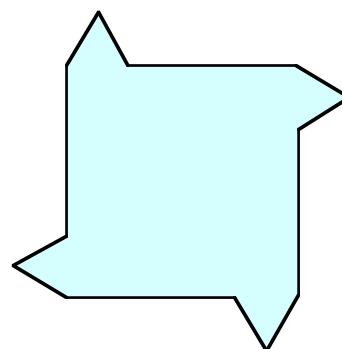

- c Copy and complete :-

"The shape has - turn symmetry, or rotational symmetry of order ...".

insert a fraction

4. Each of the following shapes has "turn symmetry".
 For each shape, say what kind of "turn" symmetry it has. ($\frac{1}{2}$, $\frac{1}{3}$, $\frac{1}{4}$, $\frac{1}{5}$, $\frac{1}{6}$, $\frac{1}{8}$, etc),
 and state the "order" of rotational symmetry.

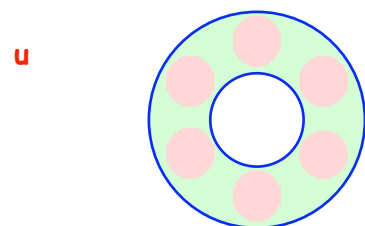
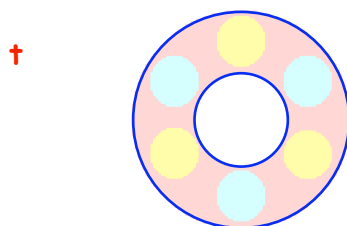
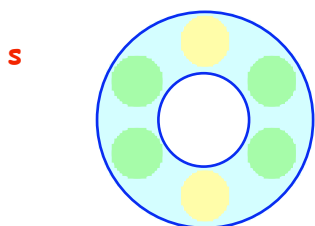
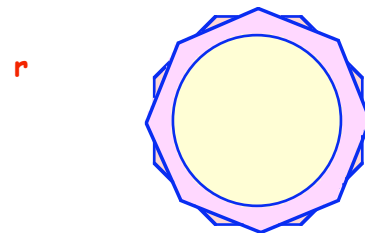
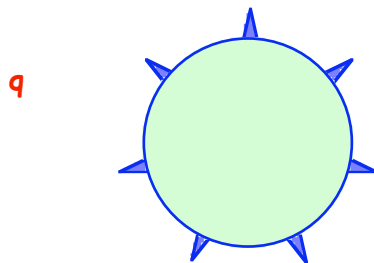
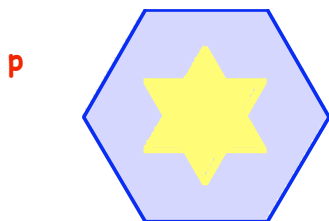
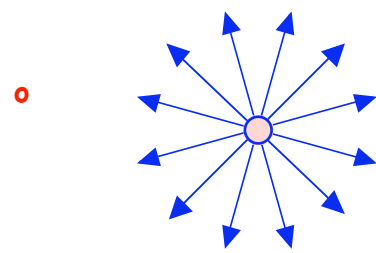
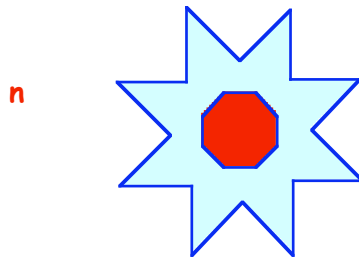
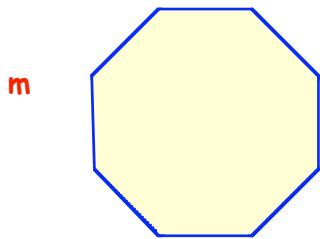
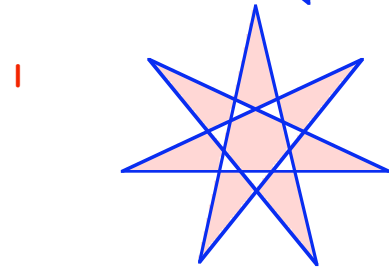
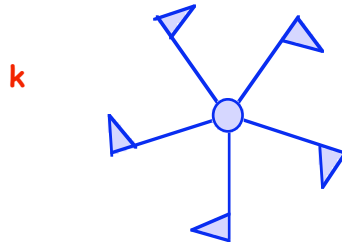
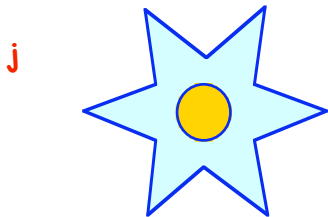
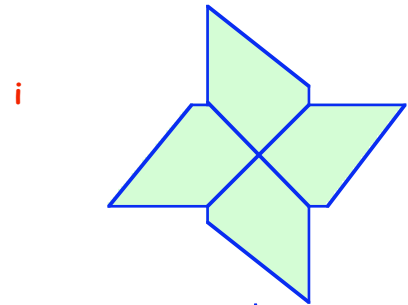
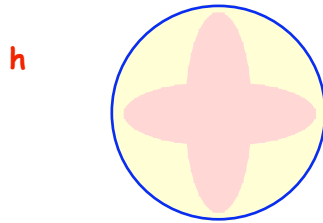
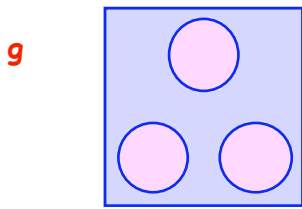
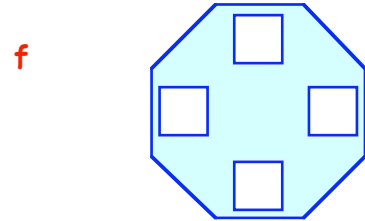
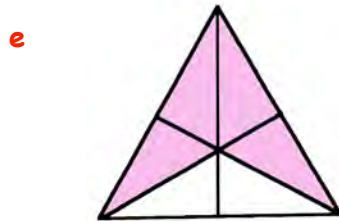
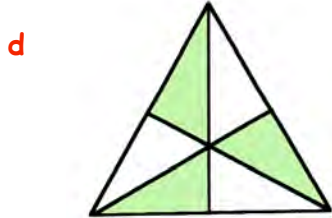
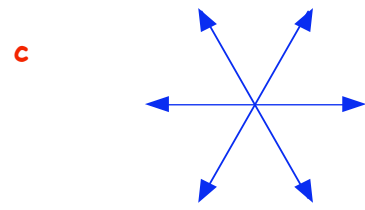
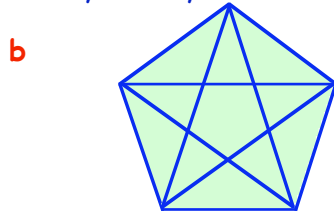
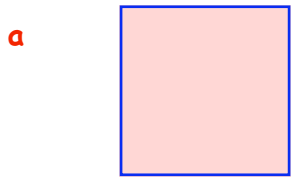

Creating a Shape with $\frac{1}{2}$ -turn Symmetry

If we take a given shape and spin it 180° around a fixed point, then this new shape, along with the original will form a figure which will have $\frac{1}{2}$ -turn symmetry.

In this diagram, the dot has to be the centre of symmetry.

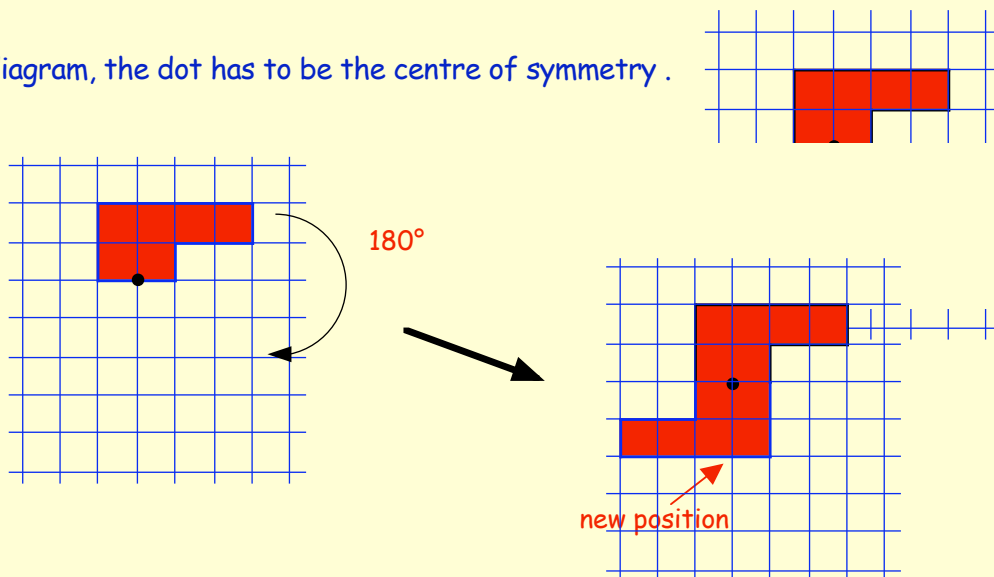

Exercise 3 (You will need $\frac{1}{2}$ cm squared paper)

1. a Make a copy of this rectangle.
- b Now rotate it by a $\frac{1}{2}$ turn around the red dot.

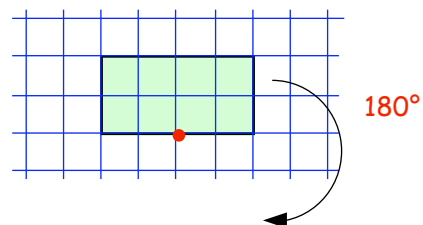

2. Copy this figure and rotate it by half a turn around the red dot.

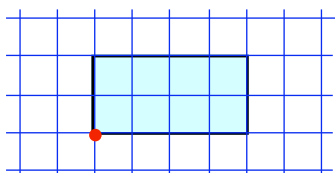

3. Do the same here with this triangular shape.

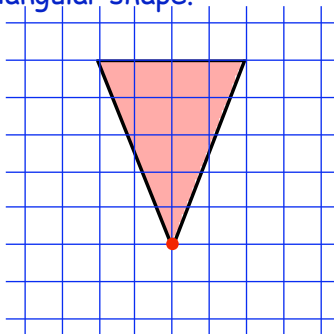

4. Make a copy of each of the following shapes neatly and carefully.
Create a shape which has got half turn symmetry by rotating each shape by 180° around the given dot :-

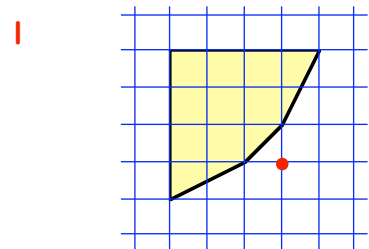
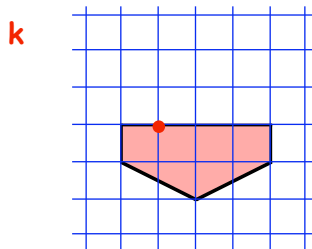
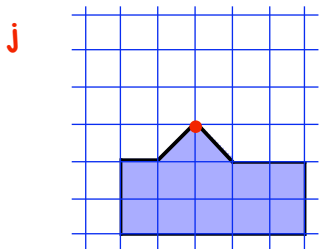
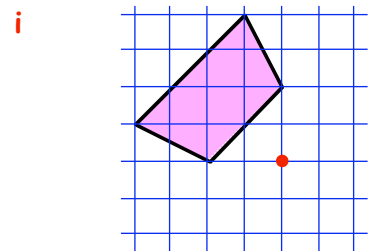
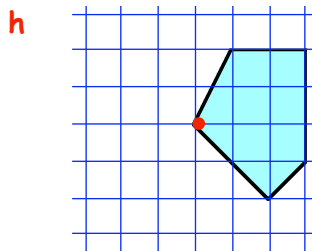
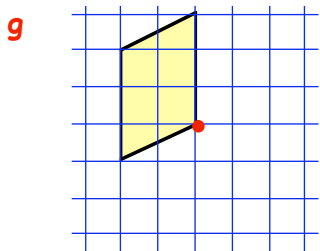
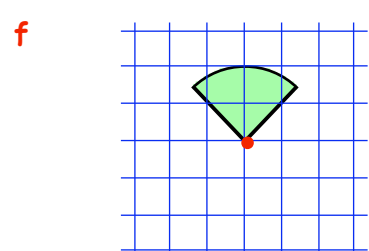
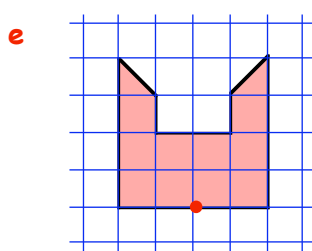
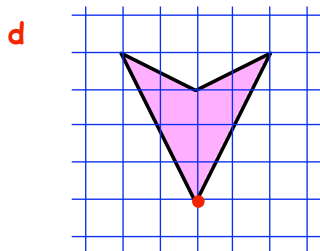
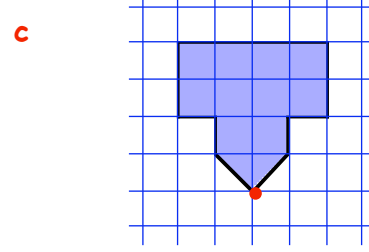
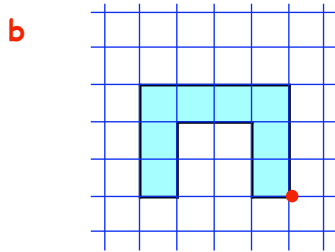
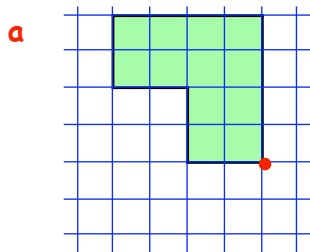

5. Look at the three 8 by 8 squares.

Each has a continuous unbroken line drawn through them dividing the shape into 2 parts in such a way that the shape has half turn symmetry.

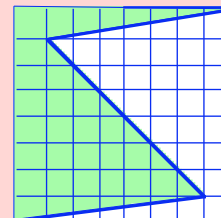
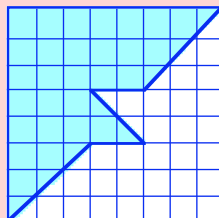
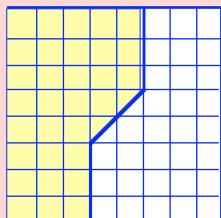

Draw the 8×8 square several times and try to find imaginative ways of dividing the shape with **one** continuous unbroken line such that the shape has half turn symmetry around its centre.

Use two colours to shade each half in and make a display of the best.

Translation (Slide) Symmetry

Shown is a 3 by 2 rectangular tile.

It is easy to see that if you have lots of tiles **congruent*** to this one, you can cover an area using them, with **NO** gaps.

In Mathematics terms, we say :-

"The rectangle tiles the surface".

(or tiles the "plane").

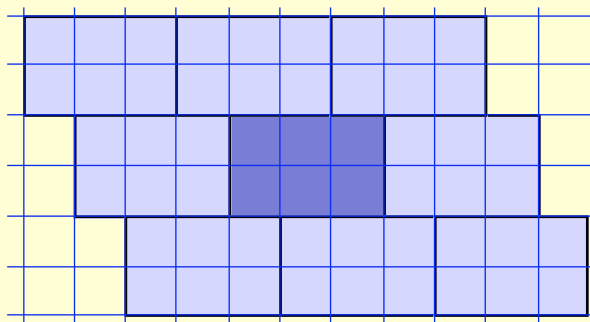

Congruent - two shapes are congruent if they are exactly the same size and shape.

Exercise 4 (You will need $\frac{1}{2}$ cm squared paper).

1. **a** Copy this square (3 by 3) tile onto squared paper. Shade or colour it in as the starter tile.
- b** Completely surround it with congruent tiles to show that the square will "tile the plane".

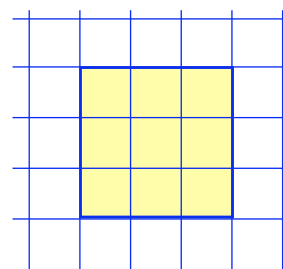

2.

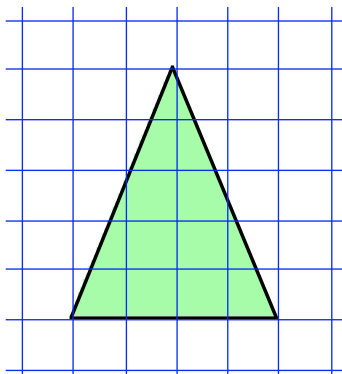

- a** Copy this triangular tile onto squared paper and shade or colour it in.
- b** Completely surround it with congruent tiles to show that the triangle will "tile the plane".

(note :- even if you turn a tile upside down it will still be congruent to the original)

3. **a** Make a copy of this rhombic tile.
- b** Completely surround it with congruent tiles to show that the rhombus will "tile the plane".

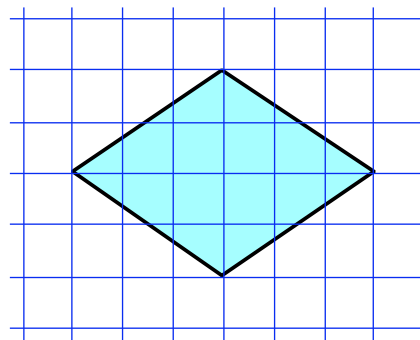

4.

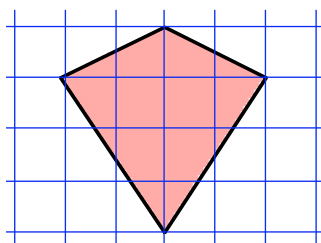

- a** Copy this kite-shaped tile onto squared paper and shade or colour it in.
- b** Completely surround it with congruent tiles to show that the kite will "tile the plane".

5. Shown below are various shapes.

Without actually drawing them, decide which shapes are most likely to "tile the plane".

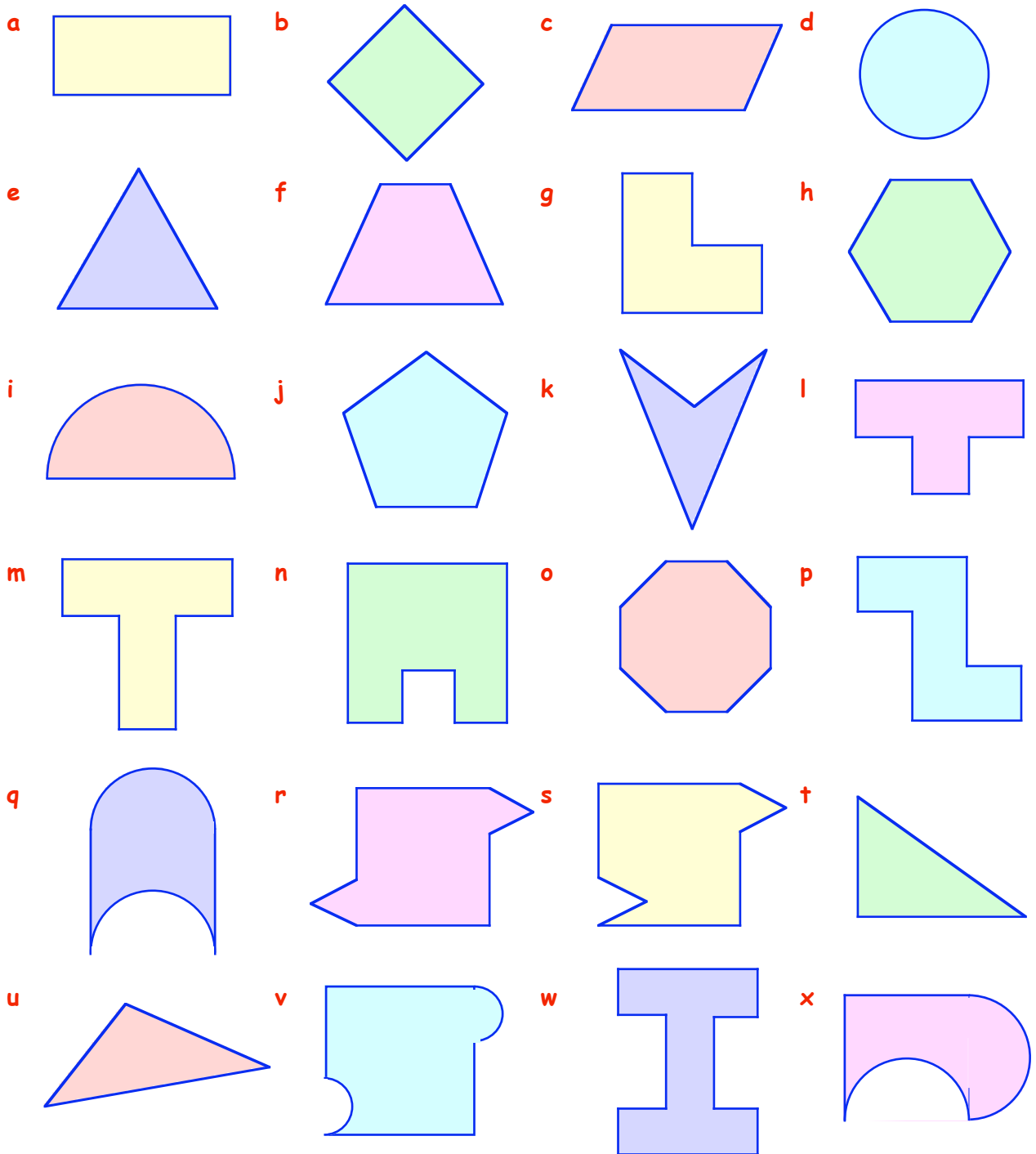

6. This shape is called a V-kite.

- a Copy it carefully and shade it in.
- b Show, by surrounding it with congruent shapes, that the V-kite tiles the plane.

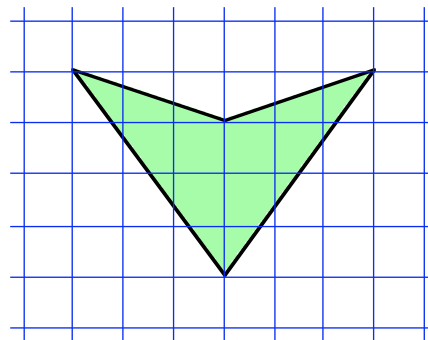

7. Do the same for each of the following.
- Draw each shape and shade it in.
 - Surround each shape completely with a set of congruent tiles.

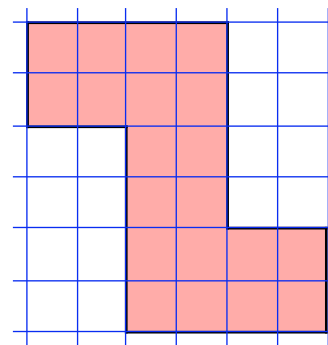
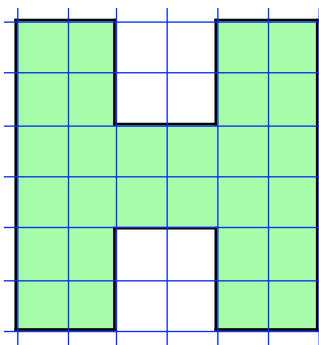
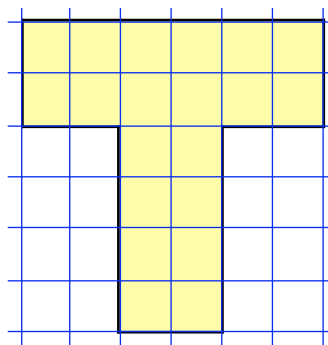

8. This one is a bit trickier.
- Draw the tile carefully, shade it in and surround it with a set of congruent tiles.

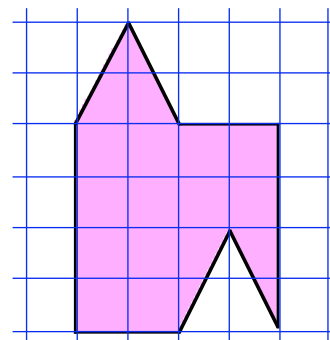

9. Here is how to create your own **FUN** tile :-
- Step 1** Start with a simple shape that does tile, like a square or rectangle.
 - Step 2** Draw it onto cardboard.
 - Step 3** Cut a simple shape (like a triangle) out from the bottom corner.
 - Step 4** Sellotape the triangle on the top corner in the corresponding position.
 - Step 5** This now gives a shape that tiles.

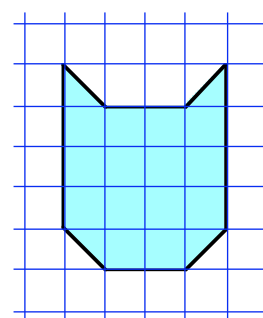
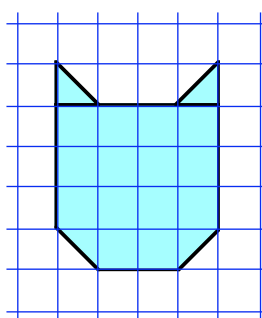
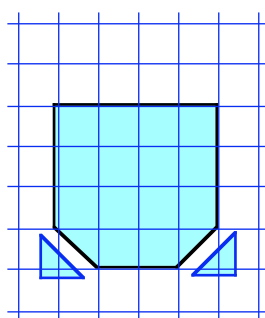
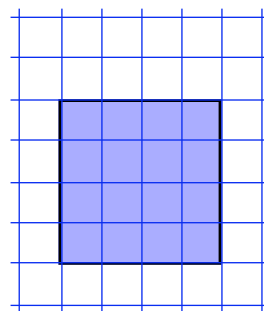

Use your piece of card as a template to draw a pattern of "cat faces".

10. Design your own template. Start with a simple shape like a square, rectangle or equilateral triangle. Draw it on card and cut it out. Use your template to create a repetitive pattern.

Topic in a Nutshell

1. Write down how many lines of symmetry are in each of these shapes :-

a

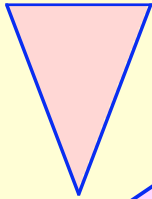

b

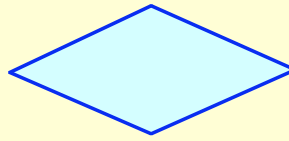

c

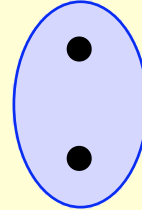

d

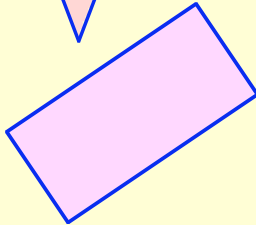

e

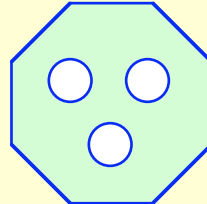

f

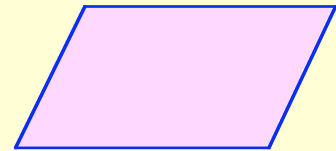

2. Copy these three shapes neatly on to squared paper and complete the diagrams so that the red lines are lines of symmetry :-

a

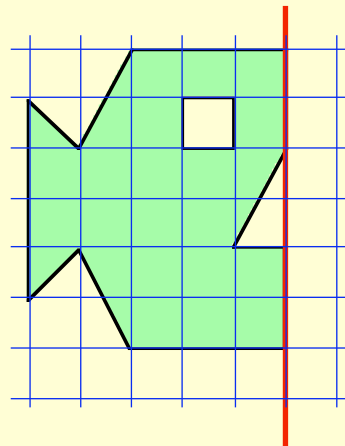

b

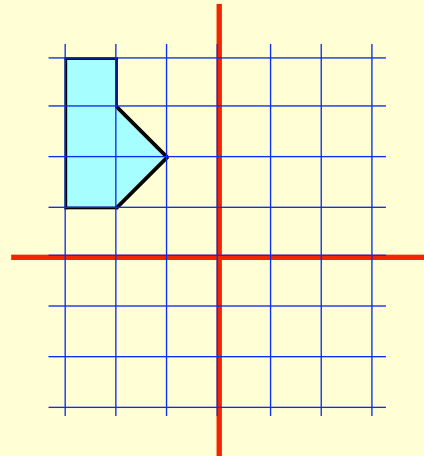

c

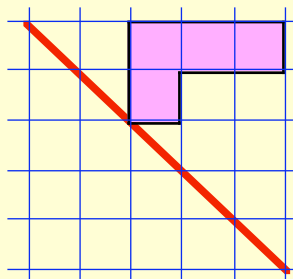

3. Which, if any, of these shapes have half turn symmetry ?

a

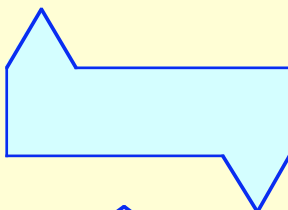

b

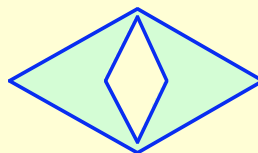

c

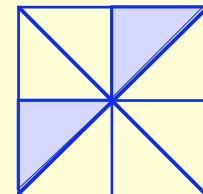

d

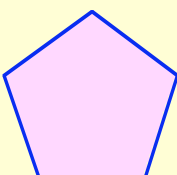

e

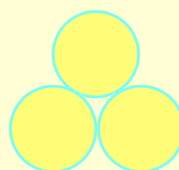

f

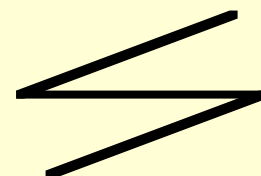

4. Each of the following shapes has rotational symmetry. Say what kind of turn symmetry, ($\frac{1}{2}$, $\frac{1}{3}$, ...), and state the **ORDER** of rotational symmetry.

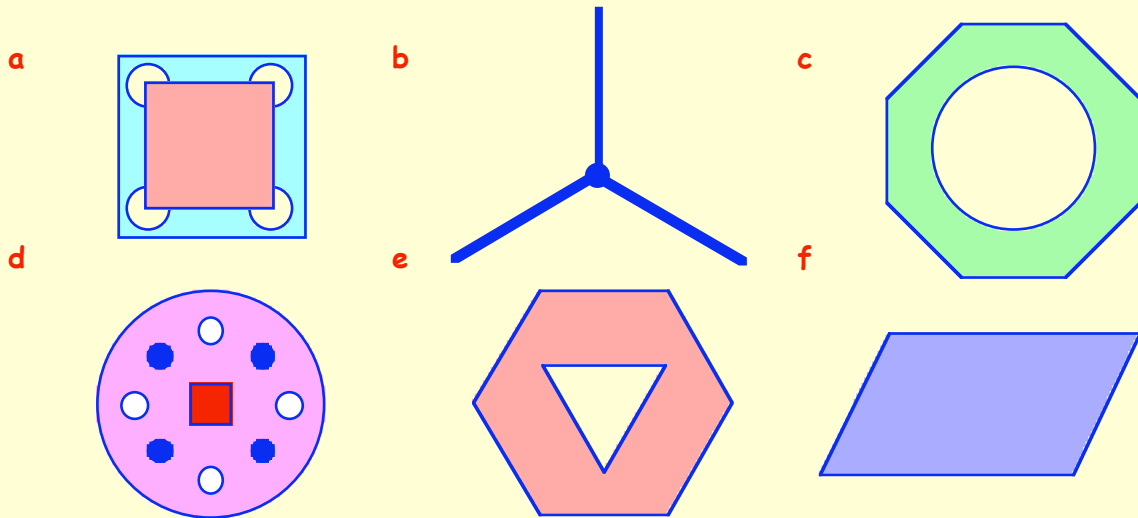

5. Copy these two shapes and give each of them a half turn around the dot.

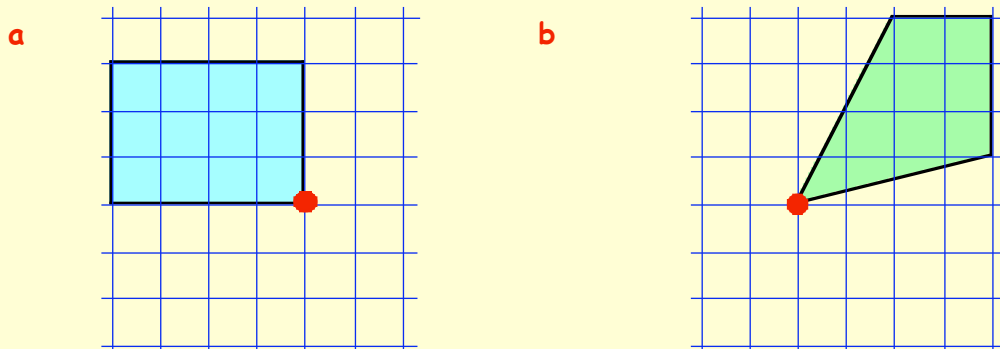

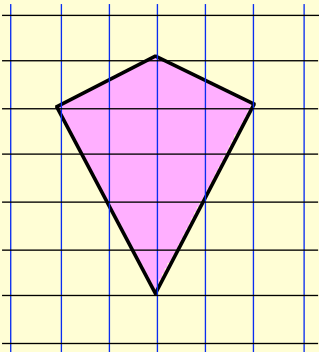
- 6.
- 
- a** Make a copy of this kite-shaped tile in the **centre** of a page in your jotter and shade it.
- b** Show how to completely surround it with congruent tiles.

7. Which of the following tiles will cover the plane?

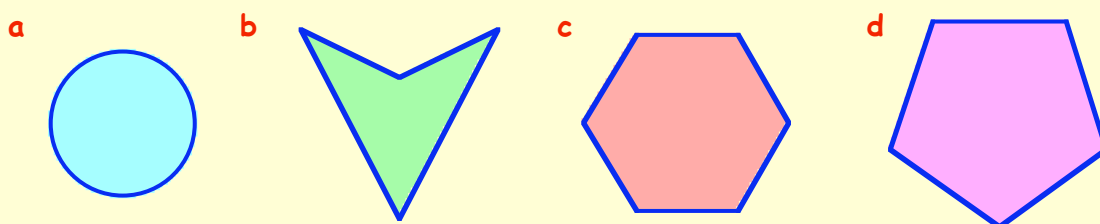

Chapter 8



Tidying up terms

It is possible to "tidy up" expressions by :-

adding all **like** terms.

See the 3 **examples** shown opposite.

$5x + 2x - 4x = 3x$	$7a + 3 + 5a - 1 = 12a + 2$	$6v + w + v = 7v + w$
---------------------	-----------------------------	-----------------------

Exercise 1

1. Copy each of the following and then give a simplified answer below each one :-

- | | | | | | |
|---|-----------------|---|------------------|---|---------------------|
| a | $4x + 6x$ | b | $9x - 3x$ | c | $8x + x$ |
| d | $5x - x$ | e | $7x + 2x + 5x$ | f | $8x + 3x + x$ |
| g | $x + x + x$ | h | $3x + 7x - 9x$ | i | $10p + 6p - 13p$ |
| j | $8v + 5v - v$ | k | $20s - 10s + 6s$ | l | $30h - 20h - h$ |
| m | $e + e - e$ | n | $2w + 7w - 9w$ | o | $9n - 3n - 4n$ |
| p | $15y - y - 11y$ | q | $9g - g - 3g$ | r | $2k - k + 7k$ |
| s | $m + m + m + m$ | t | $p + p + p - p$ | u | $3x + 6x - 8x + 5x$ |



2. Copy each of the following and then give a simplified answer below each one :-

- | | | | | | |
|---|-----------------------------|---|-----------------------------------|---|---------------------|
| a | $4x + 6x + 3x - 4x$ | b | $7a - a + 3a - 5a$ | c | $4v + 2 + 9v$ |
| d | $5x + 7x + 3$ | e | $4w - 1 + 9w$ | f | $5z + 6 + z + 8$ |
| g | $5r + 5 - r - 5$ | h | $6d + 7 - 5d - 7$ | i | $3e + 2f + 7e + 6f$ |
| j | $2a + 3b + 9a + 8b$ | k | $6x + 4y - 3x - y$ | l | $6v + w - v + 7w$ |
| m | $a + a + a + 6b$ | n | $4x + 7x + 1 + 2x$ | o | $7g + 3h + 7g$ |
| p | $2a + b + 5a + b + a + 2b$ | q | $9x + 3y - 8x - 2y + 5x + 6y$ | | |
| r | $5p + 6q + 4 - 3p - q + 12$ | s | $3x^2 + 7x^2 + 2y^2 - 9x^2 - y^2$ | | |



Number Machines

To build an expression from a number machine simply follow the given set of rules.

See the 2 **examples** shown opposite.

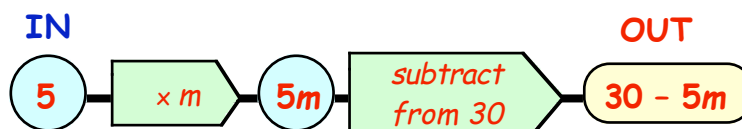
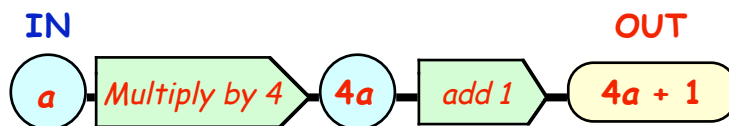

Exercise 2

1. Decide what number comes **out** from these number machines :-

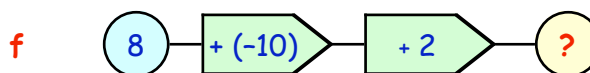
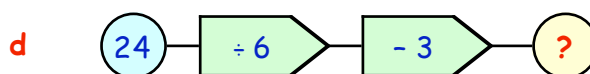
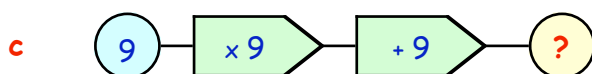
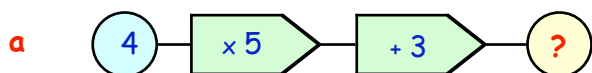

You must **"UNDO"** this number machine to find the value of the number which was **"put in"**.

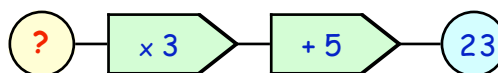

Undo the **"+ 5"** first by **"- 5"**, then undo the **"x 3"** by **"÷ 3"**.

2. Decide what number must have gone **in** each time in these number machines :-

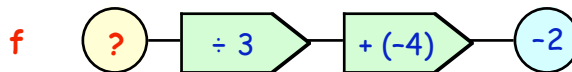
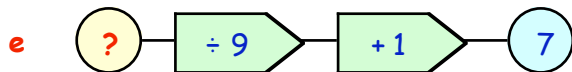
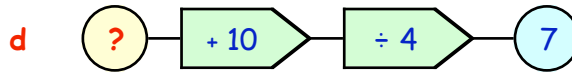
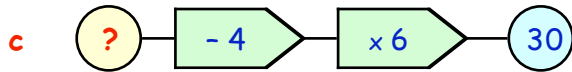
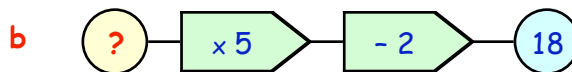
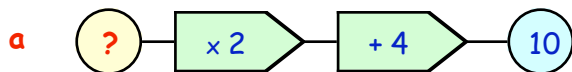

3. Copy each of the following number machines and follow the rules to build up an expression for each one :-

a x multiply by 2 add 5

b y multiply by 5 subtract 1

c a multiply by 9 add 10

d p multiply by 4 subtract **from** 20

e g multiply by 3 subtract 15

f d multiply by 6 subtract 10

g 2 multiply by w subtract 5

h 8 multiply by x subtract **from** 20

i a divide by 4 subtract 3

j 10 divide by p subtract **from** 9

k t divide by 3 subtract **from** p

l s multiply by $\frac{1}{2}$ add x

m h multiply by $\frac{1}{4}$ subtract w

n b multiply by $\frac{1}{5}$ subtract **from** v

Working with Expressions

(Substitution)

Example 1:- If $x = 3$, find the value of :-

$$\begin{array}{ll} \text{(i)} & 4x + 5 \\ & = 12 + 5 \\ & = 17 \end{array} \qquad \begin{array}{ll} \text{(ii)} & 20 - 6x \\ & = 20 - 18 \\ & = 2 \end{array}$$

Example 2:- For $p = 9$ and $q = 6$ find the value of :-

$$\begin{array}{ll} \text{(i)} & 5p - 7q \\ & = 5 \times 9 - 7 \times 6 \\ & = 45 - 42 \\ & = 3 \end{array} \qquad \begin{array}{ll} \text{(ii)} & 30 - 2p + q \\ & = 30 - 2 \times 9 + 6 \\ & = 30 - 18 + 6 \\ & = 18 \end{array}$$

Substitution

$$m = 6 \quad n = 2$$

$$\begin{aligned} & 3m - 5n + 12 \\ & = 3 \times 6 - 5 \times 2 + 12 \\ & = 18 - 10 + 12 \\ & = 20 \end{aligned}$$

Exercise 3

1. If $x = 4$ and $y = 3$, find the value of :-

a	$x + y$	b	$x - y$	c	xy	d	$5x$
e	$10y$	f	$5xy$	g	$2yx$	h	$8y \div 4$
i	$7x \div 2$	j	$4xy \div 6$	k	$xy \div 10$	l	$\frac{x+y}{7}$

2. For $p = 6$ and $q = 8$, find the value of :-

a	$2p + 1$	b	$3q - 4$	c	$20 - 3p$	d	$10 + 5q$
e	$12 - 1.5q$	f	$\frac{1}{2}p + 7$	g	$\frac{1}{4}q - 1$	h	p^2
i	q^2	j	$\frac{p^2}{4}$	k	$\frac{q^2}{64}$	l	$\frac{96}{pq}$

3. For $a = 5$, $b = 1$ and $c = 10$, calculate :-

a	$a + b + c$	b	$2c - a$	c	$2c + b$	d	$a - b + c$
e	$c - 2b + a$	f	$c + 2a - b$	g	$2ab - 1$	h	$3bc - 20$
i	$10 - bc$	j	abc	k	$2ab + c$	l	$7b + ac$
m	$9c - 16a$	n	$\frac{1}{2}c - 10$	o	$\frac{1}{5}a + 9$	p	$\frac{1}{2}b + \frac{1}{2}a$

4. For $r = 3$, $s = 5$, $t = 1$ and $u = 8$, calculate :-

a	$5r + 2 + t$	b	$7 + 2u - 10t$	c	$2s + 4t$	d	$30 - 5s$
e	$u - 2r + t$	f	$r + 2s - u$	g	$2us - 1$	h	$15 - 3rt$
i	$2t + 4r - s$	j	$2u - 4t + 2r$	k	$\frac{1}{5}s + t$	l	$\frac{1}{2}u - tr$
m	$20 - 2u + t$	n	$15 + 3s - 10r$	o	$25 - 5s + u$	p	$50 - 2rs - tu$

5. a Find an expression for the total cost, in pence, of **all** 5 items :-

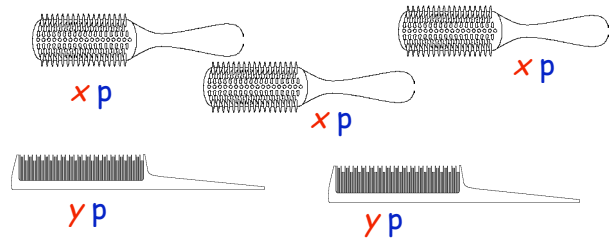

b If $x = 40$ and $y = 25$, what is the **total** cost ?

6. a Find an expression for the total length of the 7 metal rods, in centimetres.

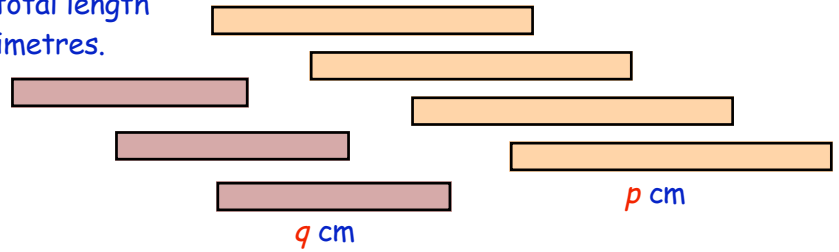

b If $p = 30$ and $q = 20$, what is the **total** length ?

7. A fork weighs f grams and a spoon weighs s grams.

a What is the total combined weight of the forks and spoons shown opposite in grams ?

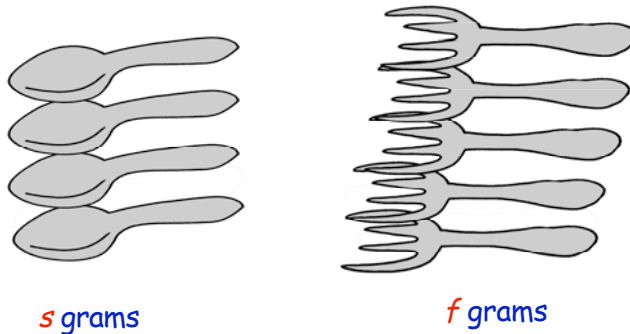

b If $f = 50$ and $s = 65$ calculate the total weight of the 9 items.

8. For $x = 4$, $y = 5$, and $z = 2$, calculate the value of :-

- a $2x^2$ b $xz + y^2$ c $y^2 - 5z^2$ d $3xz + 2xy^2$

9. a Find an expression for the **total** perimeter of this shape in terms of x and y .

b Calculate the perimeter, given that $x = 6$ and $y = 10$.

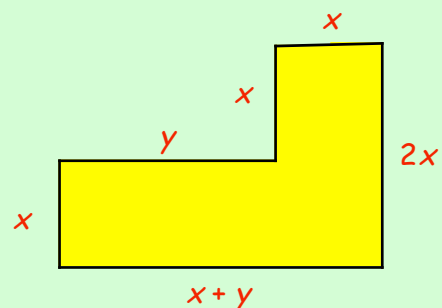

10.

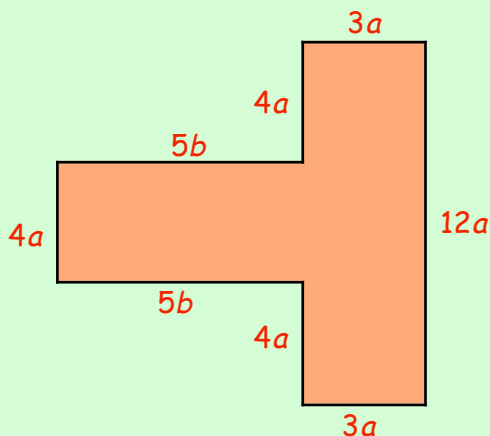

a Find an expression for the **total** perimeter of this shape in terms of a and b .

b Calculate the **perimeter**, given that $a = 1.5$ and $b = 2$.

Solving Equations

Shown opposite are 3 simple equations :-

We refer to the missing value, (the x), as the **variable** in the equation

When we find the value of this variable, we say we have **solved** the equation or found the **solution**.

Look at the solutions in the 3 examples :-

$x + 5 = 9$ $x = 4$	$x - 3 = 12$ $x = 15$
$x - 7 = 1$ $x = 8$	

There are various ways of solving equations :-

- the method of "equal addition"
- the "cover up" method
- the "change side \leftrightarrow change sign" rule.

Discuss the various ways with your teacher.



Exercise 4

1. Copy the equation and find the value of x by solving these equations :-

a $x + 2 = 6$

b $x + 5 = 11$

c $x + 6 = 13$

d $x + 7 = 20$

e $x - 1 = 6$

f $x - 2 = 21$

g $x - 20 = 0$

h $x - 30 = 20$

i $x + 7 = 7$

j $x - 8 = 0$

k $x + 12 = 13$

l $x - 50 = 50$

m $7 - x = 2$

n $4 + x = 9$

o $8 - x = 0$

p $25 + x = 60$

q $14 - x = 11$

r $35 + x = 35$

Remember that $4x$ means $4 \times x$.

Three examples are shown opposite of solving equations involving multiplication.

$4x = 40$ $x = 10$	$7x = 21$ $x = 3$	$9x = 45$ $x = 5$
-----------------------	----------------------	----------------------

2. Copy each equation and find the value of the letter :-

a $3x = 15$

b $4m = 28$

c $5p = 40$

d $7q = 21$

e $6t = 36$

f $8a = 80$

g $3b = 33$

h $8d = 56$

i $2x = 9$

j $2p = 21$

k $4p = 18$

l $6m = 27$

m $10x = 55$

n $8t = 12$

o $14p = 21$

p $20b = 70$

q $100c = 150$

r $2n = 19$

Harder Equations :-

Look at the following equations which involve both addition/subtraction and multiplication.

Your teacher will discuss with you the best way to solve these equations.

$3x + 1 = 13$ $3x = 12$ $x = 4$	$2x - 5 = 7$ $2x = 12$ $x = 6$
$6x - 2 = 28$ $6x = 30$ $x = 5$	

Exercise 5

1. Find the value of x by solving these equations :-

Set down your working carefully.

a $2x + 3 = 5$

b $3x + 6 = 21$

c $4x + 7 = 23$

d $5x + 2 = 42$

e $2x - 4 = 6$

f $3x - 3 = 24$

g $4x - 1 = 35$

h $3x - 6 = 0$

i $6x - 1 = 53$

j $7x - 2 = 68$

k $8x + 4 = 28$

l $9x - 2 = 61$

m $2x - 12 = 2$

n $4x + 10 = 22$

o $5x + 20 = 20$

p $3x - 5 = 55$

q $7x - 7 = 0$

r $2x - 5 = 0$

s $5x - 1 = 24$

t $4x + 5 = 19$

u $6x - 3 = 24$

2. Look at the picture showing 2 rods end to end :-

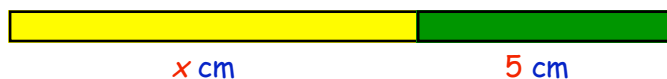

a Write down an expression, in terms of x , for the total length of the 2 rods.

b Given that the total length of the rods is actually 14 centimetres :-

(i) make up an equation involving x .

(ii) solve it to find the value of x .

3. I've got 30p and David told me he has x p. Together we have 42p.

a Make up an equation using this information.

b Now solve it to determine how much David has.

4. There were x marbles in a bag. 7 were removed and I found that there were then 14 left.

a Make up an equation about the marbles.

b Now solve it to determine how many there were to begin with.



5. To find the area of a rectangle you **multiply** its length by its breadth.

a Write down an expression for the area of this rectangle in terms of x .

b If the actual area is 24 cm^2 ,

(i) write down an equation involving x ,

(ii) solve it to find the value of x .

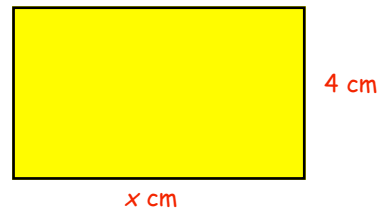

6. Find the value of x in each case :-

a $\frac{1}{2}x = 7$

b $\frac{1}{3}x = 9$

c $\frac{1}{4}x = 20$

d $\frac{1}{5}x = 10$

e $\frac{1}{10}x = 5$

f $\frac{1}{8}x = 12$

g $\frac{1}{6}x = 11$

h $\frac{1}{5}x = 20$

i $\frac{1}{2}x = 3\frac{1}{2}$

j $\frac{1}{2}x + 1 = 6$

k $\frac{1}{3}x - 4 = 2$

l $\frac{1}{4}x - 8 = 1$

m $\frac{1}{2}x - 2 = 1$

n $\frac{1}{5}x + 1 = 3$

o $\frac{1}{10}x - 10 = 10$

Solving Simple Inequalities

The equations you were solving were called **equations** because they each had the "=" sign in them.

There are 4 other mathematical signs, called **inequalities** and they are :-

> "greater than"	≥ "greater than or equal to"
< "less than"	≤ "less than or equal to"

Examples :-

$5 > 3$	"five is greater than three"
$-7 < -6$	"negative seven is less than negative six"
$x \geq 2$	"x is greater than or equal to two" (x can be 2 or any number above 2)
$y \leq -5$	"y is less than or equal to negative five" (y can be -5 or any number below -5)

Have you noticed ?? - The arrow (<), (>) always points to the smaller number.

$7 > 3$

smaller

$-6 < -4$

smaller

Exercise 6

1. **COPY** the following as shown and place a "<" sign or a ">" sign between the numbers :-

a 2 ... 5

b 7 ... 6

c 0 ... -2

d -2 ... -1

e 1 ... -8

f -7 ... -15

g -3 ... 0

h -5 ... -4

i -52 ... -49

j -16 ... -17

k -100 ... -101

l 12 ... $11\frac{1}{2}$

2. Rewrite the following pairs of numbers to suit the given sign :-

Example :- write 5 and 4 using a "<" sign. \Rightarrow answer is :- $4 < 5$.

Write :-

a 9 and 8, using "<"

b 7 and 2, using ">"

c 15 and 13, using "<"

d -9 and -6, using ">"

e -1 and 1, using ">"

f 4 and -2 using, "<"

g -22 and -21, using "<"

h -54 and -55, using ">"

i 3 and -3 using, "<"

3. In this question you must choose x only from the numbers 0, 1, 2, 3, or 4.

Examples :-

$x \geq 1$ gives $x = 1, 2, 3, 4$.

$x < 3$ gives $x = 0, 1, 2$.

a $x > 2$

b $x < 4$

c $x \geq 3$

d $x \leq 1$

e $x > 0$

f $x < 4$

g $x > 4$

h $x \geq 0$

i $x \leq 4$

4. In this question you must choose y only from the numbers, -3, -2, -1, 0, 1, 2.

a $y > 1$

b $y < 0$

c $y \geq -1$

d $y \leq 2$

e $y > -3$

f $y \leq -2$

g $y > -2$

h $y < 1$

i $y \geq -3$

5. Solve these inequalities, by taking each value from the given list and checking to see if it works :-

Inequality	Numbers chosen from	Inequality	Numbers chosen from
a $2a > 6$	{1, 2, 3, 4, 5}	b $4b < 20$	{1, 2, 3, 4, 5}
c $c + 4 < 7$	{0, 1, 2, 3, 4}	d $d - 5 > 0$	{2, 3, 4, 5, 6, 7}
e $4e + 2 \geq 6$	{0, 1, 2, 3}	f $3f - 1 \leq 6$	{-1, 0, 1, 2, 3, 4}
g $15 - g \geq 12$	{1, 2, 3, 4, 5, 6}	h $15 - 2h \leq 11$	{0, 1, 2, 3, 4, 5, 6}
i $3p > 2$	{-1, 0, 1, 2, 3}	j $\frac{1}{2}j \leq 1$	{-2, -1, 0, 1, 2, 3, 4, 5}

6. For each of the following given statements, make up your own inequality :-

Example :-

the **maximum** crowd (C) at McDermid Park, Perth is set at 10 000.

= >

$$\text{So } C \leq 10\,000$$

a The maximum permitted crowd (C) at Easter Road is set at 38 000.

=> so C

b Voters have to be 18 years old or over.
Brian is Y years old and **can** vote. So ...

c The maximum number of passengers on a minibus is 16.
There were P people on the minibus. So

d The speed limit outside school buildings is now 20 mph.
Cheryl was booked for speeding outside Langbank Primary.
She was travelling at S mph. So

e The cost of a disco ticket is £4. Beryl has £ M .
She has got at least enough money with her to buy one. So

f To win a golf competition Nick required a score of 66 or less.
He didn't win! He took a total of T strokes. So

g In a spelling test out of 20, a mark of 18 was regarded as a good pass.
Charles got a good pass. He scored M marks out of 20. So

h To heat pies in an oven requires the oven to be set at 220°C for 30 minutes.
Sally had put pies in the oven for 30 minutes but had totally burned them.
The oven temperature for the 30 minutes was T (°C). So

i A computer game costs £40.
Mary has £ x . Sid has £ y . By putting their money together they find that they have **more** than enough to buy the game. So ...



Solving Inequalities

To solve an **inequality**, you use the same technique used to solve an equation.

Look at the three **examples** shown :-

Comparing :-

$$\begin{array}{l} x + 5 = 9 \\ x = 4 \end{array}$$

to

$$\begin{array}{l} x + 5 < 9 \\ x < 4 \end{array}$$

$$\begin{array}{l} x + 3 < 11 \\ x < 8 \end{array}$$

$$\begin{array}{l} x - 5 > 6 \\ x > 11 \end{array}$$

$$\begin{array}{l} x - 9 \leq 4 \\ x \leq 13 \end{array}$$

Exercise 7

1. Solve these inequalities, leaving your answers as in the worked examples shown on the last page, i.e. $x > 3$, etc. :-

a $x + 1 > 3$

b $x + 4 > 9$

c $x + 7 \leq 8$

d $x + 9 < 16$

e $x - 2 \leq 7$

f $x - 10 \geq 21$

g $x - 15 > 0$

h $x - 30 < 40$

i $x + 3 \leq 3$

j $x - 6 \geq 0$

k $x + 19 < 20$

l $x - 30 > 30$

m $x + 2 \cdot 1 < 3 \cdot 2$

n $x - 105 > 95$

o $x + \frac{1}{2} < 1$

p $9 + x > 11$

q $4 + x \geq 11$

r $31 + x < 35$

The equations like " $4x < 24$ " are tackled the same way as the **equivalent equation**.

$$\begin{array}{l} 3x < 30 \\ x < 10 \end{array}$$

$$\begin{array}{l} 6x > 18 \\ x > 3 \end{array}$$

$$\begin{array}{l} 8x \leq 40 \\ x \leq 5 \end{array}$$

2. Solve each inequality, leaving your answers as in the worked examples shown above, i.e. $x > 3$, etc. :-

a $3x < 18$

b $4x > 24$

c $5x < 35$

d $6x \geq 48$

e $7x \leq 49$

f $9x > 90$

g $8x < 32$

h $10x \leq 80$

i $4x > 0$

j $12x \geq 12$

k $2x < 9$

l $2x > 17$

m $3x > 4 \cdot 5$

n $8x \leq 160$

o $14x \geq 140$

p $3x < 24$

q $2x > 13$

r $5x \leq 25$

These are **Level F** questions, but if you understood the equivalent equations, (see Exercise 5), then you might be able to tackle them :-

$$\begin{array}{l} 3x + 2 < 20 \\ 3x < 18 \\ x < 6 \end{array}$$

$$\begin{array}{l} 4x - 5 > 7 \\ 4x > 12 \\ x > 3 \end{array}$$

$$\begin{array}{l} 5x - 6 \leq 24 \\ 5x \leq 30 \\ x \leq 6 \end{array}$$

3. Find the value of x by solving these inequalities :-
Set down your working carefully.

a $3x + 2 < 14$

b $2x + 5 > 13$

c $5x + 1 < 1$

d $4x + 2 \geq 34$

e $6x - 1 \leq 23$

f $5x - 16 > 39$

g $8x - 8 \leq 0$

h $4x - 6 < 6$

i $9x - 2 > 52$

j $10x - 3 \geq 57$

k $7x + 10 < 45$

l $6x - 11 \leq 55$

m $5x - 12 \geq 3$

n $9x + 10 < 10$

o $2x + 7 \geq 12$

Topic in a Nutshell

1. Copy each of the following and give a simplified answer each time :-

a $3x + 7x$

b $5x + 3x + x$

c $x + x + x$

d $12x - x - 8x$

e $4x + 6x - 9x + x$

f $2x + 7x - 1$

g $3x + 5 - 2x + 1$

h $x + x + x + y$

i $2a + 5b - a - b$

j $4x + 2y - 3x + y - 6$

k $8x^2 + 4y^2 + x^2 - 3y^2$

l $3x^2 + 4x + 2x^2 - 3x$

2. In each case, decide what number the ? represents :-

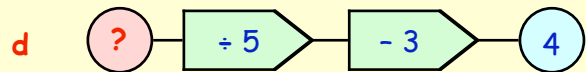
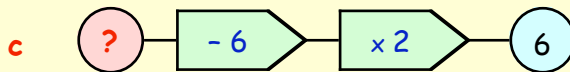
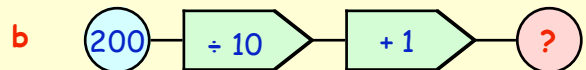
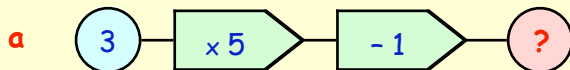

3. Write a number machine for each of the following :-

a "a multiplied by 2, added on to b".

b "x divided by y, subtracted from 20".

4. If $x = 1$, $y = 2$, $z = 3$ and $w = 10$, find the value of :-

a $3x + 4y$

b $w - 3x$

c $10w - 1$

d $5z + 2y + 3$

e $30z - 4w + 5z$

f $80 - 10xy + zw$

g $w^2 - x^2$

h $6x^2 - y^2 - 2$

i $10xyzw$

5. a Find an expression for the **total** perimeter of this shape (in cm) in terms of p and q .

b Calculate the perimeter when :-

$p = 6$ and $q = 3$.

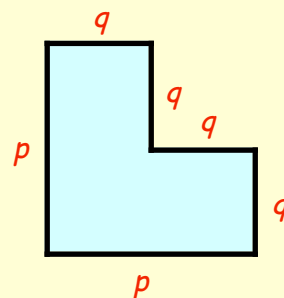

6. Copy each of the following and find the value of x by solving the equation :-

a $x - 9 = 2$

b $x + 15 = 18$

c $7x = 49$

d $2x + 4 = 14$

e $9x - 1 = 44$

f $7x + 5 = 5$

g $\frac{1}{5}x = 8$

h $\frac{1}{3}x = 10$

i $\frac{1}{2}x + 3 = 7$

7. There are x chips on my plate to begin with.
After eating 12 chips, I count that I have only 3 left.



- a Make up an equation about the chips involving x .
- b Solve the equation to find out how many chips were on my plate originally.

8.



A submarine is built to go down to a maximum depth of 80 metres.

This submarine submerged to a depth of D metres and was not in any danger.

=> So

9. Copy the following exactly as shown and put a "<" sign or a ">" sign between the numbers :-

a $7 \dots 12$

b $2 \dots -9$

c $-7 \dots -6$

d $-60 \dots -61$.

10. In this question, you must only choose m from this list of numbers :-

$$\{-2, -1, 0, 1, 2, 3\}$$

Write down the solutions to each of the following from the above acceptable list

a $m \leq -1$

b $m > 1$

c $m \geq 1$

d $m < 3$.

11. Make up an inequality for the statement :-

"The cost of a cup final ticket is £20".

John has £ T but still does not have enough money to buy a ticket "

=> So



12. Solve the following inequalities :-

a $x + 7 > 11$

b $x - 2 \leq 8$

c $x - 3 \geq 3$

d $7x \geq 21$

e $5x < 45$

f $2x > 15$

g $2x + 1 < 7$

h $5x - 10 > 40$

i $8x - 2 < 22$.

Chapter 9



Using The Mean to Compare Data

The **Mean** (or average) of a set of scores is found by

- **adding** all the scores together
- then **dividing** by the number of scores.

$$\text{Mean} = \frac{\text{total of all the scores}}{\text{number of scores}}$$

In any example you do, you should always show how you added the set of numbers first, then show your division.

$$\text{Range} = \text{highest} - \text{lowest}$$

Example :- Find the mean of the **four** numbers, 5, 6, 2 and 7

$$\text{Mean} = \frac{5 + 6 + 2 + 7}{4} = \frac{20}{4} = 5 \quad \text{Range} = 7 - 2 = 5$$

Exercise 1

1. Find the **Mean** and **Range** of :-

- a 4, 6, 8, 10.
- b 11, 23, 14, 20, 27.
- c £5, £8, £11, £29, £23, £2.
- d 13 km, 22 km, 40 km, 28 km, 18 km, 35 km.
- e 9.2, 7.1, 6.7, 9.4, 9.8, 6.9, 10.1, 4.6, 7.3.
- f 9.85, 8.76, 7.93, 11.86.

2. Karen is a student at Stirling University. During the summer months she helps the groundsman at Forthbank Stadium, home of Stirling Albion.



If she gets paid a total of £422.72 for the months of June, July, August and September, how much does this **average out at** per month?

3. Daisy buys 10 packets of Gelly's jelly beans.

She finds that they contain the following number of jelly beans.

30, 32, 34, 32, 35, 31, 33, 30, 34, 34.



- a Calculate the **mean** number of jelly beans (correct to 1 decimal place).
- b The Gelly Company say that each packet of their product should have an average of 34 jelly beans. Should Daisy complain to the company? (*explain*)

4. The journey times (in minutes) of a selection of buses travelling from Inchinnan Bus Garage to Braehead Shopping Centre are shown below :-

6 7 8 9 7 6 10 6 6 7 8 6 7 9 7 25 6



- a Calculate the **mean** time for the journeys (correct to 1 decimal place).
- b One bus took much longer than the mean time - which one - suggest a reason.

5. Baseball players use the **mean** when calculating their average number of runs.

- a Brad scored a **total** of 300 runs in his 4 innings (4 games). Find his **mean** number of runs per inning.
- b He scored only 35 runs in his next innings. Calculate his new **mean** for the 5 innings ?



6. In an ice-skating competition the marks given by the judges of eight countries were as follows :-

6.8 6.8 6.1 6.4 6.2 6.8 6.6 6.7

- a Find the **mean** mark and the range.
- b How many marks below the mean was the lowest mark awarded ?



7. J.R. Harvey buys boxes of worms for fishing. The weight of each box is roughly the same, but the number of worms in each box tends to vary.

Here are the number of worms which were in his last batch of boxes :-

9 4 11 12 8 5 7 9 7 8 17 5 10

- a Calculate the **mean** number of worms per box and the range.
- b Relative to the mean, comment on the large number of worms in one particular box.



8. Arnold's Hire Co. and Clarks Autos both offer limousines for hire.

The cost of a day's hire for different ranges of limos are shown in the table.

Calculate the **mean** cost for a limo for each hire company and determine which one is the cheaper, on average.

<i>Arnold's</i>	<i>Clark's</i>
£102	£114
£115	£118
£124	£120
£135	£124
-	£132



9. The staff of a school run a sweepstake on how long the headteacher's speech will last at the annual prize-giving.

For the ten year's before he retired the headteacher's speech times, in minutes, were :-

20.5 24.5 23 8.5 22 23.5 26.5 24.5 19.5 22.5

- a Calculate his **mean** time, correct to 1 decimal place.
- b One year, he was not feeling too well. How many minutes below the mean did his speech last that year ?



10. Mr Gee likes steaks. He spent six days in Tenerife dining out, eating his favourite dish each day and recording the cost in £'s.

On returning home, he spent 4 days touring Scotland, still requesting his favourite platter. Again, he recorded the price of his daily meal.



The costs are shown in the table :-

Mr Gee's Steaks						
Tenerife	£4.50	£5.80	£3.90	£4.80	£6.30	£5.00
Scotland	£12.50	£14.75	£15.80	£11.95		

- a Calculate the **mean** cost per steak dinner for each country.
- b How much more expensive, on average, is a steak dinner in Scotland than in Tenerife ?
11. The length of tracks (in minutes) on two CD's are listed below.

Kylie "Fever"	3.4	3.6	3.4	4.0	3.5	3.6	4.0	4.1	3.7	3.2	4.2				
Kiljoy - "Disco"	4.1	3.0	3.3	3.1	3.5	3.4	4.1	3.6	3.3	3.7	4.0	3.4	3.6	3.3	3.5

- a Calculate the **mean** length of a song on Kylie's CD.
- b Calculate the **mean** length of a song on Kiljoy's CD.
- c The longest track is Kylie's "Burning Up". How long did it last ?
12. The distances for the first 9 holes at Renfrew Golf Club and the Old Course, St Andrews are shown in the table.

Hole No	Renfrew	St Andrews
1	356	370
2	485	411
3	215	352
4	456	419
5	435	518
6	420	374
7	175	359
8	419	166
9	549	307

The lengths are in yards.

- a Calculate, to 1 decimal place :-
- (i) the **mean** length per hole at Renfrew.
- (ii) the **mean** length per hole at St Andrews.
- b the longest hole is Renfrew's 9th.
How much longer is this hole than the **overall** mean at both courses ?

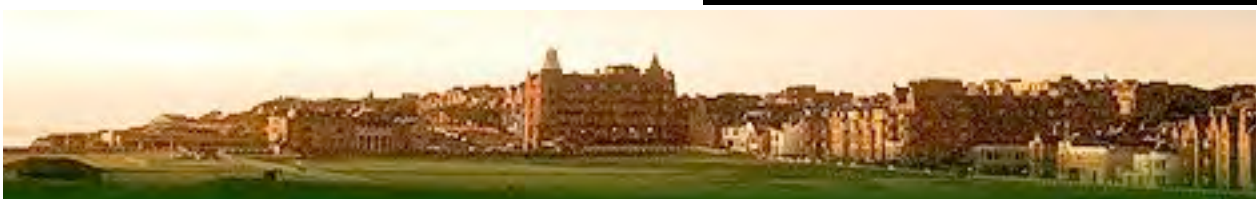

13. Vince set up his mobile catering van across the road from a building site.

The plan was to attract the workers there to buy food from his van over a period of 10 weeks.

For the first 5 weeks Vince used margarine on his sandwiches and for the second 5 weeks he tried to increase sales by using butter.

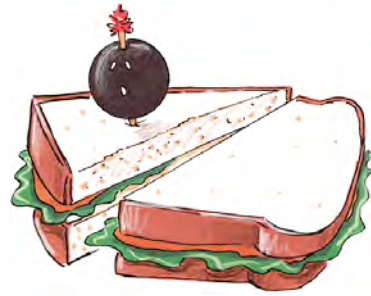

The table below shows how many customers he attracted over a 10 week period.

	<i>margarine</i>					<i>butter</i>				
Week No.	1	2	3	4	5	6	7	8	9	10
No. of customers	240	280	300	240	230	220	250	290	350	370

- a Calculate the **mean** number of customers each week when using :-
 (i) margarine (1st 5 weeks) (ii) butter (2nd 5 weeks).
- b By changing to "buttering" his rolls did Vince find it made a difference ? Explain.
14. The mean weight of two boys is 50 kilograms.
 If Jack weighs 55 kilograms, what must Victor weigh ?

15. The **mean** number of words in the first 2 sentences of a book is 24.
 If the first sentence contains 21 words, how many words were there in the 2nd sentence ?



16. The **mean** age of three girls, Ann, Jean and Gail, is 11.
 Ann is age 14. Jean is aged 10.
 How old must Gail be ?

17. The **mean** number of Playstation Games owned by four boys is 12.
 Davie has 6 games, George has 15 and Toni has 11 games.
 How many games must the 4th boy, Andy, have ?

18. Roderick was absent on the day his class sat a geography test.
 Without him, the **mean** mark for the other 25 pupils was 20,
 but when his mark was included later on, the new mean for the 26 pupils was down to 19.5.



Calculate :-

- a the total of the 25 marks without Roderick.
 b the total of the 26 marks with Roderick's included.
 c the mark which Roderick scored.

Raw data can often appear untidy and difficult to understand.

Organising such data into tables (called **frequency tables**) can make it easier to comprehend.

Exercise 2

1. A tomato grower ideally wants his tomatoes to have a diameter of 60 mm, but he is satisfied if his tomatoes have a diameter ranging from 58 mm to 62 mm.



The diameters, in millimetres, of his early crop were as follows :-

58	51	55	57	53	56	54	62	55	52	58	59
56	52	64	59	55	58	51	62	53	58	59	62
60	52	60	51	56	59	60	51	56	55	62	59
63	58	60	61	52	58	55	62	55	52	58	60

diam	tally	frequency
51		...
52		...
53
54
...

- a Organise the data into a frequency table using tally marks.
 b How many tomatoes were within the range set by the tomato grower ?

2. The table below gives the list of flowers which took first prize at the annual Abercorn Floral Show from 1982 to 2002. Some years, the judges awarded a tie between 2 particular varieties.



1982 Pansy	1989 Petunia	1996 Petunia & Geranium
1983 Petunia	1990 Geranium	1997 Pansy
1984 Impatiens	1991 Geranium	1998 Pansy
1985 Petunia & Impatiens	1992 Marigold	1999 Petunia
1986 Marigold	1993 Pansy	2000 Marigold
1987 Impatiens	1994 Pansy	2001 Pansy
1988 Petunia	1995 Petunia & Marigold	2002 Marigold

Make up your own frequency table to show how many times each flower has either won or shared the first prize.

3. The Primary 7's in a school recorded their shoe sizes which are shown in the table below.

2	4 1/2	4	2 1/2	6	3 1/2	3	4	4	3 1/2
4	4	6 1/2	4	4	6	3 1/2	4	3	4 1/2
3 1/2	4 1/2	2 1/2	5	3 1/2	5	4 1/2	3	6	4
4 1/2	4	5	3 1/2	5	4 1/2	3	6 1/2	3 1/2	7

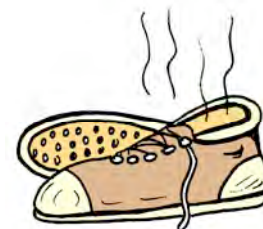

Shoe Size	Tally Mark	Frequency
2		
2 1/2		
3		

- a Make a frequency table similar to the one shown opposite.
 b How many children had a shoe size **bigger** than a "5".

4. Results from last year's Standard Grade History exam in Ainsworth High were :-

- Class 4 H1 - 25 Grade **1's** & 5 Grade **2's**
 4 H2 - 12 Grade **1's** & 7 Grade **2's** & 8 Grade **3's**
 4 H3 - 17 Grade **3's** & 2 Grade **4's** & 5 Grade **5's** & 1 Grade **6's**
 4 H4 - 0 Grade **3's** & 5 Grade **4's** & 10 Grade **5's** & 3 Grade **7's**
 4 H5 - 8 Grade **6's** & 4 Grade **7's**

- Construct a frequency table which shows the total number of grades 1, 2, 3, 4, 5, 6 and 7's in a more organised way.
- How many grades 1 - 3 were there ?
- How many pupils sat the History exam at Ainsworth High ?

5. A batch of matchboxes is opened and the number of matches in each box is counted. the result is shown in the table below.

38	42	41	42	41	41	39	41
40	41	39	44	41	44	40	41
41	40	42	41	40	42	42	44



- Make a frequency table to show how many matches were in each box.
- How many of the sample agreed with the manufacturer's claim ?

6. The cost of a car ferry trip depends on your vehicle and when you travel. Look at these 2 tables :-

	mid night	5am	8am	noon	7pm	mid night
1 Jan - 31 May						
1 June - 31 Dec						

	Single Fare £			Weekly Return £		
Car	58	85	92	74	100	154
Lorry	88	95	97	84	113	170



- What does it cost for a single car journey at 7am on 1st March ?
- What does it cost for a weekly return for a lorry at 10am on 1st August ?
- A lorry driver pays £97 for a single journey in July.
Between which times can he use the ferry during the day ?
- A lorry driver pays £84 for a weekly return journey in November.
Between which times can he use the ferry during the day ?

7. Pupils in 1st year were asked to name their favourite pop-group.

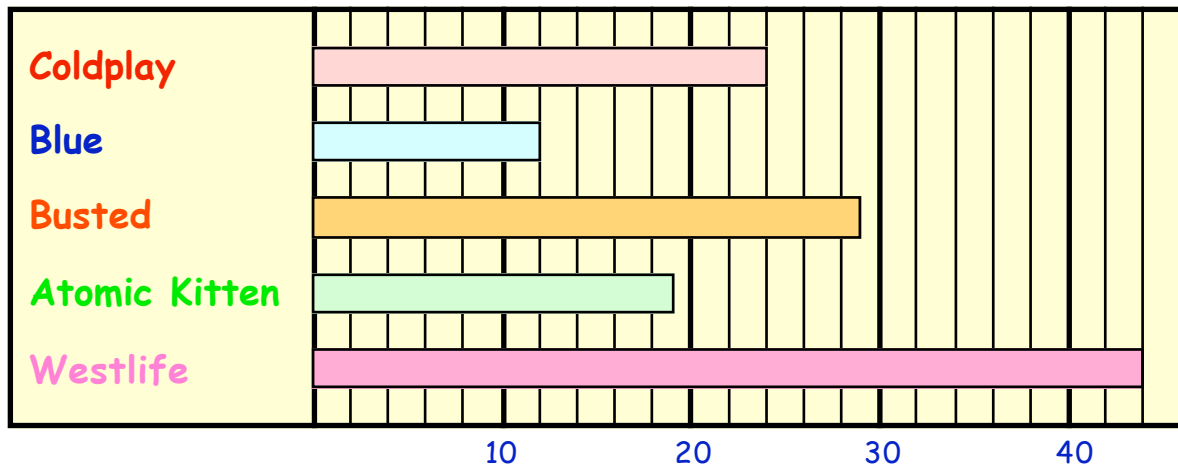

- a How many 1st year pupils liked (i) Coldplay (ii) Atomic Kitten ?
- b How many **more** of them preferred West Life to Atomic Kitten ?
- c How many pupils took part in the survey ?

8. After a month in secondary school, a group of First Year pupils were asked to name their favourite subject.

Subject	Maths	English	Science	P.E.	Music	French
Number	18	7	12	6	10	2

Draw and Label a neat **bar-graph** to represent this information. (Remember to use a RULER or straight edge to draw the lines).

9. Pupils were asked to name their favourite fruit.

apple apple banana orange apple banana apple apple
 banana orange apple banana pear grapes banana orange
 apple banana grapes grapes apple grapes grapes banana
 pear apple banana banana grapes apple apple grapes

- a Copy this frequency table and use tally marks to help complete it.
- b Now draw and label a neat **bar-graph** to help represent this information.

Fruit	Tally	Frequency
apple		
orange		
banana		
grapes		
pear		



Line Graphs

Exercise 3

1. A hospital auxiliary took a patient's temperature every hour from 6 am until 1 pm. The results are shown in this line graph.

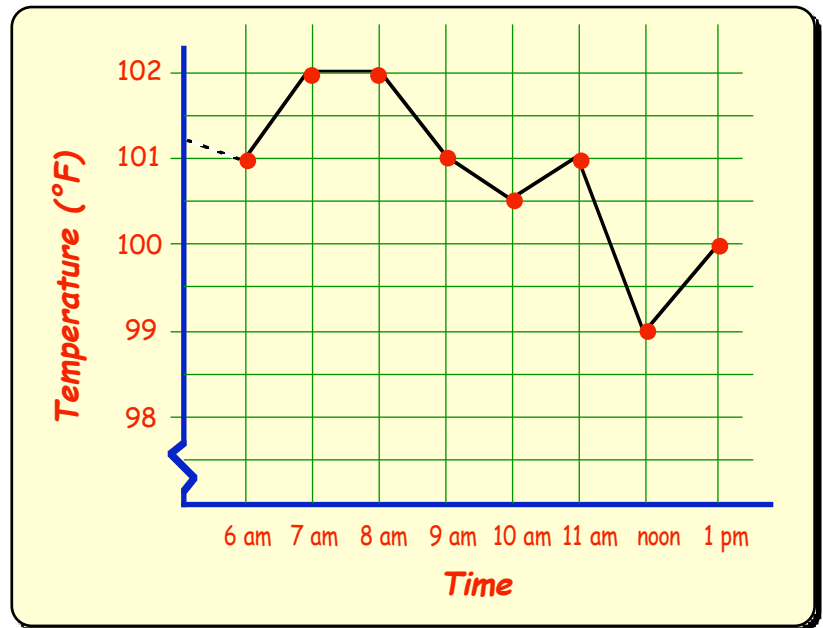

- When was the patient's temperature at its **lowest** ?
- When was it at its **highest** ?
- By how many degrees did it fall between 11 am and noon ?
- At which three times did the temperature begin to rise ?
- Estimate** the patient's temperature at 11:30 am.



2. The comparative line-graph shows the number of children who had the flu or a cold during one week in the winter of 2001.

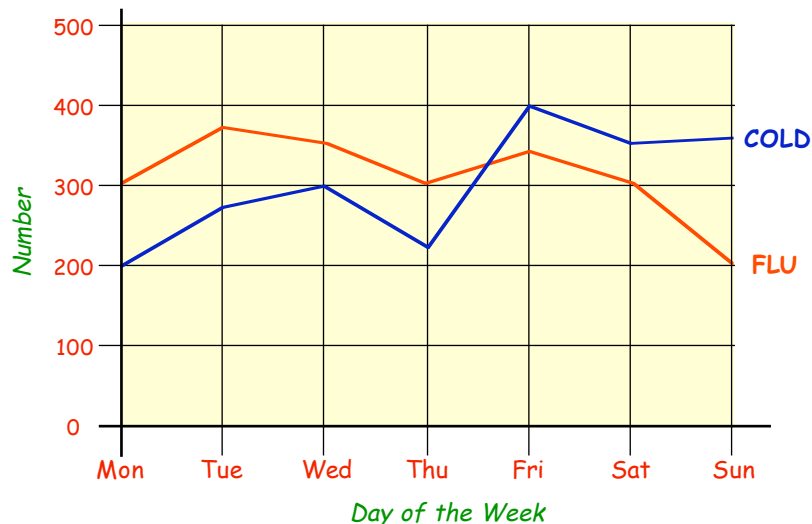

- Write down on which day there were :-
 - more than 350 children with flu **and** less than 300 with the cold.
 - more than 375 children with the cold **and** less than 350 with flu.
 - less than 300 children with flu **and** more than 300 with the cold.
- Between which 2 days was there the **largest difference** between flu and cold.

3. The temperature was carefully recorded in Palma Nova in Majorca one day from 1200 until 1600.

The table shows the results.

TIME	1200	1300	1400	1500	1600
temp °C	26.2	24.4	22.1	20.8	20

- a Make a copy of the graph, on 2 mm graph paper, plot the points and join them up.
- b State between which two times the temperature fell the fastest.



4. "Henderson's Bros of Edinburgh" keep a record of umbrella sales over a one year period.

Month	Jan	Feb	Mar	Apr	May	Jun	Jul	Aug	Sep	Oct	Nov	Dec
Sales	20	16	5	18	7	1	0	4	10	13	18	15

- a Draw a neat labelled **line graph** to show the sales figures.
- b There was a sharp rise and fall at one point of the year. During which month? Can you explain why?
5. The table shows the average heights of boys and girls in a Port Glasgow Karate Club.

Age	6	8	10	12	14	16	18	20
Boys (cm)	120	126	134	140	160	180	180	182
Girls (cm)	120	128	130	140	154	160	175	178

- a Using the scale shown, draw a comparative line graph.
- b At what ages are the average heights the same?
- c At what age are the average heights of the girls greater than those of the boys?
- d At what age are the difference in heights the greatest?

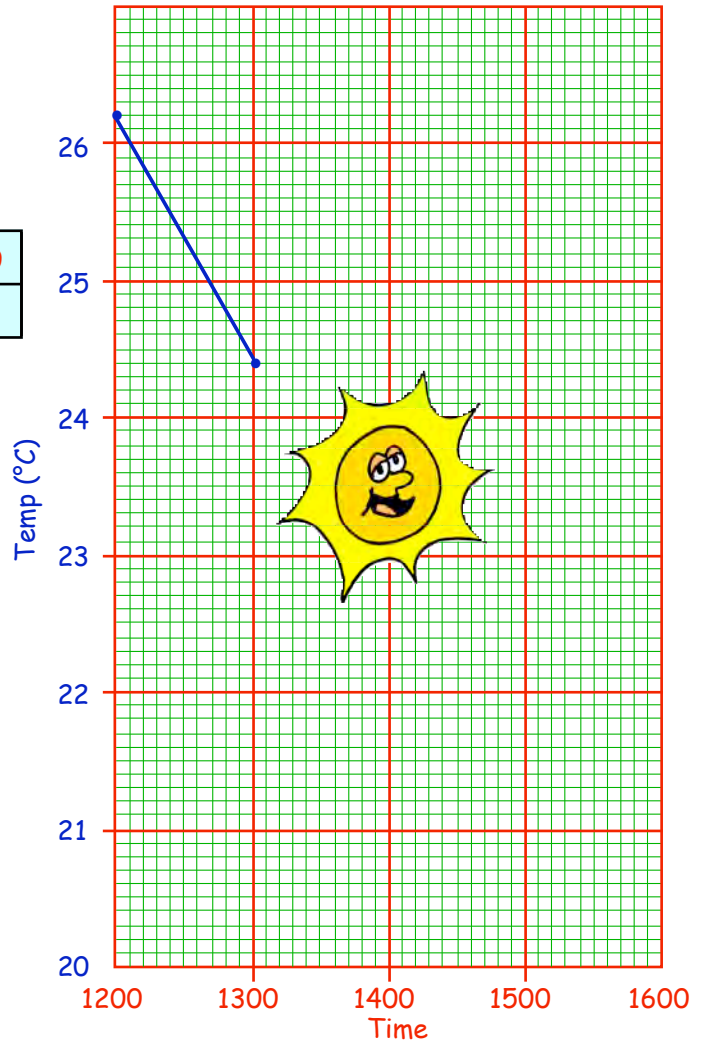
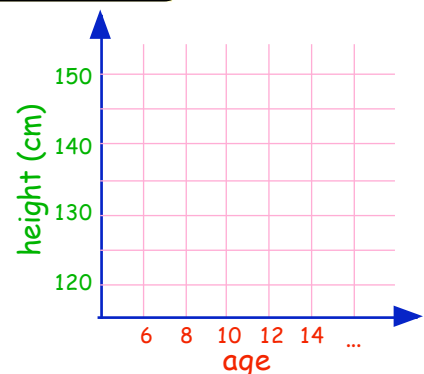

Pie Charts

A Pie Chart is a diagram used to represent statistical data.

Simple Percentage Pie-Charts

The pie chart opposite has been divided into 10 equal "sectors".

=> Each "bit" stands for $100 \div 10 = 10\%$

The pie chart represents the results of a survey into favourite daily newspaper.

favourite paper	Record	SUN	Herald
Percentage	50%	30%	20%

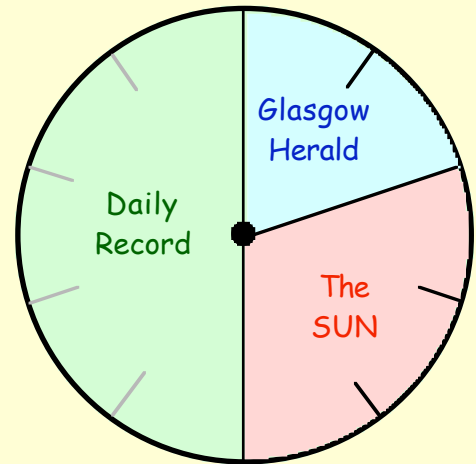

Exercise 4

1. The pie chart shows the results of a class analysis into hair colour.

What percentage of the class had :-

- a dark brown b light brown
c blonde d red
e black hair ?

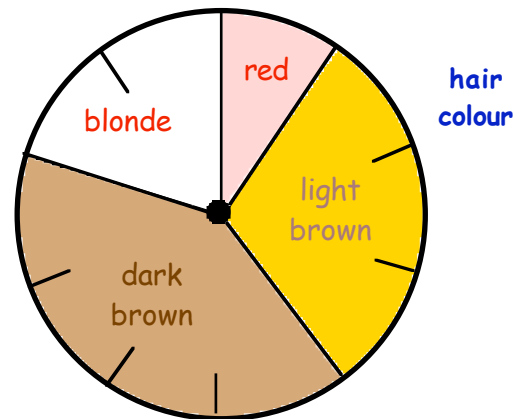

2. This pie chart was drawn up after a survey on "favourite flavours of ice-cream".

- a What percentage does each sector represent ?
b What flavour of ice-cream is most popular ?
c What percentage of the people preferred
(i) strawberry (ii) vanilla
(iii) lime (iv) chocolate ?
d If 400 people were surveyed, how many :-
(i) preferred strawberry ice-cream ?
(ii) preferred vanilla ice-cream ?

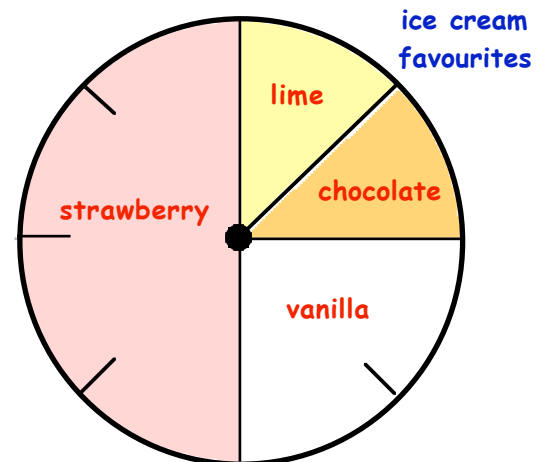

3. This pie chart has been divided into 20 parts.

- a What percentage does each small sector stand for this time ?
- b What percentage of those at the party were
 - (i) boys ? (ii) girls ?
- c There were 35 children at the party. How many of them were :-
 - (i) boys ? (ii) girls ?

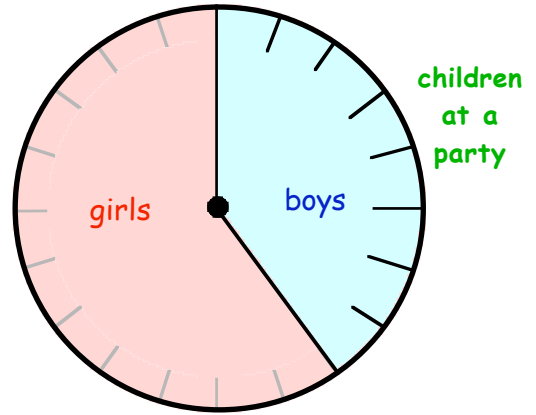

4. This pie chart shows the type of houses the people at a political meeting live in.

- a What percentage of the people live in a
 - (i) bungalow (ii) semi-detached villa
 - (iii) flat (iv) detached villa ?
- b There are 300 people at the meeting. How many of the 300 live in a
 - (i) flat ? (ii) semi-detached villa ?

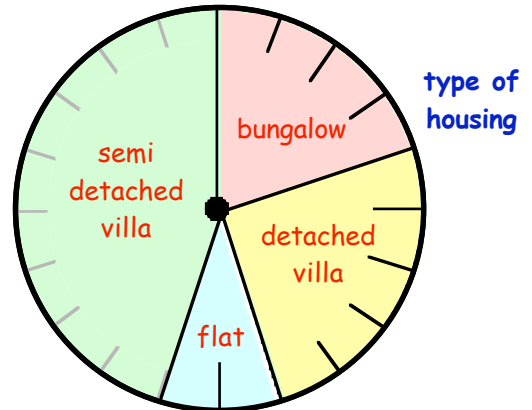

- 5. a How many pieces has this pie chart been divided into ?
- b What percentage does each sector represent ?
- c At lunchtime, what percentage of first year
 - (i) go to the shops (ii) go home
 - (iii) take a packed lunch (iv) take school dinner ?
- d There are 160 pupils in First Year. How many of the 160
 - (i) take packed lunches (ii) take school dinners ?

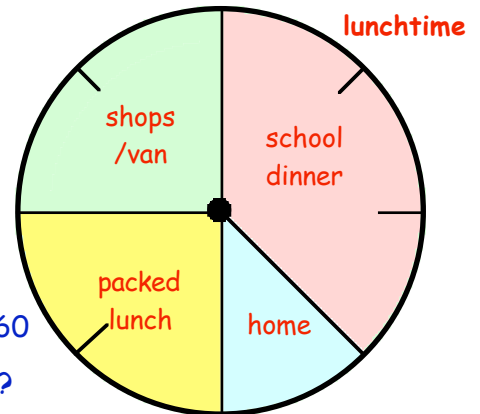

6. **Faults in Cars**

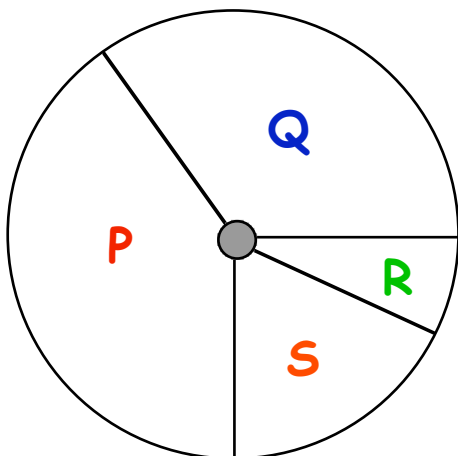

During a police traffic survey, the number of faults which each vehicle had was recorded :-
 43% had baldy tyres, 30% had only 1 brake light working, 9% had broken exhaust pipes and the rest had no road tax disc.

- a Say which sector represents which category.
- b 500 cars were stopped by the police. How many had
 - (i) a baldy tyre ?
 - (ii) no road tax disc ?
- c If one car was to be chosen at random, what would be the most likely fault that it would have ?

7. Rannoch High School's population is given below (as percentages of the whole school).

S1	-	20%
S2	-	25%
S3	-	35%
S4	-	15%
S5/6	-	5%

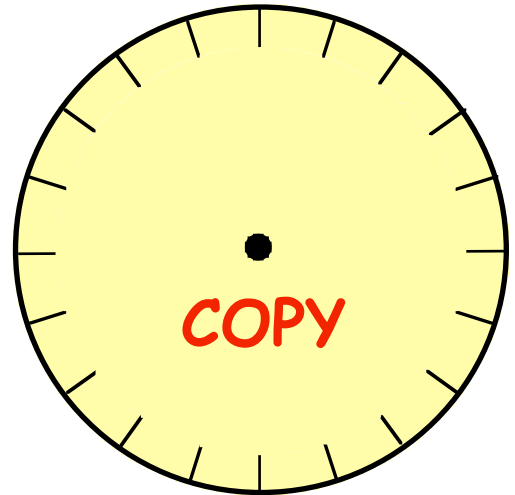

- a Copy or trace the blank pie chart.
- b Complete the pie chart to represent the above information about the school, population clearly labelling each sector.

8. On a family Sunday School trip, it was discovered that of those present,

- 35% of them were boys
- 40% were girls
- 15% were women.

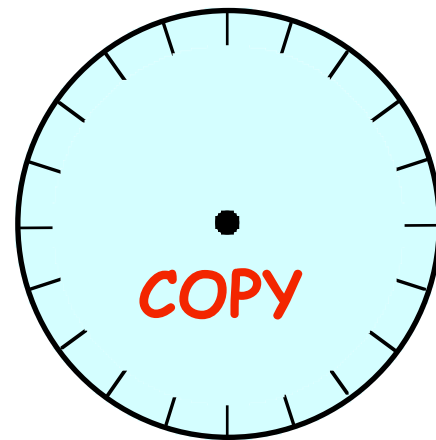

- a What percentage of those present were men?
- b Copy (or trace) the blank pie chart, and complete it showing the above information.

9. Pupils going into third year at St John's School were only allowed to choose one science subject.

- 40% chose Physics
- 30% chose Chemistry
- of the others, half chose Biology and half chose General Science.

- a What percentage chose Biology?
- b Draw a neat pie chart to show how the pupils chose their science subject.

10. Of the 200 men working for Davis Construction

- 100 of them were brickies,
- 50 of them were joiners,
- 30 of them were plumbers
- the rest were labourers

- a Write down what percentage of the workers were brickies, joiners, plumbers and labourers.
- b Draw a neat pie chart to show this information.



Topic in a Nutshell

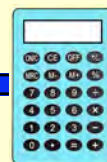

1. Calculate the **mean** of :-

- a 3, 7, 4, 9, 12.
- b £3.20, £4.10, £6.10, £8.40, £1.60, £3.90, £7.10, £5.40, £8.80, £5.40.

2. In a gymnastic competition, the marks given to a young gymnast by the eight judges were :-

8.2, 7.8, 8.4, 7.8, 8.6, 8, 10, 7.6.



- a Calculate the **mean** mark.
- b How many marks below this mean was the lowest mark ?
- c One of the judges turned out to be an uncle of the young gymnast. Can you say which judge it was most likely to be ?

3. The **mean** number of houses in 3 streets in a new housing estate is 20. Arran Road has 25 houses and Bute Place has 18.

How many houses must there be in Cumbrae Avenue ?

4. The scores, out of 20, in a French Assessment were recorded.

6	4	18	15	19	20	15	9	17
14	15	20	14	20	15	12	8	10
9	17	15	6	7	6	11	15	12

- a Organise the data into a **frequency table**.
- b How many pupils sat the assessment ?
- c How many pupils got full marks ?

Score	Tally	Frequency

5. The heartbeats of two football supporters were monitored during a cup final. The results are shown in the line graph below.

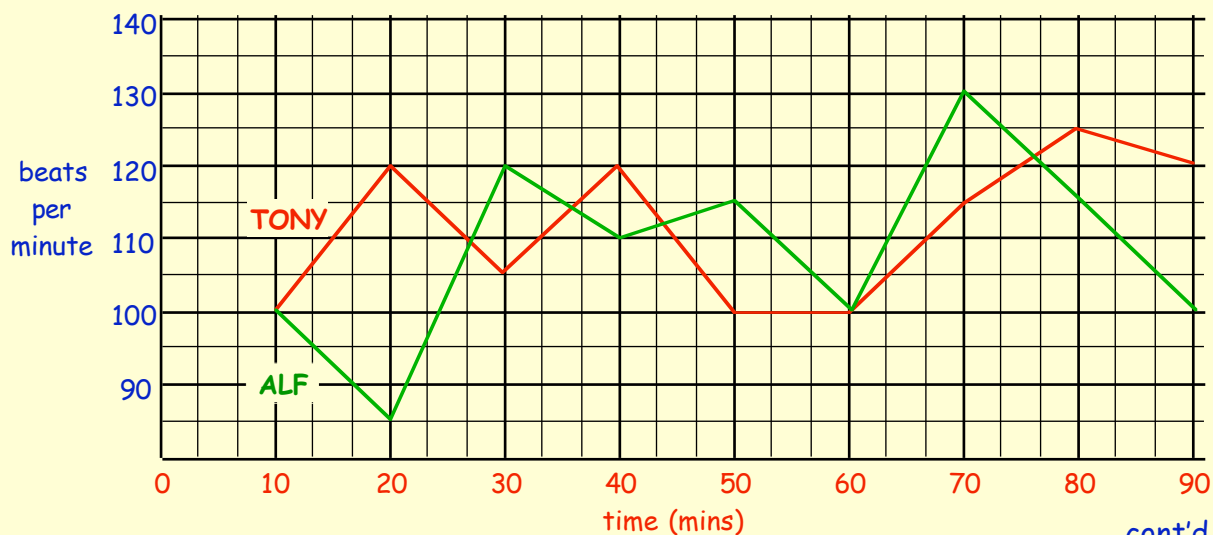

cont'd..

5. a On how many occasions was Alf's heartbeat :-

- (i) above Tony's ?
- (ii) the same as Tony's ?
- (iii) below Tony's ?



- b In the 40th minute, how many **more** beats than Alf was Tony's heart beating ?
- c In the 20th minute a goal was scored. Who's team scored - Alf's or Tony's ?
- d At the end of the game, one of the two supporters was bitterly disappointed at the result. Who's team lost - Alf's or Tony's ?

6. The pie chart shown has been divided into 20 parts.

It records the newspapers which a group of people read.

a What **percentage** of those asked read :-

- (i) the Express ?
- (ii) the Times ?

b If the group surveyed consisted of 400 people, **how many** read :-

- (i) the Sun ?
- (ii) the Record ?

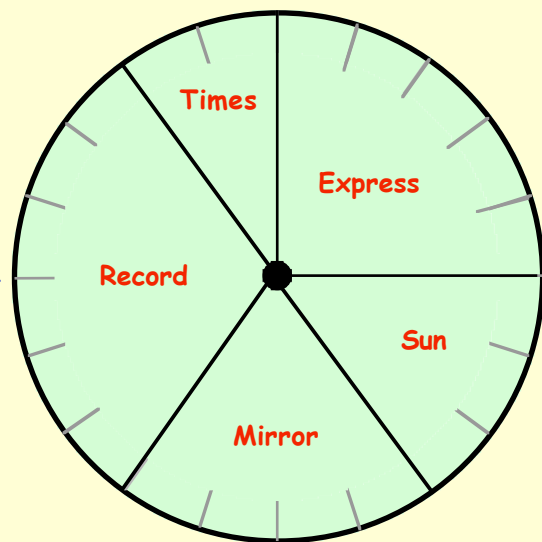

7.

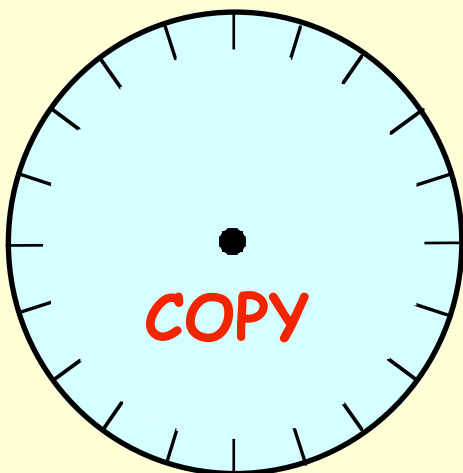

In a survey carried out in a baker's shop about "**favourite type of scones**", it was found that :-

25% of those asked preferred "**Plain**".

50% of those asked preferred "**Fruit**".

$12\frac{1}{2}\%$ of those asked preferred "**Treacle**".

$12\frac{1}{2}\%$ of those asked preferred "**Soda**".

Copy or trace the blank pie chart and show the results of the above survey.

Chapter 10

Length & Area

Units of Length

millimetre
centimetre
metre
kilometre

There are 4 units of length used in the **METRIC** system.

The **METRE**

This is the standard unit of length - it is about the distance from your nose to the end of your out-stretched arm.

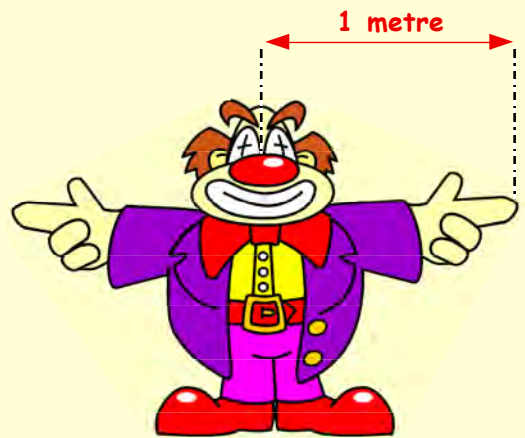

The **centimetre**

This is $\frac{1}{100}$ of a metre. About the width of you pinky nail.

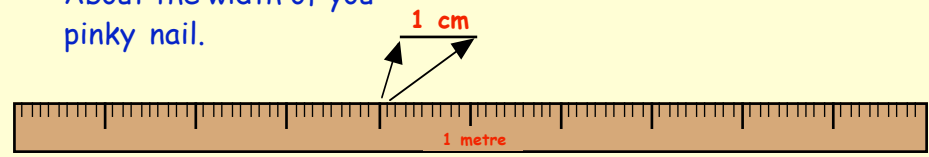

The **millimetre**

This is $\frac{1}{10}$ of a centimetre. About the width of a sewing needle.



The **kilometre**

This is equal to 1000 metres.

To change :-

kilometres → metres ($\times 1000$)	metres → kilometres ($\div 1000$)
metres → centimetres ($\times 100$)	centimetres → metres ($\div 100$)
centimetres → millimetres ($\times 10$)	millimetres → centimetres ($\div 10$)

Exercise 1

1. How many :-

- a metres in 1 kilometre ?
- b centimetres in 1 metre ?
- c millimetres in 1 centimetre ?
- d millimetres in 1 metre ?
- e centimetres in 1 kilometre ?
- f millimetres in 1 kilometre ?



2. Change :-

- a 3 metres to centimetres
- b 7 centimetres to millimetres.
- c 2 kilometres to metres
- d one and a half metres to centimetres.

3. Change the following to **centimetres** :-

- | | | | | | | | |
|---|-----------------|---|--------|---|-----------------|---|-----------------|
| a | 2 m | b | 7 m | c | $\frac{1}{2}$ m | d | $\frac{1}{4}$ m |
| e | $\frac{3}{4}$ m | f | 3.5 m | g | 2.7 m | h | 0.8 m |
| i | 1.46 m | j | 6.53 m | k | 0.89 m | l | 0.06 m |

4. Change the following to **metres** :-

- | | | | | | | | |
|---|------------------|---|-------------------|---|----------|---|------------------|
| a | 1 km | b | 4 km | c | 15 km | d | $\frac{1}{2}$ km |
| e | $\frac{1}{4}$ km | f | $\frac{1}{10}$ km | g | 5.6 km | h | 7.3 km |
| i | 0.9 km | j | 1.362 km | k | 0.085 km | l | 0.007 km |

5. Change the following to **millimetres** :- (Remember 1 cm = 10 mm).

- | | | | | | | | |
|---|---------|---|------------------|---|-------------------|---|-------------------|
| a | 9 cm | b | $\frac{1}{2}$ cm | c | $3\frac{1}{2}$ cm | d | 9.1 cm |
| e | 16.8 cm | f | 0.4 cm | g | 12.7 cm | h | $\frac{1}{10}$ cm |

The length of this line can be given in three ways :-

4.8 cm or 48 mm or 4 cm 8 mm.

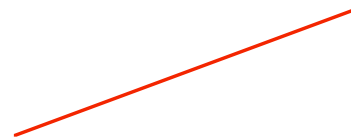

6. Measure each of the following lines and give the length of each in 3 different ways.

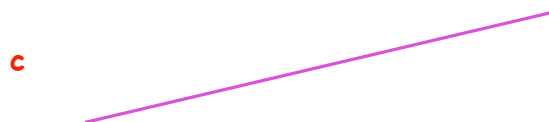

7. Which is longer :-

- | | | | | | |
|---|-----------------------------|---|------------------------------|---|------------------------------|
| a | $\frac{1}{4}$ km or 230 m ? | b | $\frac{1}{2}$ cm or 6 mm ? | c | $1\frac{3}{4}$ m or 180 cm ? |
| d | $\frac{1}{2}$ km or 505 m ? | e | 22 mm or $2\frac{1}{4}$ cm ? | f | 0.8 km or 90 m ? |

Remember :- 230 cm = (230 ÷ 100) = 2.3 m.

8. Change the following to **metres** :-

- | | | | | | | | |
|---|--------|---|--------|---|--------|---|---------|
| a | 400 cm | b | 650 cm | c | 175 cm | d | 1230 cm |
| e | 68 cm | f | 102 cm | g | 4 cm | h | 1000 cm |

9. Change the following to **kilometres** :-

- a 5000 m b 13 000 m c 2500 m d 1600 m
e 2320 m f 800 m g 750 m h 90 m

10. A running track is 400 metres long.

How far, in **kilometres**, will a runner have travelled if he races around the track :-



- a 3 times b 5 times c $12\frac{1}{2}$ times ?

11. A lollipop stick is 7 millimetres wide.

What is the **total** width of a strip of

- a 10 sticks ?
b 20 sticks ?
c 17 sticks ?

(give each of your answers in cm)

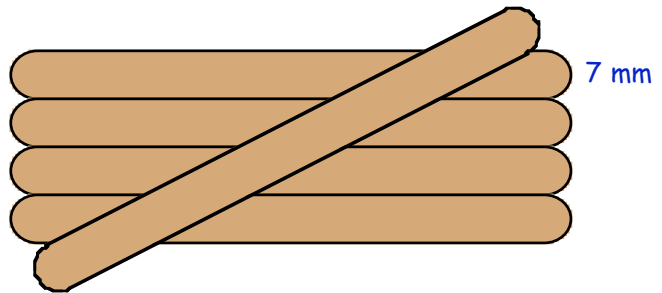

12. I have a piece of rope 2.4 metres long.

From it I cut 3 pieces, one piece 65 cm long, one piece 1.4 m long and a final piece $\frac{1}{4}$ metre long. Calculate the length of rope I have left over.

13. A fence consists of uprights 8.5 cm wide with a gap between each post of 30 cm.

- a Calculate the length of a fence consisting of 7 posts.
(Careful! - give your answer in metres)
b A fence is known to be 3.55 metres long. Calculate how many upright posts it must contain ?

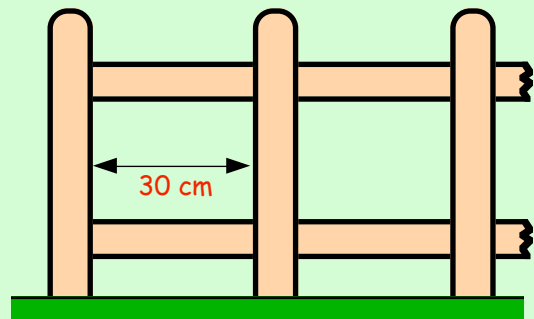

14. Terry the tortoise raced against Henry the hare.

Terry travelled at 45 centimetres per minute.
Henry ran at a rate of 120 metres per minute.
How far ahead of Terry was Henry after :-

- a 1 minute ?
b 2 minutes ?
c 10 minutes ?

(give your answers in metres)



Perimeter

The **perimeter** of a shape is simply :-

"the **total distance** around its outside".

$$\begin{aligned} \text{perimeter} &= (3.5 + 3.1 + 4.2 + 2.8) \text{ cm} \\ &= \mathbf{13.6 \text{ cm}} \end{aligned}$$

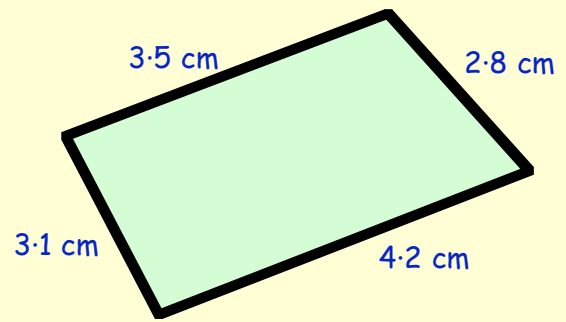

Exercise 2

1. Calculate the **perimeter** of this triangle.
(show your working)

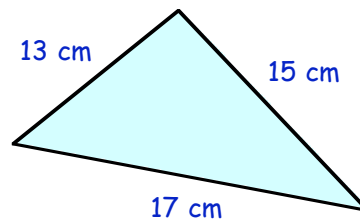

2. Calculate the **perimeter** of each of the following shapes :-

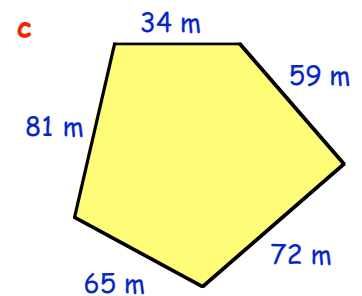
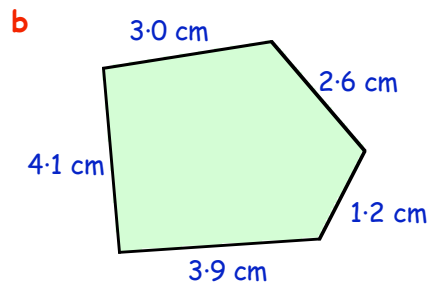
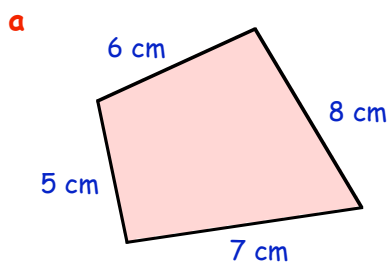

3. Calculate the **perimeter** of this rectangle.
(Note - it is **not** 6.6 cm + 2.7 cm).

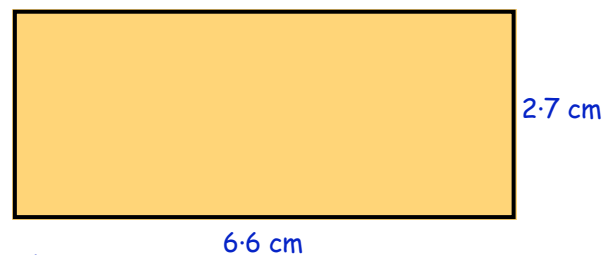

4. Calculate the **perimeter** of each of these rectangles :-

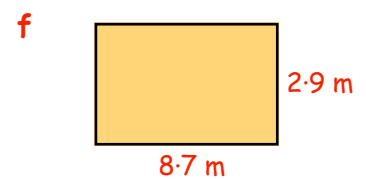
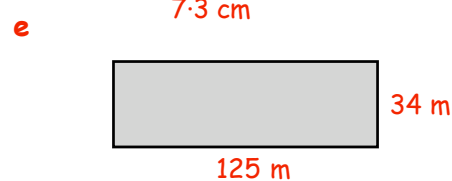
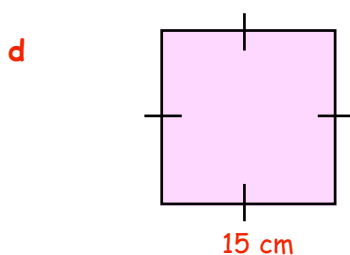
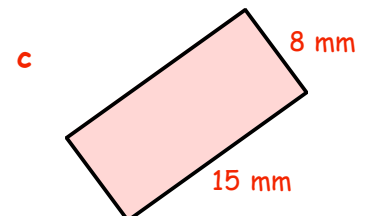
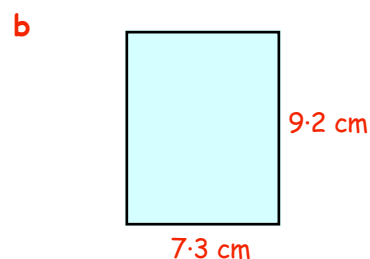
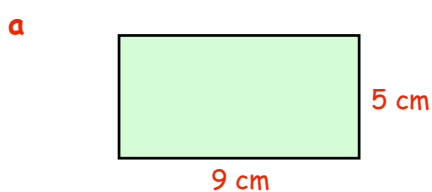

5. This triangle has a **perimeter** of 75 centimetres.
Calculate the length of the third side.

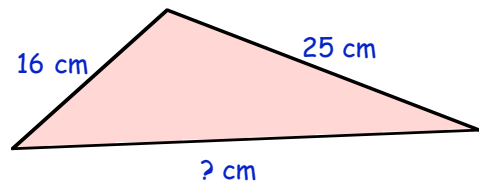

6. Calculate the lengths of the missing sides of the following figures :-

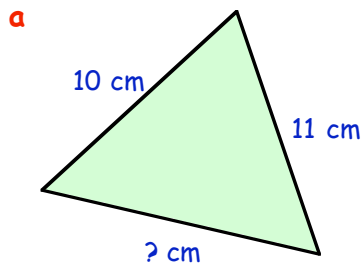

perimeter = 30 cm

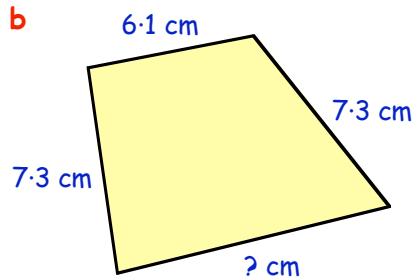

perimeter = 28.9 cm

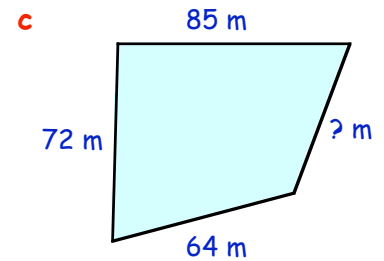

perimeter = 279 m

7. The **perimeter** of this rectangle is 32 cm.
Calculate the missing side of the rectangle.
(Think carefully how to tackle this).

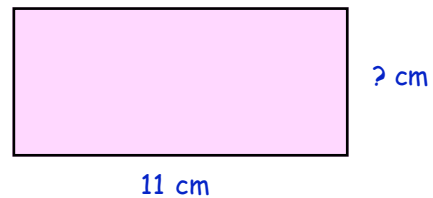

8. Calculate the size of the missing side in each of these rectangles :-

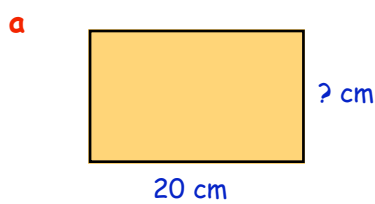

perimeter = 56 cm

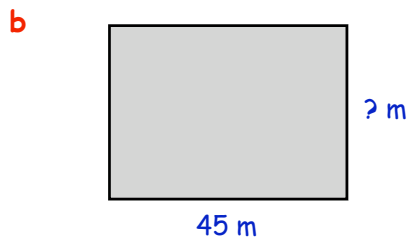

perimeter = 134 m

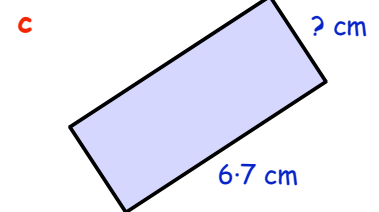

perimeter = 19.6 cm

9. The diagrams show the floor of David's bedroom.

- a Calculate the **perimeter** of the floor.
b How much will it cost to surround it with new skirting board costing £1.20 per metre?
(The door is 0.80 metre wide)

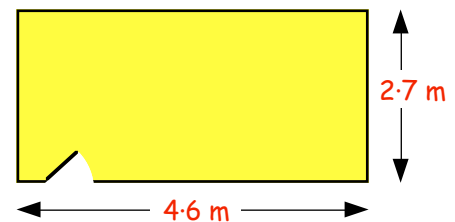

10. Farmer Giles has a rectangular field.
He surrounds it with 3 strands of barbed wire.
The wire costs 30p per metre.
Calculate the total cost of the wire.

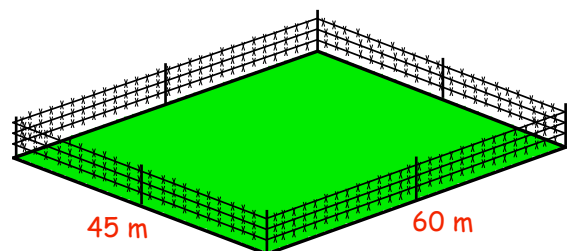

Area

The **AREA** of a shape is simply defined as :-

"the amount of space it takes up"

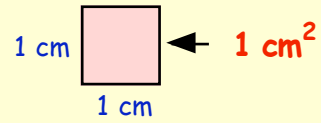

If you think of a box 1 cm by 1 cm, we say it has an area of :-

1 square centimetre

(or 1 cm^2 for short).

(note 1 cm^2 reads as "1 square centimetre")

Exercise 3

1. a How many boxes (1 centimetre by 1 centimetre) are shown here ?



- b Write down its area in square centimetres :- Area = cm^2 .

2. Write down the **areas** (use cm^2) of each of the following shapes :-

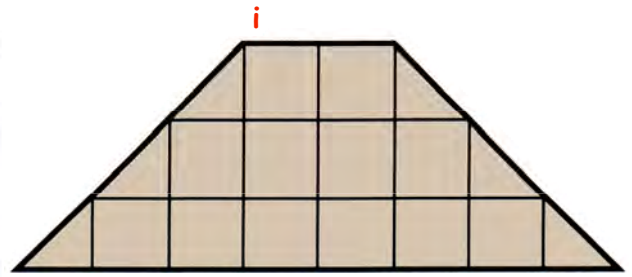
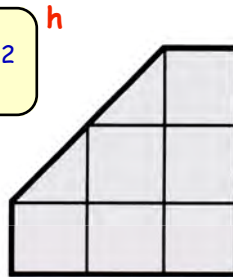
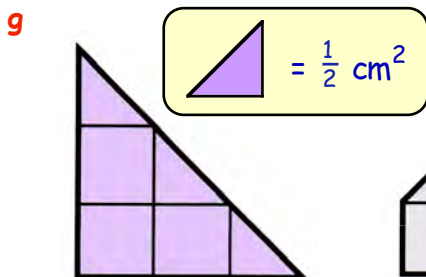
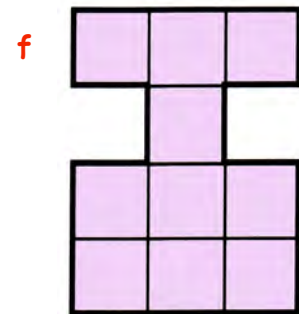
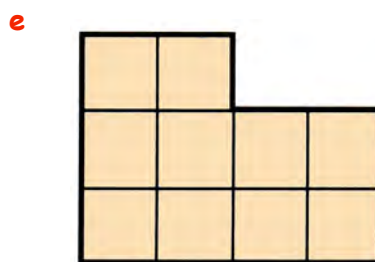
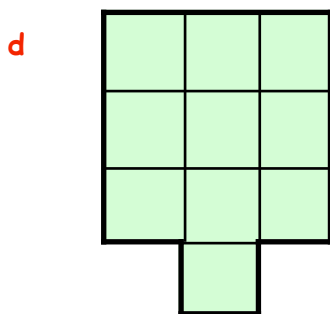
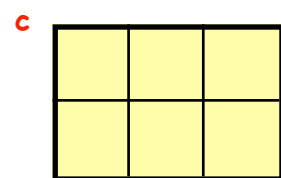
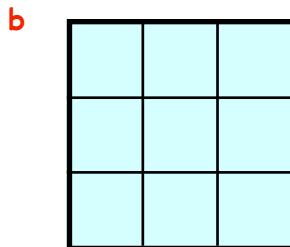
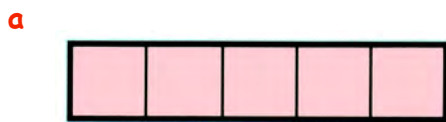

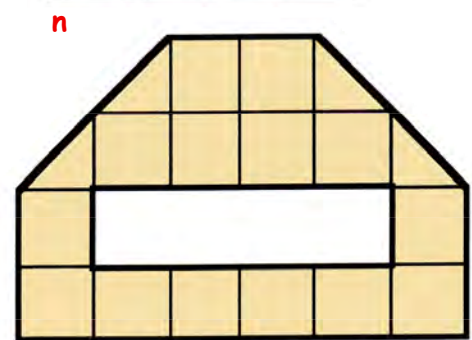
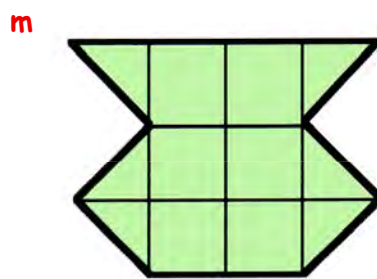
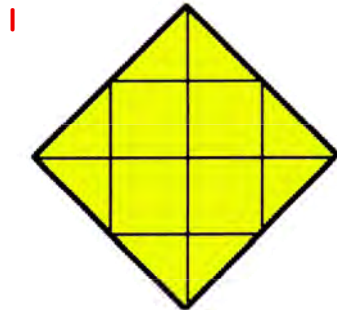
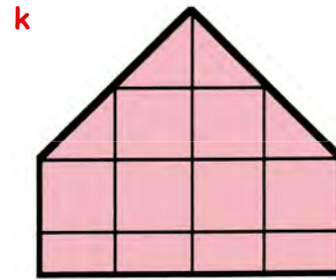
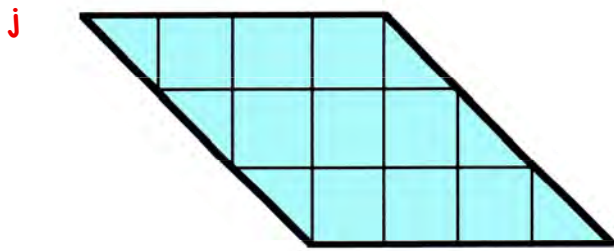

3. Estimate the **areas** of these shapes as follows :-

If **more** than $\frac{1}{2}$ a box is covered \rightarrow **count it as 1 cm²**

If **less** than $\frac{1}{2}$ a box is covered \rightarrow **do not count it at all**

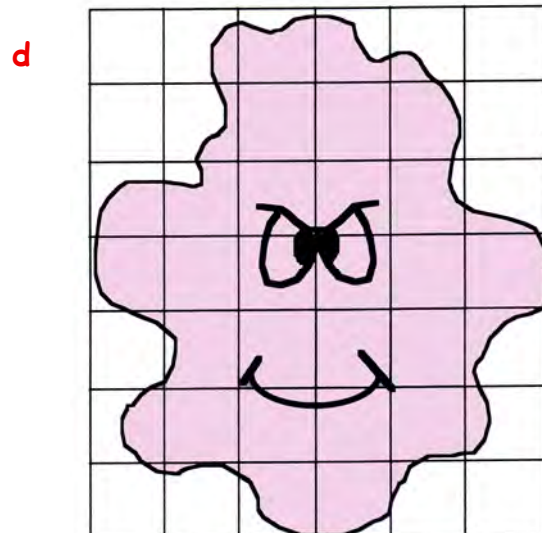
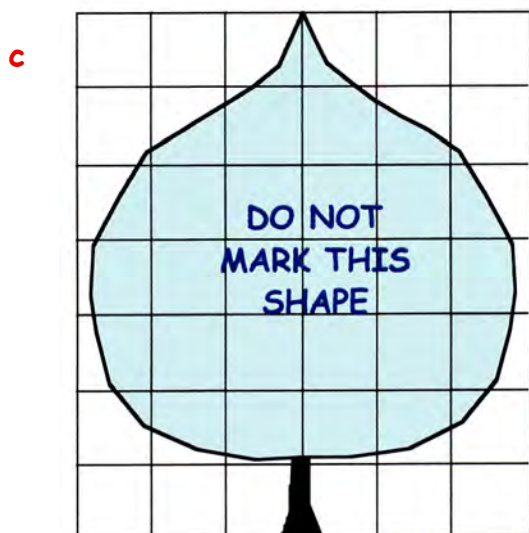
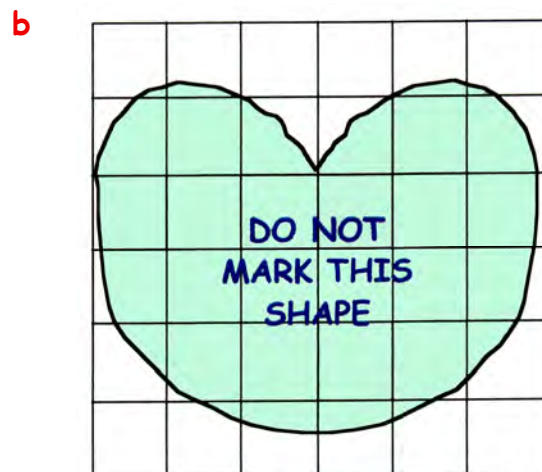
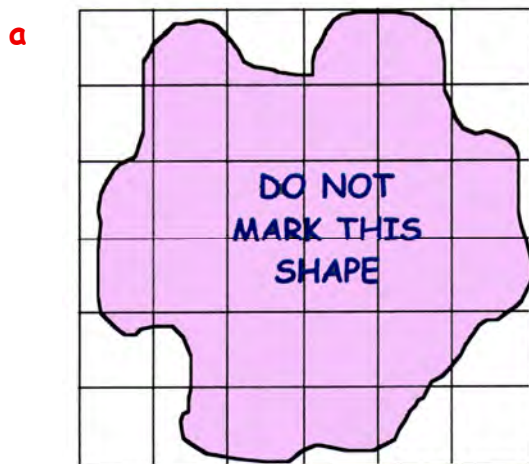

Area of a Rectangle

(a formula)

This rectangle measures 3 centimetres by 4 centimetres.

- a Calculate its **area** (in cm^2) by counting all the boxes.
- b Now write down the answer you get when you multiply its length by its breadth :-
- => $3 \text{ cm} \times 4 \text{ cm}$ (do you get the same answer ?)

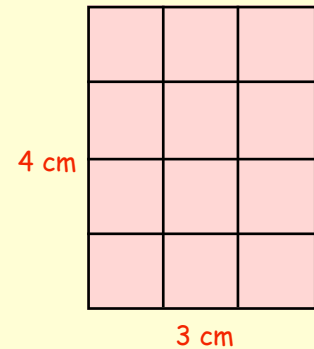

A simple way of calculating the area of a rectangle is as follows :-

Area = length \times breadth

or **$A = L \times B$** for short.

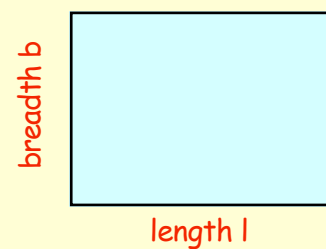

It is **VERY** important that you learn how to use the formula

Area = $L \times B$ when calculating the area of a rectangle.

Exercise 4



no calculator in this exercise until Question 5.

1. a Draw a rectangle 6 centimetres long by 3 centimetres wide.
- b Divide the rectangle neatly into 1 cm square boxes and count the boxes to find the **area** of the rectangle.
- c Use the formula **$A = L \times B$** (width $L = 6$, $B = 3$) to calculate the **area** and check your answer is the same as that obtained in part b.

2. This is a sketch of a rectangle.
- Use the formula

$A = L \times B$
to calculate its area (in cm^2).

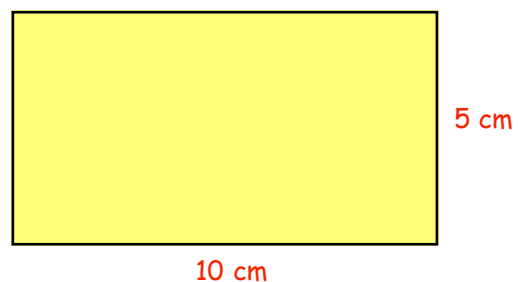

3. Calculate the area of each of the following rectangles.

(in each case, make a small "sketch" of the rectangle,

Write down the rule " $A = L \times B$ " and calculate the area in cm^2).

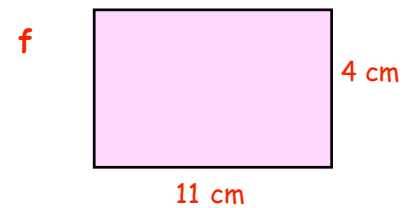
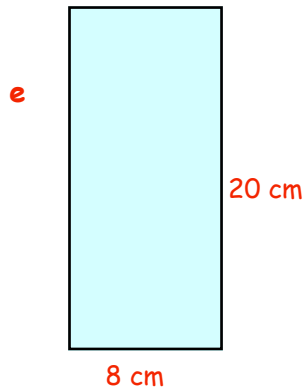
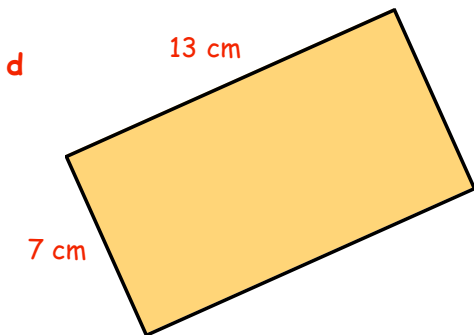
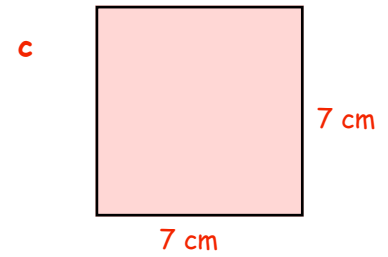
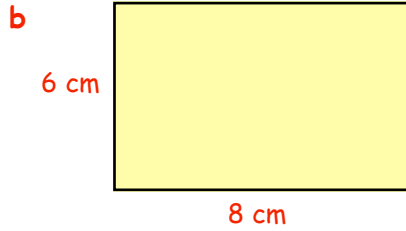
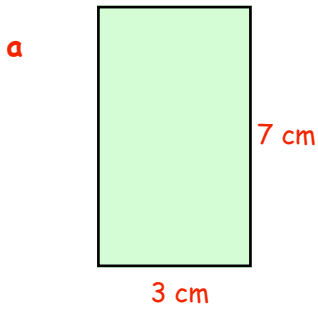

If the length and breadth are in metres,
then the area will be in **square metres**.

The area of this box would be 1 m^2

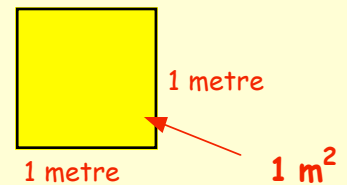

4. Use your formula ($A = L \times B$) to calculate the **areas** of these rooms in square metres :-

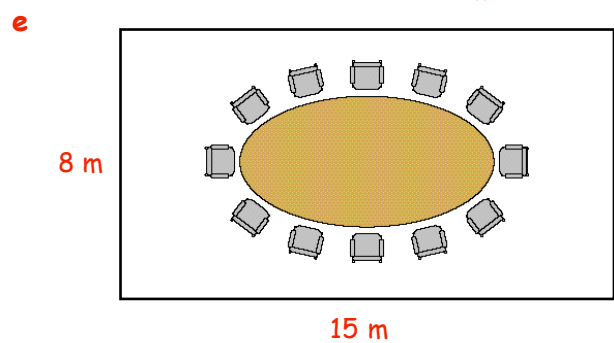
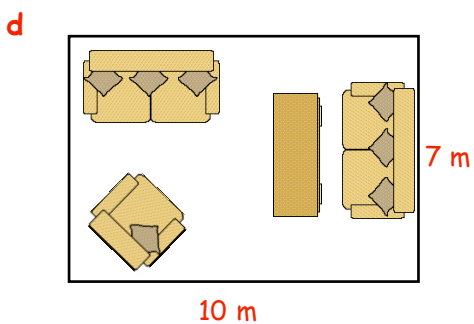
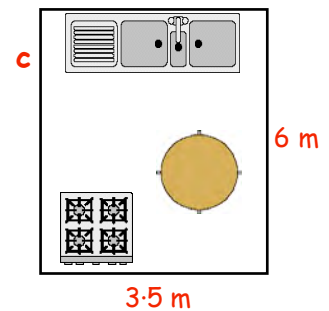
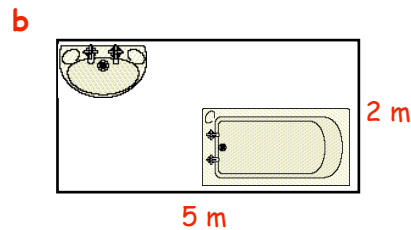
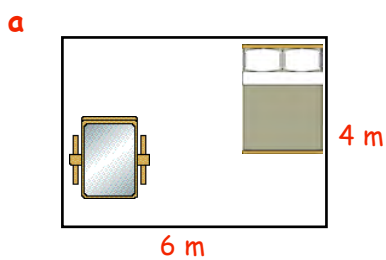

5. Calculate the **areas** of these rectangular fields in m^2 :-
(you may use a calculator here)



a

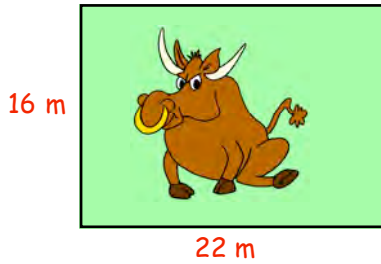

b

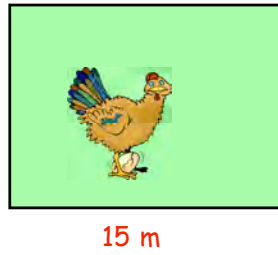

c

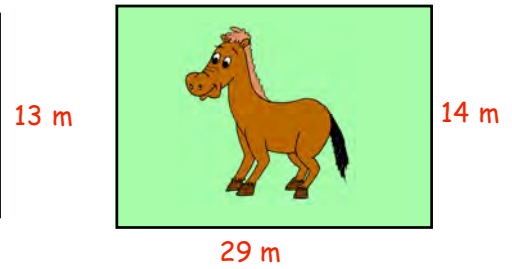

d

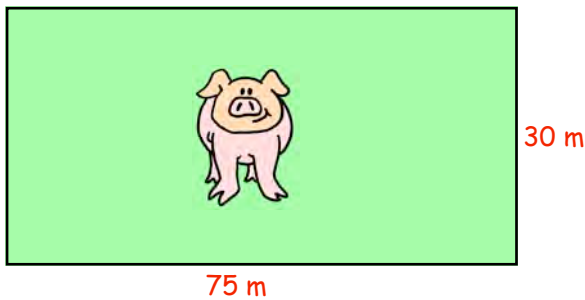

e

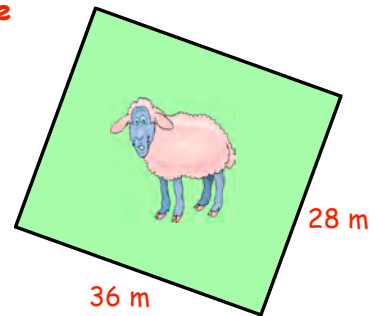

6. Lucy has a rectangular piece of garden.
She wishes to buy turf to create a new lawn.
New turf comes in at £0.85 per m^2 .
Calculate the **total cost** of turf required.

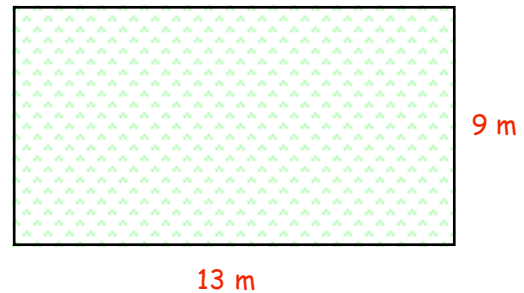

7.

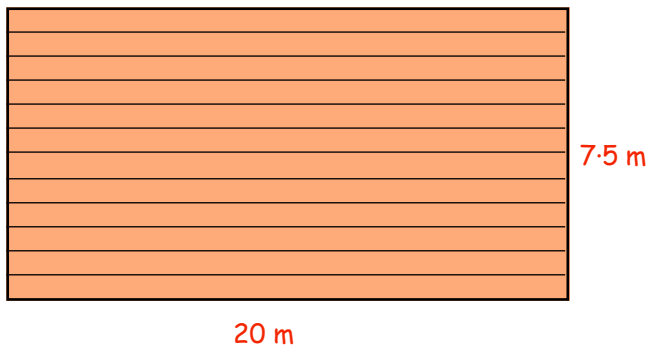

Davie decides to varnish the Scout Hall floor.

- Calculate the **area** of the floor.
- A litre of varnish covers $15 m^2$.
How many tins will be needed for one coat of varnish?
- If each tin costs £4.75, what will it cost to cover the floor with **two** coats of varnish?

- Numerically, which is bigger - the **AREA** of a rectangle measuring 3 cm by 5 cm, or its **PERIMETER**?
- Is this true for any size of rectangle?
Investigate by studying various sizes of rectangles.

Composite Shapes

A **composite** shape is one made up of (or composed of) more than one shape.

The shape shown below consists of 2 rectangles, **P** and **Q**.

$$\text{Area of P} = L \times B = 7 \times 4 = 28 \text{ cm}^2$$

$$\text{Area of Q} = L \times B = 6 \times 9 = 54 \text{ cm}^2$$

$$\text{Total Area} = 28 + 54 = 82 \text{ cm}^2$$

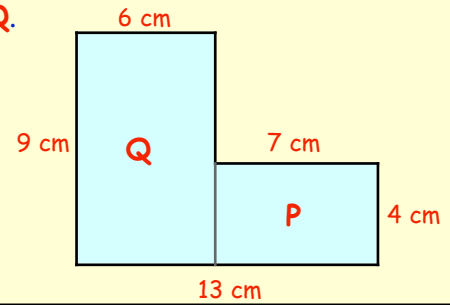

Exercise 5 (Show how you obtain your answer each time !)

1. This L-shaped figure consists of 2 rectangles.

- Calculate the area of rectangle P.
- Calculate the area of rectangle Q.
- Now calculate the **total area** of the shape.

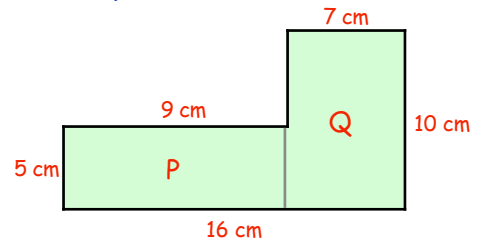

2.

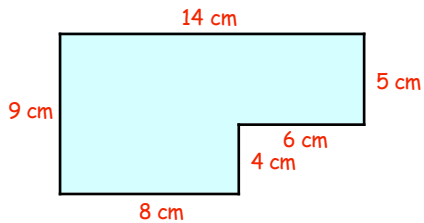

Calculate the **area** of this shape by dividing it into 2 rectangles.
(make a sketch showing how you split it up)

3. Calculate the **total area** of each of the following shapes :- (make sketches each time)

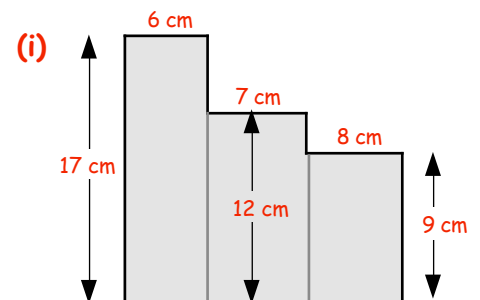
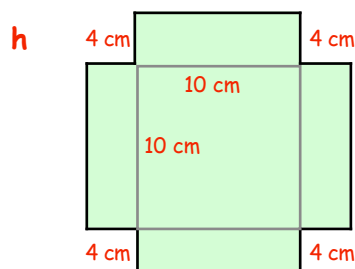
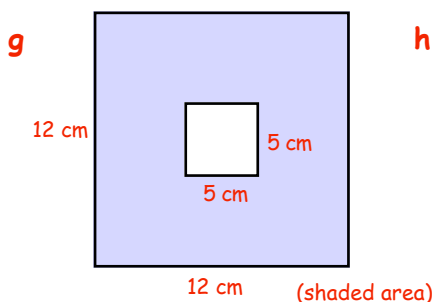
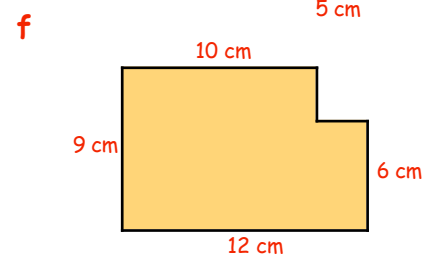
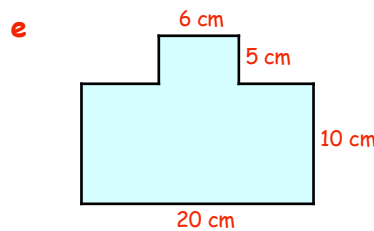
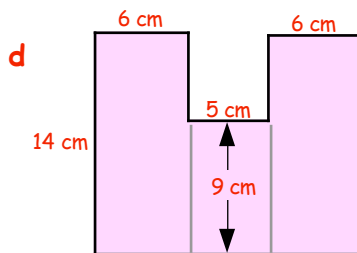
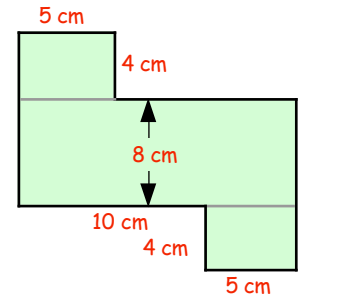
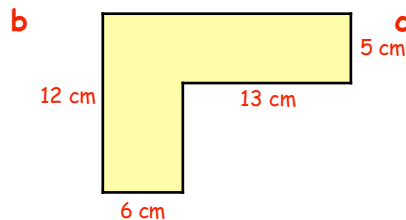
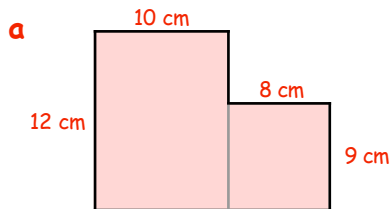

Area of a Right Angled Triangle

To calculate the **area** of a **Right Angled Triangle** :-

Step 1 - Look at the surrounding **rectangle**
 $\Rightarrow \text{Area} = 6 \times 3 = 18 \text{ cm}^2$.

Step 2 - **Halve** your answer \Rightarrow
 $\Rightarrow \text{Area} = \frac{1}{2}$ of 18 = **9 cm²**

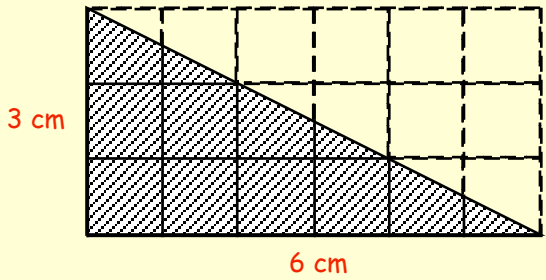

Exercise 6

1.
 - a Make an accurate drawing of this right angled triangle.
 - b Complete the figure by drawing the surrounding rectangle.
 - c Calculate the **area** of the **rectangle**.
 - d Now write down the **area** of the **triangle**.

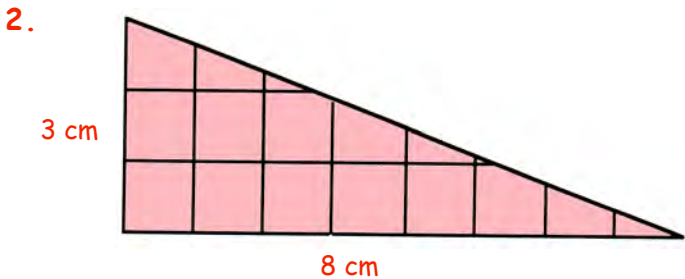
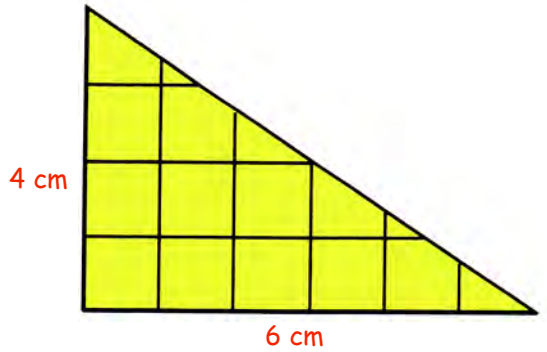

- a Make an accurate drawing of this right angled triangle.
- b Complete the figure by drawing the surrounding rectangle.
- c Calculate the **area** of the **rectangle**.
- d Now write down the **area** of the **triangle**.

3.
 - a Make an accurate drawing of this right angled triangle.
 - b Complete the figure by drawing the surrounding square.
 - c Calculate the **area** of the **square**.
 - d Now write down the **area** of the **triangle**.

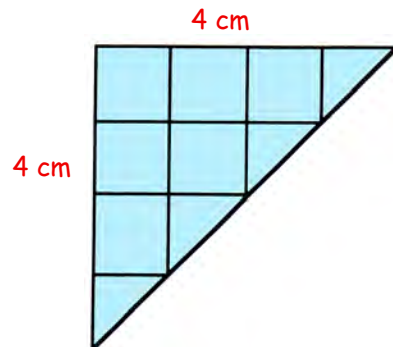

4. Use 1 cm squared paper to draw these right angled triangles :-

- (i) Make an accurate drawing
- (ii) Draw the surrounding rectangle.
- (iii) Find the area of the rectangle.
- (iv) Calculate the **area** of the **triangle**

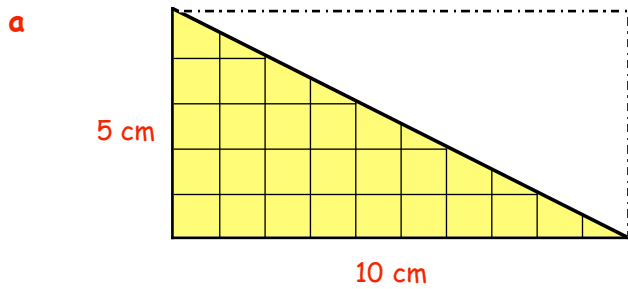

Area (rectangle) = $l \times b = 10 \times 5$
 $= 50 \text{ cm}^2$
 Area (triangle) = $\frac{1}{2}$ of 50 = ? cm^2

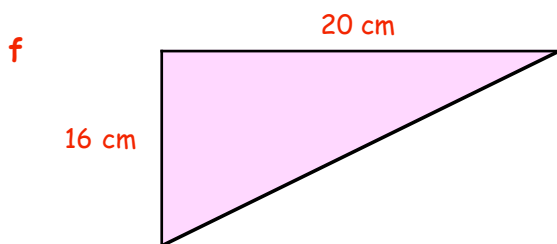
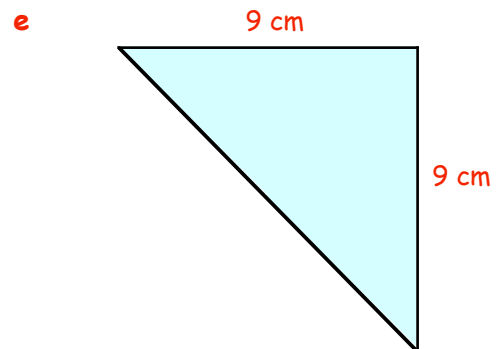
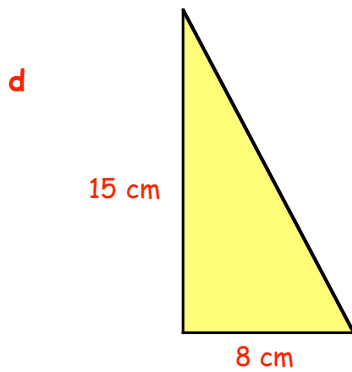
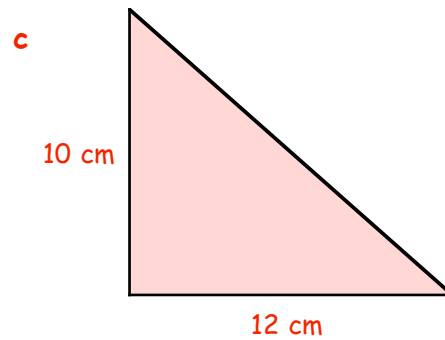
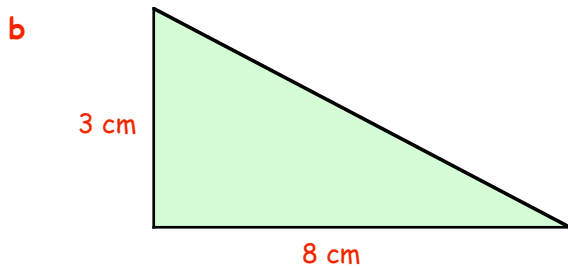

5. Trickier ! This is **not** a right angled triangle

- a Calculate the area of the dotted rectangle.
- b What do you think the area of the shaded triangle will be ?
- c What does this tell you about finding the area of **ANY** triangle ?

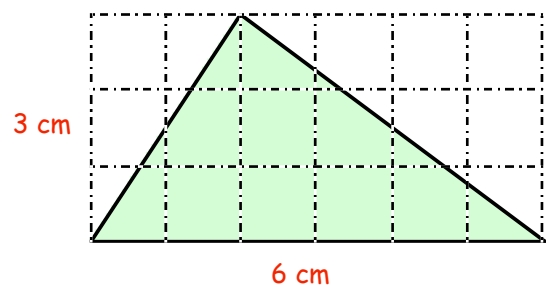

Topic in a Nutshell

1. **Change** :-

a 5.1 metres to cm

b $4\frac{1}{2}$ cm to metres

c 4.7 cm to mm

d 160 cm to m

e 250 m to km

f 30 m to km.

2. I have a stick of rock 8.2 centimetres long.
I bite off 3 pieces, 3.5 cm, 2.4 cm and 9 mm long.



8.2 cm

What length of rock am I now left with ?

3. Calculate the **perimeter** of this rectangle.

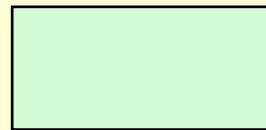

6.7 m

15.8 m

4.

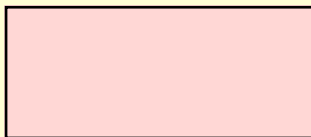

19 cm

y

The perimeter of this rectangle is 52 cm.

Calculate the length of the side marked y (cm).

5. Mr Bright intends to put lighting round the edge of his garden.
Lighting costs £7.50 per metre length to erect.
How much will it cost Mr Bright ?

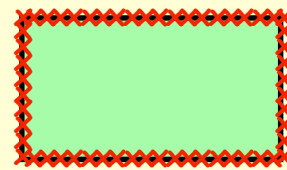

3.5 m

6.5 m

6. Calculate the **area** of :-

a

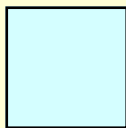

20 m

square

b

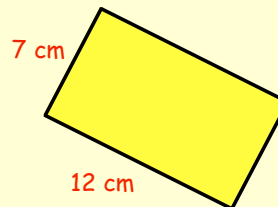

7 cm

12 cm

rectangle

7. Davina wants to re-carpet her bedroom (shown below).

a Calculate the **area** of her room.

b Calculate the cost of carpeting her bedroom
if the carpet costs £18.50 per square metre.

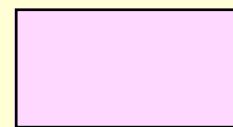

4 m

8.2 m

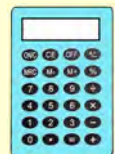

8. Find the **area** of this triangle.

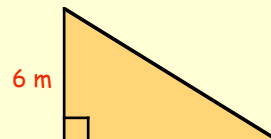

6 m

15 m

9.

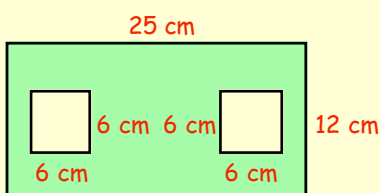

25 cm

12 cm

6 cm 6 cm

6 cm

6 cm

Calculate the green **area** of this shape, made up of a rectangle with two equal squares cut out of it.

Chapter 11



Sequences

When asked to write the next three numbers in this pattern :-

2, 4, 6, 8, 10,

=> you would write 12, 14, 16.

A list of numbers which come in a definite order is called a **Sequence**.

The sequence 2, 4, 6, 8, 10,.... shown above is the sequence of **even** numbers.

Rules :- The **RULE** "add on 2" is used to allow you to move from one even number to the next **consecutive** even number.

In the same way the same **RULE** "add on 2" is used to allow you to move from one **odd** number to the next.

=> the next odd number after 71 is 73.

But...not all rules are simply "add on".

What about the sequence 2, 4, 8, 16, ?

Can you see here the **RULE** is "times by 2" ?

=> the next term in the sequence is 32 !



The rule for the pattern 3, 7, 11, 15, 19, ... is "start at 3 and go up by 4 each time"

Exercise 1

1. Give a possible rule used in these sequences :- (begin with "start at ... and then")

- | | | |
|---|---|-----------------------|
| a 2, 5, 8, 11, 14, | b 7, 13, 19, 25, | c 25, 20, 15, 10, ... |
| d 98, 81, 64, 47, | e 3, 9, 27, 81, | f 1, 6, 36, 216, ... |
| g 200, 100, 50, 25, | h 192, 48, 12, 3, | i 1, 4, 16, 64, ... |
| j $1\frac{1}{2}, 2, 2\frac{1}{2}, 3, \dots$ | k $5\frac{3}{4}, 5\frac{1}{4}, 4\frac{3}{4}, 4\frac{1}{4}, \dots$ | l 1, 2, 4, 8, ... |
| m 200, 100, 0, -100, | n 108, 36, 12, 4, | o 2, 1, 2, 1, ... |

2. Find 3 more numbers for each sequence :-

- | | | |
|-------------------------|------------------------|-------------------------|
| a 7, 9, 11, 13, | b 5, 9, 13, 17, | c 24, 22, 20, |
| d 70, 58, 46, 34, | e 1, 3, 9, | f 2, 4, 8, 16, |
| g 96, 48, 24, | h 1000, 100, 10, | i 1, 6, 11, 16, ... |
| j 2, 3, 5, 8, | k 3, 4, 6, 9, | l 2, 6, 12, 20, 30, ... |

Square Numbers and Triangular Numbers

16 is called a **Square Number**, because 16 dots can be arranged to make a square pattern (4 by 4).

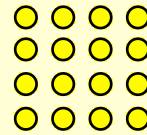

The sequence of **square** numbers is :- 1, 4, 9, 16, 25, with the corresponding patterns below.



Exercise 2

1.
 - a Draw the next **square** dot pattern after 25.
 - b Write down the next **square** number after 25.
 - c Write down the next **square** number after that.
 - d Write down the 10th **square** number.
 - e Write down the 20th **square** number.

When a number is **multiplied by itself** the answer is called a **square number**.

25 is the square of 5. 5×5 can be written as 5^2 . 5^2 is read as "5 squared".

2. Which of the following numbers are square numbers :-
20, 64, 37, 72, 49, 52, 90, 26, 81, 100, 900, 1000 ?

3.
 - a Copy and complete the table showing the first 20 "**perfect squares**" :-

<i>Number</i>	1	2	3	4	5	6	7	8	9	10	11	12	13	14	15	16	17	18	19	20	
<i>Square</i>																					

- b Notice $25 + 144 = 169$. i.e. $5^2 + 12^2 = 13^2$.

Use the table to find more pairs of square numbers which add together to give another square number.

Triangle patterns of dots give what are called the **Triangular Numbers**.

The sequence of **triangular** numbers goes 1, 3, 6, 10, 15, .. with the corresponding patterns :-

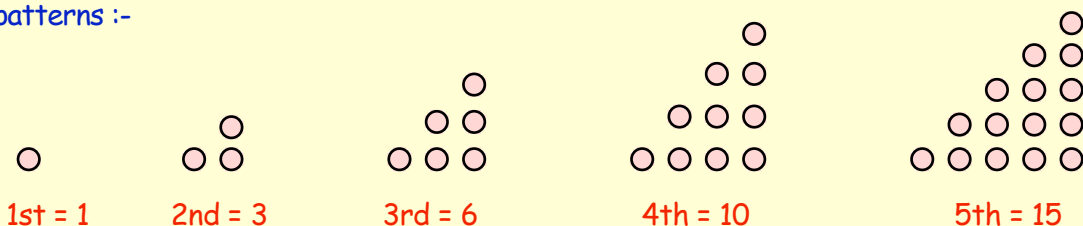

4. a Draw a dot diagram for the next **triangular** number i.e. the 6th.
 b Now write down the 6th **triangular** number.
 c How many dots did you have to add to the 5th triangle to get the 6th ?
 d How many dots will you have to add to the 6th triangle to get the 7th ?
 e Write down the 7th **triangular** number.
 f How many dots would you have to add to the 20th triangle to get the 21st ?
 g The 20th triangular number is 210. What is the 21st **triangular** number ?
 h What is the 22nd **triangular** number ?

5. Because :- $25 = 5 \times 5$, \Rightarrow 5 is called the **square root** of 25.
 $16 = 4 \times 4$ \Rightarrow 4 is called the **square root** of 16

Write down the square root of :-

- a 36 b 100 c 49 d 225 e 441.

6. Instead of saying "the **square root** of $25 = 5$ ", we can write this in a shorter form :-
 \Rightarrow the square root of $25 = 5$ is written as $\sqrt{25} = 5$ (reads as "**square root** of 25").

Find :-

- a $\sqrt{9}$ b $\sqrt{64}$ c $\sqrt{1}$ d $\sqrt{81}$ e $\sqrt{121}$.

7. Copy and extend this pattern for four more rows, then **write down** the 10th row.

$$\begin{aligned} 2^2 - 1^2 &= 4 - 1 = 3 = 2 + 1 \\ 3^2 - 2^2 &= 9 - 4 = 5 = 3 + 2 \\ 4^2 - 3^2 &= 16 - 9 = 7 = 4 + 3 \end{aligned}$$

8. a Add the first two **triangular** numbers. $(1 + 3)$.
 b Add the 2nd and 3rd **triangular** numbers. $(3 + \dots)$.
 c Add the 3rd and 4th **triangular** numbers.
 d Add the 4th and 5th **triangular** numbers.
 e What do you notice about your answers ?
9. a Which two triangular numbers add to give 36 ?
 b **Write down** the value of :-
 (i) 9th triangular number + the 10th triangular number.
 (ii) 19th triangular number + the 20th triangular number.

Simple Linear Patterns

It is sometimes easy to spot a **NUMBER PATTERN** from a diagram or from a table.

Example :- In an Internet Cafe, 3 surfers can sit around each triangular table.

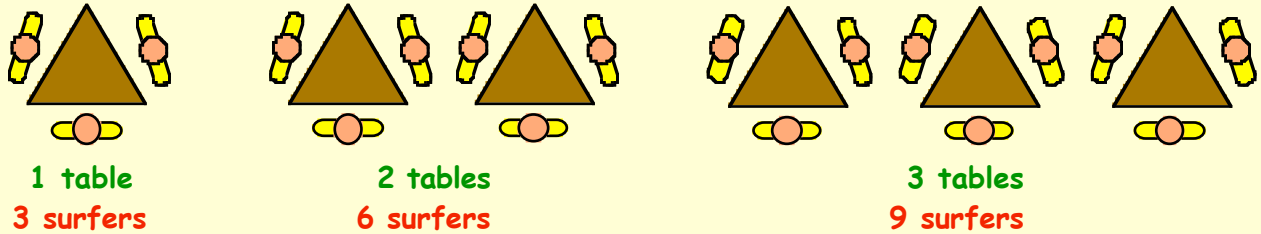

Drawing up a table helps you see the pattern :-

No. of tables (T)	1	2	3	4	5	6
No. of surfers (S)	3	6	9	12	?	?

$\underbrace{\quad\quad\quad}_{+3}$ $\underbrace{\quad\quad\quad}_{+3}$ $\underbrace{\quad\quad\quad}_{+3}$

Can you see that for every new table \Rightarrow the number of surfers **rises by 3**!

\Rightarrow we can write, in words :-

$$\text{no. of surfers} = 3 \times \text{no. of tables}$$

\Rightarrow or in symbol form :- $S = 3 \times T$

Exercise 3

1. A pattern is made using matchsticks :-

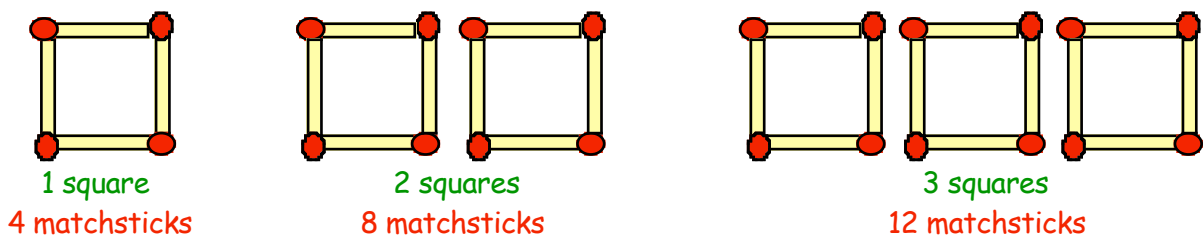

a Draw the next pattern of matchsticks using 4 squares.

b Copy the following table and complete it :-

No. of squares (S)	1	2	3	4	5	6
No. of matches (M)	4	8	?	?	?	?

$\underbrace{\quad\quad\quad}_{?}$ $\underbrace{\quad\quad\quad}_{?}$ $\underbrace{\quad\quad\quad}_{?}$

c For every extra square, how many extra matches are needed ?

cont'd

- d Write down the formula for calculating the number of matches needed assuming you know the number of squares :-

copy this :-

$$\text{number of matches} = ? \times \text{number of squares}$$

- e Now write down the formula using **symbols** $M = ? \times S$.
 f Use your formula to decide how many matches are needed to make 20 squares.

2. Look at the pattern of star-fish and their tentacles :-



1 star-fish
5 tentacles



2 star-fish
? tentacles



3 star-fish
? tentacles

- a Draw the next pattern showing 4 star-fish and their tentacles.
 b Copy the following table and complete it :-

No. of star-fish (S)	1	2	3	4	5	6
No. of tentacles (T)	5	?	?	?	?	?



- c For every extra star-fish, how many extra tentacles are there ?
 d Write down the formula for calculating the number of tentacles there are, assuming you know the number of star-fish :-

copy this :-

$$\text{number of tentacles} = ? \times \text{number of star-fish}$$

- e Now write down the formula using **symbols** $T = ? \times ?$.
 f Use your formula to decide how many tentacles there are if you have 50 star-fish.

- 3.



Price £6



Price £12



Price £...

- a Copy and complete this table, showing the cost of buying a few books .

No. of books (B)	1	2	3	4	5	6
Cost in pounds (C)	6	?	?	?	?	?

- b Copy and complete :- "the total cost of books = ? x the number of books".
 c Write the formula using symbols connecting C and B .
 d Use this "rule" to find the cost of 15 books.

4. A baker slices each half-orange into 8 pieces before liquidising :-

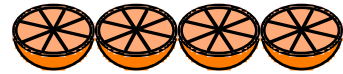
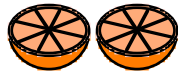

1 half-orange
8 pieces

2 half-oranges
? pieces

3 half-oranges
? pieces

4 half-oranges
? pieces

a Copy and complete this table listing the number of pieces cut from half-oranges.

No. of half-oranges (H)	1	2	3	4	5	6
No. Pieces (P)	8	?	?	?	?	?



- b Copy and complete :- "number of pieces = ? \times the number of half-oranges".
- c Write the formula using symbols connecting P and H .
- d Use this formula to find how many pieces the baker gets from 40 half-oranges.

5. a Copy and complete this table which shows the number of minutes it takes Mr Jones to walk various distances :-

No. of miles (M)	1	2	3	4	5
Time taken (in minutes) (T)	15	30	?	?	?



- b How many extra minutes does it take for each extra mile ?
- c Write a formula connecting the time and the number of miles $\Rightarrow T = ? \times ?$
- d Use your formula to find **how many hours** it would take Mr Jones to travel 12 miles.

6. The "Freebie" newspaper is put through the letterbox every Friday. The table indicates the total number of pages for such a newspaper :-

No. of newspapers (N)	3	4	5	6	7	8
No. of pages (P)	27	36	45	54	?	?



- a If 3 newspapers have 27 pages, how many pages are there in 1 newspaper ?
- b Write a formula connecting the number of pages and the number of newspapers :-
($\Rightarrow P = ? \times ?$)
- c Use your formula to decide how many pages there are in 50 newspapers.



7. For each of these tables, determine a formula or rule connecting the two letters :-

a

No. of trays (T)	1	2	3	4	5	6
No. of plants (P)	50	100	150	?	?	?

$P = ? \times T$

b

No. boxes (B)	1	2	3	4	5	6
No. golf balls (G)	12	24	36	?	?	?

$G = ? \times B$

c

No. of cans (C)	1	2	3	4	5	6
No. worms (W)	110	220	330	?	?	?

$W = ? \times ?$

d

No. of minutes (M)	1	2	3	4	5	6
No. of seconds (S)	60	120	?	?	?	?

$S = ? \times ?$

e

No. of bottles (B)	2	3	4	5	6
No. of millilitres (M)	440	660	880	?	?

* careful

$M = ? \times ?$

f

No. of centipedes (C)	3	4	5	6	7
No. legs (L)	300	400	500	?	?

$L = ? \times ?$

g

No. of tyres (T)	2	3	4	5	6
Cost in £'s (C)	19	28.50	38	?	?

$C = ? \times ?$



More Complicated "Linear" Patterns

In all the patterns we have met so far, the numbers on the bottom line of the table were part of the $2 \times$, $3 \times$, $4 \times$, etc. tables and were easily recognisable.

Look at this different type of pattern, showing people sitting around various numbers of tables in a restaurant.

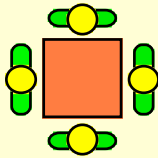

1 table
4 customers

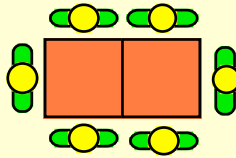

2 tables
6 customers

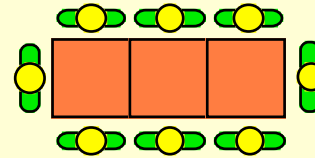

3 tables
8 customers

Drawing up a table helps to see the pattern :-

No. of tables (T)	1	2	3	4	5	6
No. of customers (C)	4	6	8	10	12	14

⏟
2
⏟
2
⏟
2

For every additional table the number of customers **rises by 2** !

step 1 => we can **begin** to write, in symbols :-

$$C = 2 \times T \quad \text{- but this doesn't work !}$$

step 2 => we need a **correction number** to make the pattern work.

look at the ($T=$) 3 and ($C=$) 8 values - can you see that $2 \times 3 \neq 8$

but $2 \times 3 + 2$ gives 8 (check that $2 \times 4 + 2 = 10$, $2 \times 5 + 2 = 12$)

so our real formula is

$C = 2 \times T + 2$

Exercise 4

1. A pattern is made using matchsticks as shown below :-

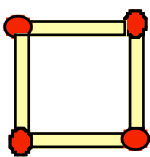

1 square
4 matchsticks

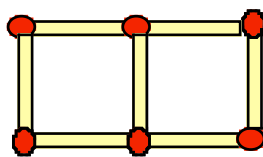

2 squares
7 matchsticks

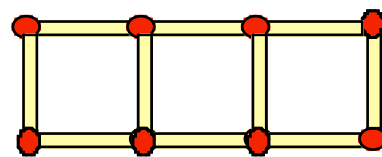

3 squares
10 matchsticks

cont'd

- a Draw neatly the next set of matchsticks patterns with 4 squares.
- b Copy the following table and complete it :-

No. of squares (S)	1	2	3	4	5	6
No. of matches (M)	4	7	?	?	?	?

- c For every extra square, how many **extra** matches are needed ?
- d Write down the formula using **symbols** for calculating the number of matches needed if you know the number of squares :-

copy :-

$$M = ? \times S + ?$$

remember the correction number

- e Use your formula to decide how many matches are needed to make 10 squares.
- f How many matches would be needed for a pattern with 25 squares ?

2. Look at the number of lines needed to make these hexagons :-

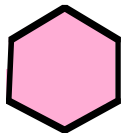

1 hexagon
6 lines

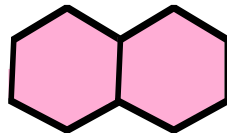

2 hexagons
11 lines

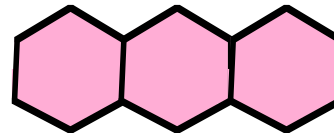

3 hexagons
... lines

- a Draw neatly the next set of lines patterns with 4 hexagons.
- b Copy the following table and complete it :-

No. of hexagons (H)	1	2	3	4	5	6
No. of lines (L)	6	11	...	?	?	?

- c For every extra hexagon, how many extra lines are needed ?
- d Write down the formula using **symbols**. $L = ? \times H + ?$.
- e Use your formula to decide how many lines are needed to place 20 hexagons in a row as in the pattern above.
- f **Hard** - It was found that when a pattern of hexagons was made similar to those above, 46 lines were needed.
How many hexagons must there have been ?

3. This pattern is made up of equilateral triangles:-

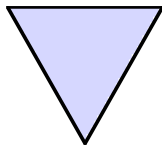

1 triangle
3 matches

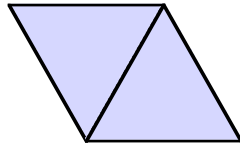

2 triangles
5 matches

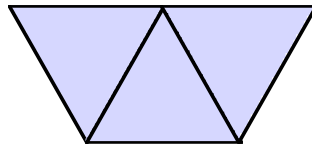

3 triangles
7 matches

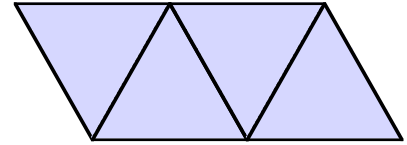

4 triangles
... matches

- a Draw neatly the next pattern with 5 triangles.
b Copy the following table and complete it :-

No. of triangles (T)	1	2	3	4	5	6
No. of lines (L)	3	5	7	...	?	?

?
?
?

- c For every extra triangle, how many extra lines are needed ?
d Write down the formula using **symbols** $L = ? \times T + ?$.
e Use your formula to decide how many lines are needed to place 30 triangles in a row as in the pattern above.
f If 31 lines are used to make one of the above patterns, how many triangles must there have been ?

4. Look at the pattern of fence posts and support panels :-

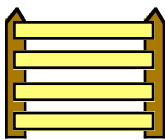

2 posts
4 panels

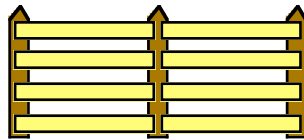

3 posts
8 panels

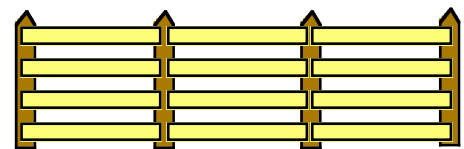

4 posts
12 panels

- a Draw the next pattern of fence posts and support panels.
b Copy the following table and complete it :-

No. of posts (P)	2	3	4	5	6	7
No. of supports (S)	4	8	12	?	?	?

4
?
?

- c For every extra post, how many extra supports are needed ?
d Write down the formula using **symbols** $S = ? \times P - ?$.
e Use your formula to decide how many support panels are needed with 20 posts.

This time the correction number has to be subtracted

5. These "house shapes" are made up of squares and triangles.

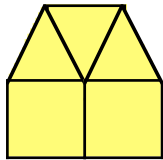

2 squares
3 triangles

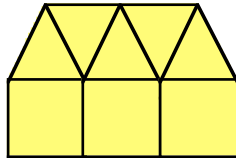

3 squares
5 triangles

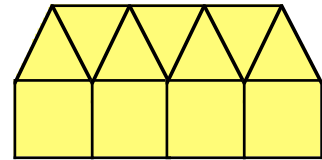

4 squares
7 triangles

- a Draw the next pattern of squares and triangles.
b Copy the following table and complete it :-

No. of squares (S)	2	3	4	5	6	7
No. of triangles (T)	3	5	7	?	?	?

$\underbrace{\quad\quad\quad}_?$
 $\underbrace{\quad\quad\quad}_?$
 $\underbrace{\quad\quad\quad}_?$

- c For every extra square, how many extra triangles are needed ?
d Write down the formula using **symbols** $T = ? \times S - ?$.
e Use your formula to decide how many triangles are needed with 25 squares.

6. This table shows the cost of hiring a carpet cleaner for several days :-

No. of days hired (D)	1	2	3	4	5	6
Cost in £'s (C)	8	11	14	?	?	?



- a How much will it cost to hire the carpet cleaner for
(i) 4 days (ii) 5 days (iii) 6 days ?
b How much **extra** does it cost for each additional day of hire ?
c Write down the formula for determining the cost of hiring the carpet cleaner.

$$C = ? \times D + ?$$

- d How much will it cost to hire the carpet cleaner for 2 weeks ?

7. The number of litres of water required to be added to spoonfuls of weedkiller is shown in the table :-

No. of spoonfuls weedkiller (S)	1	2	3	4	5
Litres of water (W)	1.5	2.0	2.5	3.0	3.5



Find a formula for the number of litres of water required, given the amount of spoonfuls of weedkiller. $W = ? \times S + ?$

8. Shown below are some tables of values connecting pairs of letters.

Write down a formula or rule connecting the second letter in the table to the first letter.

a

Number (N)	1	2	3	4
Price (P)	3	5	7	9

$$P = ? \times N + ?$$

b

No. Trees (T)	1	2	3	4
No. apples (A)	20	30	40	50

$$A = ? \times T + ?$$

c

Police (P)	1	2	3	4
Supporters (S)	50	90	130	170

$$S = ? \times P + ?$$

d

Temp. (T)	1	2	3	4
Volume (V)	15	22	29	36

$$V = ? \times T + ?$$

e

Cakes (C)	1	2	3	4
Time bake (hrs) (T)	0.5	0.75	1.0	1.25

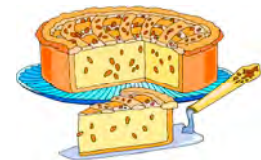

f

Drum beat (D)	10	11	12	13
Time secs (T)	15	17	19	21

g

Sheep dog (D)	1	2	3	4
Sheep (S)	25	65	105	145

9. Mr Jinks is a normal healthy person. He lives with his pet hamsters. Mr Jinks and his hamsters have 62 legs altogether.

How many hamsters does he have ?

10. This model train has an engine and five carriages. The entire train is 63 centimetres long, the engine being of length 8 cm.

How long is each carriage ?



11. Sheila started to cycle from Plockton to Mayberry. She gave up 15 miles after she passed the half-way mark. She was still 30 miles from Mayberry !

How far is it from Plockton to Mayberry ?

12. A rule for finding the number of triangles (T) when if know the number of squares (S) is :-

$$T = 4S - 5.$$

- a If there are 100 squares, how many triangles are there ?
 b If there are 95 triangles, how many squares are there ?

Topic in a Nutshell

1. Give a possible rule used in these sequences :-
(Begin each rule with "start with... then ...")

a 4, 9, 14, 19,

b 40, 32, 24, 16,

c 1000, 200, 40,

d 2, 8, 32, 128,

2. Write down the next **two** numbers in each of the following sequences :-

a 1, 8, 15, 22,,

b 20, 17, 14, 11,,

c 2, 6, 18, 54,,

d 1280, 320, 80,,

e 3, 4, 7, 11, 18,,

f 1, 2, 5, 10, 20,,

3. Write down all the **square** numbers between 30 and 110.

4. Write down the first **seven** triangular numbers.

5.



1 DVD - £3



2 DVDs - £6



3 DVDs - £9

a

No. of DVDs (V)	1	2	3	4	5	6
Cost in £'s to hire (C)	3	6	9			

b Copy and complete :- "the total cost of DVDs = ? x number of DVDs"

c Write a formula linking the DVDs (V) with the cost (C).

d Use this rule to find the cost of hiring 10 DVDs.

6. For each of these tables, determine a formula or rule connecting the two letters :-

a

No. of boxes (B)	1	2	3	4	5	6
No. of tea bags (T)	50	100	150			

$$T = ? \times B$$

b

No. of hours (H)	2	3	4	5	6	7
No. of days (D)	48	72	96			

$$D = ? \times H$$

7. The table below shows the cost of hiring a car in France.

No. of day's hire (D)	1	2	3	4	5	6
Cost in Euros (E)	50	70	90			



- a How much will it cost to hire a car for :-
 (i) 4 days (ii) 5 days (iii) 6 days ?
- b How much **extra** does it cost for each additional day's hire ?
- c Write down the formula for determining the cost of hiring a car in France
 $E = ? \times D + ?$
- d How much, in euros, will it cost to hire a car for 10 days ?

8. Write down a formula connecting the second letter with the first letter in each table :-

a

Number (N)	1	2	3	4
Price (P)	0.5	1	1.5	2

$$P = ? \times N$$

b

No. Trees (T)	1	2	3	4
No. pears(P)	15	25	35	45

$$P = ? \times T + ?$$

c

No. Posts (P)	1	2	3	4
No. Suppts (S)	1	4	7	10

$$S = \dots\dots\dots$$

d

No. Squares (S)	1	2	3	4
No. Triangles(T)	3	7	11	15

$$T = \dots\dots\dots$$

9. Look at this pattern of counters.
 The pattern is not as simple as :-

Counters = ... \times Pattern Number + ...

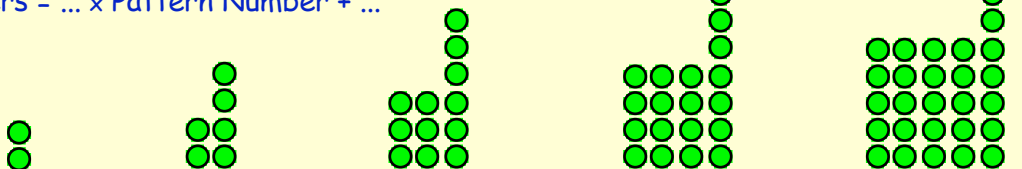

pattern no. 1 pattern no. 2 pattern no. 3 pattern no. 4 pattern no. 5

- a Make up a table to show the number of counters in each pattern.
- b (*difficult*) Try to find a formula to determine the number of counters (C) needed if you know the pattern number (P) :-

$$P = \dots\dots\dots$$

Chapter 12



Types of Angles

By this stage, you should be able to describe the relevant "type" of angle.

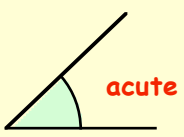

acute

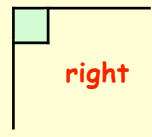

right

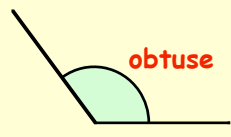

obtuse



straight

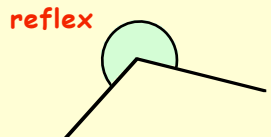

reflex

Exercise 1

1. Use a word from the above list to describe each of the angles shown below :-

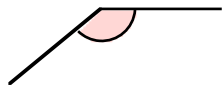
a 

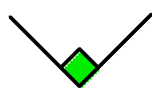
b 

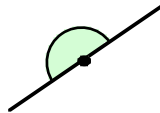
c 

d 

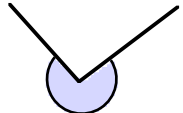
e 

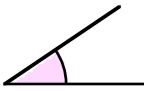
f 

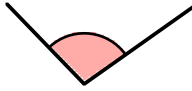
g 

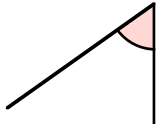
h 

2. What type of angle is marked ● in these triangles :-

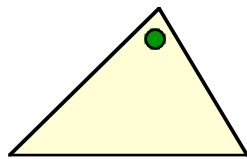
a 

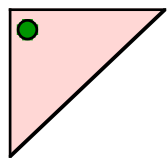
b 

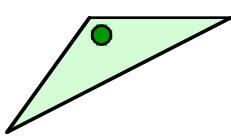
c 

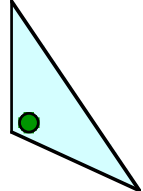
d 

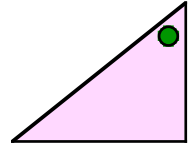
e 

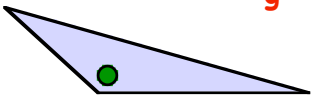
f 

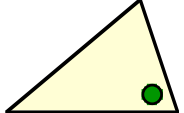
g 

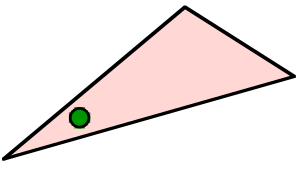
h 

3. Match the type of angle with the given sizes :-

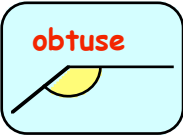

obtuse

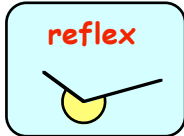

reflex

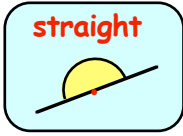

straight

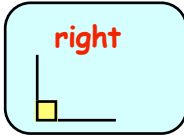

right

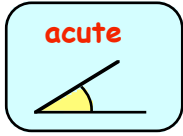

acute

smaller than 90°

between 90° and 180°

exactly 90°

between 180° and 360°

exactly 180°

4. Look at the angle sizes listed below :-

65°, 87°, 115°, 17°, 210°, 180°, 167°, 92°, 90°, 325°, 51°, 177°

- a Which of the angles are obtuse ?
- b Which of the angles are acute ?
- c Which of the angles are straight ?
- d Which of the angles are reflex ?
- e Which of the angles are right ?

Naming Angles

You name an angle each time using **THREE** letters.

$\angle PQR$ is a short way of writing angle PQR.

The **vertex** (corner) letter must be in the middle.

Always use capital letters

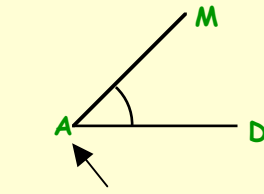

$\angle MAD$ (A is the middle letter)

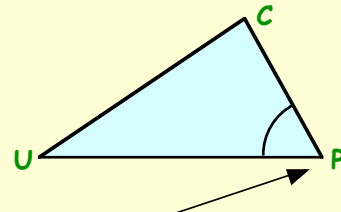

$\angle CPU$ (P is the middle letter)

Exercise 2

1. Use **3 LETTERS** each time to name the following angles :-
(remember to use the " \angle " sign)

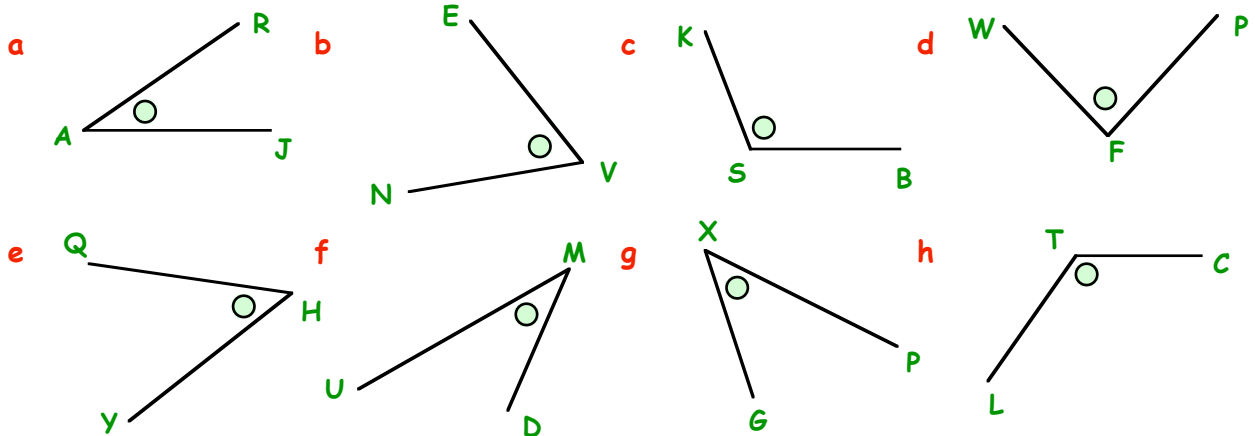

2. Use **THREE** letters to name each angle and say what **TYPE** of angle it is :-

Example - $\angle NTF$ is an **acute** angle.

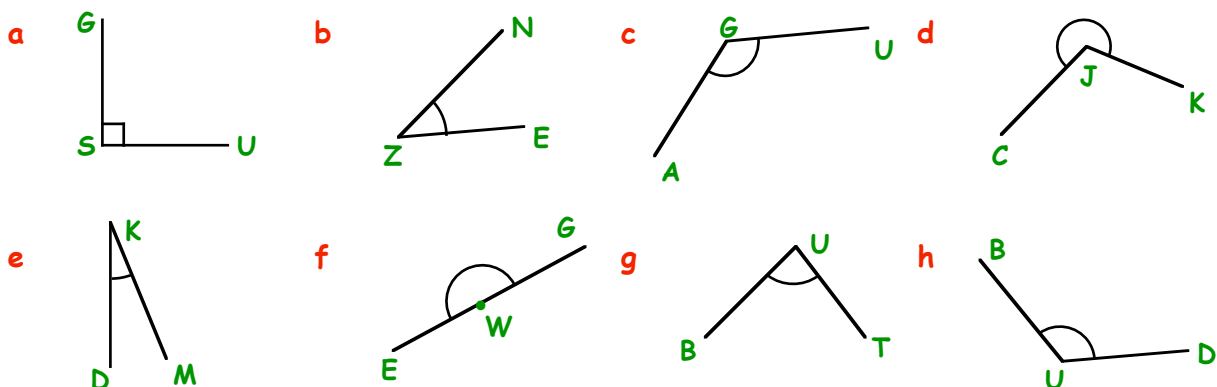
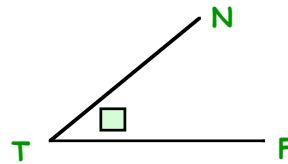

3. In each triangle, there are 3 angles. Be careful how you name them!

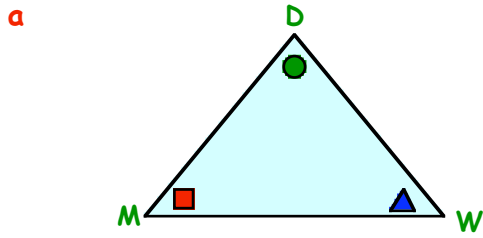
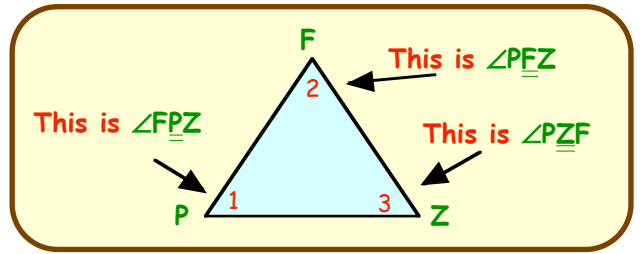

- (i) Name the angle marked \blacksquare .
- (ii) Name the angle marked \bullet .
- (iii) Name the angle marked \blacktriangle .

- b
- (i) Name the angle marked \bullet .
 - (ii) Name the angle marked \times .
 - (iii) Name the angle marked $*$.

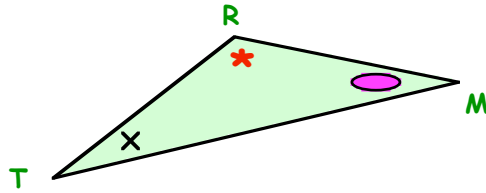

4. Angle (1) is called $\angle \underline{BMG}$. Name the other 4 angles. (Use **THREE** letters each time).

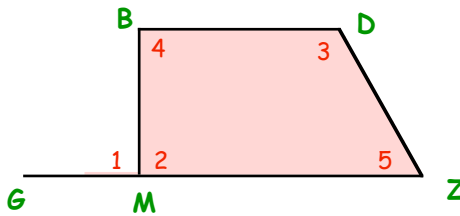

There are 3 angles in this figure. The big one is $\angle \underline{DQX}$.

Name the angles marked :-

- a \blacksquare b $*$

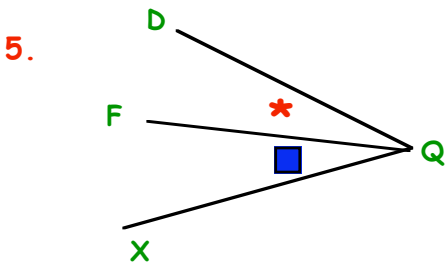

6. There are 8 angles in this figure. Name the angle marked :-

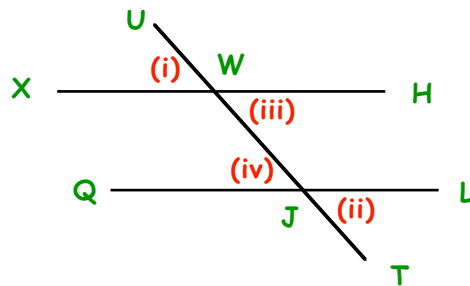

- (i) (ii) (iii) (iv)

7. Neatly draw and label any :-

- a **ACUTE** angle, $\angle \underline{ATZ}$. b **RIGHT** angle, $\angle \underline{FBJ}$. c **OBTUSE** angle, $\angle \underline{RNL}$.

8. a In this figure, there are 3 obtuse angles. One is $\angle \underline{DHP}$. Name the other two. (3 letters).
 b There are 4 right angles. Name them all.
 c How many acute angles are there?
 d Name all the acute angles.

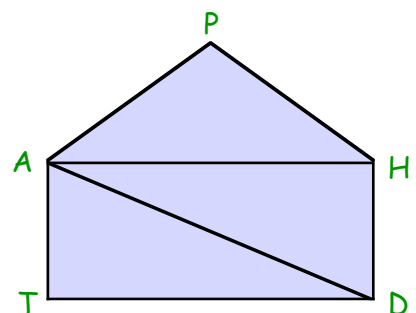

Calculating Missing Angles

Exercise 3

1. Shown are 4 angles which fit exactly around a point.

a What answer will you get if you add all 4 angles ?

$(p + q + r + s = ?)$

b In general, what answer will you ALWAYS get when you add together all the angles round a point ?

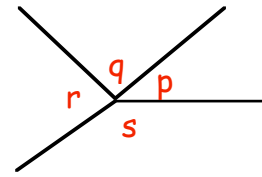

2. a What do you get when you add $130^\circ + 110^\circ$?

b Calculate the size of the 3rd angle (*).

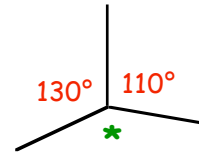

3. Calculate the value of the angles marked \bigcirc .

a

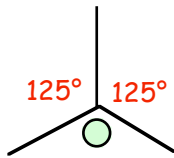

b

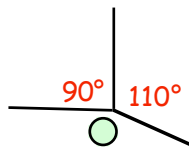

c

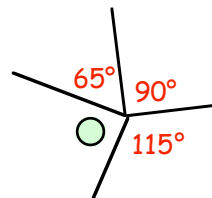

d

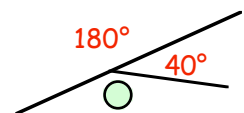

e

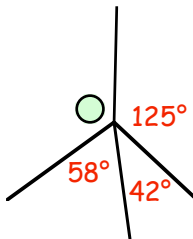

f

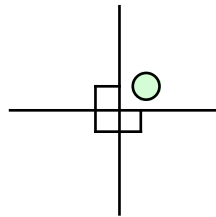

g

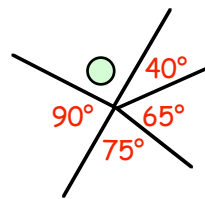

h

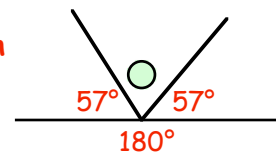

4. A **full** turn is known to be 360° .

a How many degrees in a $\frac{1}{2}$ turn ?

b What is the size of angle PQR, in degrees ?



5. The 2 angles shown make up a straight line.

What must the value of $(a + b)$ be ?

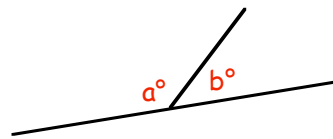

6. In this question, one of the angles is 150° .

Calculate the size of the other angle (\bigcirc).

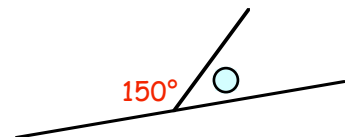

7.

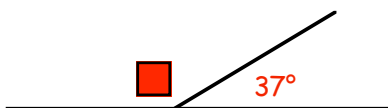

Calculate the size of the angle marked \blacksquare .

We have a special name for a pair of angles that add to 180°

We call them **SUPPLEMENTARY** angles. The supplement of 50° is 130° ($50^\circ + 130^\circ = 180^\circ$)

8. a What is the supplement of (i) 80° (ii) 115° (iii) 170° (iv) 1° ?

b There is only one angle that is its own supplement. What size is the angle ?

9. Calculate the size of the angles marked **a, b, c, ...**

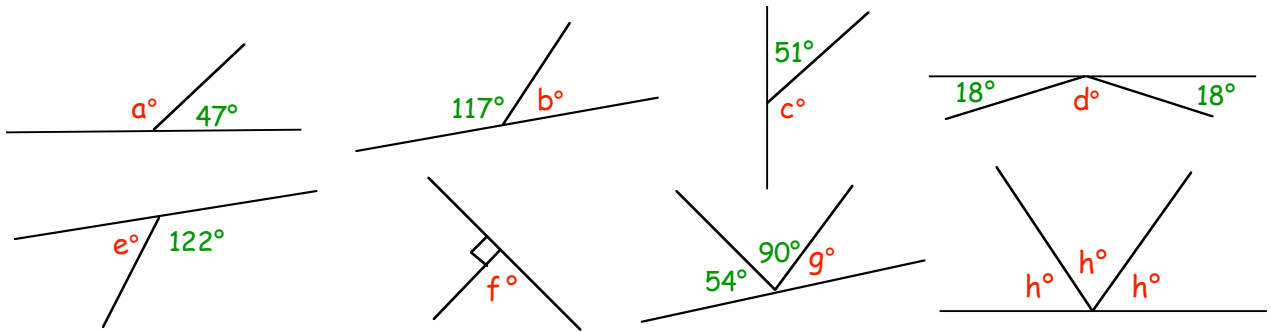

10. The 2 lines in this diagram cross over at point P.

What do you think is **always** true about the angles marked a and b?

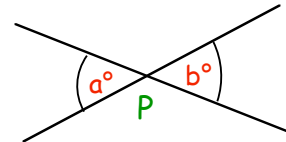

11. In this figure, one angle is 37°.

What is the value of the angle marked \bigcirc ?

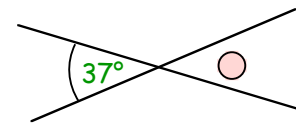

12. Calculate the sizes of the angles marked \bigcirc .

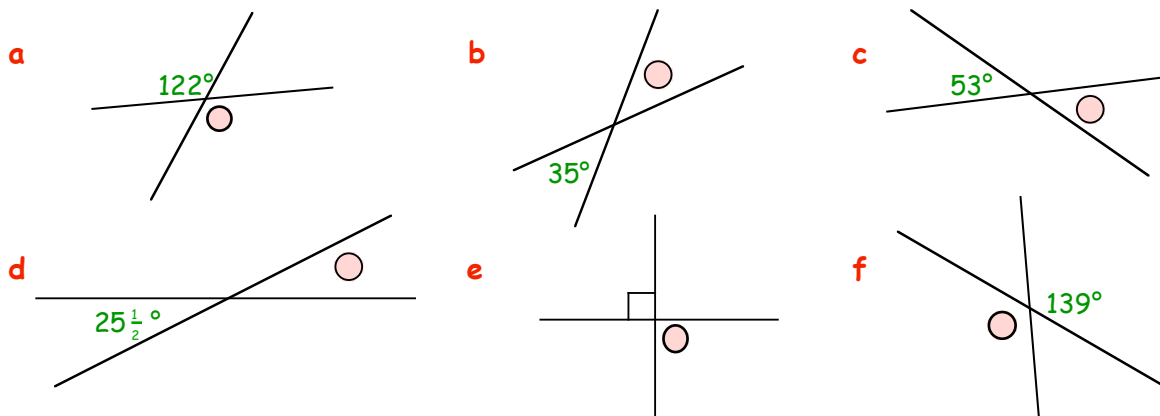

13. In this figure, one angle is 25°.

a Write down the value of **a**.

b Calculate the value of **b**.

(remember)

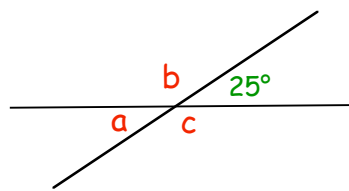

c Now write down the value of **c**.

14. Sketch these figures and fill in the sizes of **all** the angles :-

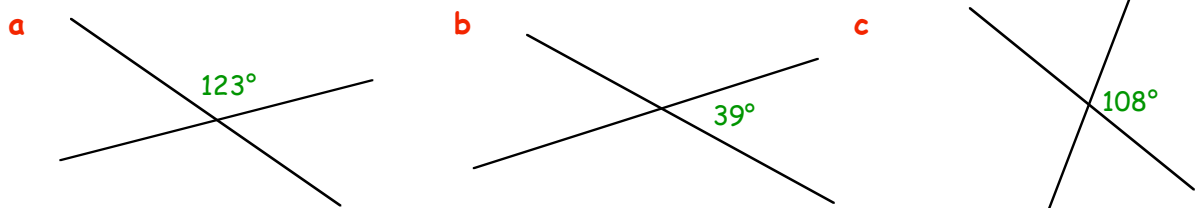

Angles in a Triangle

It is a well known fact in maths that no matter how big a triangle is, if you add all three angles together you always get 180° .

$$\Rightarrow a + b + c = 180^\circ$$

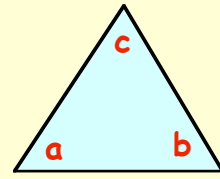

Exercise 4 (You will need a protractor for questions 1 and 2)

- Use a protractor to measure the three angles of this triangle.
 - Add the three angles together.
 - How close to 180° did you get?

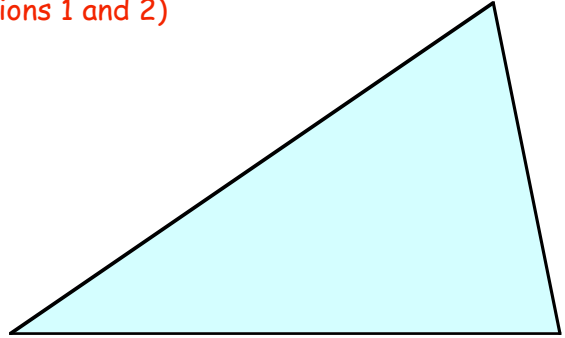

- Draw a triangle of your own - any size, any shape. (make it about half the size of your page)
 - Measure the 3 angles and check that the total comes to (about) 180° .

- In this triangle, what is the value of $40^\circ + 55^\circ$?
 - If all 3 angles add to 180° , what must the 3rd angle be (marked *)?

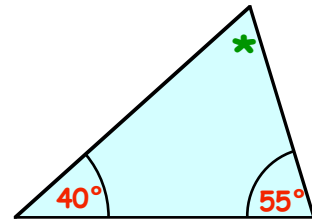

- In each of these triangles, add the 2 given angles together, then calculate the size of the 3rd angle.

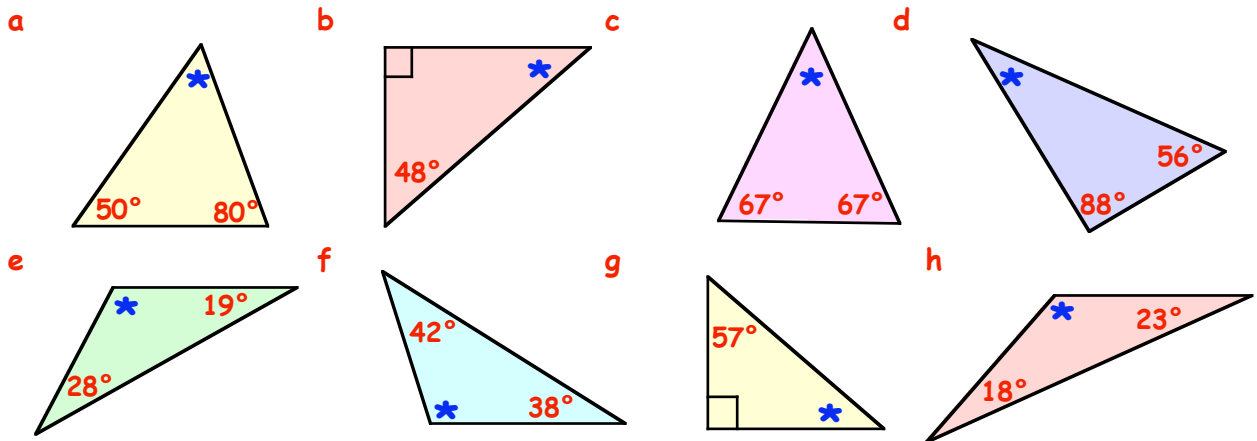

- Use the 140° to help you calculate the size of the angle marked **a**.
 - Now use $\triangle PQR$ to help you find the value of **b**.

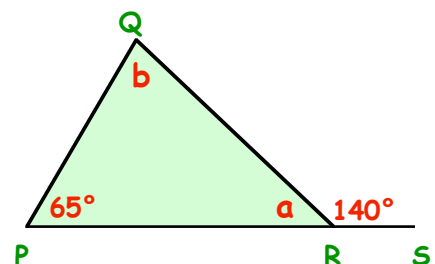

6. Can you remember the special name for this type of triangle?
The two sides (PR and QR) are equal.
The two angles ($\angle RPQ$ and $\angle RQP$) are equal.

It is called an **ISOSCELES** triangle.
Look at the word, cover it up and learn to spell it.

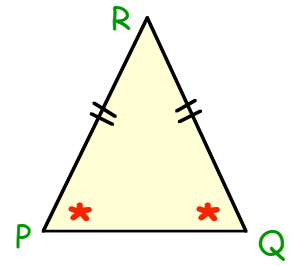

7. An isosceles triangle has 2 angles the same size.
a Write down the value of the angle marked *.
(don't measure it).
b Now calculate the size of the 3rd angle.

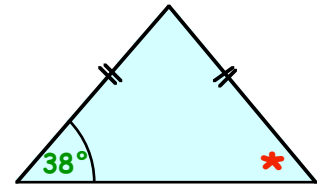

8. Make a small neat sketch of each of these isosceles triangles.
Calculate the sizes of the two missing angles in each triangle :-

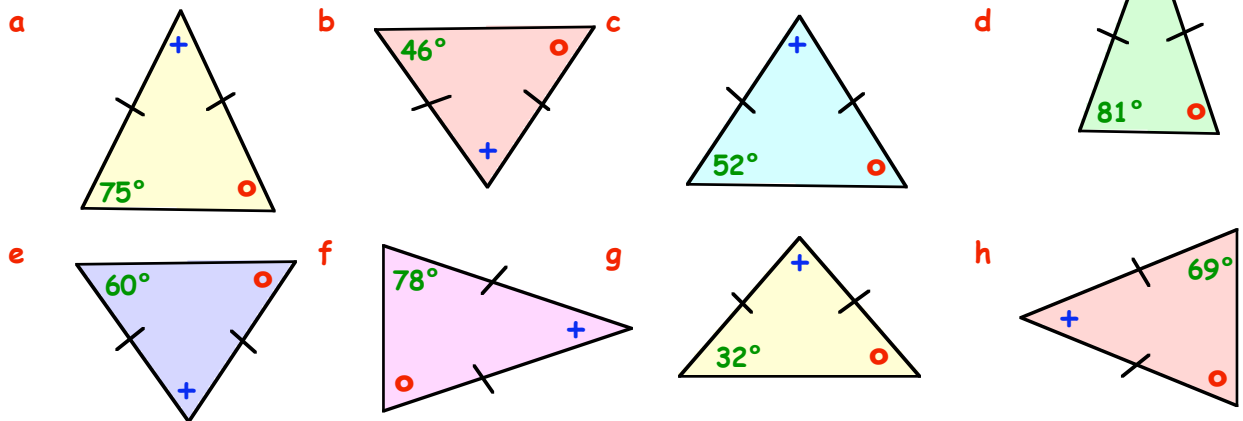

9. $\triangle PQR$ is isosceles.
a If $\angle PQR = 130^\circ$, what is the value of $(a + b)$?
b Since a and b are both the same, what must both a and b be?

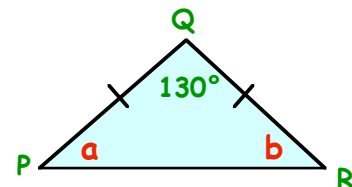

10. Make a neat rough sketch of each of these isosceles triangles.
Calculate the sizes of the two missing angles in each triangle :-

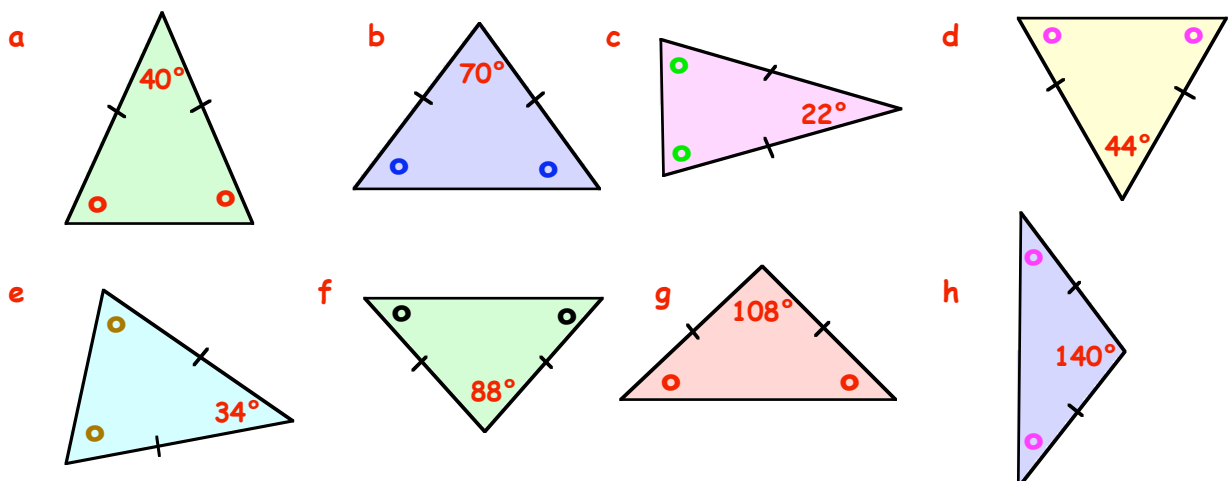

11. $\triangle GFH$ is isosceles. $\angle HGT = 125^\circ$

- a Calculate the size of $\angle HGF$.
- b Calculate the size of $\angle HFG$.
- c Now calculate the size of $\angle GHF$.

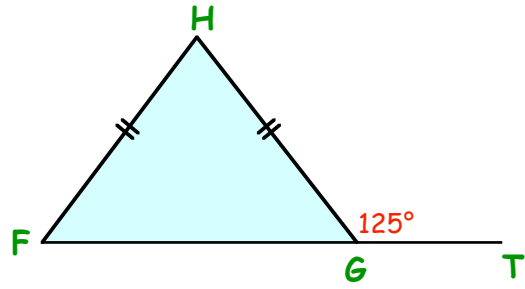

12. Copy each of the following.
Calculate and fill in the sizes of the missing angles :-

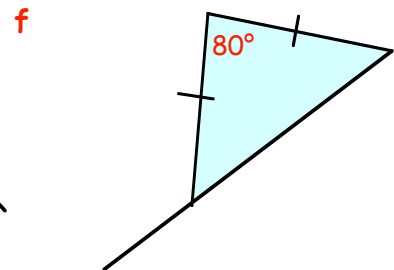
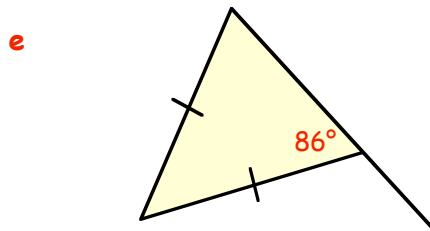
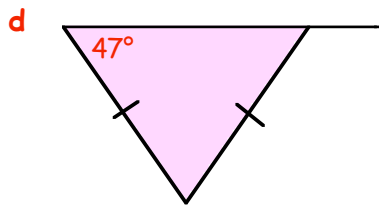
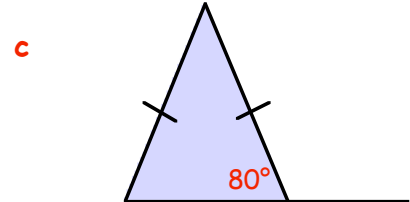
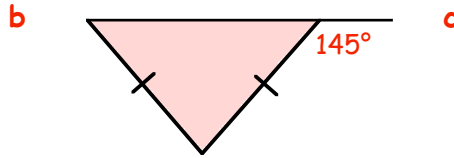
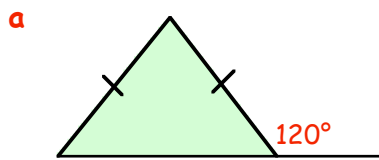

13.

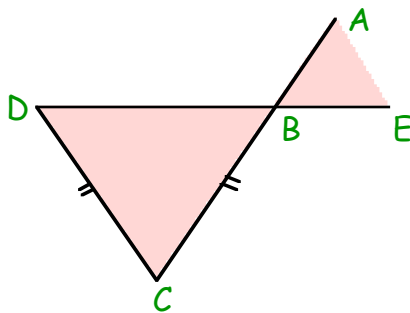

$\triangle BCD$ is isosceles. $BC = DC$. $\angle ABE = 61^\circ$

- a Calculate the size of $\angle DBC$.
- b Write down the size of $\angle BDC$.
- c Finally, what is the size of $\angle BCD$?

14. Copy the following figures and fill in all the missing angles.

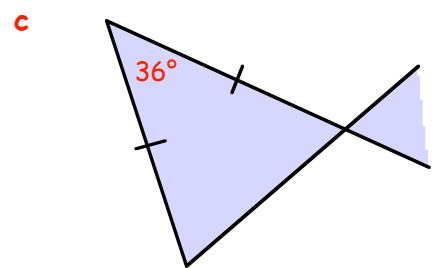
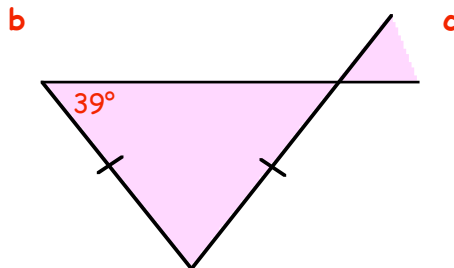
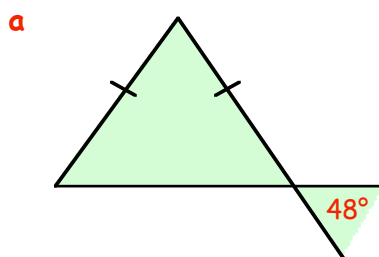

15. This is a very special triangle.
All 3 of its sides are the same length.

a What do we call this type of triangle?

All 3 angles are also the same size.

b Using common sense, calculate the size of each of the 3 angles in this triangle.

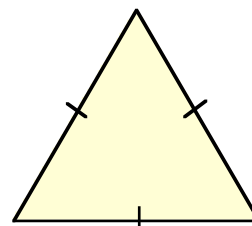

Corresponding Angles

Many mathematical figures have **parallel lines** in them.

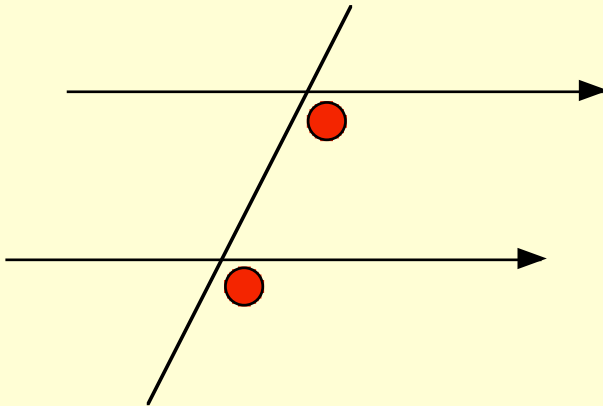

F angles

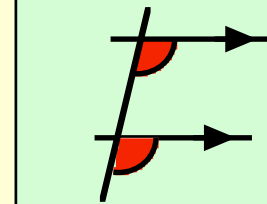

The two angles shown in the above figure are said to be in "**corresponding positions**".

Note :- **corresponding angles are EQUAL.**

Exercise 5

1. Use three letters each time to name the pairs of corresponding angles :-

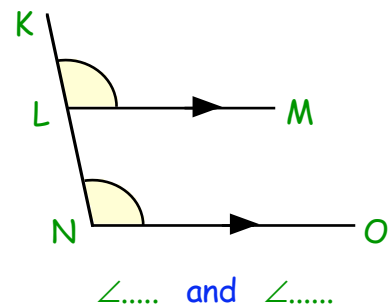
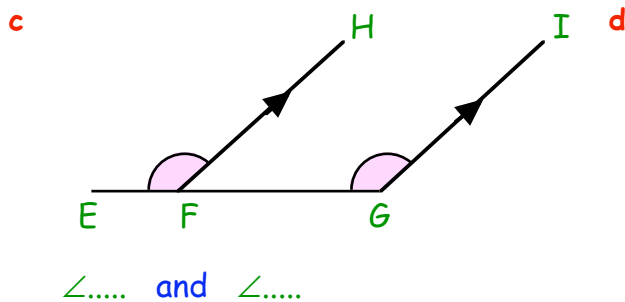
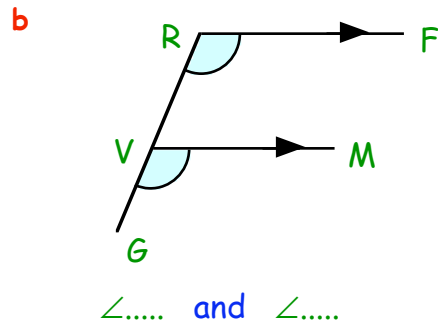
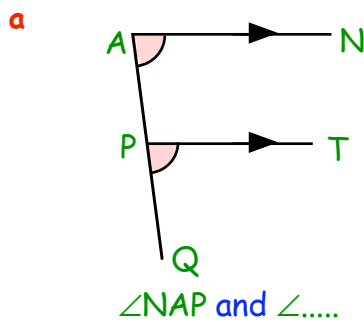

2. In this figure, **j** corresponds to **a**.
Which angle corresponds to :-

a w b f c z?

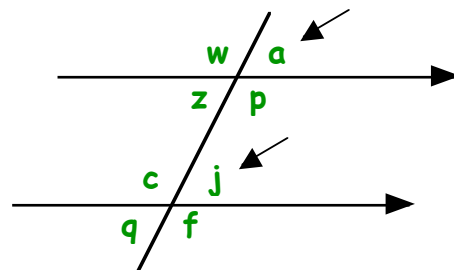

3. COPY the diagrams shown and mark the angles which CORRESPOND to the ones already marked.

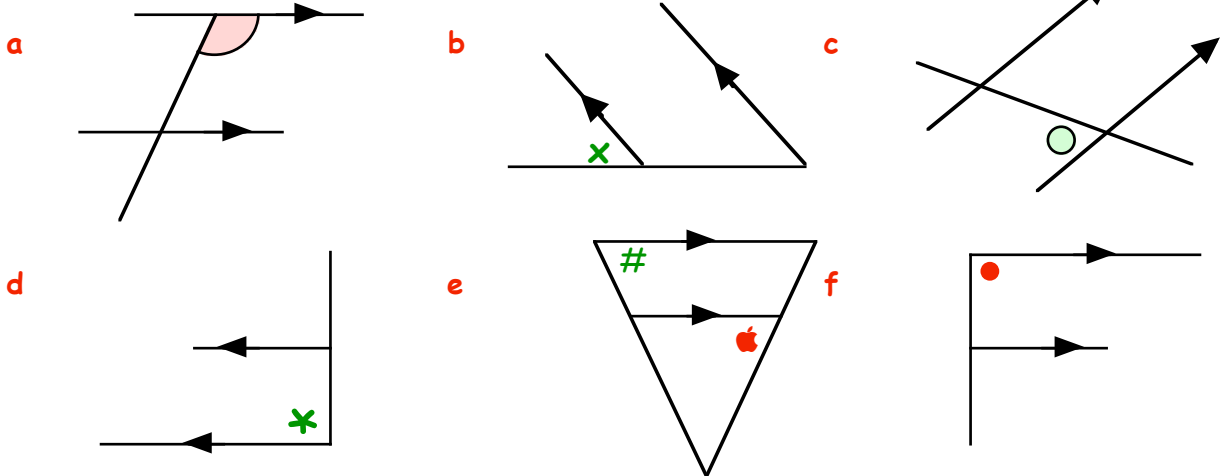

4. Write down the sizes of the angles marked p , q , r ,

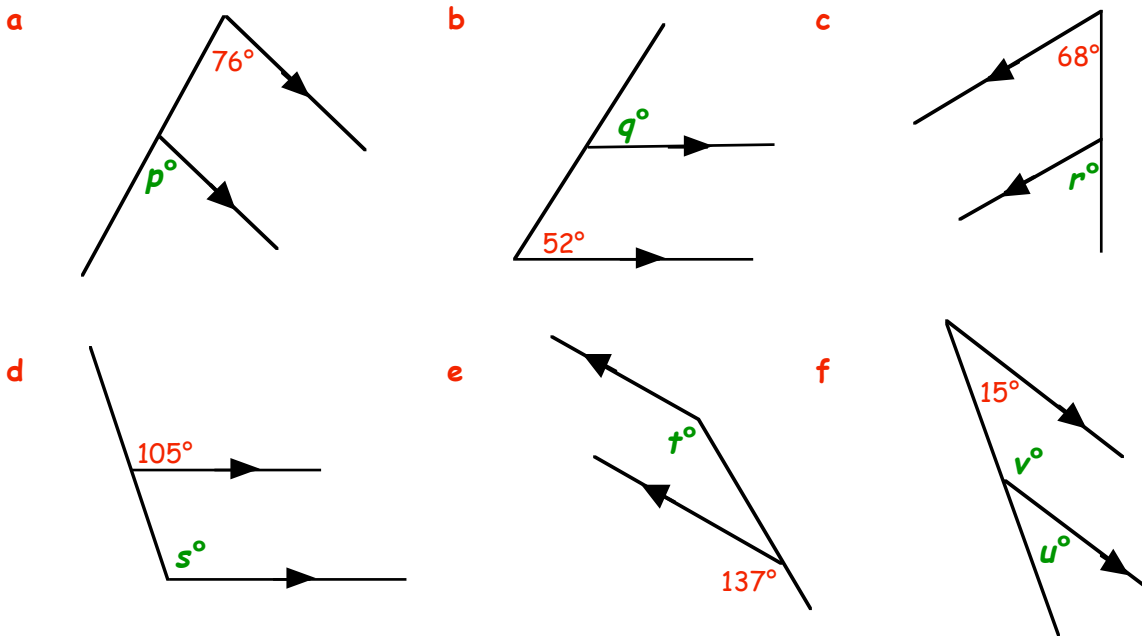

Remember :-

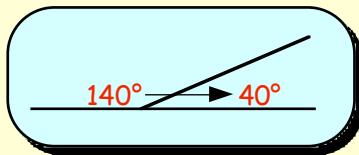

and

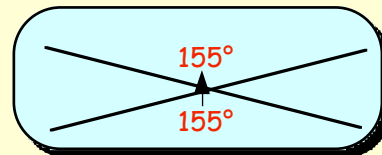

5. Using the above facts and corresponding (F) angles, COPY the diagrams below and enter all the missing angles :-

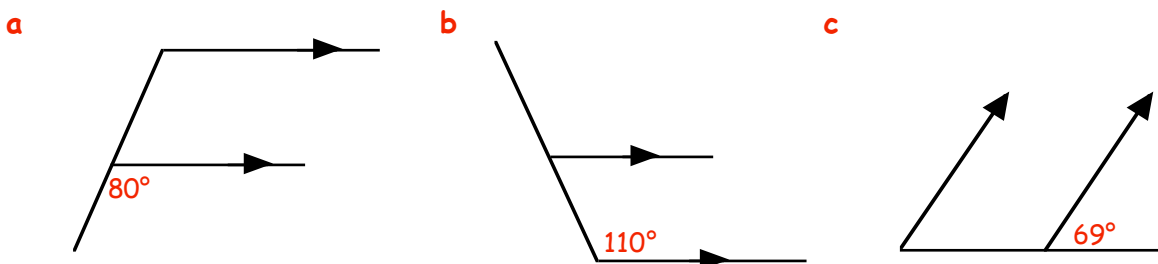

6. Copy the figure shown opposite and fill in the sizes of all the missing angles

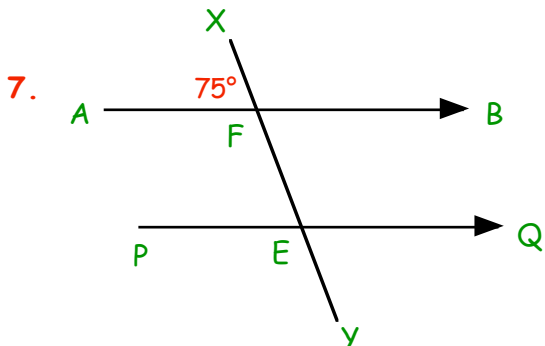
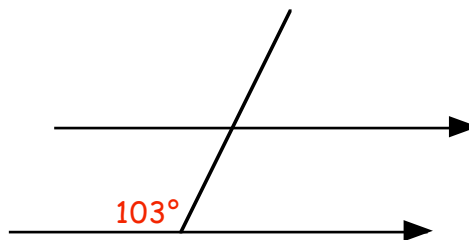

In this figure, $\angle XFA = 75^\circ$.

- Write down the size of $\angle FEP$.
- Make a neat sketch of the figure and calculate the sizes of all the other angles.

8. Sketch each of the following and fill in all the missing angles :-

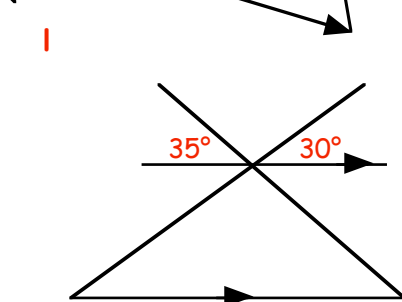
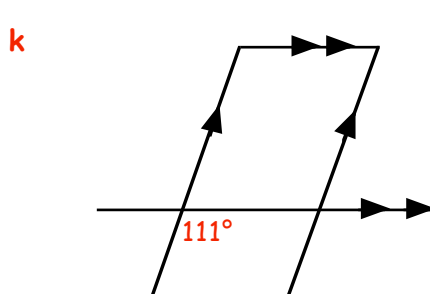
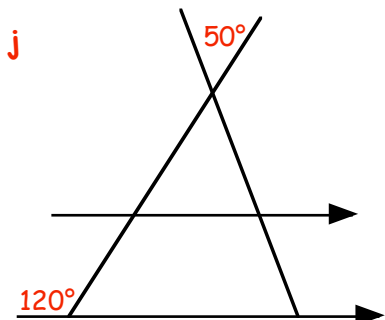
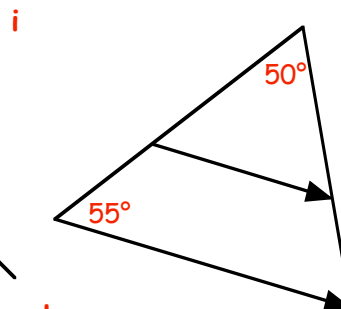
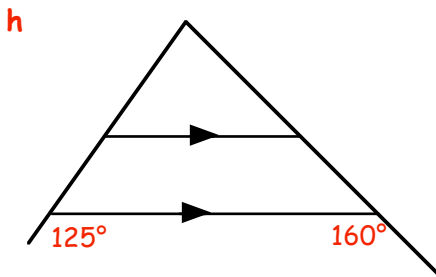
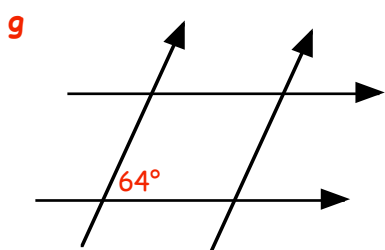
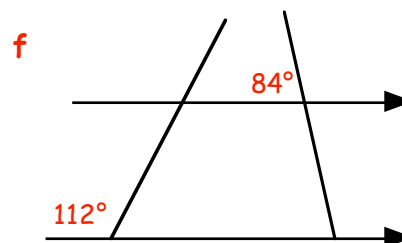
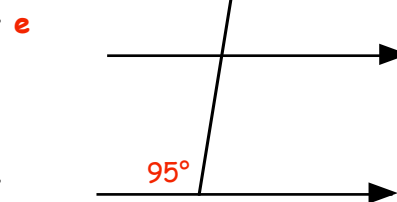
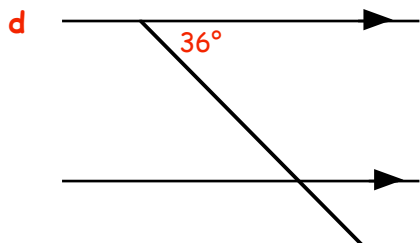
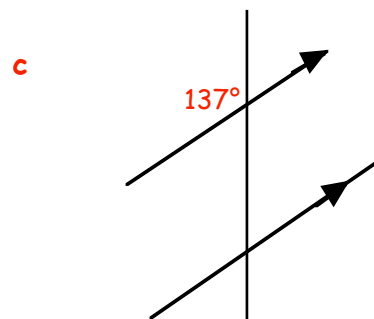
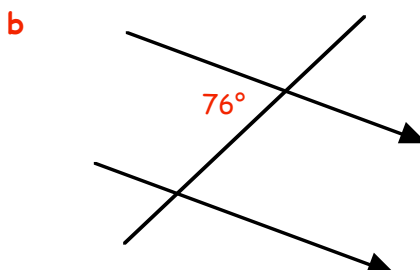
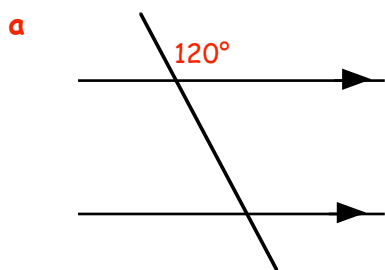

Alternate Angles

If a pair of parallel lines have a line joining them, a Z-shape is formed :-

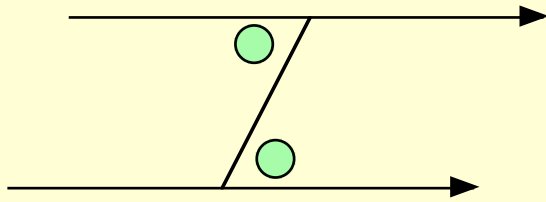

Z angles

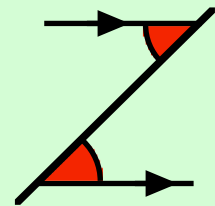

The two angles shown in the above figure are said to be in "alternate positions".

Note :- alternate angles are EQUAL.

Exercise 6

1. Make a neat sketch of each of these figures and mark the angle which is alternate to the one already marked :-

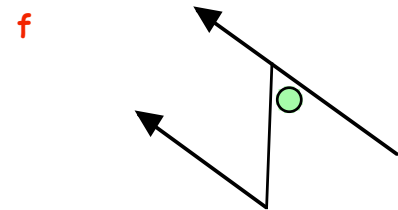
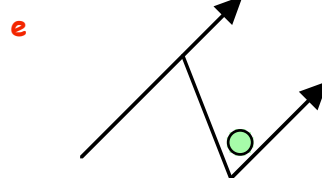
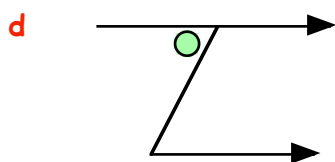
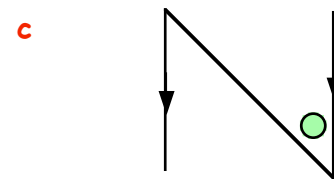
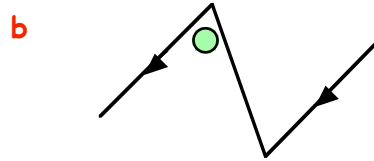
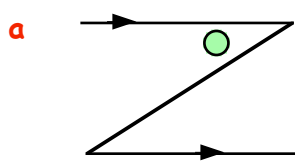

2. Use three letters each time to name the pairs of alternate angles :-

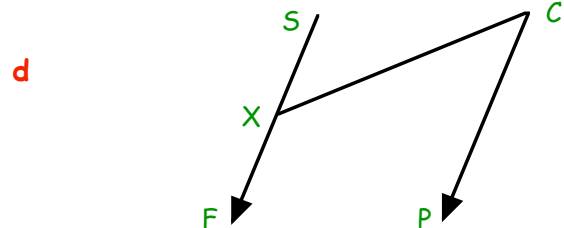
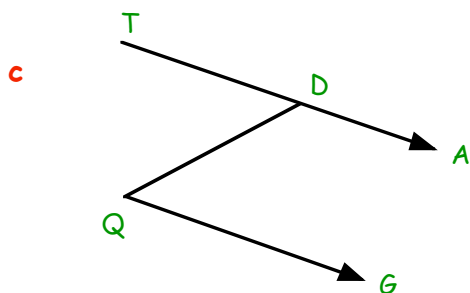
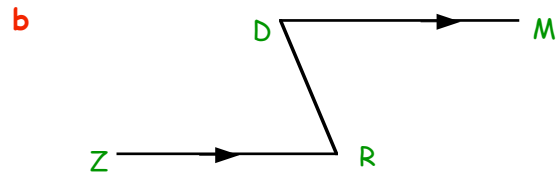
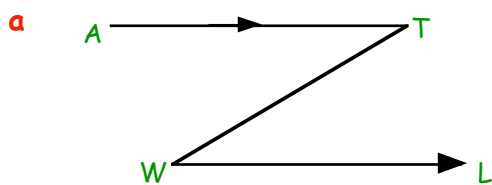

3. In this figure, which angle is **alternate** to :-

a z **b c** ?

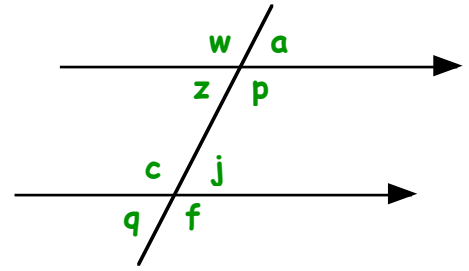

4. Write down the values of **a, b, c, d, e** and **f** :-

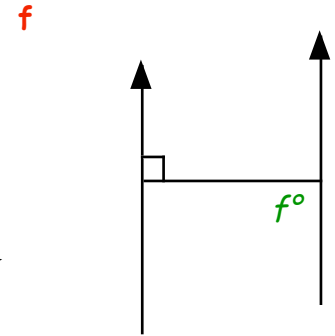
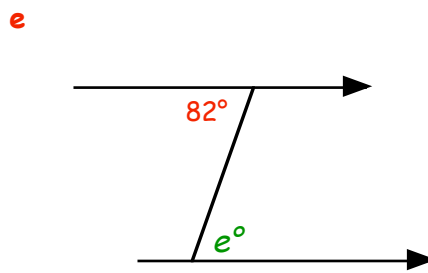
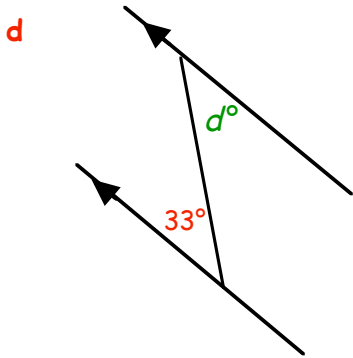
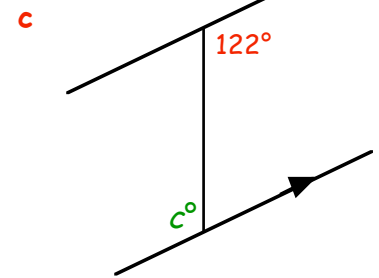
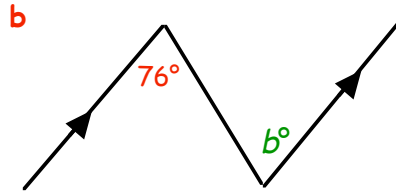
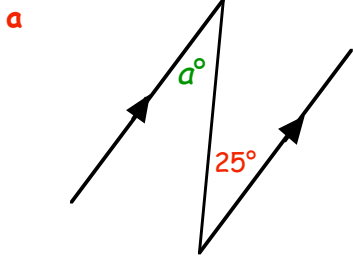

5. Copy the figure shown opposite.
Fill in the sizes of all the missing angles.

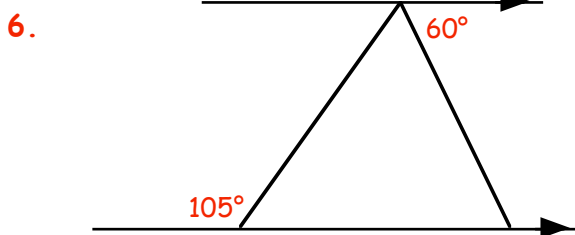
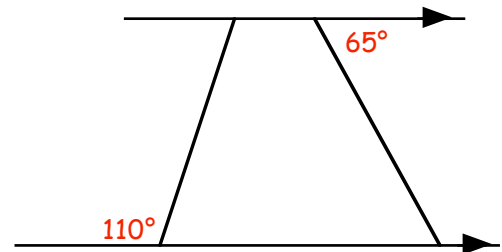

Make a neat copy of this figure and fill in all the missing angles.

7. Make a neat copy of this figure and fill in all the missing angles.

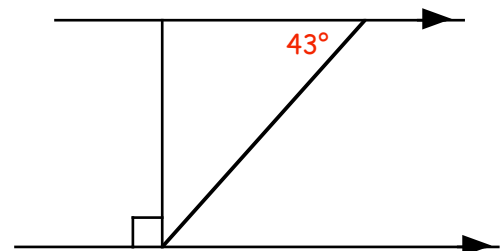

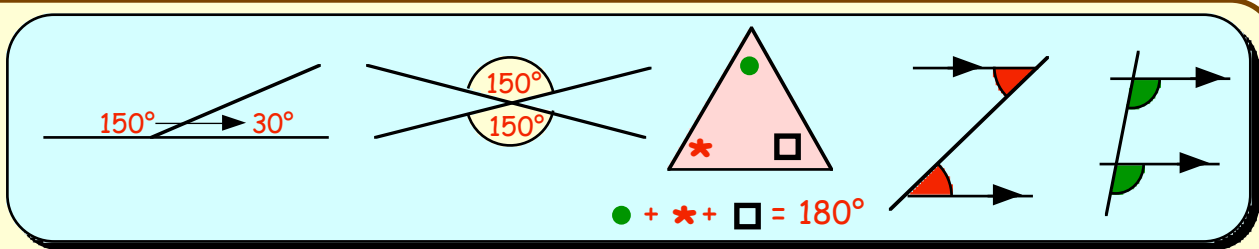

Using the above facts along with **corresponding** and **alternate** angles, **COPY** the following diagrams **NEATLY** and mark in all the missing angles :-

8. Remember (again !) :-

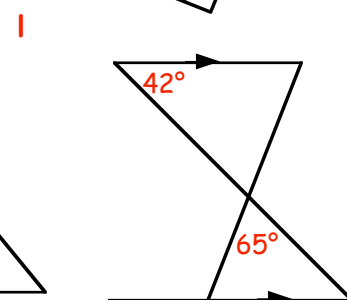
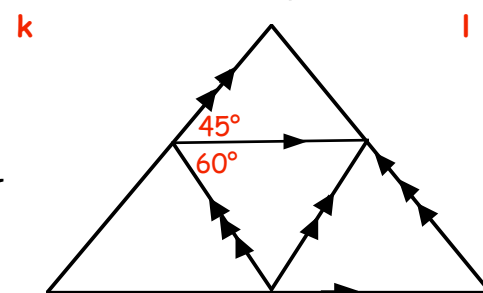
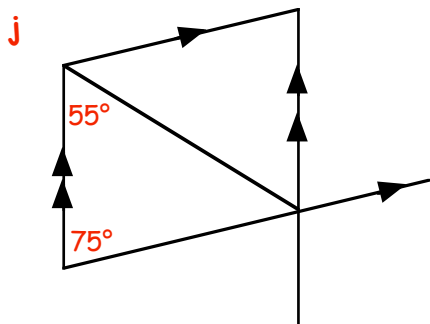
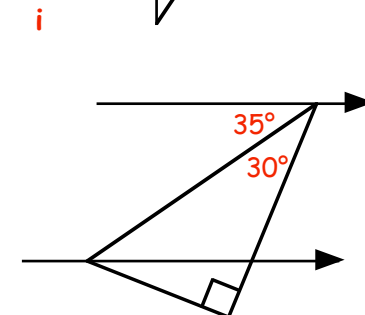
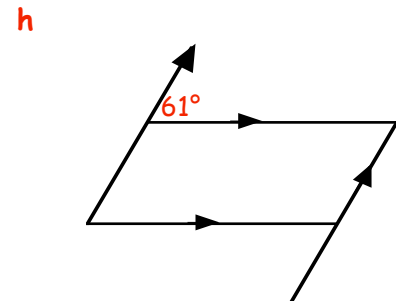
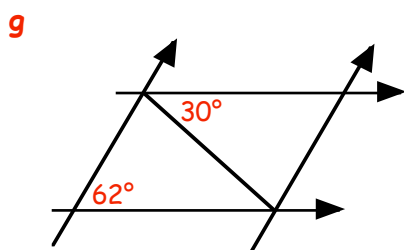
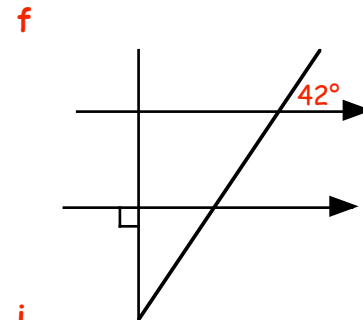
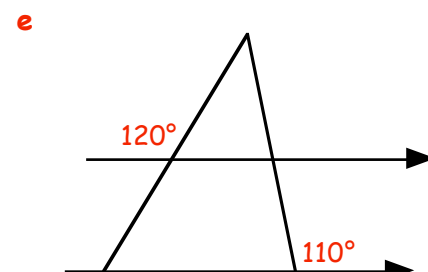
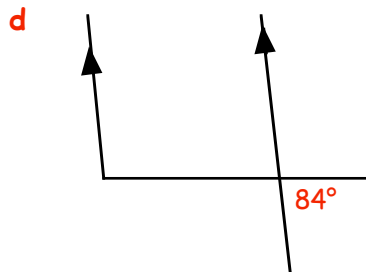
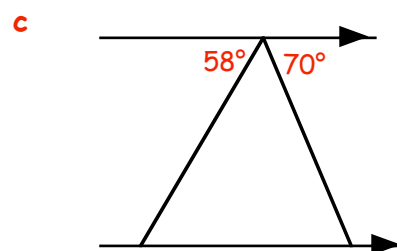
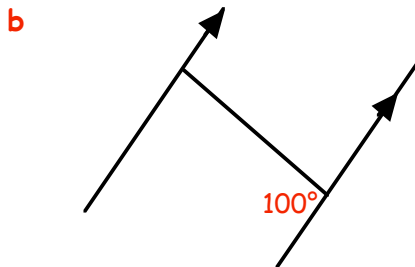
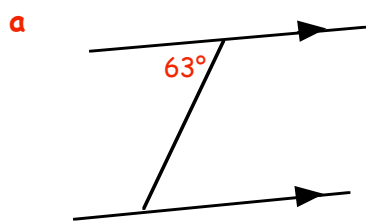

9. (Difficult !) Calculate the size of the shaded angle in the diagram.

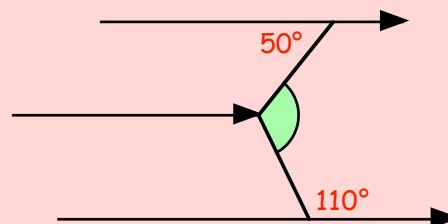

Topic in a Nutshell

1. Use a word from "Acute, Right, Obtuse, Straight or Reflex" to describe these angles :-

a

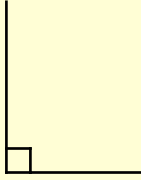

b

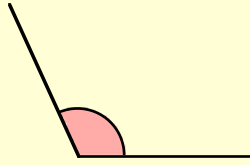

c

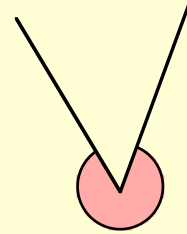

d

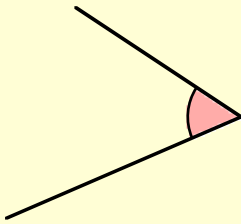

e

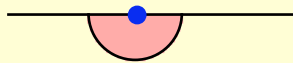

2. Look at the angles listed below.

173°, 77°, 55°, 125°, 14°, 180°, 220°, 157°, 93°, 90°, 340°, 40°

Which of the angles are :-

a Acute ?

b Straight ?

c Obtuse ?

d Right ?

e Reflex ?

3. Use 3 letters to name each angle:-

a

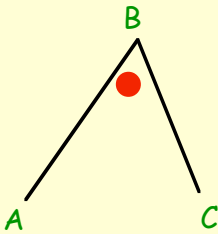

b

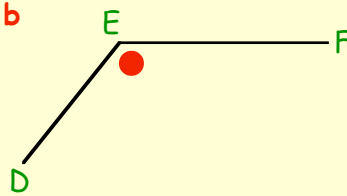

c

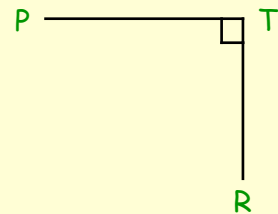

d

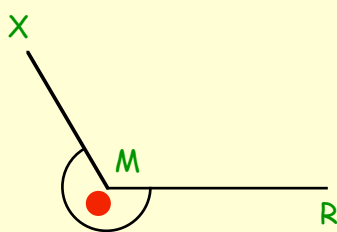

e

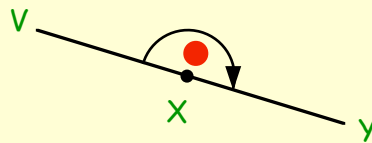

4. For this triangle, NAME the angle marked :-

a * .

b ● .

c ■ .

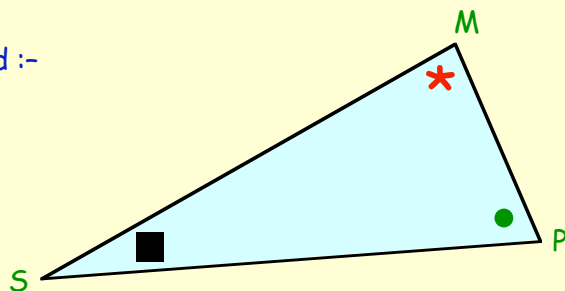

5. Work out the sizes of the angles marked ● .
(Do not measure them)

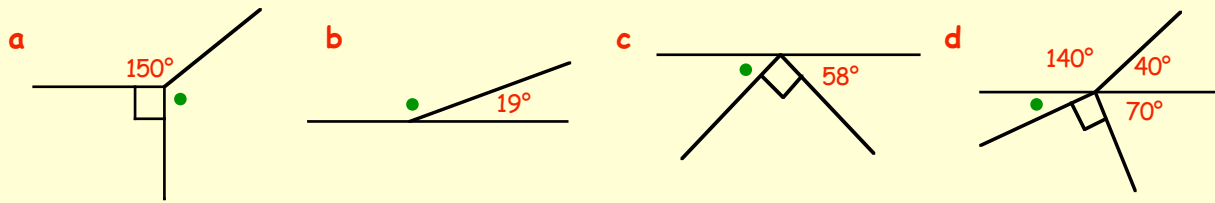

6. Write down the supplement of 148° .

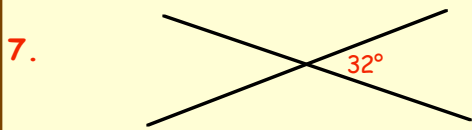

Sketch this figure and fill in the sizes of the three missing angles.

8. Calculate the sizes of angles *a* and *b* in this triangle.

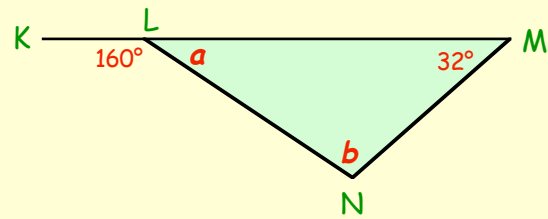

9. Make a sketch of the two triangles shown below and write in the sizes of the two missing angles in each triangle.

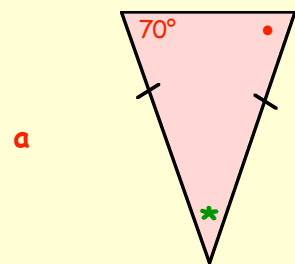
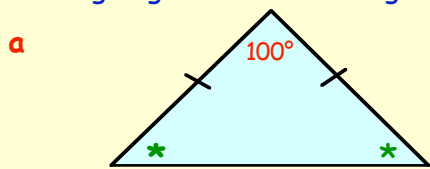

10. Copy the figure shown opposite and fill in the sizes of **ALL** the missing angles.

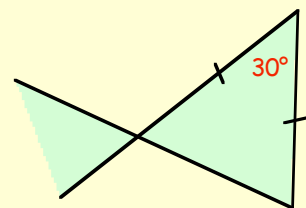

11. Sketch each of the following and fill in the missing angles :-

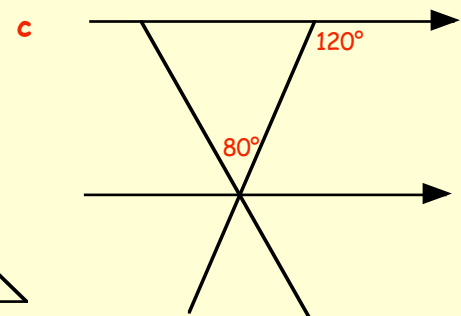
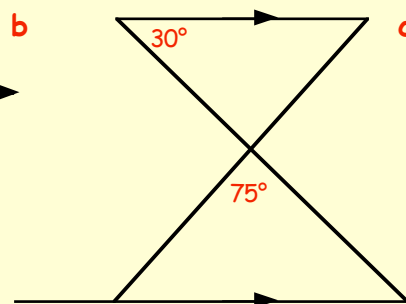
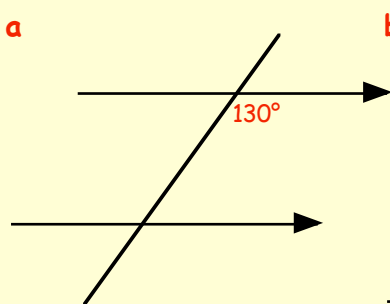

Chapter 13



Multiples

When you multiply a whole number by 5 the **answer** is called a **multiple of 5**.

$$5 \times 0 = 0, \quad 5 \times 1 = 5, \quad 5 \times 2 = 10, \quad 5 \times 3 = 15, \quad 5 \times 4 = 20, \quad \dots$$

So, the multiples of 5 are **0, 5, 10, 15, 20, 25, ...**

(from now on we will disregard 0 which is a trivial multiple).

Exercise 1

- Write down the first six multiples of 4, starting with 4, 8,
- Write down the first six multiples of 7, starting with 7, 14, ...
- Write down the first ten multiples of 8 starting with 8
- Say which of the following statements are **true** and which are **false** :-
 - 28 is a multiple of 7
 - 35 is a multiple of 6
 - 42 is a multiple of 6
 - 90 is a multiple of 5
 - 72 is a multiple of 8
 - 54 is a multiple of 7
 - 121 is a multiple of 11
 - 600 is a multiple of 20
- From the following list of numbers, say which boxes each number could be placed in.
(Some numbers can go in more than one box)
12, 14, 16, 18, 20, 24, 28, 30, 32, 33, 35, 36, 38, 40, 42, 44, 45, 48, 49, 50, 52, 54.

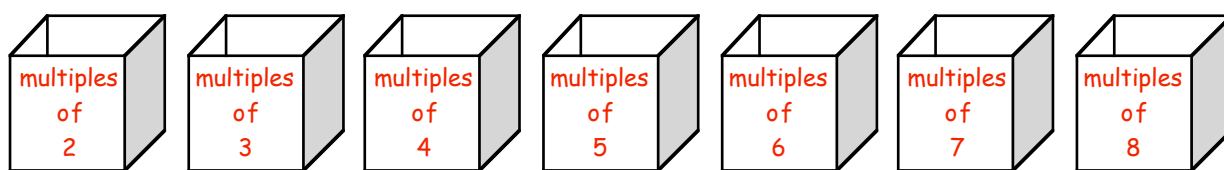

- Make a list of :-
 - the multiples of 3 between 20 and 40
 - the multiples of 5 between 12 and 52
 - the multiples of 4 between 15 and 35
 - the multiples of 7 between 10 and 50
- Write down the first ten (non-zero) multiples of 4. {4, 8, ... }
 - Write down the first ten (non-zero) multiples of 6. {6, 12, ... }
 - Write down all the numbers which appear in both lists (multiples of 4 and of 6).
 - These are called the "common multiples" of 4 and 6.
What is the smallest (the lowest) multiple they have in common?
This is called the **lowest common multiple** of 4 and 6, (or the **l.c.m.** of 4 and 6).

8. a Write down the first ten multiples of 2.
 b Write down the first ten multiples of 3.
 c Write down all the numbers which appear in both lists (multiples of 2 and of 3).
 d What is the **lowest common multiple** of 2 and 3, (or the **l.c.m.** of 2 and 3).
9. By writing down the multiples of 6 and 8, find the **l.c.m.** of 6 and 8.
10. Find the l.c.m. of the following pairs of numbers :-
- | | | |
|------------|-------------|-------------|
| a 4 and 5 | b 6 and 9 | c 2 and 5 |
| d 8 and 10 | e 5 and 6 | f 3 and 5 |
| g 6 and 10 | h 10 and 12 | i 5 and 10. |
11. Find the l.c.m. of the following sets of numbers
- | | | |
|--------------|--------------|--------------|
| a 2, 3 and 4 | b 3, 4 and 5 | c 3, 4 and 6 |
| d 4, 6 and 8 | e 2, 5 and 6 | f 5, 6 and 7 |
12. At a disco, the red light flashes every 4 seconds, the blue light flashes every 5 seconds and the yellow light flashes every 6 seconds.
 At a certain moment in time, all 3 lights flash at the same time.
- a How many seconds pass before they all flash together again ?
 b When is the next time after that they flash together again ?



Factors

When you can divide a given number by a second number **exactly**, with no remainder, then that second number is called a **factor** of the first number.

The factors of 8 are 1, 2, 4, 8,

because 1, 2, 4 and 8 can divide exactly into 8 and leave no remainder.

Exercise 2

1. Write down the **two** factors of 7.
2. Write down all **four** factors of 10.
3. Write down the
- | | | |
|----------------------|----------------------|-----------------------|
| a three factors of 9 | b two factors of 13 | c four factors of 15 |
| d six factors of 18 | e five factors of 16 | f eight factors of 24 |

4. Find all the factors of the following numbers :-

a 8 b 20 c 25 d 30 e 32

5. Which of the following statements are true and which are false :-

a 7 is a factor of 28 b 5 is a factor of 36
c 2 is a factor of 71 d 3 is a factor of 27
e 6 is a factor of 100 f 4 is a factor of 80
g 10 is a factor of 2115 h 8 is a factor of 84

6. Which of the following numbers could go into which factor cases :-
(some numbers can go in more than one case)

1, 2, 3, 4, 5, 6, 7, 8, 9, 10, 11, 12, 13, 14, 15, 16, 17, 18,

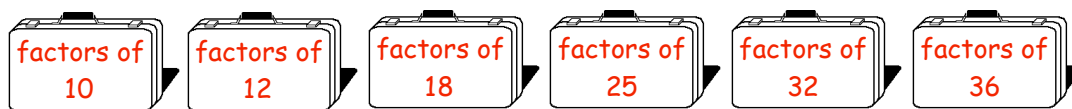

7. a Make a list of all **six** factors of 12.
b Write down all **five** factors of 16.
c Which factors appear on both lists? (these are the **common factors** of 12 and 16).
d What is the **highest common factor** (or the **h.c.f.**)?

8. a Make a list of all the factors of 20.
b Write down all the factors of 30.
c Make a list of the common factors of 20 and 30.
d What is highest common factor of 20 and 30?

9. Find the h.c.f. of the following :-

a 6 and 8 b 10 and 15 c 12 and 18
d 8 and 20 e 20 and 35 f 30 and 42
g 60 and 80 h 31 and 41 i 36 and 54.

10. Find the h.c.f. of the following :-

a 4, 6 and 8 b 10, 15 and 20 c 12, 16 and 28
d 24, 32 and 48 e 18, 45 and 63 f 32, 48 and 96

11. Make sure you know the difference between the h.c.f. and the l.c.m. of two numbers.

a What is the h.c.f. of (i) 8 and 10 (ii) 6 and 15 (iii) 12 and 18 ?
b What is the l.c.m. of (i) 8 and 10 (ii) 6 and 15 (iii) 12 and 18 ?

Prime Numbers

A number which has **exactly 2 factors**, (itself and 1), is called a **Prime Number**.

Primes are some of the most important and interesting of numbers, and are studied and researched at University level and beyond.

2, 3, 5, 7, 11 are examples of prime numbers. Note :- 9 is **NOT prime** (since $9 = 3 \times 3$)

The **lowest prime number is 2**.

The only **EVEN prime number is 2**.

To check whether a number, like 21, is **prime** or not, ask yourself the simple question :-

"Can 21 be divided **exactly** by any other number except 1 and 21?"

If the answer is "NO", then 21 **is** a prime

But in this case, since 21 can be divided by 3 \Rightarrow 21 is **not** a prime

Exercise 3

- Can the number 15 be divided by any other number (other than 1 and 15)?
 - Is 15 a prime or not?
- Can the number 23 be divided by any other number (other than 1 and 23)?
 - Is 23 a prime or not?
- Why is the number "1" definitely **NOT** a prime number?
(look at the definition given in line 1 at the top of this page).
- Write down all the numbers from 1 to 10
 - Go through them one at a time, score out all the **non-primes**, and make a list of all the primes from 1 to 10.
- Now write down all the numbers from 11 to 20.
 - Go through these one at a time, score out all the **non-primes**, and make a list of all the primes from 11 to 20.
- Decide which of the following numbers are primes by checking for factors other than the number itself and 1 :-
 - 7
 - 19
 - 27
 - 35
 - 29
 - 52
 - 49
 - 61
 - 39
 - 99



7. The "Sieve Of Eratosthenes" can be used to find all the primes between 1 and 100.

Copy

1	2	3	4	5	6	7	8	9	10
11	12	13	14	15	16	17	18	19	20
21	22	23	24	25	26	27	28	29	30
31	32	33	34	35	36	37	38	39	40
41	42	43	44	45	46	47	48	49	50
51	52	53	54	55	56	57	58	59	60
61	62	63	64	65	66	67	68	69	70
71	72	73	74	75	76	77	78	79	80
81	82	83	84	85	86	87	88	89	90
91	92	93	94	95	96	97	98	99	100

- a Make a neat large copy of this number square showing all the numbers from 1 to 100.
- b **On your copy**, score out 1 - it is not a prime.
- c Circle the 2 - score out every other multiple of 2 - (4, 6, 8, 100).
- d Circle the 3 - score out every other multiple of 3 - (6, 9, 12, 99).
- e Circle the 5 - score out every other multiple of 5 - (10, 15, 20, 95).
- f Circle the 7 - score out every other multiple of 7 - (14, 21, 28, 98).
- g Now circle every remaining number in the square. These are all the prime numbers.
- h Make a neat list of all the primes from 1 to 100. (there are exactly 25 of them !)

8. Prime Decomposition.

If a number is not a prime number, it is called a **composite** number.

COMPOSITE numbers can be re-written as a product of prime numbers as follows by producing what are referred to as **factor trees** :-

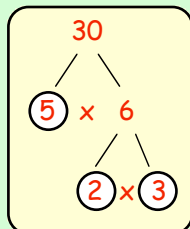

$30 = 5 \times 2 \times 3$

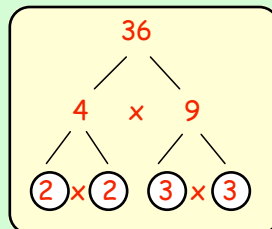

$36 = 2 \times 2 \times 3 \times 3$

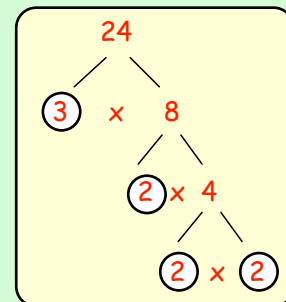

$24 = 2 \times 2 \times 2 \times 3$

Copy this "factor tree" and complete it to find all the prime factors of 60.

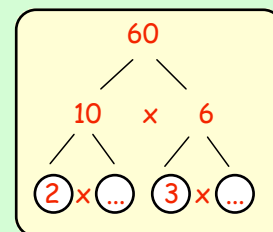

$60 = \dots \times \dots \times \dots \times \dots$

9. Use the above method to find all the prime factors of :-

- a 12 b 18 c 20 d 28 e 32
- f 40 g 56 h 54 i 72 j 120

Chapter 14

Drawing Triangles

Constructing Triangles

There are 2 ways of drawing triangles :-

- Making a rough sketch.
- Making an **accurate drawing** using a ruler, a pair of compasses and a protractor.

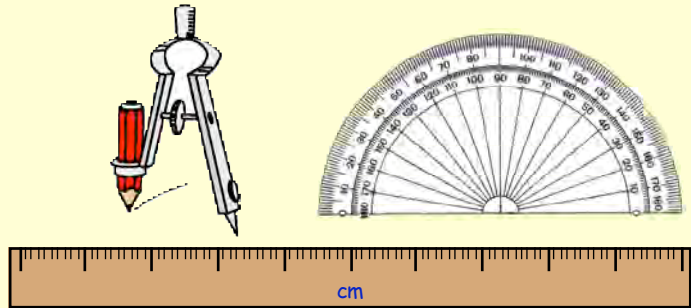

You need to be given **3 pieces of information** about a triangle before you can begin to draw it.

A. Two Sides and the Included Angle

(the angle between the 2 sides)

Shown opposite is a **rough sketch** of $\triangle ABC$.

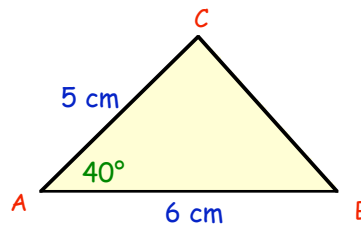

To draw it accurately :-

Step 1 :- Draw line $AB = 6$ cm.

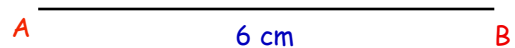

Step 2 :- Put your protractor at A and mark an angle of 40° .

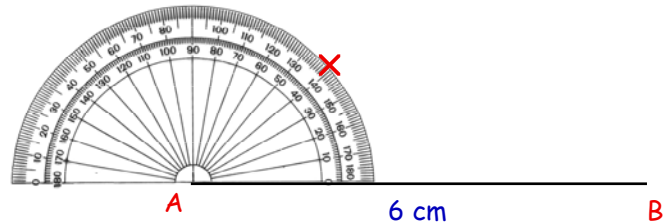

Step 3 :- Draw line AC , from A through the X , to point C .
Make sure it is 5 centimetres long.

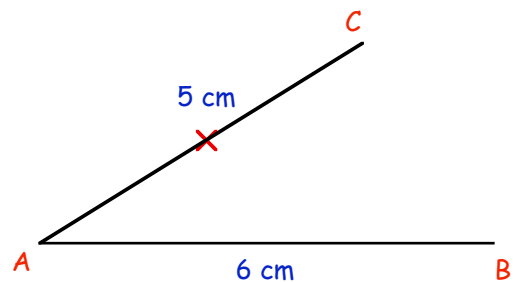

Step 4 :- Join B to C to complete the triangle.

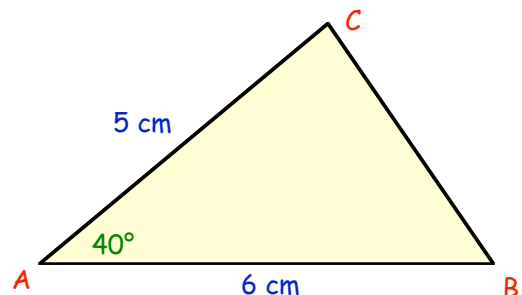

Exercise 1 (You WILL need a **ruler** and a **protractor** for this exercise).

1. On the right is a rough sketch of $\triangle PQR$.

Follow the instructions to draw it **accurately** :-

- Step 1** :- Draw line $PQ = 8$ cm.
- Step 2** :- Put your protractor at P and mark (with an X) an angle of 65° .
- Step 3** :- Draw line PR, from P through the X, to point R.
(Make sure it is 6 centimetres long).
- Step 4** :- Join R to Q to complete the triangle,

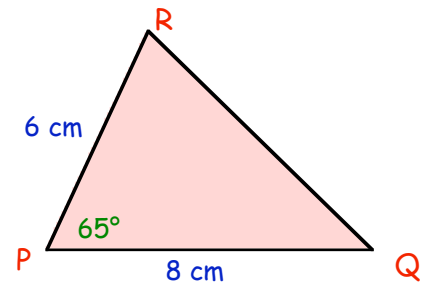

2.

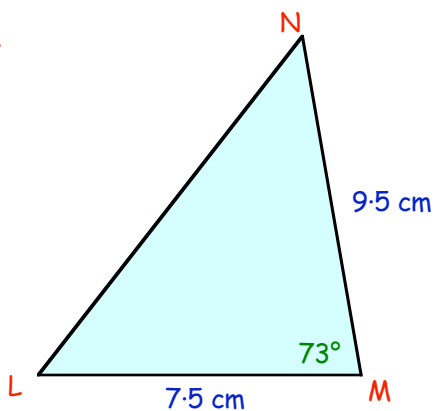

Shown is a sketch of $\triangle LMN$.
Draw it **accurately** using the following instructions :-

- Step 1** :- Draw line $LM = 7.5$ cm.
- Step 2** :- Put your protractor at M and mark (with an X) an angle of 73° .
- Step 3** :- Draw line MN, from M through the X, to point N.
(Make sure it is 9.5 centimetres long).
- Step 4** :- Join N to L to complete the triangle,

3. Make **accurate** drawings of the following triangles :-

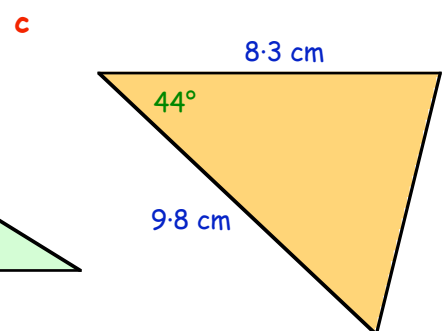
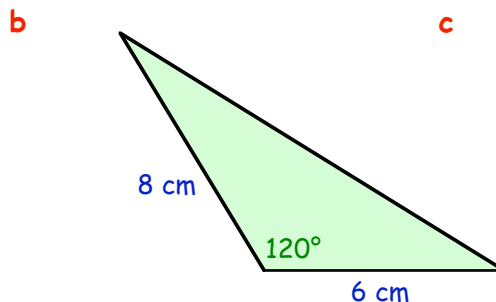
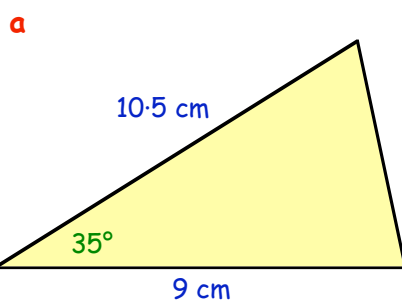

4. Make **accurate** drawings of the following triangles :-

(You might like to make **rough sketches** of the triangles first before drawing them).

- a Draw $\triangle PMN$ where $MN = 11$ cm, $MP = 9$ cm and $\angle NMP = 50^\circ$.
- b Draw $\triangle RST$ where $ST = 7.8$ cm, $SR = 8.3$ cm and $\angle RST = 77^\circ$.
- c Draw $\triangle WXY$ where $WX = 95$ mm, $WY = 80$ mm and $\angle XWY = 34^\circ$.
- d Draw $\triangle TAN$ where $AN = 15$ cm, $AT = 8.6$ cm and $\angle TAN = 105^\circ$.
- e Draw $\triangle EQJ$ where $EQ = JQ = 10$ cm and $\angle EQJ = 64^\circ$.

B. Two Angles and a Side

Shown opposite is a rough sketch of $\triangle PQR$.

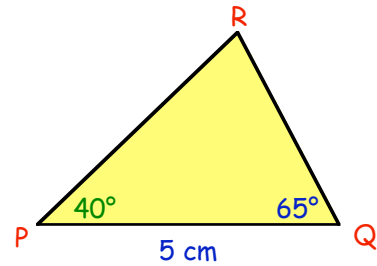

To draw it accurately :-

Step 1 :- Draw line $PQ = 5$ cm.

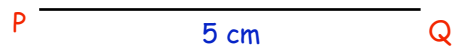

Step 2 :- Put your protractor at P and mark an angle of 40°.

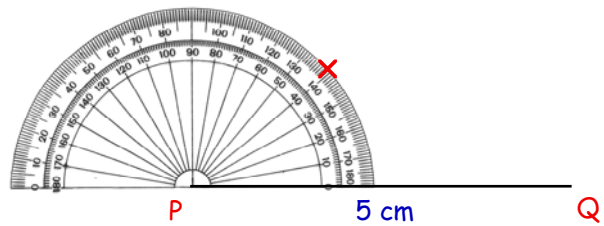

Step 3 :- Draw line from P through the point X.

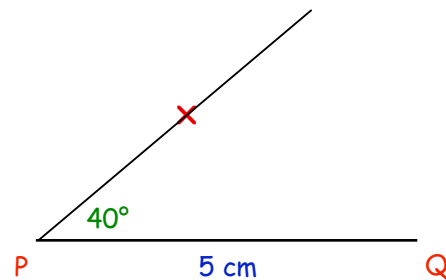

Step 4 :- Now put your protractor at Q and mark an angle of 65°.

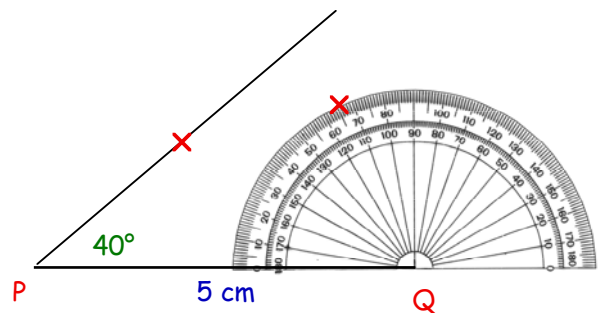

Step 5 :- Finally, draw the line from Q through your new X point.
(Mark the point where the two lines meet with the letter R).

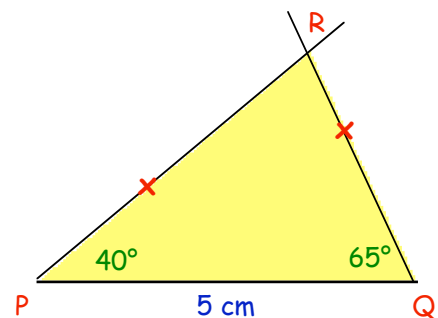

Exercise 2 (You WILL need a ruler and a protractor for this exercise)

1. On the right is a rough sketch of $\triangle EFG$.

Follow the instructions to draw it **accurately** :-

Step 1 :- Draw line $EF = 8$ cm.

Step 2 :- Put your protractor at E and mark (with an X) an angle of 60° .

Step 3 :- Draw a line from E through the X,

Step 4 :- Put your protractor at F and mark (with an X) an angle of 35° .

Step 5 :- Draw a line from F through the X, to meet your first line at point G.

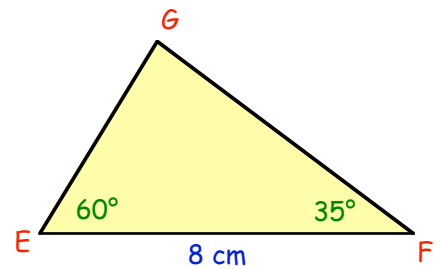

2.

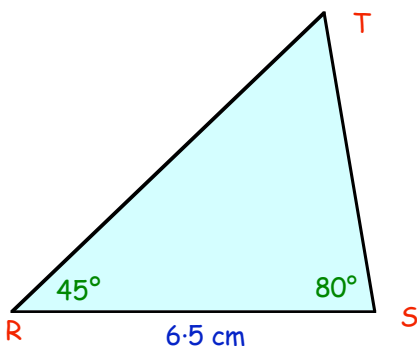

Shown is a sketch of $\triangle RST$.

Draw it **accurately** using the following instructions :-

Step 1 :- Draw line $RS = 6.5$ cm.

Step 2 :- Put your protractor at R and mark (with an X) an angle of 45° .

Step 3 :- Draw a line from R through the point X.

Step 4 :- Put your protractor at S and mark (with an X) an angle of 80° .

Step 5 :- Draw a line from S through the point X and mark where the 2 lines cross with a T.

3. Make **accurate** drawings of the following triangles :-

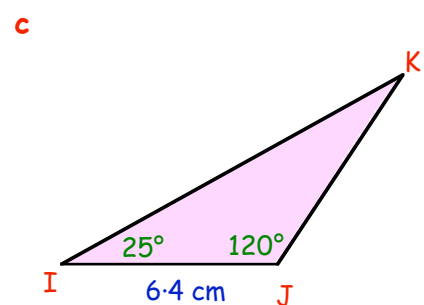
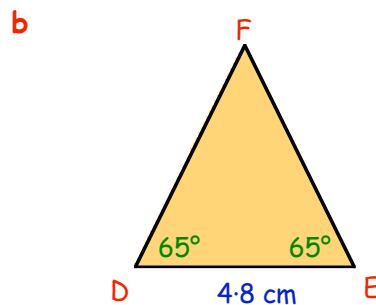
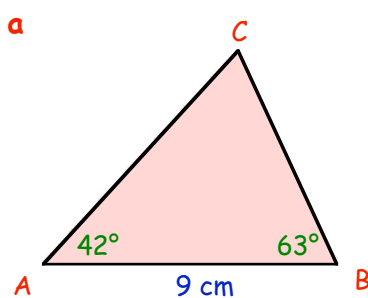

4. Make **accurate** drawings of the following triangles :-

(You might like to make **rough sketches** of the triangles first before drawing them).

a Draw $\triangle XYZ$ where $XY = 11$ cm, $\angle ZXY = 60^\circ$ and $\angle ZYX = 70^\circ$.

b Draw $\triangle RGA$ where $RG = 10$ cm, $\angle ARG = 39^\circ$ and $\angle AGR = 58^\circ$.

c Draw $\triangle NYK$ where $NY = 5.8$ cm, $\angle KNY = \angle KYN = 75^\circ$.

d Draw $\triangle CTV$ where $CT = 5$ cm, $\angle VCT = 27^\circ$ and $\angle VTC = 115^\circ$.

3. Three Sides

Shown opposite is a rough sketch of $\triangle UVW$.

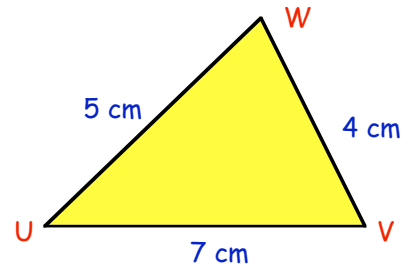

To draw it accurately :-

You will need a ruler and a pair of compasses.

Step 1 :- Draw line $UV = 7$ cm

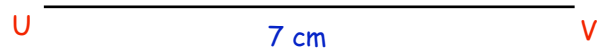

Step 2 :- Set your compasses to 4 cm, place the compass point on V and draw a light arc as shown.

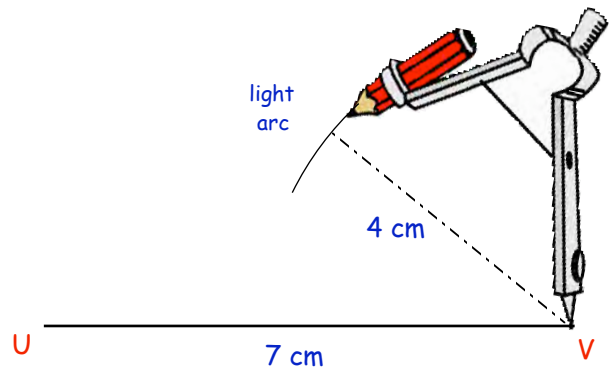

Step 3 :- Now set your compasses to 5 cm, place the compass point on U and draw a 2nd light arc.

(Call the point where the 2 arcs meet W)

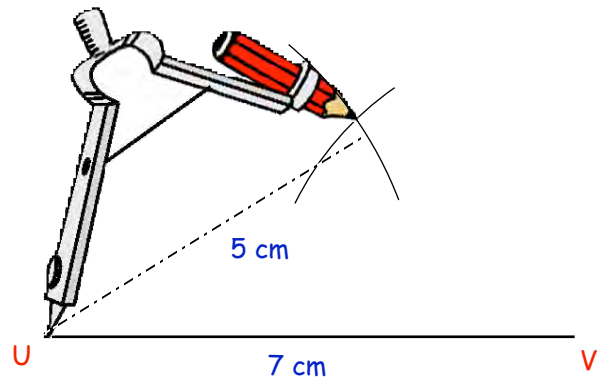

Step 4 :- Now simply use your ruler to join U to W and V to W.

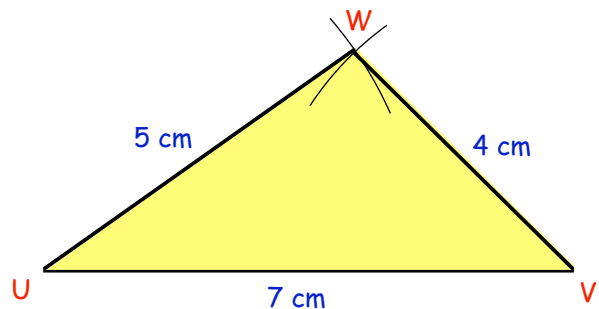

Exercise 3 (You WILL need a ruler and a pair of compasses for this exercise)

1. On the right is a rough sketch of $\triangle TYN$.

Follow the instructions to draw it **accurately** :-

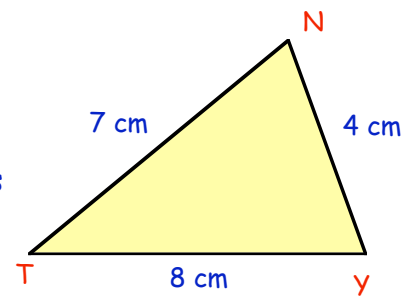

Step 1 :- Draw line $TY = 8$ cm.

Step 2 :- Set your compasses to 7 cm, place the compass point on **T** and draw a light arc.

Step 3 :- Now set your compasses to 4 cm, place the compass point on **Y** and draw a 2nd arc.

Step 4 :- Call the point where the arcs meet **N** and join **N** to **T** and to **Y**.

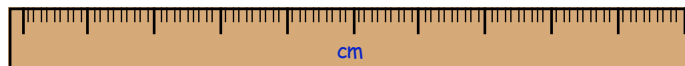

2.

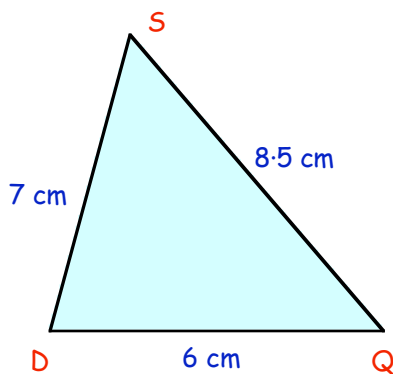

Shown is a sketch of $\triangle DQS$.

Draw it **accurately** using the following instructions :-

Step 1 :- Draw line $DQ = 6$ cm.

Step 2 :- Set your compasses to 7 cm, place the compass point on **D** and draw a light arc.

Step 3 :- Now set your compasses to 8.5 cm, place the compass point on **Q** and draw a 2nd arc.

Step 4 :- Call the point where the arcs meet **S** and join **S** to **D** and to **Q**.

3. Make **accurate** drawings of the following triangles :-

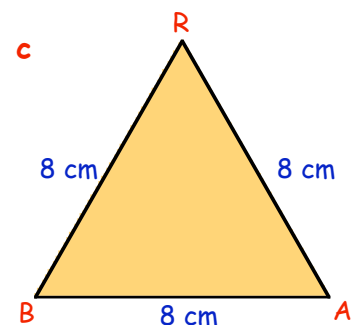
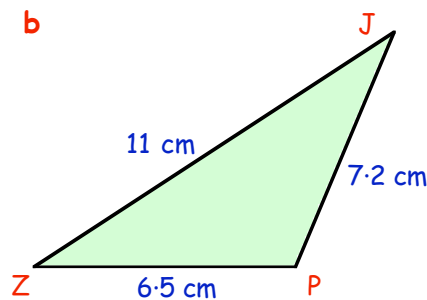
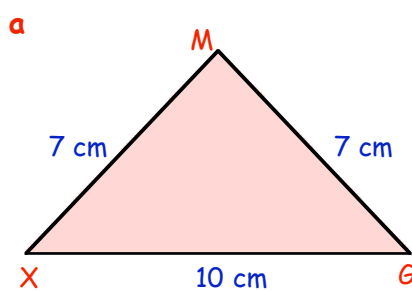

4. Make **accurate** drawings of the following triangles :-

a Draw $\triangle NQV$ where $NQ = 9$ cm, $NV = 7$ cm and $VQ = 5$ cm.

b Draw $\triangle DXR$ where $DX = 15$ cm, $DR = 9$ cm and $XR = 8$ cm.

c Draw $\triangle WHQ$ where $WH = 10.5$ cm, $WQ = HQ = 6.5$ cm.

d Draw $\triangle SKY$ where $SK = SY = KY = 8.5$ cm. (What kind of triangle is this?)

5. **Try** to draw triangle ABC with $AB = 10$ cm, $AC = 5$ cm and $BC = 4.5$ cm.

What goes wrong?

Topic in a Nutshell

You need a ruler, a protractor and a pair of compasses.

1. Draw triangle $\triangle ABC$ with
 $AB = 7 \text{ cm}$, $BC = 6 \text{ cm}$ and $\angle ABC = 70^\circ$.

2. Draw triangle $\triangle DEF$ with
 $DE = 6 \text{ cm}$, $\angle FDE = 40^\circ$ and $\angle DEF = 80^\circ$.

3. a Make an **accurate** drawing of the $\triangle PQR$ shown below.

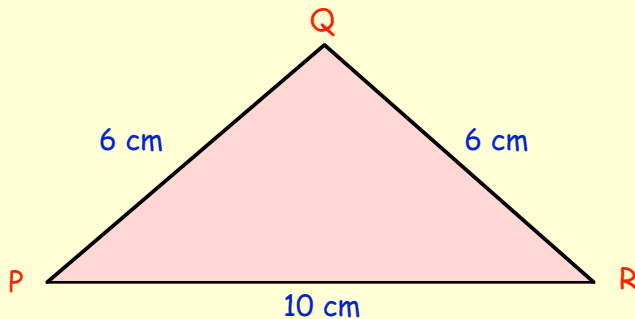

- b What kind of triangle is $\triangle PQR$?
- c Use a protractor to measure the size of each of the three angles.

4. Use a ruler and pair of compasses to draw an equilateral triangle with all three sides 6 centimetres long.

5. Use a **ruler** and **compasses** to make an accurate full size drawing of this kite as follows :-

- a Start by drawing $AC = 5$ centimetres.
- b Now draw triangle ABC , then triangle ADC using your compasses.
- c Use your protractor to measure the size of each of the 4 angles of your kite.

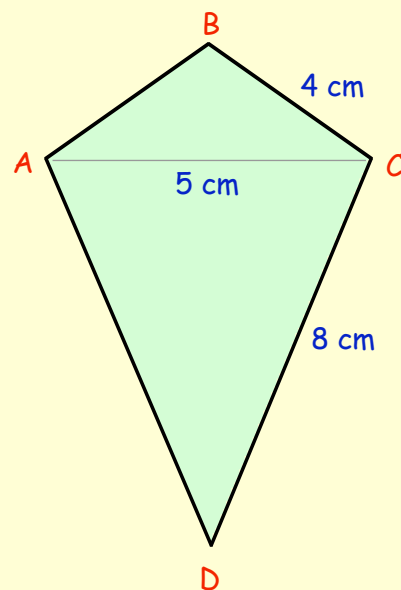

Chapter 15

Ratio

Understanding Ratio

We can use "ratios" to compare two different quantities.
 This picture shows 4 slugs and 3 snails.
 We say that "the ratio of slugs to snails" is 4 to 3.
 or for short :- slugs : snails = 4 : 3.
 (: is the symbol for ratio).

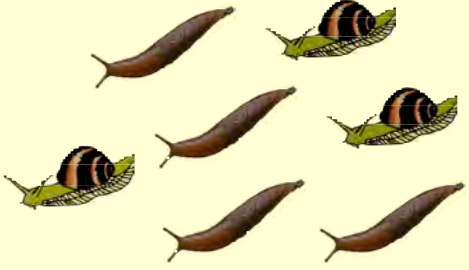

Exercise 1

1. Look at this picture. Write down the ratio :-

- a cars : buses.
- b buses : cars.



2.



- a Write down the ratio, spiders : wasps.
- b Write down the ratio, wasps : spiders.

3. In an large fish bowl there are 13 Goldfish and 17 tropical fish.

Write down the ratio of :-

- a goldfish to tropical fish.
- b tropical fish to goldfish.

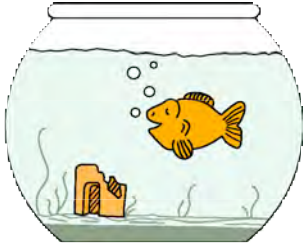

4. In a garden, there are 11 rose bushes and 5 apple trees.
 What is the ratio of :-

- a rose bushes to apple trees ?
- b apple trees to rose bushes ?

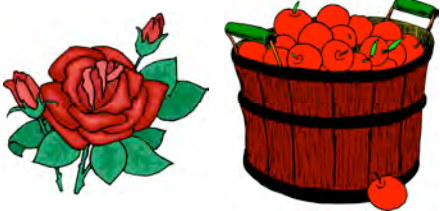

5. In her basket, Granny Smith has 2 oranges and 9 apples.
 What is the ratio of :-

- a oranges to apples ?
- b apples to oranges ?

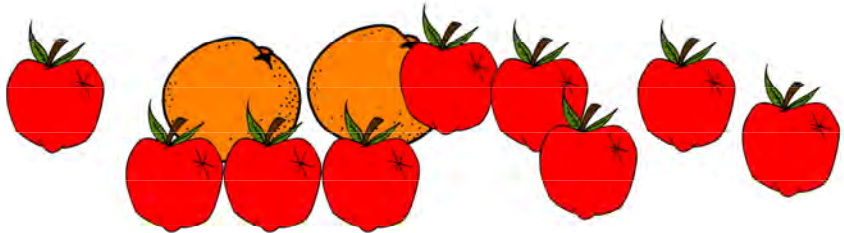

6. In a sport's shop window, there are tennis balls, rugby balls, basketballs, footballs and an ice hockey puck.

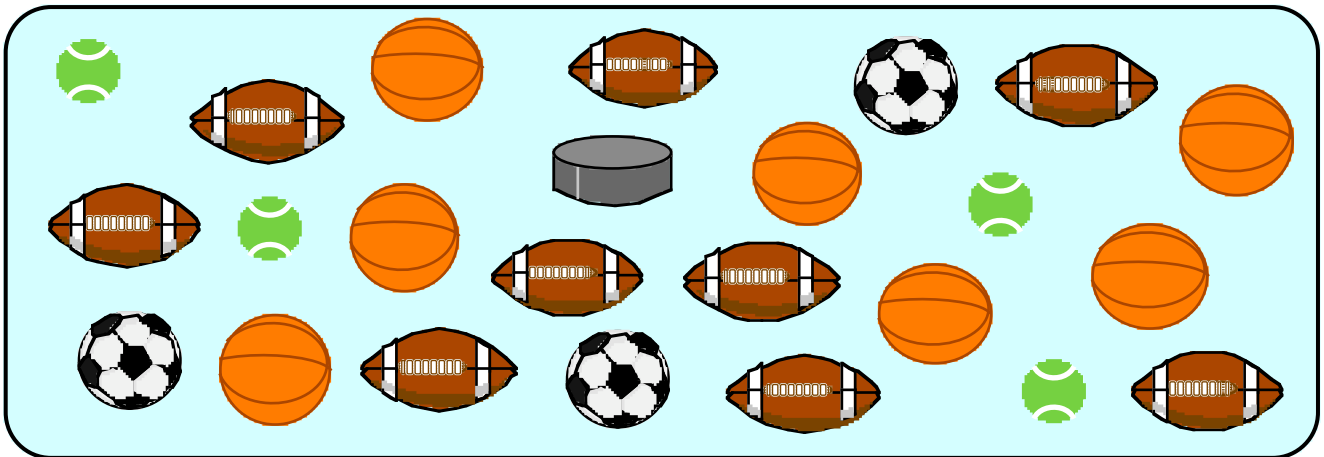

What is the ratio of :-

- a footballs : tennis balls ? b tennis balls : basketballs ?
 c rugby balls : footballs ? d tennis balls : rugby balls ?
 e footballs : basketballs ? f basketballs : tennis balls ?
 g rugby balls : ice hockey pucks ?

7. Shown is an indoor play-mat football pitch.

It is 85 cm long and 43 cm broad.

- a Write down the ratio, length : breadth.
 b Write down the ratio, breadth : length.
 c Write down the ratio, length : perimeter.

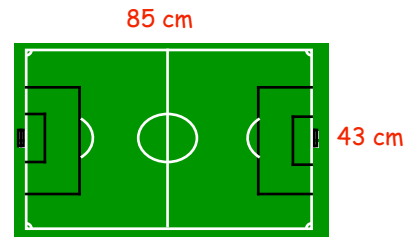

- 8.



The distance from Charley Airport to Boston Airport is 520 miles. I flew 207 miles over land and the rest of the way over the sea.

Write down :-

- a the ratio of the distance travelled by land : by sea.
 b the ratio of the distance travelled by sea : altogether.

9. Tiger has 37 golf balls of which 23 are new and the rest old.

Write down the ratio :-

- a new : total number. b new : old. c old : new.



10. During March and April, there were 19 days of recorded rainfall.

Write down the ratio of :-

- a wet days : total days.
 b wet days : dry days.



Simplifying Ratios

"Simplifying" a ratio is much the same as "simplifying" a fraction.

Remember :- $\frac{6}{8}$ can be simplified, since 6 and 8 are part of the "2 times" table.

$$\frac{6}{8} \Rightarrow \frac{6 \div 2}{8 \div 2} = \frac{3}{4}$$

Similarly, the ratio **6 : 8** simplifies to **3 : 4**.

Exercise 2

- By dividing both numbers by 2, simplify the ratio 6 : 4.
- By dividing both numbers by 7, simplify the ratio 35 : 63.
- Copy each of the following ratios and simplify each as far as possible :-

- | | | | | | | | | | | | |
|---|---------|---|---------|---|----------|---|----------------|---|---------|---|---------|
| a | 8 : 10 | b | 12 : 15 | c | 14 : 35 | d | 12 : 28 | e | 3 : 3 | f | 24 : 6 |
| g | 15 : 9 | h | 36 : 24 | i | 34 : 17 | j | 35 : 49 | k | 20 : 35 | l | 60 : 70 |
| m | 90 : 40 | n | 44 : 33 | o | 54 : 6 | p | 11 : 66 | q | 3 : 300 | r | 800 : 8 |
| s | 27 : 54 | t | 54 : 24 | u | 7 : 7000 | v | 3 : 6 000 000. | | | | |

- What is the ratio of hammers to pliers in each picture below ?

Write each ratio **in its simplest form**.

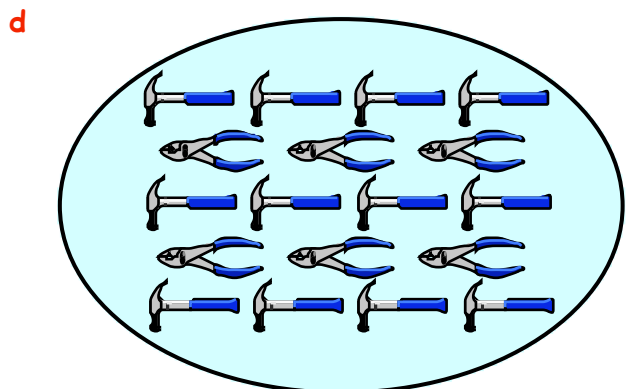
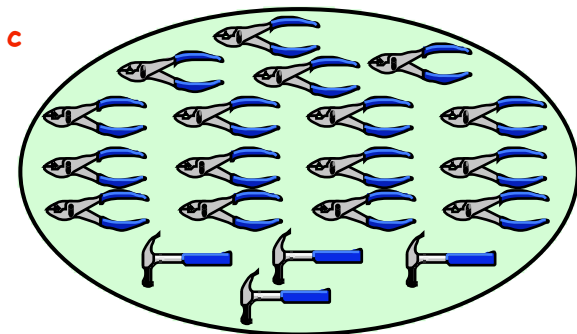
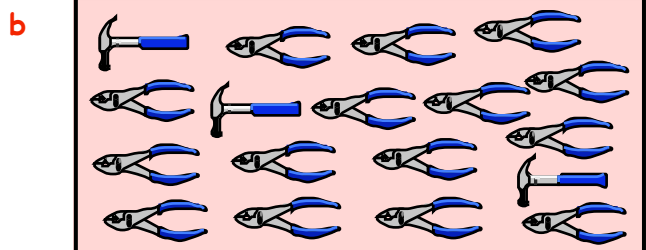
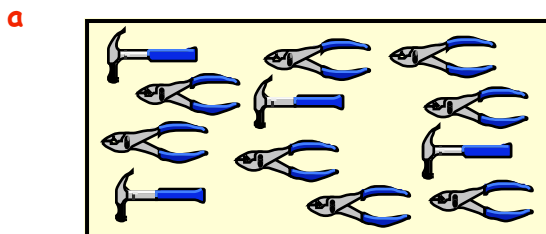

- At a rugby match there were 4 stewards for every 100 fans.

- What was the ratio of stewards to fans ?
- Give this ratio in its **simplest form**.



6. There are 15 girls and 5 boys at a dancing display.

- a Write down the ratio of girls : boys.
- b Simplify this ratio as far as possible.



7.



On a school outing, there are 27 pupils and 3 teachers.
Write, in its **simplest form**, the ratio of :-

- a pupils : teachers
- b teachers : pupils.

8. In 15 minutes, June did 210 press-ups and Gill only managed 120.

- a Write down the ratio of June's press-ups : Gill's press-ups.
- b Simplify this as far as possible.



9.



The crowd capacity of a football stadium in the city is 60000.
A smaller stadium in the city can hold up to 24000 people.

- a Write down the ratio :-
larger capacity : smaller capacity.
- b Simplify this as far as possible.

10. A surgeon charges £550 per hour for a private consultation.
A lawyer charges £330 for the same period.

- a Write down the ratio of their charges,
surgeon : lawyer.
- b Simplify this as far as possible.

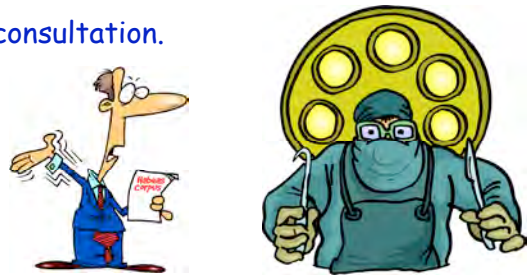

11.

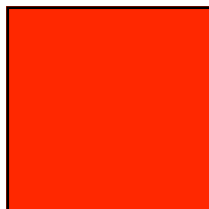
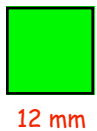

44 mm

The small square has each of its sides 12 mm long.
The larger square has its sides 44 mm long.

- a Write down the ratio of their perimeters,
small : large.
- b Simplify this as far as possible.

12. A large rectangle measures 6 m by 8 m and a smaller rectangle measures 4 m by 9 m.

- a Write down the ratio of their **AREAS**, large : small.
- b Simplify this ratio as far as possible.

13. James is 30 years old and his son Tom is 10.

- a Write down and simplify the ratio of James' age : Tom's age.
- b Write down and simplify what the ratio of their ages will be in 5 years time.
- c How old will James be when the ratio of their ages becomes 2 : 1?



14. Write each of these ratios in its **simplest form** :-

- a 1 centimetre : 1 metre b 1 metre : 1 kilometre c 30 seconds : 1 minute
 d 50 p : £3 e 1 day : 1 week f 20 centimetres : 1 metre
 g £1.50 : £6 h days in a week : days in February 2003
 i seconds in a minute : seconds in an hour.

15. Jessica earns £4.20 per hour working in ORKAM Stores and Tina earns £6.30 per hour in AEKI Stores.

- a Write down the ratio of their wages :- Jessica : Tina.
 b Simplify this as far as possible.



Ratio Calculations

Example 1 :- In a swing park one summer's evening, the ratio of girls to boys was.

$$\text{girls : boys} = 2 : 3.$$

If there were 8 girls in the park, how many boys were there ?

Set down like this :- since $8 = 4 \times 2$

$$\text{then boys} = 4 \times 3 = \underline{12}$$



girls	boys
2	3
8	12

$\times 4$ (arrow from 2 to 8) $\times 4$ (arrow from 3 to 12)

Example 2 :- To obtain a particular mixture, Bernie has to mix hardener and paste in the ratio

$$\text{hardener : paste} = 2 : 5.$$

Bernie actually uses 12 parts of hardener.
 How much paste is required ?

Set down like this :- since $12 = 6 \times 2$

$$\text{then paste} = 6 \times 5 = \underline{30}$$

hardener	paste
2	5
12	30

$\times 6$ (arrow from 2 to 12) $\times 6$ (arrow from 5 to 30)

Exercise 3

1. In a classroom the ratio of girls to boys = 1 : 2.

If there are 9 girls in the classroom, how many boys are there ?

girls	boys
1	2
9	...

$\times ?$ (arrow from 1 to 9) $\times ?$ (arrow from 2 to ...)

2. To make a glass of Cremola Foam Drink, I use 1 part powder to 5 parts water.

=> the ratio of powder to water is 1 : 5.

If I use 20 parts of powder, how many parts of water will I need ?



3. The Association of Potato Crisp Manufacturers (APCM) announced that in all leading brands the sale of plain crisps is still greater than the sale of flavoured ones.

a The sale of Vinegar Crisps to Plain Crisps is 1 : 4.
How many boxes of Plain Crisps are sold per hour in a shop if the following amount of Vinegar Crisps were sold :-

- (i) 2 boxes
- (ii) 10 boxes
- (iii) 100 boxes
- (iv) 450 boxes ?



b If the sale of Prawn Crisps to Smokey Bacon Crisps is 3 : 8, how many boxes of Smokey Bacon Crisps are sold per hour in a shop which sells the following amount of Prawn Crisps :-

- (i) 6 boxes
- (ii) 15 boxes
- (iii) 36 boxes
- (iv) 150 boxes ?

4. Many sheep farmers insist that to round up the flock, the best ratio of sheep to sheep dogs is 20 : 1.

How many sheep dogs would be required for a flock of :-

- a 40 sheep
- b 120 sheep
- c 360 sheep
- d 1000 sheep ?



5. On another evening in the swing park, the ratio of girls to boys was 3 : 4.

There were 12 girls in the park.

How many boys were there ?

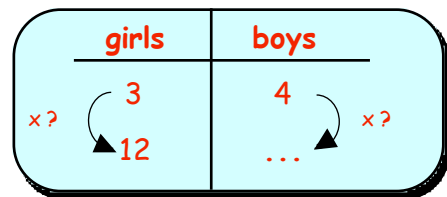

6. In a bean bag, the ratio of red beads to yellow beads is 3 : 5.

If there are 102 red beads in the bag, how many yellow beads are there ?

7. In a box of chocolate, the ratio of orange creams : caramels is 2 : 7.

If there are :-



- a 4 orange creams, how many caramels will there be ?
- b 35 caramels, how many orange creams will there be ?

8. The ratio of "Hard" questions to "Easy" questions in a National Test is 1 : 4.

a If the Test consists of 13 hard questions, how many easy ones are there ?

b If another Test consists of 28 easy questions :-

- (i) how many hard ones are there ?
- (ii) how many questions are there altogether in this test ?



9.



Bob and Joe compare the money they earn delivering newspapers.

The ratio of their weekly pay is

Bob : Joe = 5 : 8. (for every £5 Bob gets, Joe gets £8)

- a If Bob earned £45, how much must Joe have earned ?
- b If Joe earned £48, how much must Bob have earned ?

10. The field for this year's Grand National horse race was made up of black horses and "greys".

The ratio of black horses : grey horses = 6 : 5.

There were 20 greys in the race. How many black horses were there ?



11.

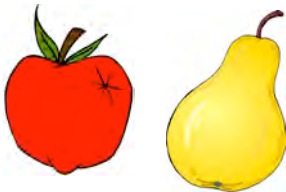

The ratio of pear trees to apple trees in an orchard is

pear : apple = 5 : 3.

- a If there are 39 apple trees, how many pear trees are there ?
- b How many trees are there in the orchard ?

12. At a school disco the ratio of pupils to teachers is 20 : 1.

If 460 pupils turn up at a disco, how many **people** in total should there be at that disco ?



13. A wizard is making his secret potion.

Which **strength** of potion does he get if he mixes :-

- a 900 grams of powder with 150 ml of liquid ?
- b 1000 grams of powder with 500 ml of liquid ?
- c 50 grams of powder with 125 ml of liquid ?
- d 600 grams of powder with 2000 ml of liquid ?
- e 1400 grams of powder with 400 ml of liquid ?

Mix in the ratio		
Strength	Hot Powder : Liquid	
Vindaloo Strong !	6	: 1
Very Strong	7	: 2
Medium Strength	2	: 1
Mild	2	: 5
Light	3	: 10

14. Andrew is making a model of a bus to a scale of 1 : 25.

- a His model is 20 cm in height. What is the height of the **real** bus, in metres ?
- b The real bus is 7.5 metres long. What length, in cm, should his **model** be ?

15. Share £9 between Simon and Garfunkel in the ratio 2 : 1 so that Simon gets the greater share.

16. Share £125 between Torvill and Dean in the ratio 3 : 2 so that Dean gets the smaller share.



Topic in a Nutshell

You need a ruler, a protractor and a pair of compasses.

1. Look at the picture.

Write down the ratio of :-

- a helicopters : jets.
- b jets : helicopters.

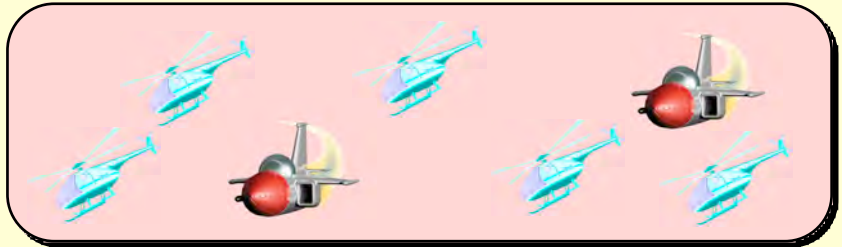

2. One day in April, the temperature in Athens was 28°C compared to 7°C in Glasgow.

- a Write the ratio of temperatures in Athens : Glasgow.

- b Give your ratio in its simplest form.

3. a In the picture, find the ratio of oranges to pears.

- b Write this ratio in its simplest form.

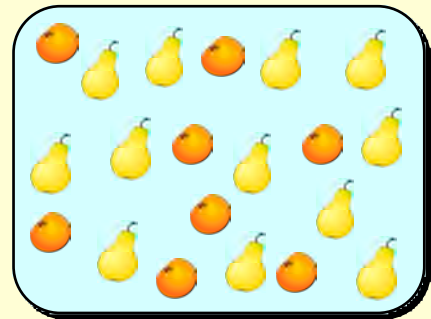

4. Kevin gets $\text{£}1.50$ pocket money per week.
Older brother Danny, gets $\text{£}4.50$.

Write the ratio of Kevin's pocket money to Danny's in the simplest form.

5. In a courtroom, the ratio of lawyers to public onlookers was 1 : 4.

If there were 5 lawyers present, how many members of the public were there ?

6. In a car park, the ratio of buses to cars is 2 : 5.

If there are 75 cars parked, how many buses are there ?

7. In an orchard, the ratio of plum trees to pear trees is 7 : 3.

- a If there are 49 plum trees in the orchard, how many pear trees are there ?
- b How many trees are there altogether in the orchard ?
- c If each tree on average bears 30 fruits, how many fruits in total will the orchard reap ?

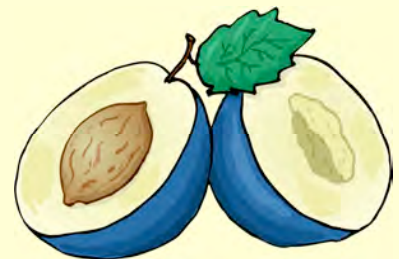

8. Write this ratio in its simplest form :-

4.5 : 0.75

Chapter 16



Volumes by Counting Cubes

The volume of a shape is simply the "amount of space" it takes up.
 One Unit of volume is the "cubic centimetre".
 The small cube shown measures 1 cm by 1 cm by 1 cm.
 It has a volume of 1 cubic centimetre.
 or for short : 1 cm^3

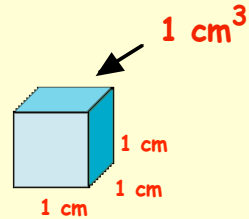

Exercise 1

1. The following shapes are made up of 1 centimetre cubes placed next to each other.
 Write their volumes in cm^3 :-

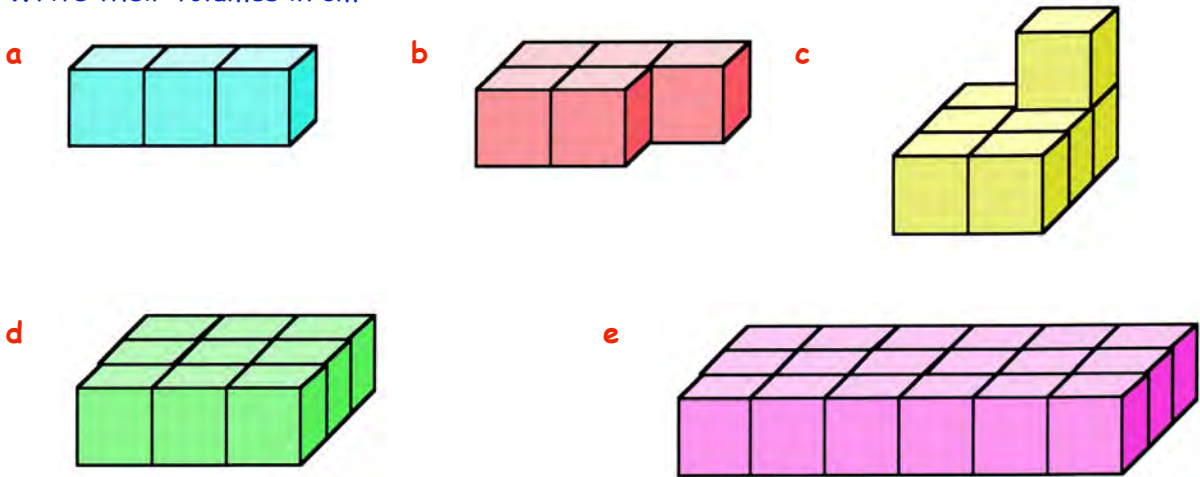

- a How many cubes are on the top layer of this shape ?
- b How many layers does it have ?
- c What is its total volume ?

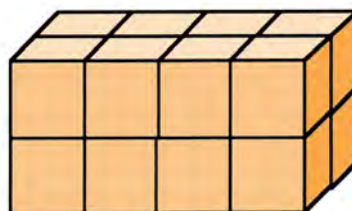

- 3. a How many cubes are on the top layer ?
- b How many layers does it have ?
- c What is its total volume ?

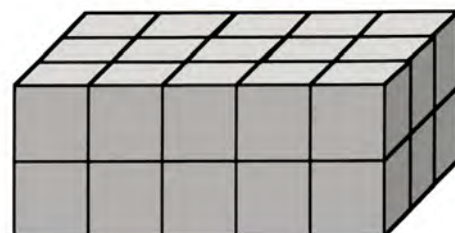

4. By working out the volume of the top layer first, calculate the total **volume** (in cm^3) of each of the following shapes :-

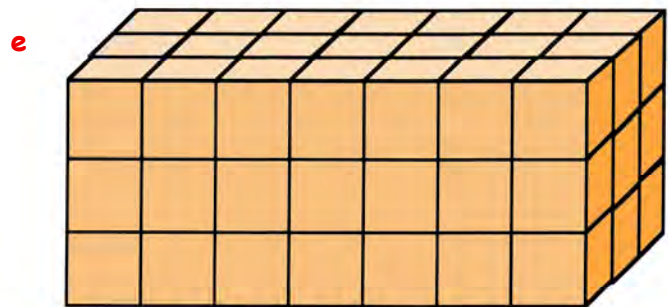
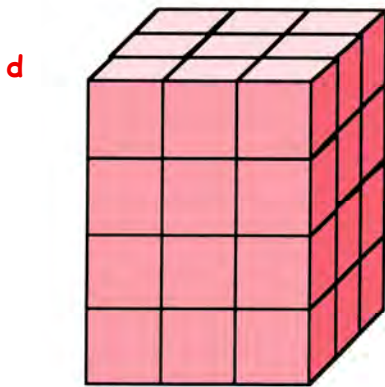
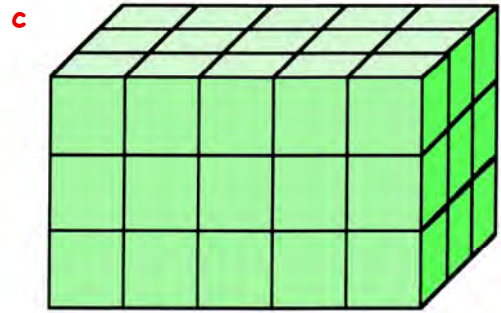
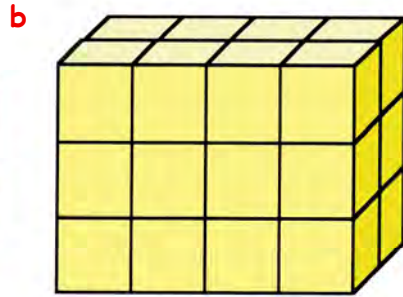
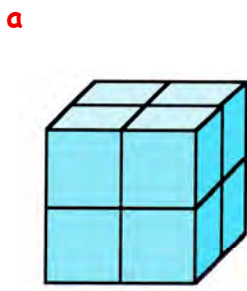

5. Calculate the **volume** of each cuboid :-
(show how you got your answers)

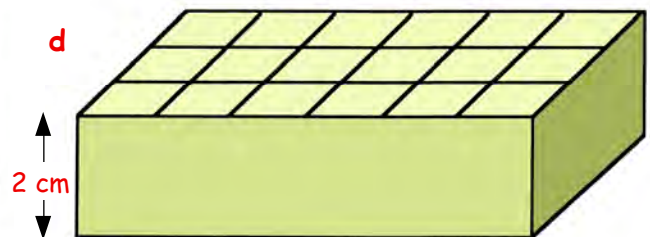
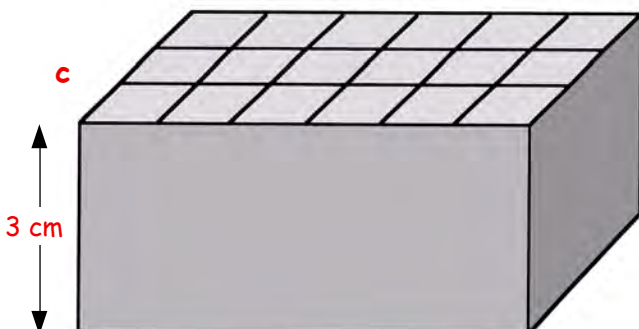
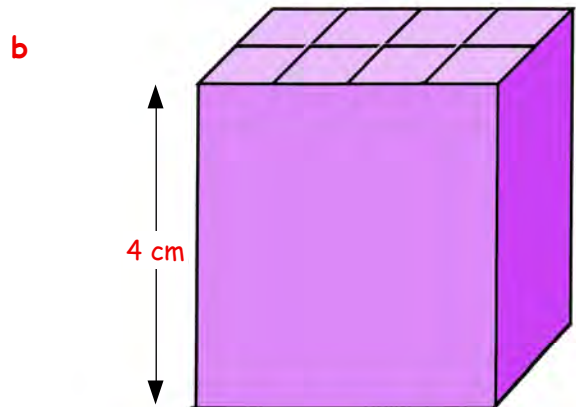
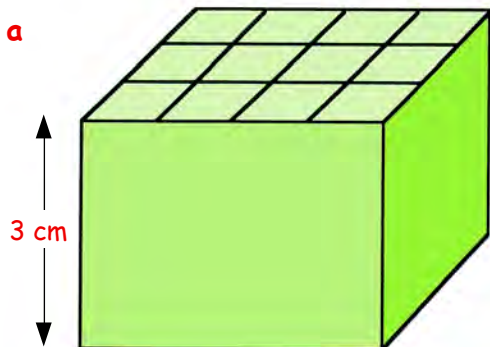

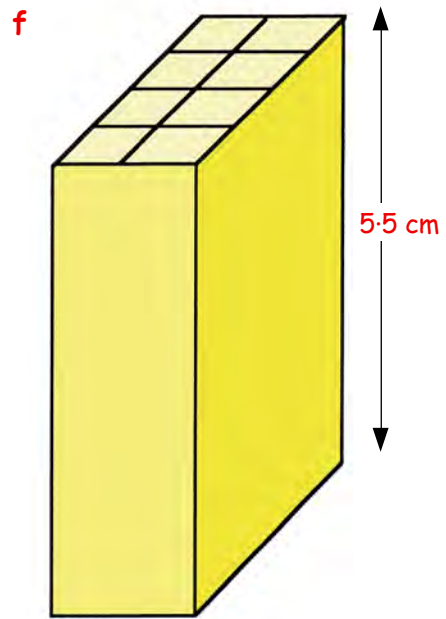
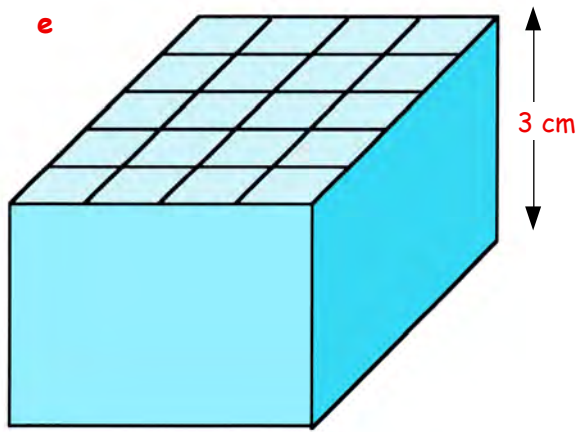

6. Calculate the **volume** of each the following shapes by counting the cubes :-

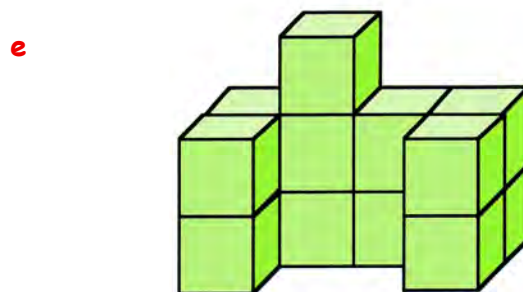
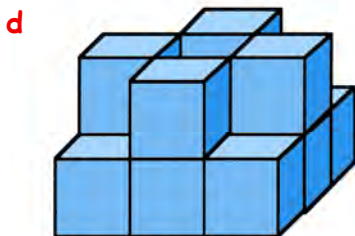
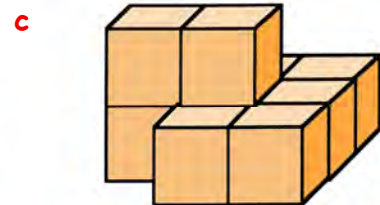
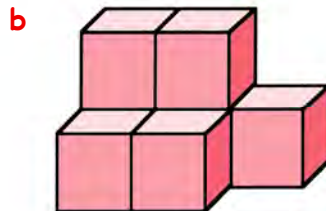
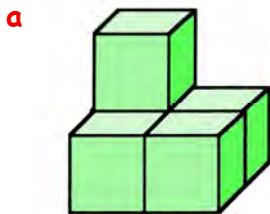

7. a Use a **ruler** and squared paper to **sketch** each of the following :-

b Write down their **volumes**.

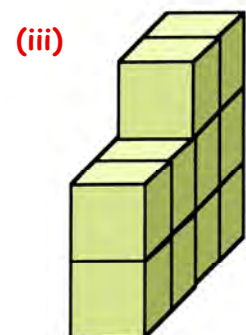
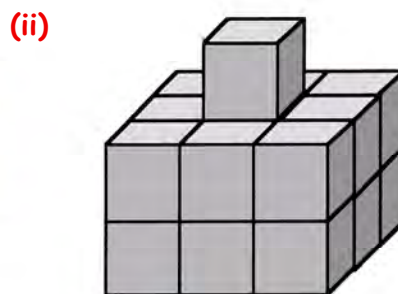
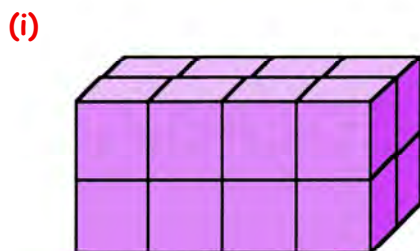

(iv)

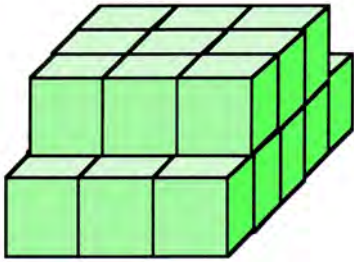

(v)

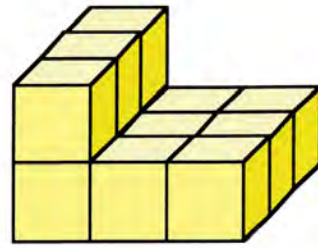

The Volume of a Cuboid - (A formula)

(i) The top layer of this cuboid is made up of $(4 \times 7) = 28 \text{ cm}^3$?

(ii) There are also 9 layers ? This means :-
Volume = $(4 \times 7) \times 9 = 252 \text{ cm}^3$?

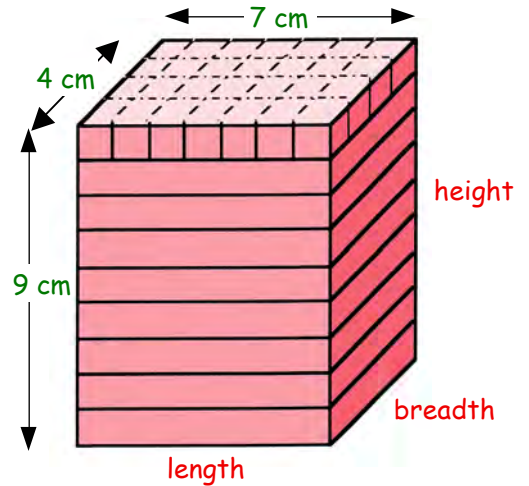

To find the volume of a cuboid, you can do so by simply multiplying

LENGTH \times BREADTH \times HEIGHT.

Formula :-

$$\text{Volume} = L \times B \times H$$

Exercise 2

1. Copy and complete for this cuboid :-



$$V = L \times B \times H$$

$$V = 7 \times 4 \times 2$$

$$V = \dots\dots\dots \text{cm}^3$$

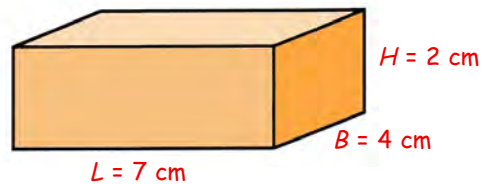

2. Use the formula $V = L \times B \times H$ to calculate the **volume** of this cuboid. (show your working).

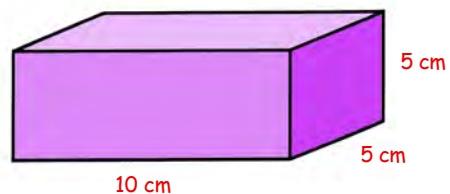

Use the formula again to calculate the **volume** of this cuboid.

4. Calculate the **volume** of each of the following cuboids (show your working) :-

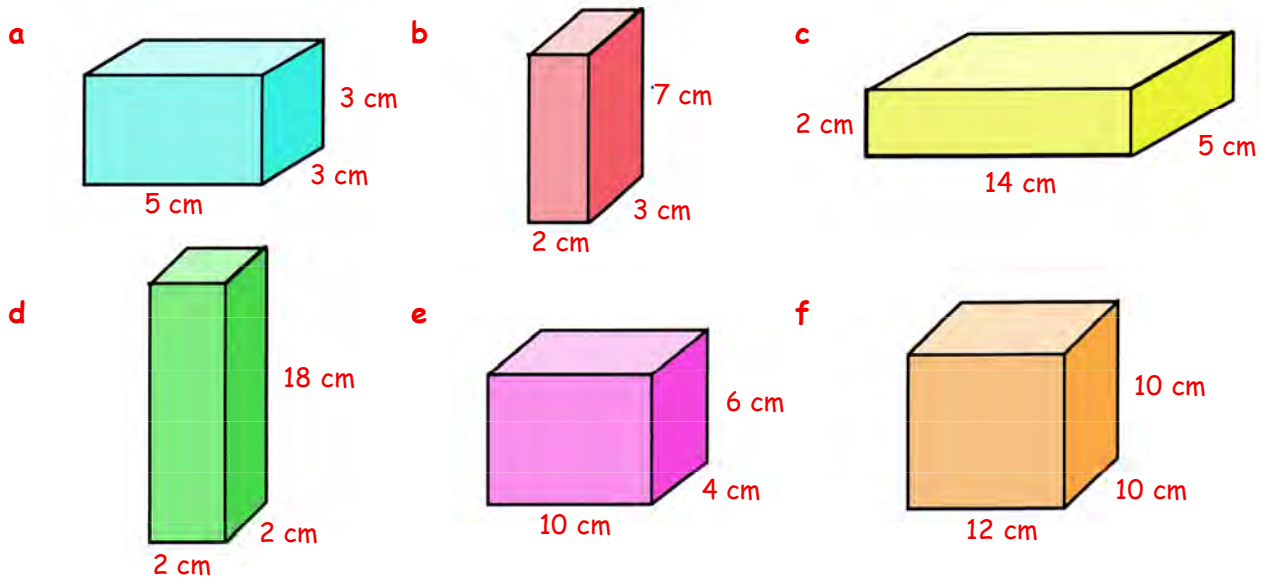

5. Calculate the **volume** of each box :-

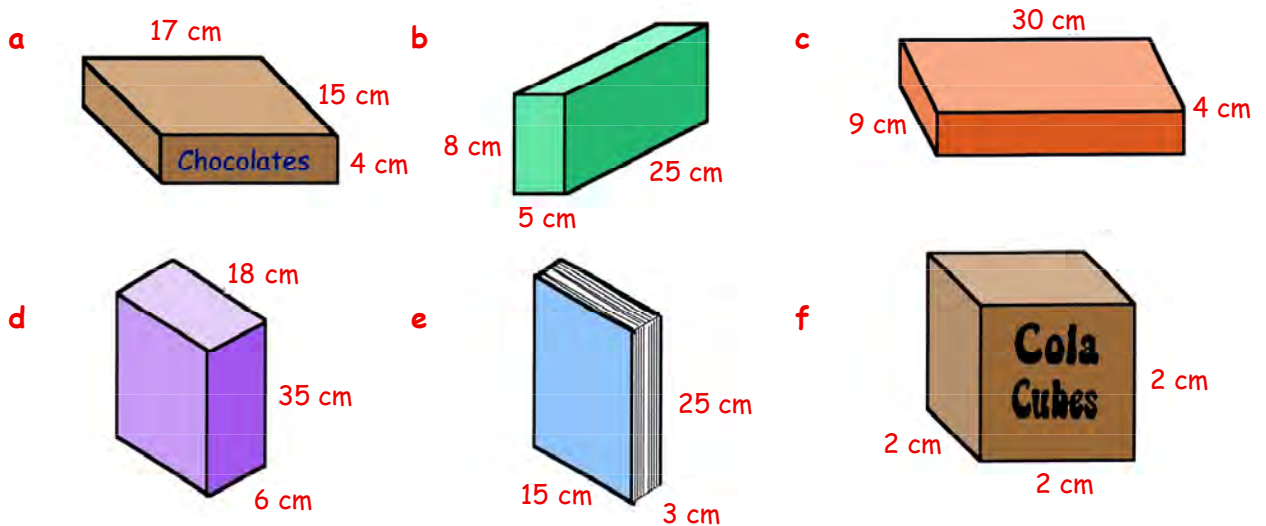

6. Calculate the **volume** of these objects, giving you answer in mm^3 , cm^3 or m^3 :-

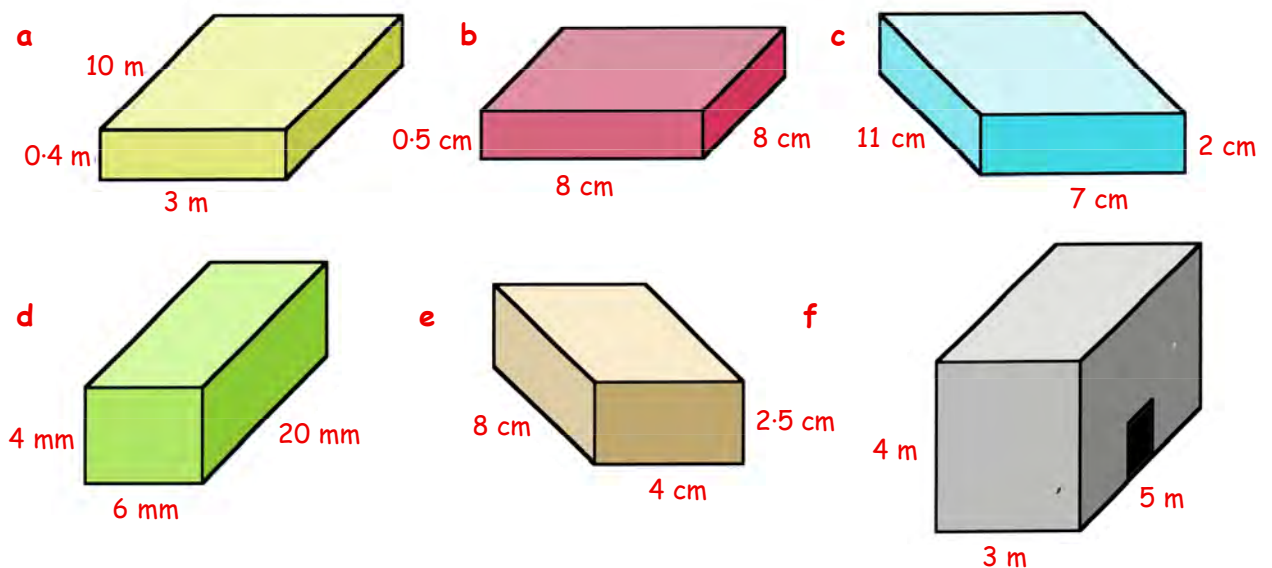

7. By calculating the **volume** of each "block" in the shape, find the **total volume** each time :-

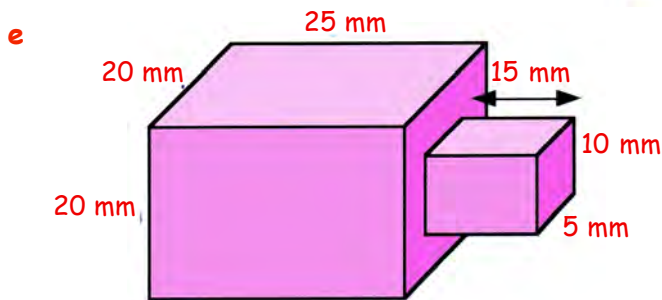
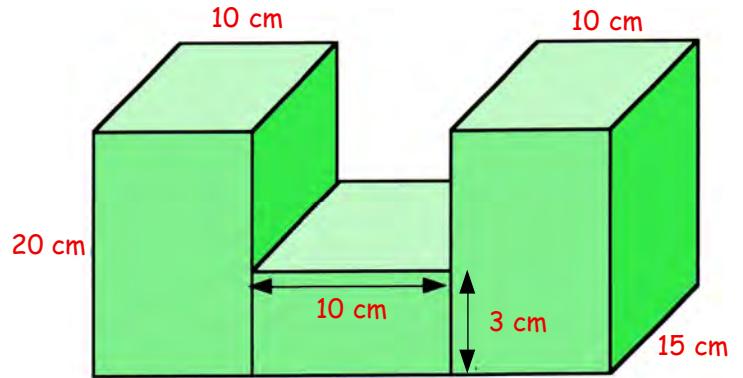
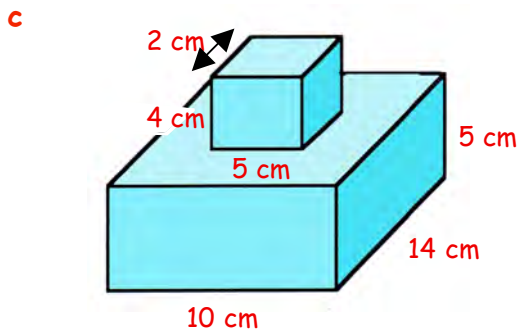
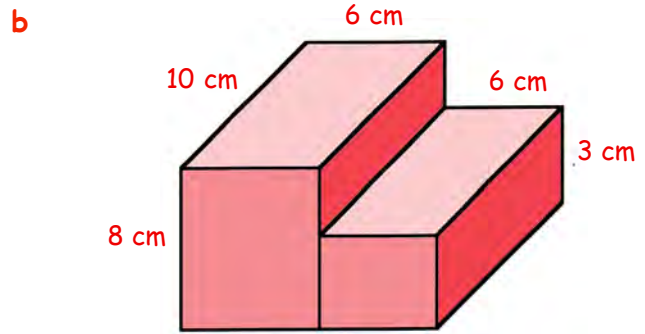
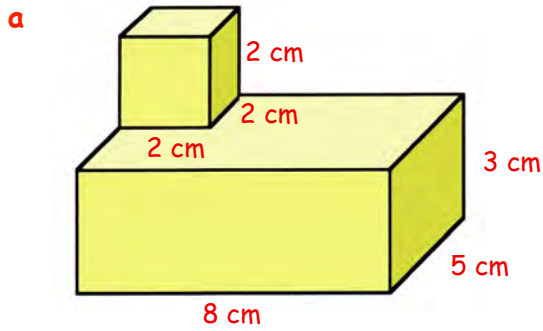

8. The **volume** of this cuboid is 60 cm^3 .
Calculate its **height**.

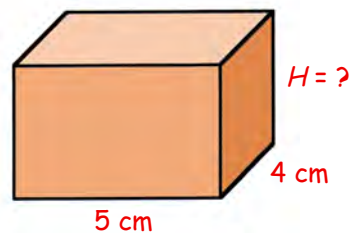

9. Calculate the length of the missing edge in each of the following cuboids :-

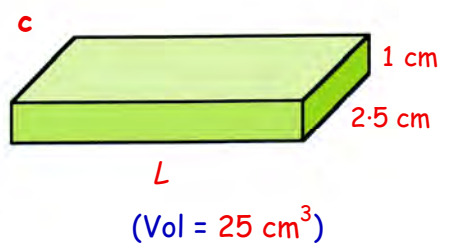
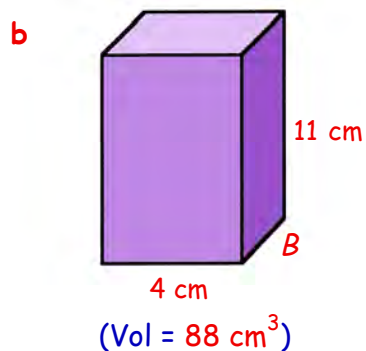
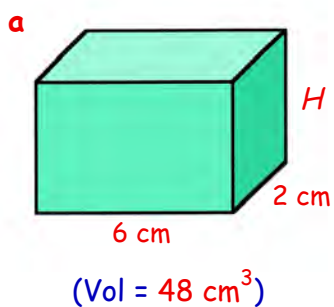

Liquid Volumes

If you take a **hollow cube** whose sides are all 1 centimetre, and fill it with water, we say it holds 1 **millilitre** of liquid.

$$1 \text{ cm}^3 = 1 \text{ ml}$$

$$1000 \text{ cm}^3 = 1000 \text{ ml} = 1 \text{ litre}$$

$$\text{Volume} = 1 \text{ cm}^3 = 1 \text{ ml}$$

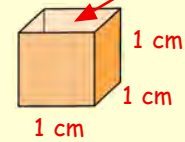

Exercise 3

1. a Calculate the volume of this rectangular container, in cm^3 .
b How many millilitres of liquid will it hold ?

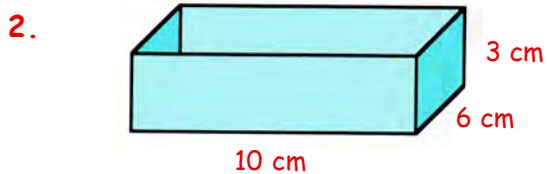
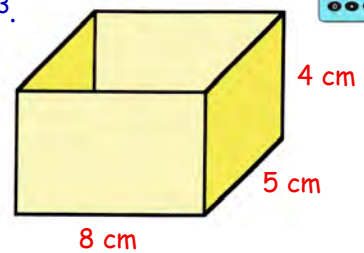

- a Calculate the volume of this rectangular container, in cm^3 .
b How many millilitres of liquid will it hold ?

3. Calculate how many millilitres of liquid each of these containers will hold :-

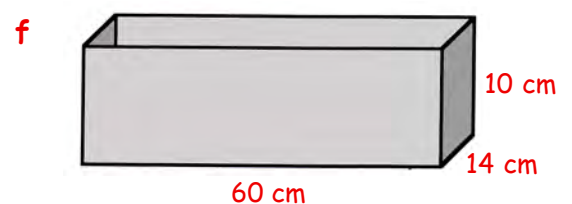
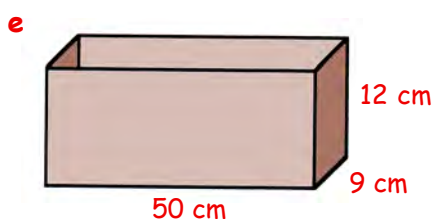
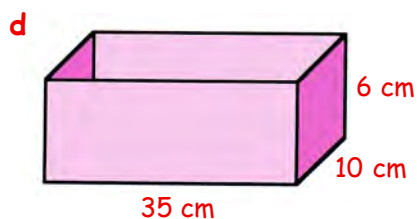
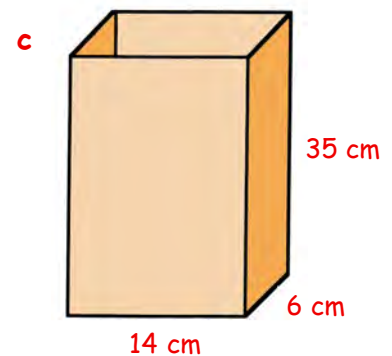
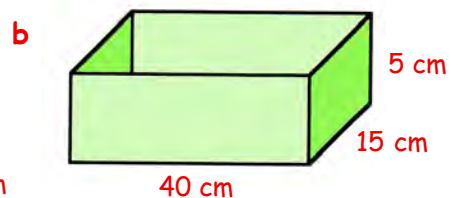
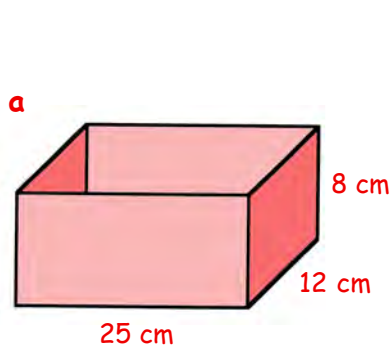

4.

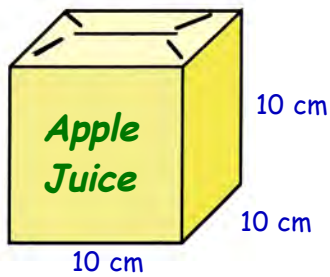

A new fruit juice carton is designed.
It is a cube measuring :-

10 cm by 10 cm by 10 cm.

- Calculate its **volume** in cm^3 .
- Write down its volume in **millilitres**.
- How many **litres** will it hold ?

5. **Remember :- to change from millilitres \rightarrow litres you simply \div 1000.**

Change each of the following to litres :-

- | | | |
|-----------|-----------|-------------|
| a 4000 ml | b 7000 ml | c 18 000 ml |
| d 6500 ml | e 1300 ml | f 12 450 ml |
| g 400 ml | h 200 ml | i 750 ml |

6. Calculate how many litres of liquid each of the following containers could hold :-

(hint : use $V = L \times B \times H$ to find the answer in $\text{cm}^3 \rightarrow \text{ml} \rightarrow \text{litres}$)

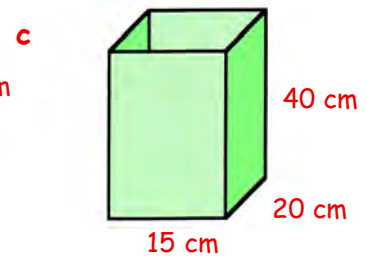
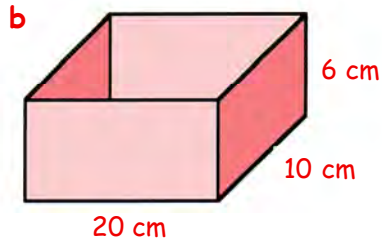
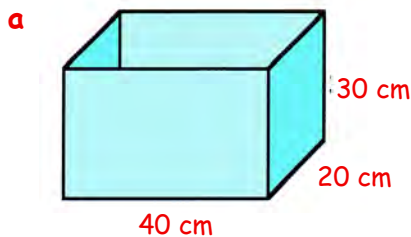

7. A container, in the shape of a cuboid, holds salt.

- Calculate its **volume** in cm^3 .
- How many litres can it hold ?
- How many 4 litre packets can be filled from the box when it is full ?

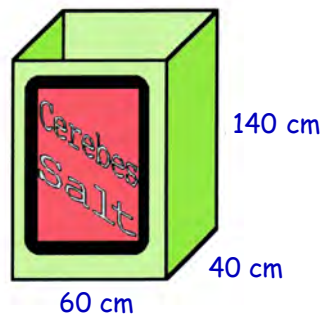

8. This box holds sand or water for children to play with.

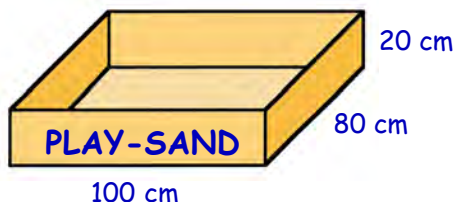

- Calculate its **volume** in cm^3 .
- How many millilitres will it hold when full ?
- Write its volume in litres.

9. This tank holds 30 litres of oil.
It's base measures 50 cm by 30 cm.
Calculate its **height**.

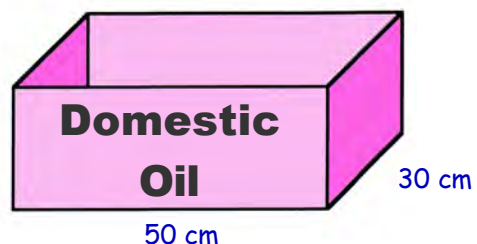

10. Blocks of concrete are measured in cubic metres.

The diagram shows 1 m^3

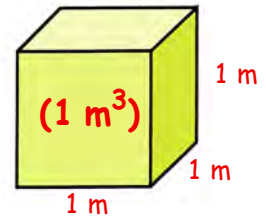

Calculate the **volumes** of the following concrete blocks (in m^3).

a

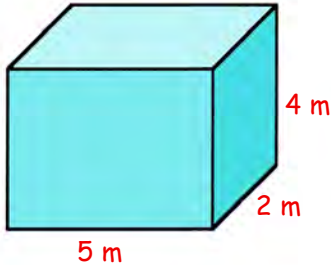

b

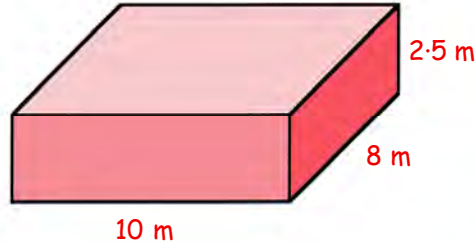

c

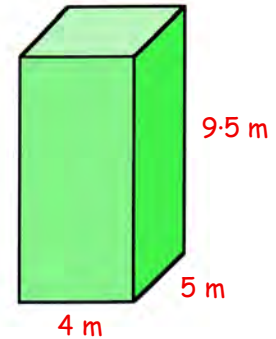

11. A carton of soup is in the shape of a cuboid measuring 20 cm by 40 cm by 10 cm.

a Calculate its **volume** in cm^3 .

b How many litres can it hold?

The carton is poured into a catering container.

c Calculate the **volume** of the container in cm^3 .

d How many litres can the container hold?

e How many times must the carton be used to fill the container?



12.

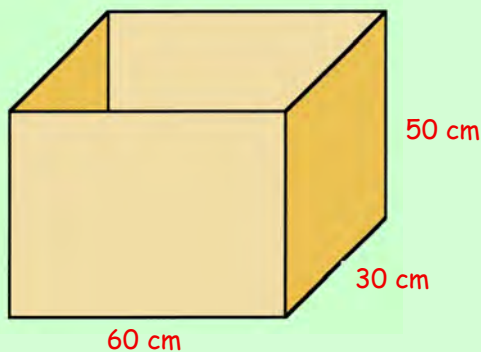

Calculate how many **litres** of water this tank can hold if it is :-

a full

b $\frac{1}{2}$ full

c $\frac{1}{5}$ full

d $\frac{3}{10}$ full?

13. This tank is full of diesel oil.

a Calculate its **volume** in cm^3 .

b How many litres can it hold?

When the tap is opened the oil pours out at a rate of 5 litres/minute.

c How long will it take for the tank to empty?

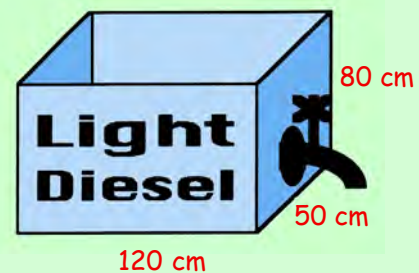

Topic in a Nutshell

1. Work out the **volumes** (in cm^3) of the following shapes :-

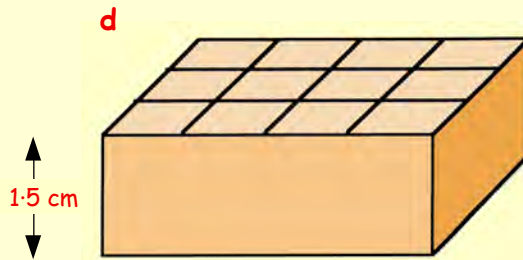
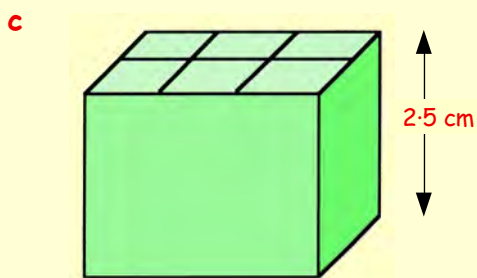
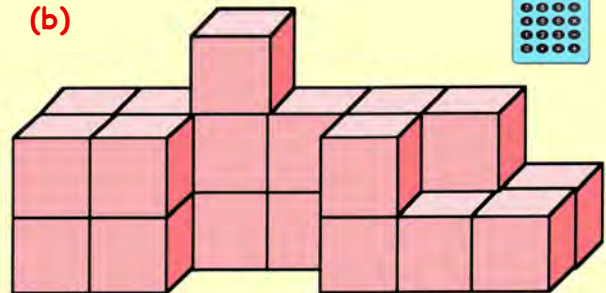
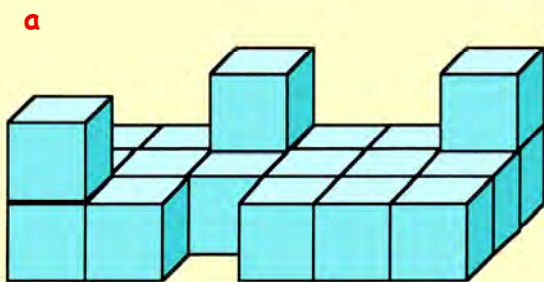

2. Use the formula you have learned to find the **volume** of each of the following cuboids :-
(Remember the units)

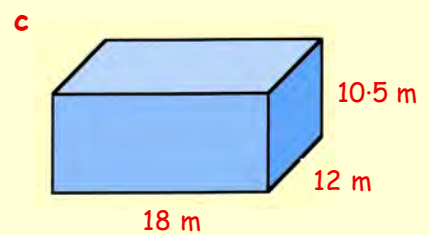
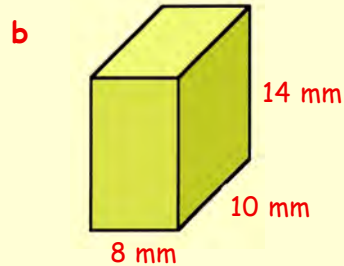
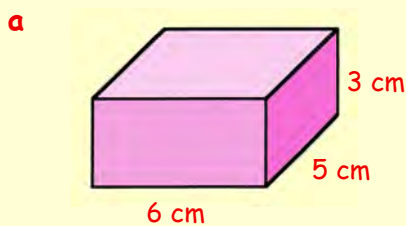

3. Find the length of the missing edge in this cuboid.



4. Calculate the **total volume** of this shape.

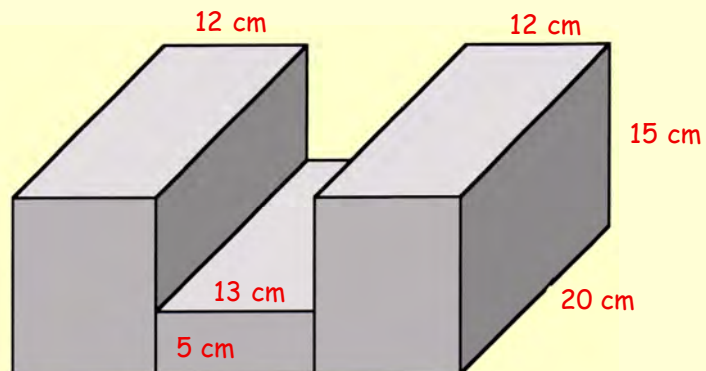

5. a Calculate the volume of this rectangular tank (in cm^3).

b How many millilitres of liquid will it hold ?

c How many litres is this ?

d How many 12 litre drums can be filled from this container ?

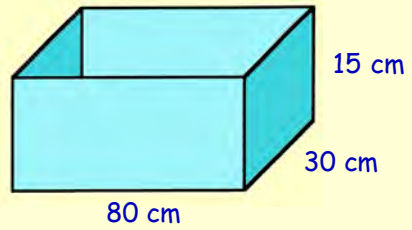

6.

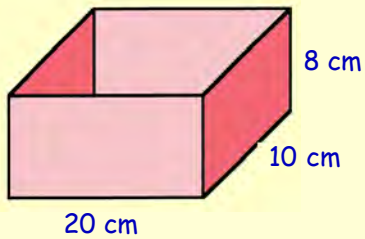

Calculate how many litres this rectangular tank can hold when it is :-

a full b $\frac{1}{2}$ full c $\frac{7}{10}$ full ?

7. A farmer turns a tap on in order to fill this drinking trough with water.

The water pours into it at a rate of 5 litres per minute.

He thinks he can fill the trough in under an hour.

Can he ?

(you must show all your working)

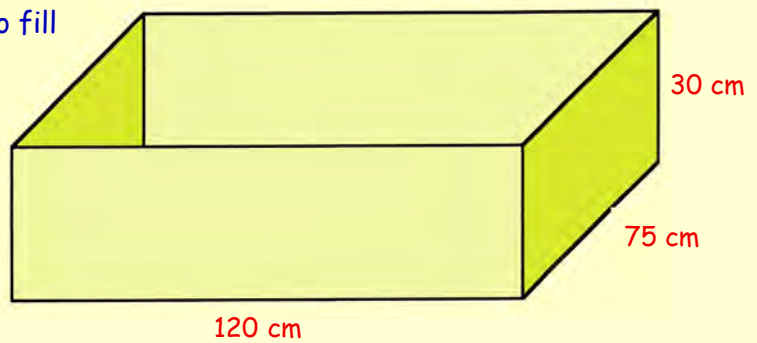

8. Look at this pattern made of cubes.



Pattern 1

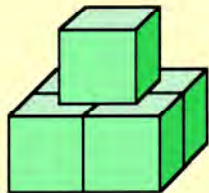

Pattern 2

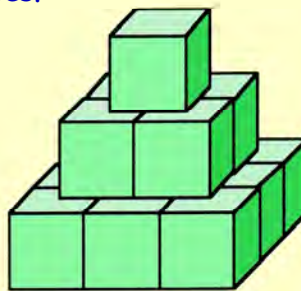

Pattern 3

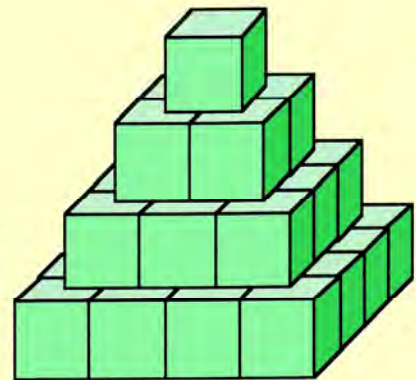

Pattern 4

a How many cubes are there in pattern number :- (i) 1 (ii) 2 (iii) 3 (iv) 4 ?

b How many cubes will there be in pattern number 5 ?

c How many will there be in pattern number 10 ?

Chapter 17

Scale Drawing

Using Scales :-

The map shows Flaherty Island

It has been drawn to a scale of

$$1 \text{ cm} = 5 \text{ km.}$$

What this simply means is that every time you measure **1 centimetre** on the diagram, in **real life** it represents **5 kilometres**.

If you measure the distance from Maleigh to Slough on the map, you will find it is **4 centimetres**.

$$\Rightarrow \text{the real distance between the 2 towns is} = 4 \times 5 = 20 \text{ kilometres}$$

RULE :- If you wish to find the **REAL** distance between 2 places :-

- **Measure** the distance on the map using a ruler,
- **Multiply** your measurement by the "scale" value.

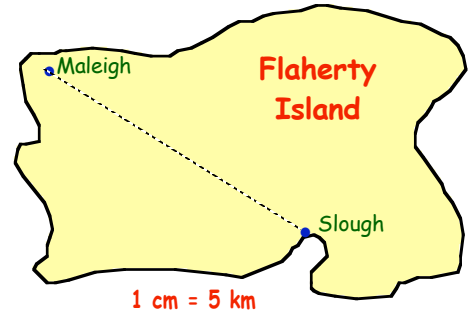

Exercise 1 (You **WILL** need a **ruler** and a **calculator** for this exercise).

1. This scale drawing of The Lacorna Dancehall floor is drawn to a scale of :-

$$1 \text{ cm} = 4 \text{ m.}$$

- Measure the length and breadth of the hall.
- Now calculate the **REAL** length and breadth of the Lacorna.



2. This truck has been drawn using a scale :-

$$1 \text{ cm} = 1.5 \text{ m.}$$

- Measure the height of the lorry.
- Calculate the **real** height of the truck in metres.
- Calculate the real length of the truck.



3.



The Norwegian flag is drawn to a scale of :-

$$1 \text{ cm} = 40 \text{ cm.}$$

- Calculate the real height of the flag.
- Calculate the real width of the flag.

4. A rectangular plot of shrubland is cleared in order to build houses on it.

The scale is :- $1\text{ cm} = 25\text{ metres}$.

- Measure the length and breadth of the plot of land.
- Calculate the real length and the real breadth of the plot of land.
- Calculate the **perimeter** of the plot.

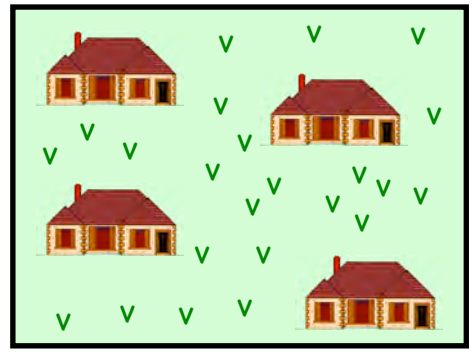

5. This bed has been drawn to a scale :-

$1\text{ cm} = 30\text{ cm}$.

- Measure the length of the bed
- Calculate the real length of the bed.
Give your answer in metres (as a decimal).
- Calculate the **real** width of the bed.

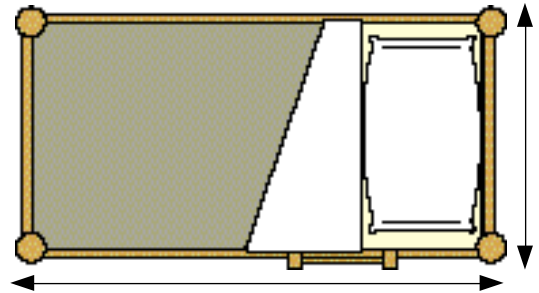

6. This old steam train and coal wagon has been drawn to a scale of :-

$1\text{ cm} = 80\text{ cm}$.



- By measuring the length of the train and wagon, and using the given scale, calculate the **real** length of the steam train and wagon (in metres).
- Calculate the height of the steam train.

7. This lighthouse has been drawn to a scale of :-

$1\text{ cm} = 5\text{ metres}$.

- Measure the height of the lighthouse.
- Calculate the **real** height.

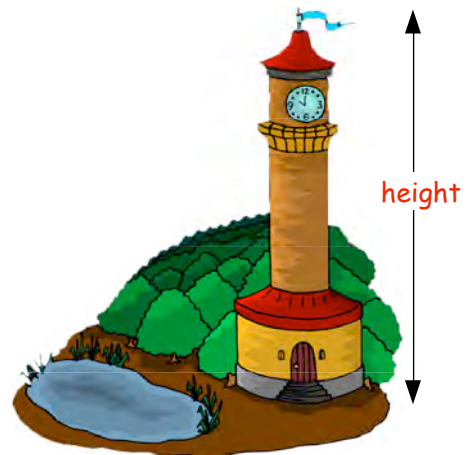

8. Shown is a scale drawing of a scout hall

The scale is :- $1 \text{ cm} = 4 \text{ m}$.

- Measure the length and breadth of the scout hall.
- What is the **real** length and breadth of the hall in metres.
- Jim enters by the door and walks to the window. How many metres has Jim walked ?

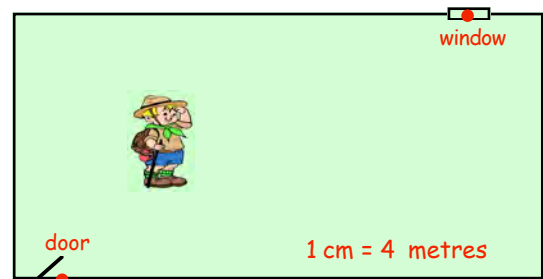

9. The map opposite shows 4 towns on part of the mainland :-

- Use your ruler to measure the distance from Brum to Aaron.
- Use the scale of the map to determine the **real** distance between the 2 towns.
- Measure the distance between the following pairs of towns and then use the given scale to calculate the real distance between them :-
 - Brum and Chrichton.
 - Aaron and Daville.

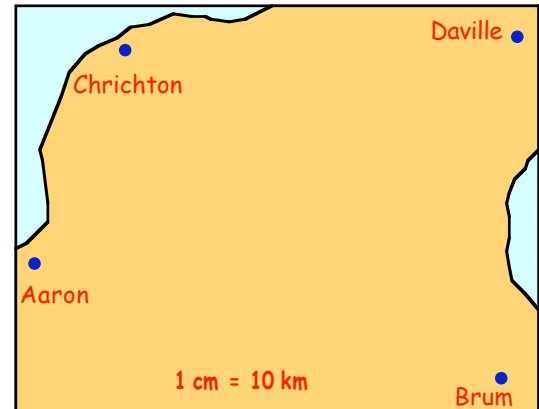

10.

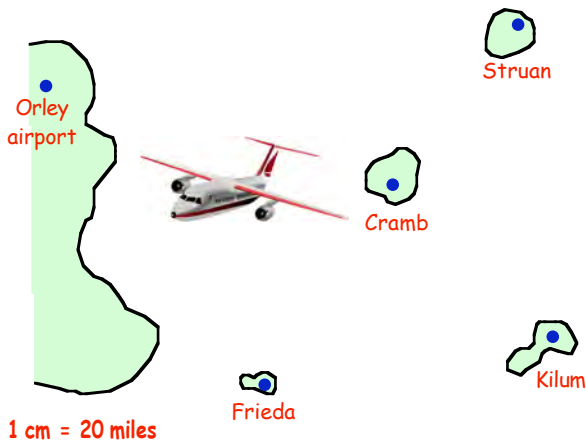

The pilot of a light aircraft earns a living delivering mail to and around a group of islands.

The dots show the airport and the landing strips.

- Measure the distance from Orley to Struan.
- Use the scale ($1 \text{ cm} = 20 \text{ miles}$) to calculate the real distance from Orley to Struan.
- Calculate the **real** distances from Orley to :-
 - Cramb
 - Kilum
 - Frieda.
- The pilot flies from Orley to Struan, then to Cramb, Kilum and Frieda before returning to Orley. How far has he flown altogether ?

11. Rams Hatch Motorcycle racing circuit is shown opposite.

The longest "straight" is from A to B.

- Measure the distance from A to B.
- Calculate the **real** distance from A to B.
- By measuring the total length of the circuit in centimetres, calculate the **real** distance, giving your answer in kilometres.

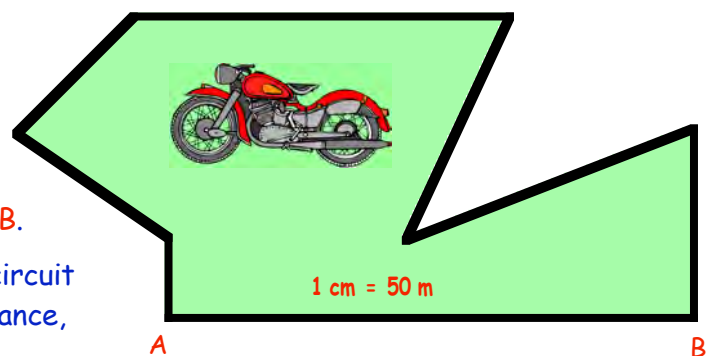

Making a Scale Drawing

Use a ruler in this exercise - make sure your drawings are done **neatly**.



Exercise 2

1. This is a sketch of a rectangular living room.
Make an accurate scale drawing of the room using a scale of :-

1 cm = 1 metre.



- 2.

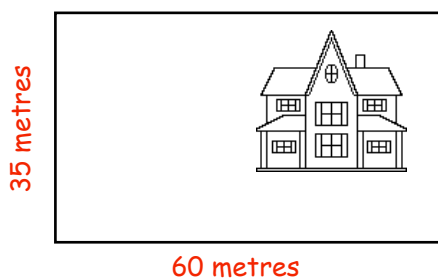

This is a sketch of school's playground.

Follow the instructions below on how to make an accurate scale drawing of it using a scale :-

1 cm = 5 metres.

- a If 5 metres is represented by 1 centimetre in the scale drawing,
=> 60 metres (length) will be represented by $(60 \div 5) = 12$ cm.
Begin by drawing a line 12 centimetres long.
- b Next, 35 metres (breadth) will be represented by $(35 \div 5) = \dots$ cm.
Now complete your scale drawing by drawing the width ... centimetres long and completing the rectangle.

3. The rectangular frame in this advert measures 110 centimetres by 80 centimetres.
Make a scale drawing of the window frame using a scale :-

1 cm represents 20 cm.

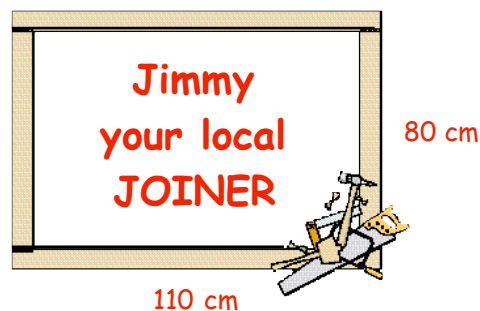

4. Shown is a rectangular plot of park land.

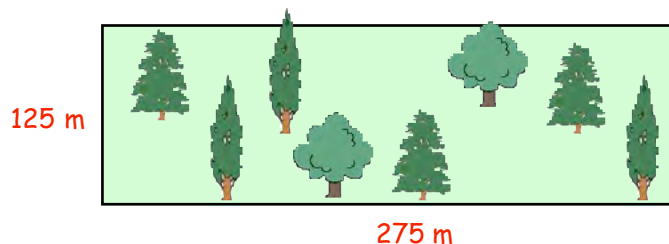

Make a scale drawing of the land using a scale :-

1 cm = 25 m.

5. In a boat race, a yacht sails along a triangular course as shown.

a Make a neat scale drawing of the triangular route :-

1 cm = 100 metres.

b Measure the length of the 3rd leg of the race on your drawing and use the scale to calculate the **real** length of the third leg in metres.

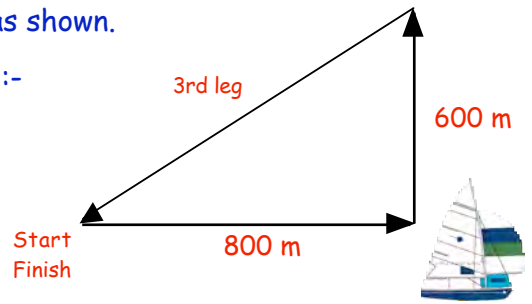

6.

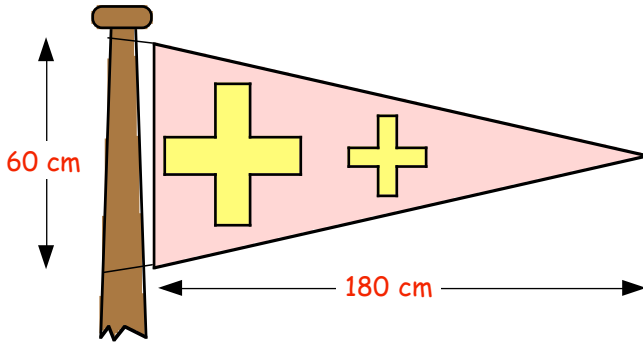

This triangular flag measures 180 centimetres by 60 centimetres.

Make a scale drawing of the flag.

Scale :- **1 cm = 12 cm.**

7. This "L-Shaped" garden is 23 metres long and 12 metres wide.

Make a neat scale drawing of the garden (not the house) using a scale of :-

1 cm = 2 metres.

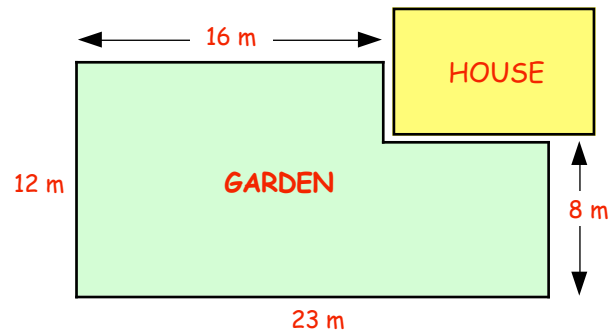

8.

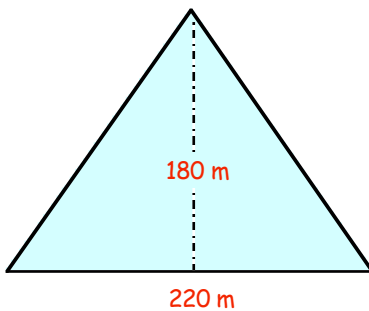

Shown is the triangular side wall of an Egyptian Pyramid.

The base of the pyramid is 220 metres long and the "height" of the triangular face is 80 metres.

Make a scale drawing of the pyramid wall face.

Scale :- **1 cm = 20 metres.**



9. This sketch shows the side view of a house.

a Make a scale drawing of it using a scale of :-

1 cm represents 50 cm.

b Measure the length of the sloping roof in centimetres and calculate the **real** length of the sloping roof.

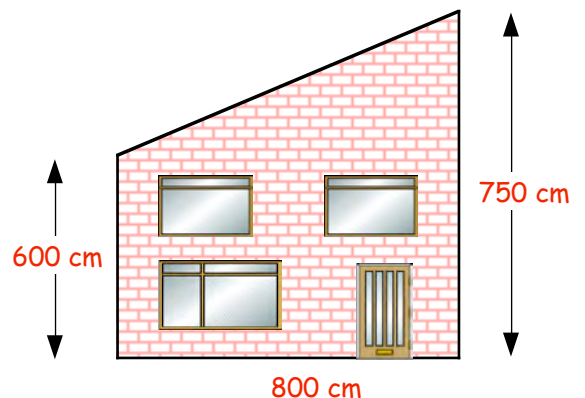

2. a Make a scale drawing to show the height of this house viewed from point X.

scale :- $1\text{ cm} = 3\text{ metres}$.

- start by drawing the line representing XY.
- draw a feint line straight up from Y.
- use your protractor to show $\angle\text{TXY} = 28^\circ$.
- complete the drawing.

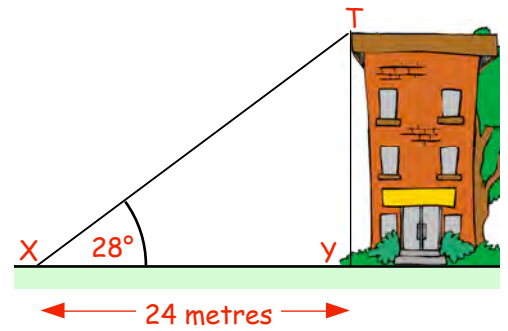

- b Measure, in centimetres, the height of the house in your drawing.
 c Calculate the height of the **real** house.

3. A man takes part in a "rope slide" to raise money for charity.

The wire rope is attached from a cliff-top to a boat waiting in the sea below.

The angle of elevation of the top of the cliff from the boat is 43° .

- a Make a scale drawing of the boat and the cliff.

scale :- $1\text{ cm} = 10\text{ metres}$.

- b Calculate the **real** height of the cliff.

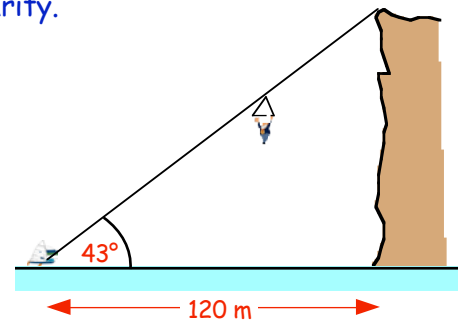

4. For each of the following,

- (i) Make a scale drawing using the given scale.
 (ii) Calculate the **real** height of the given object.

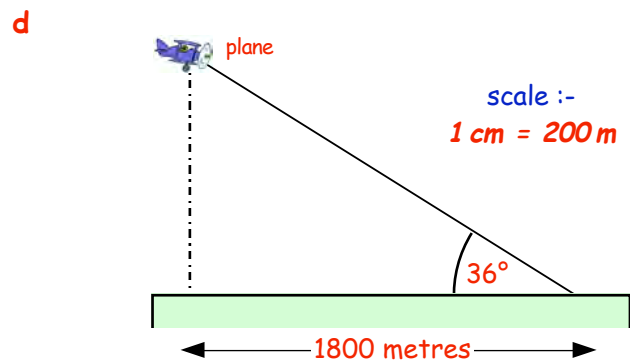
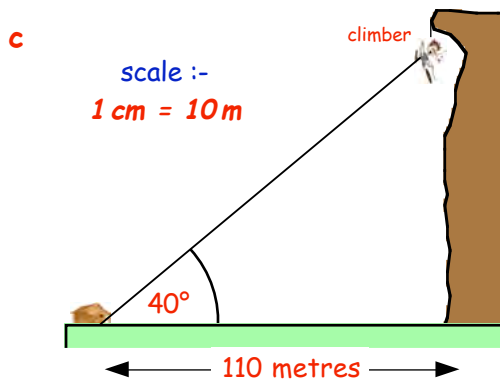
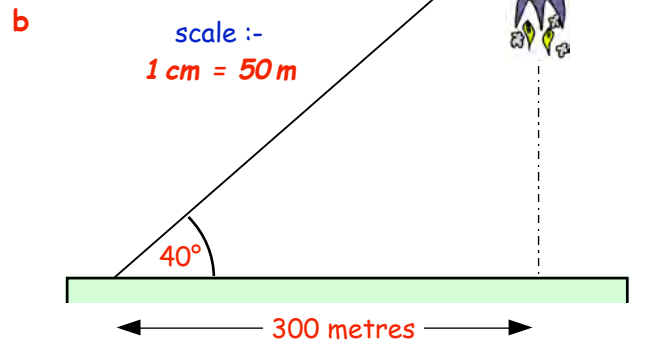
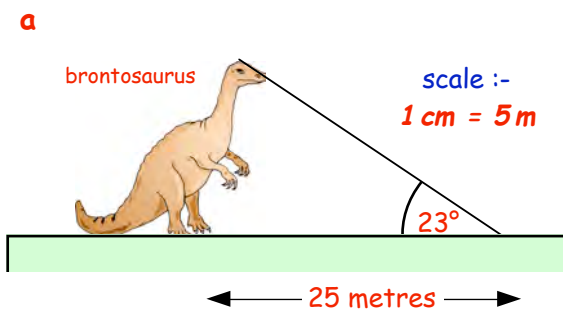

5. The picture shows George Washington, as a boy, chopping down the famous cherry tree.

a Draw a triangle using the scale

$$1 \text{ cm} = 40 \text{ cm.}$$

b Measure the height of the tree in your figure and calculate the height of the **real** tree.

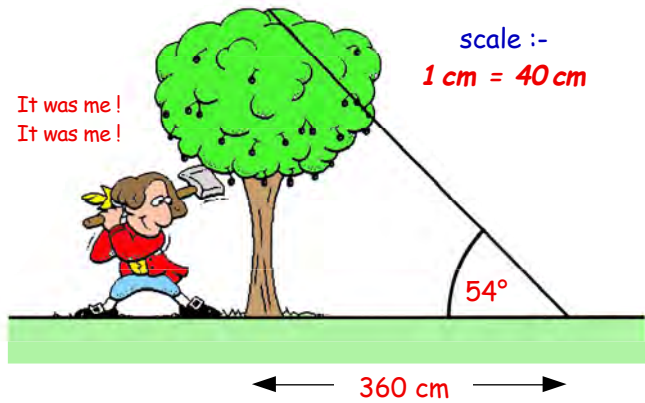

6. Shown is the front view of St Stephen's church in the village of Brimley.

a Make a scale drawing to represent the height of the steeple using a scale

$$1 \text{ cm} = 3 \text{ m.}$$

b Measure the height of the steeple in your scale drawing and calculate the **real** height of the steeple.

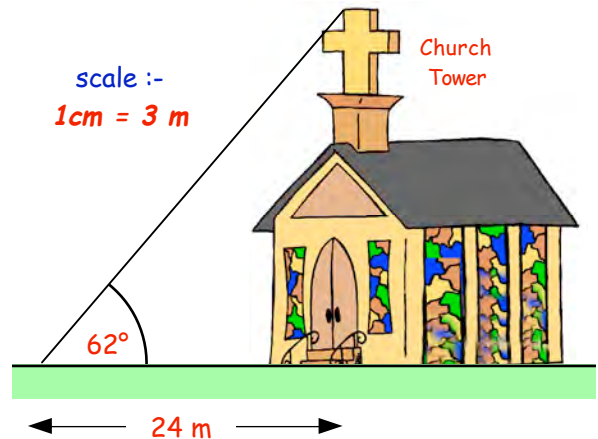

7. The diagram shows the journey made by a small mail delivery boat as it sailed around the islands.

Bruff Island is due East of the mainland and Nark Island is North of Bruff.

a Draw a triangle to scale, showing the boat's journey.

$$\text{scale } 1 \text{ cm} = 2.5 \text{ km.}$$

b Measure the distance between the 2 islands in centimetres and calculate the **real** distance between them in kilometres.

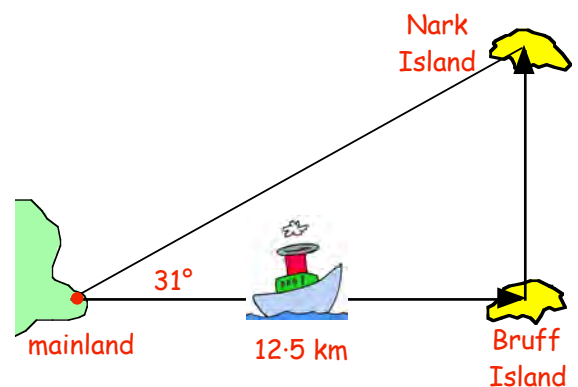

- 8.

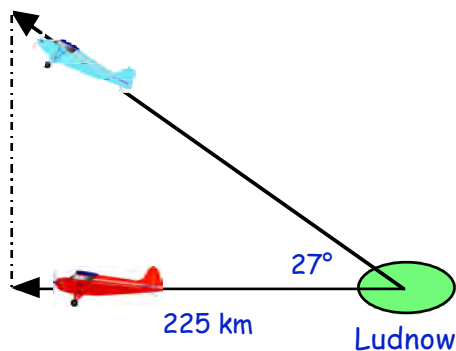

Two air planes set off from Ludnow airfield.

One of them sets off on a course due West.

The sketch shows where they are after 15 minutes.

One plane is exactly North of the other one.

a Make a scale drawing showing the paths of both planes using the scale

$$1 \text{ cm} = 25 \text{ km.}$$

b Calculate how far apart the 2 planes are at the end of the 15 minutes.

Compass Points and Scale Drawings

Revision of Level D work

Exercise 4

1. Make a copy of the compass rose and fill in the other 4 missing main directions.

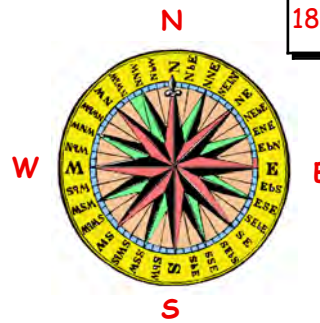

Remember

$360^\circ = 1$ full turn

$180^\circ = \frac{1}{2}$ turn, $90^\circ = \frac{1}{4}$ turn

2. How many degrees are there from :-

- | | |
|-----------------------------------|---------------------------------------|
| a North to East (clockwise) | b North to South (clockwise) |
| c North to West (clockwise) | d North to West (anti-clockwise) |
| e North to North East (clockwise) | f North to South East (clockwise) |
| g East to West (anti-clockwise) | h South East to West. (clockwise) |
| i North West to East (clockwise) | j East to North West (anti-clockwise) |

3. a Sandy was facing West. He then made a $\frac{1}{4}$ turn anti-clockwise. In which direction was Sandy facing ?

b Billy was driving North East when he came to a hairpin bend. He then turned his car through 180° clockwise. In which direction was Billy then driving ?

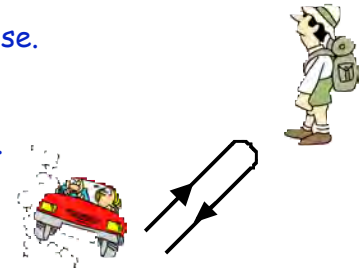

c A tank commander was driving his tank North East. The tank then turned through 90° clockwise. In which direction did the tank end up travelling ?



4. The map shows Foggy Island.

The town of Kirkton lies at a point around the middle.

a If I was in Kirkton, where would I be looking towards if I faced :-

(i) South ? (ii) East ?
 (iii) N West ? (iv) S East ?

b Where are the following in relation to Kirkton :-

- (i) the Marshland ?
 (ii) the River Brock ?
 (iii) Mons Mount ?
 (iv) the Harbour ?

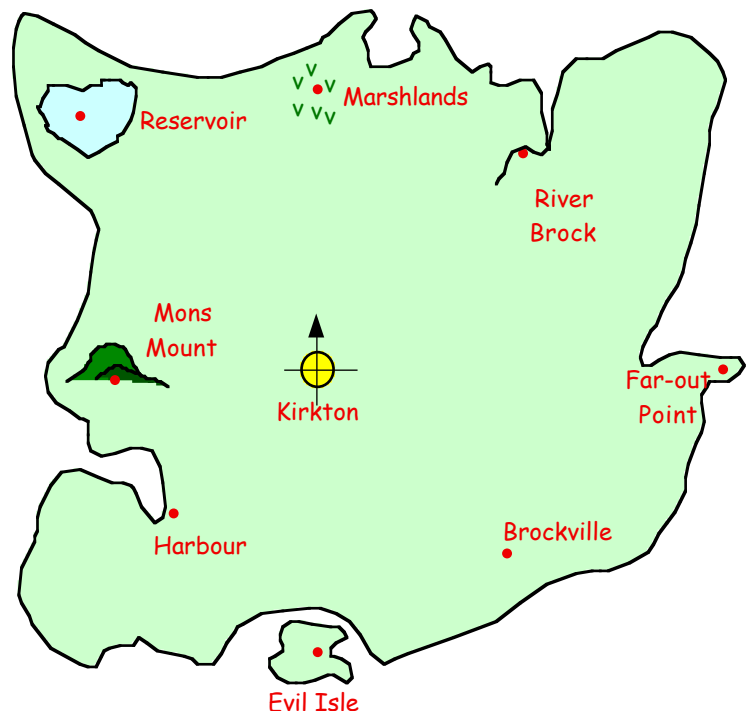

Three Figure Bearings and Scale Drawings

A different way of describing directions is to give them as **3-figure bearings**.

The diagram shows Ayrton with the north direction through it.

Can you see that if you stand at Ayrton, **facing north** and turn through **60° clockwise**, then you will end up facing Prassie ?

=> We say that Prassie lies "**on a bearing 060°**" from Ayrton.
(notice how we have used **three figures** to give the bearing).

Can you see also that if you stand at Ayrton, **facing north** and turn through **135° clockwise**, then you will end up facing Tonga ?

=> We say that Tonga lies "**on a bearing 135°**" from Ayrton.

- Note:-**
- (i) Bearings are **always** measured **CLOCKWISE** from the north direction.
 - (ii) Use your protractor, turned **on its side** to measure bearings.

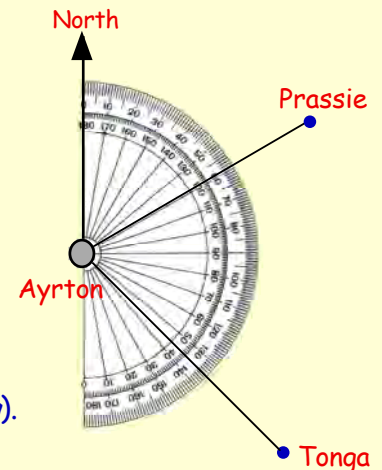

Exercise 5 You will need a **protractor** for this exercise.

- Look at the diagram showing Brighton and Whirl.
What is the 3-figure bearing of Whirl from Brighton ?
- Use a protractor (turned round) to measure the bearing of each town from Ackland.

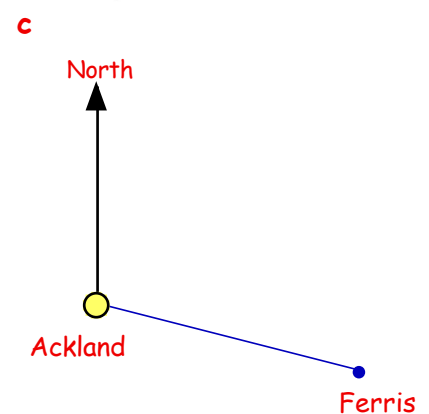
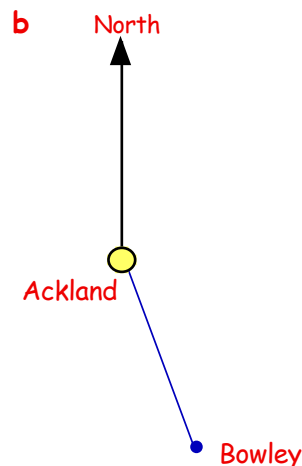
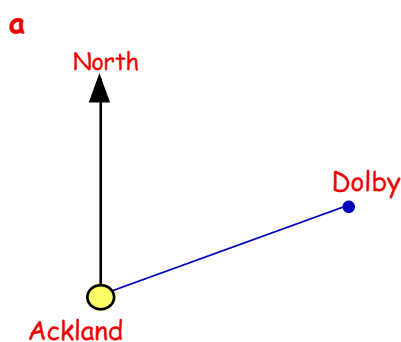
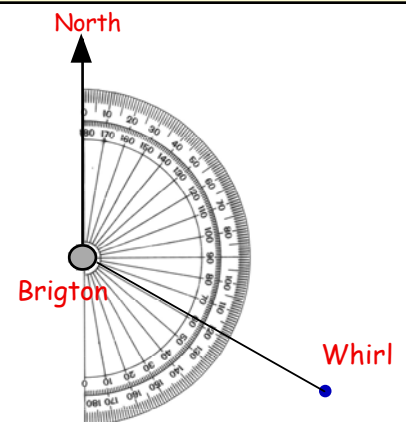

3. North, obviously, in 3-figure bearing terms is **000°**.

Write down the 3-figure bearing of the following :-

- a South
- b East (3 figures !)
- c South-East
- d North-East.

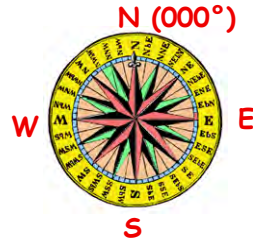

Even if the direction you are dealing with is further round than **south**, you still measure it "**clockwise**" from the North.

Can you see that Broom, in this figure, is 40° further round than south ?

=> it is $(40° + 180°) = 220°$ round from North

=> the 3-figure bearing of Broom from Alston is **220°**.

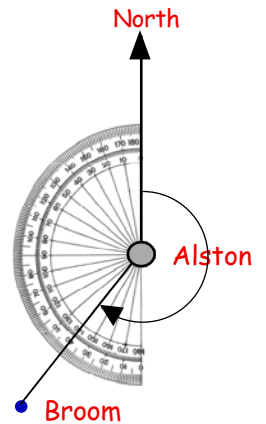

4. Write down the 3-figure bearing of the following directions :-

- a West
- b South West
- c North West.

5. The diagram shows 2 towns - Breston and Norley.

Write down the 3-figure bearing of Norley from Breston.

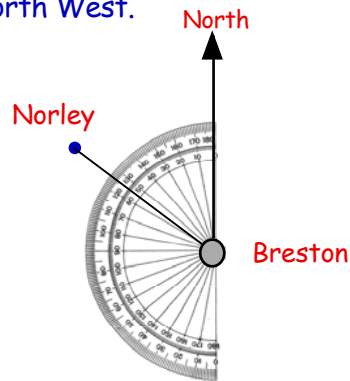

6. Use a protractor (turned round) to measure the bearing of each town from Dunstan.

a

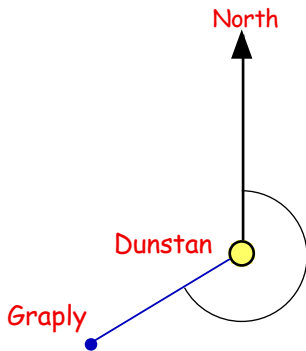

b

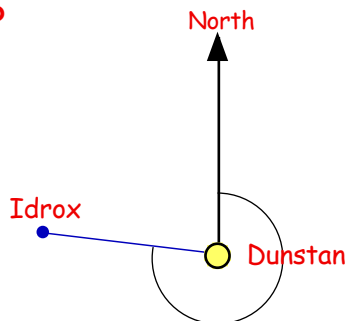

c

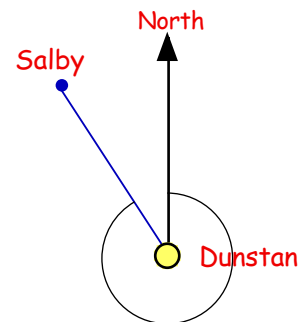

7. Use your protractor to write down the 3-figure bearing of each of these towns from Edinglow.

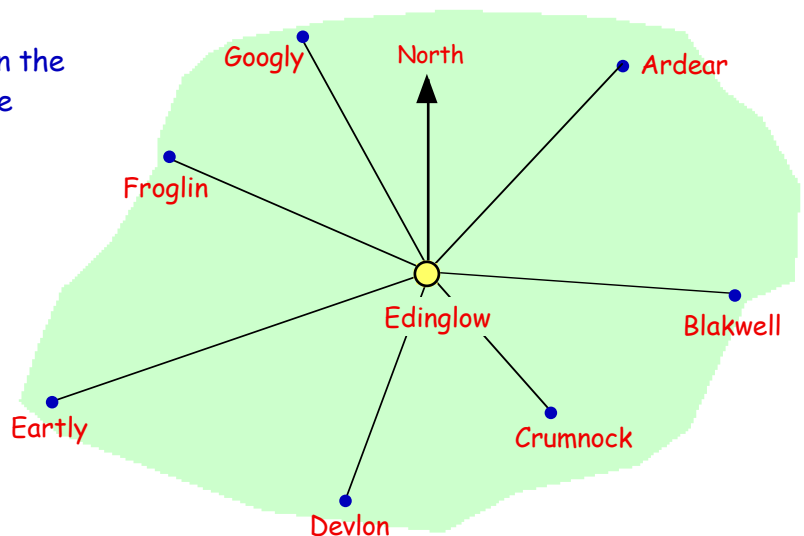

8. Mark a point on the page of your jotter and call it point **A**.
Draw a North line through your point.

Show, using your protractor, point **B**, such that **B** is on a bearing 085° from **A**.

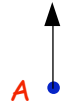

9. Two aircraft leave Edinburgh Airport at the same time.
The Cessna plane travels 95 kilometres on a bearing of 040° .
The helicopter flies 55 kilometres on a bearing of 145° .

- a Make a scale drawing of the two journeys.

scale $1\text{ cm} = 10\text{ km}$.

- start by marking a point on your page to show **E**.
- draw in the north-south and east-west lines thru' **E**.
- use your protractor to show the 40° from north.
- use your ruler to show the Cessna's journey.
- repeat for the helicopter's trip.

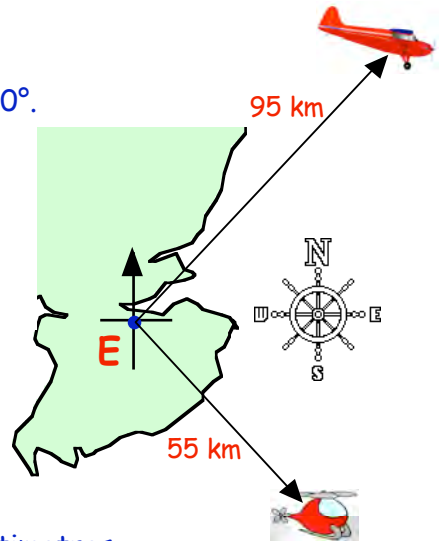

- b Measure the distance between the two aircraft in centimetres.
c Now calculate the **real** distance between them in kilometres.

10. Two teams set off from a base camp as part of a military exercise.
Blue command travel for 6.5 kilometres on a bearing 250°
Red command travel for 8 kilometres on a bearing 140° .

- a Make a scale drawing of the two journeys.

scale $1\text{ cm} = 1\text{ metre}$.

- b Measure the distance between the two teams, in centimetres.
c Now calculate the **real** distance between the two teams, in kilometres.

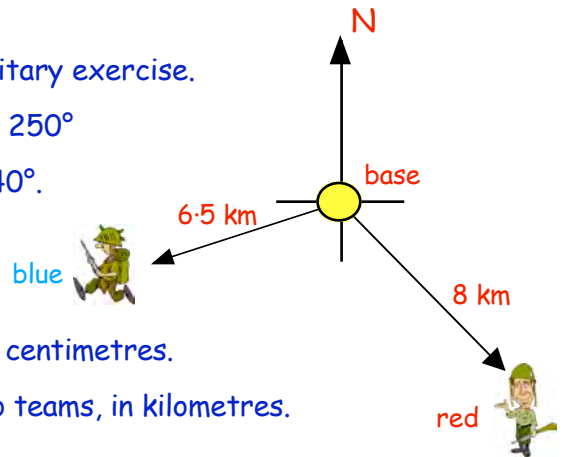

11. A ship leave Dorwick Harbour.
It sailed for 45 kilometres on a bearing of 060° to Parker Island.
It then sailed from Parker Island for 30 kilometres on a bearing of 130° to Scapa Point.

- a Make a scale drawing showing the two stages of the trip.

scale $1\text{ cm} = 5\text{ km}$.

- b Measure the distance from Dorwick Harbour to Scapa Point in centimetres.
c Calculate the **real** distance from Dorwick Harbour to Scapa Point, in kilometres.

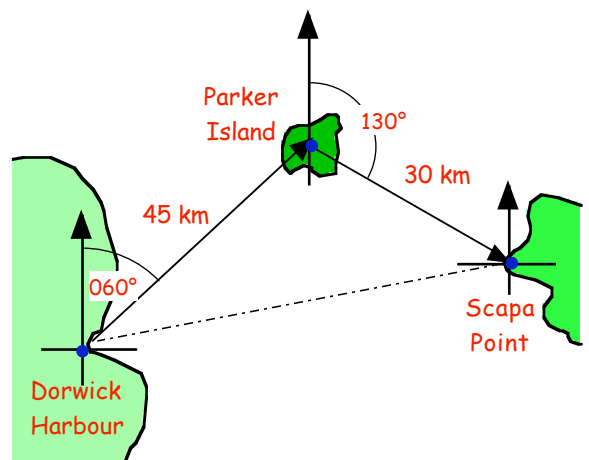

Topic in a Nutshell

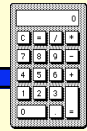

1. This shape has been drawn using a scale :-

1 cm = 10 m.

- a Measure the length of the ship with a ruler.
- b Calculate the length of the **REAL** ship.



2. Shown is a scale drawing of a swimming pool.

The scale is **1 cm = 5 m.**

- a Measure the length and breadth of the swimming pool.
- b Calculate the real length and breadth of the swimming pool.
- c Jack swims from one corner of the pool to his dad at the opposite corner of the pool. How far does Jack swim to reach his dad ?

Jack

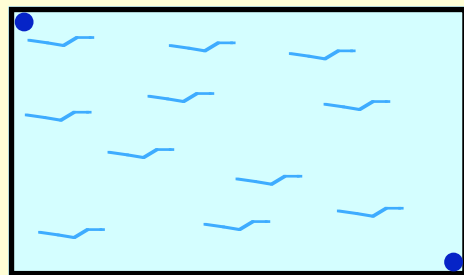

Dad

3. a Make a neat scale drawing to show this tree as it is viewed from point P.

The scale is **1 cm = 2 m.**

- b Measure the length from the top of the tree to point P on your drawing.
- c Work out the real distance from the top of the tree to point P.

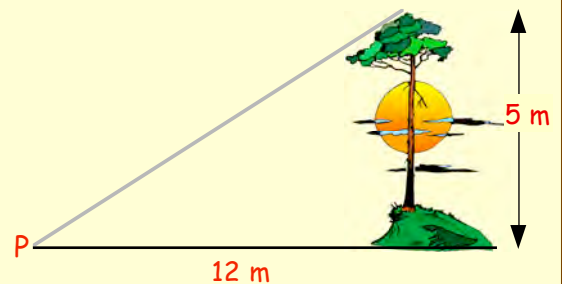

- 4.

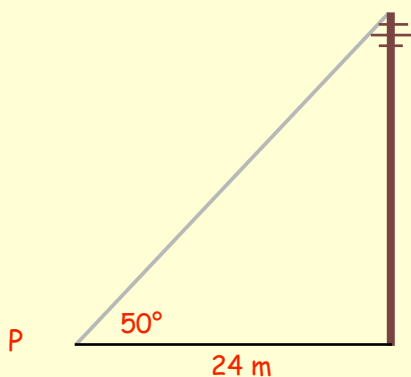

- a Use a ruler and protractor to make a scale drawing using the scale :-

1 cm = 4 m.

- b Calculate the **real** height of the telegraph pole in metres.

5. I am walking in a North-East direction.
I make a 270° turn anti-clockwise.
In which direction am I now heading ?



6. Use a **protractor** to measure the bearing of each of the three towns, Appleby, Priestley and Kilburn from South Berwick.

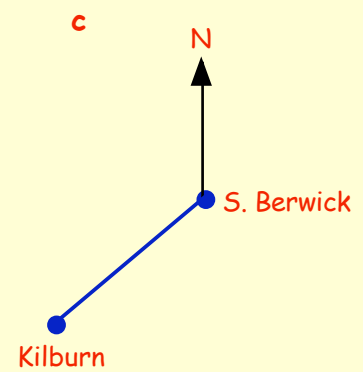
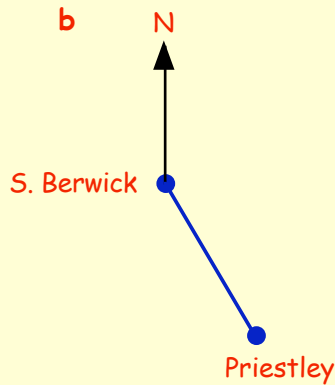
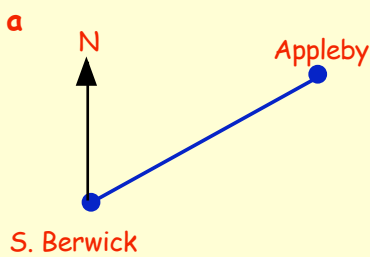

7. This sketch shows the journey made by the aircraft carrier Ark Royale. It sailed **North East** from Kasa Harbour for 70 km to Barra Island. From there, it sailed **East** for 50 km to Dagbad.

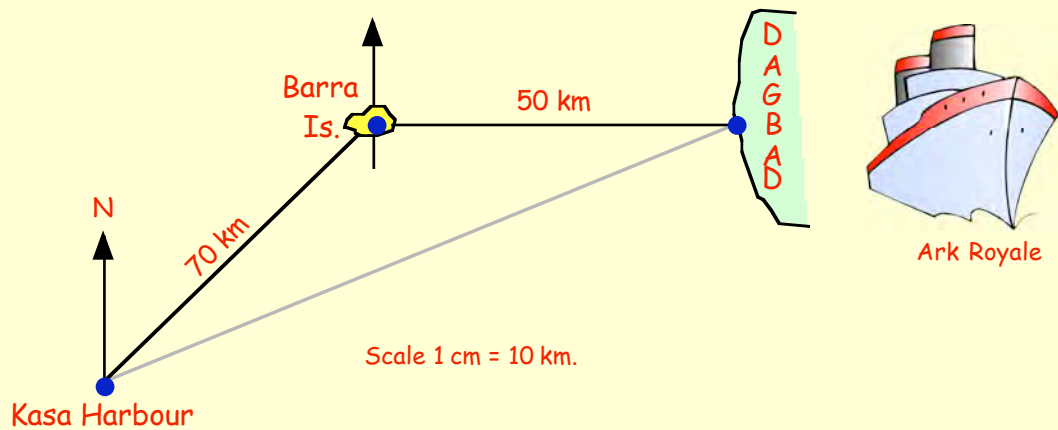

- Make a scale drawing showing the route taken by the Ark Royale.
- Measure the distance from Kasa Harbour to Dagbad on your scale drawing.
- Calculate the distance the battleship had to travel to return to Kasa Harbour from Dagbad.

8. On an orienteering trip, Toni sets off from the start and walks for 2 kilometres on a bearing 130° to stage 1.

She decides to give up and begins to head back to the start.

On what bearing should she head from stage 1 to get safely back to the start?

(Do not measure)

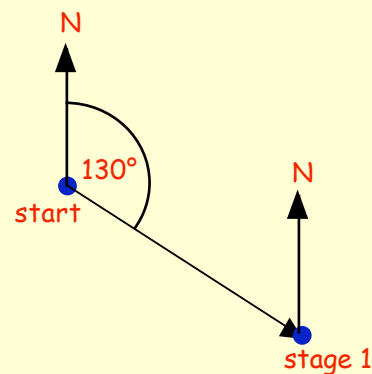

Chapter 18



Quadrilaterals

Quadrilaterals

A Definition

Definition — A quadrilateral is defined as
 "A closed 4 sided linear shape".

— this means the shape is made up of 4 straight lines.

Reminder :- You should already have studied two types of quadrilaterals -
 the **square**  and the **rectangle** .

New work :- We will look at four other special types of quadrilaterals -

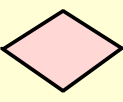

rhombus



kite

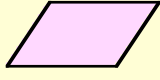

parallelogram

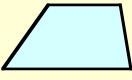

trapezium

The Square

A revision exercise

Exercise 1

1. Use a ruler to draw a neat square **ABCD** with sides 4 centimetres.

Answer the following questions about the square :-

- a Are all four sides the same length ?
- b Are the opposite pairs of sides parallel ?
- c Are all four angles the same size ?
- d How many lines of symmetry has the square ?
- e Does it have (i) $\frac{1}{2}$ turn symmetry ? (ii) $\frac{1}{4}$ turn symmetry ?
- f If this square was cut out of the page, in how many ways could it fit back in the hole left in the page ?

Now carefully draw in the two diagonals, **AC** and **BD** meeting in the middle at **M**.

- g Are the two diagonals the same length ?
- h Does each diagonal **bisect** the other one (cut it in half) ?
- i Do the two diagonals cross each other at right angles (is $\angle AMB = 90^\circ$) ?
- j Does each diagonal "bisect" the end angle (i.e. does **AC** cut $\angle BAD$ in half) ?

(The above are called the "**PROPERTIES**" of the square).

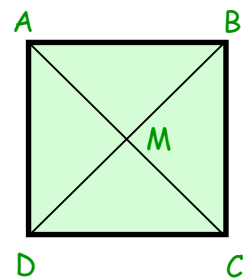
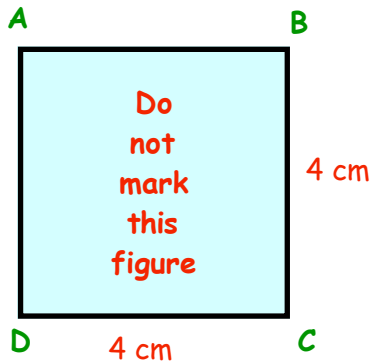

2. The square is the most "perfect" of all quadrilaterals.

Make a list of at least 10 "properties" as follows :-

- (i) All 4 sides are the same length.
- (ii) The opposite sides are par..... .

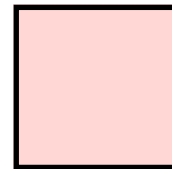

3. Look at the square shown opposite.

- a Make a neat sketch of it.
- b Fill in the sizes of every other side and angle.

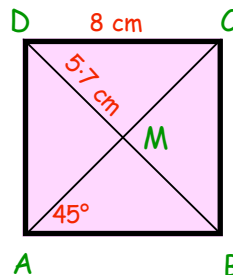

4. a Draw a square, PQRS, with sides 6 centimetres.

b Draw in the 2 diagonals, PR and QS, and measure their lengths.

5. Harder !!

- a Draw a square with its two diagonals 10 centimetres.
(hint : make sure they bisect each other at right angles)
- b Measure the lengths of each of the sides of the square.

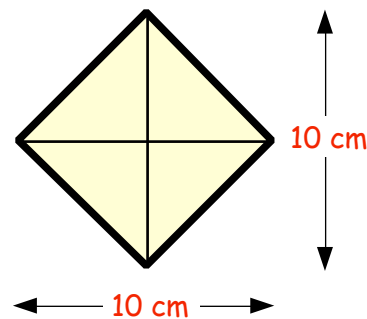

6. a Draw another square with its diagonals 12 centimetres.

b Measure the lengths of each of its sides.

7. a Draw a square which has a PERIMETER of 28 centimetres.

b Measure the lengths of its diagonals.

8. You learned in Chapter 10 that the area of a square is given by

$$A = L \times B \quad (\text{or } A = L^2)$$

- a Calculate the area of a square with sides 5 cm.
- b Calculate the area of a square with sides 12 cm.
- c Calculate the area of a square with sides 3.5 cm.
- d Check that the square in Question 5, has an area of 50 cm².

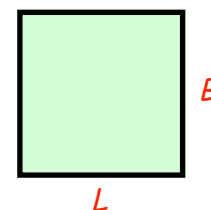

9. Harder !! A square has an area of 81 cm².

- a What is the length of each of its sides ?
- b Calculate the perimeter of the square.

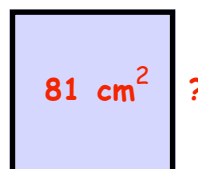

10. Shown are 2 congruent squares, ABCD and DCEF, side by side.

Calculate the size of $\angle ADE$.

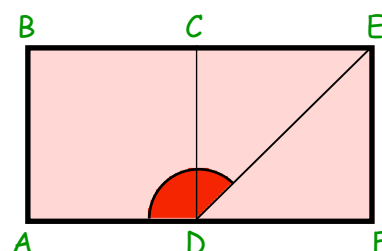

The Rectangle

Revision Exercise

Exercise 2

1. Use a ruler to draw rectangle PQRS
7 centimetres by 4 centimetres.

Answer the following questions
about the rectangle :-

- Are all four sides the same length ?
- Are opposite pairs of sides the same length ?
- Are opposite pairs of sides parallel ?
- Are all four angles the same size ?
- How many lines of symmetry has the rectangle ?
- Does it have (i) $\frac{1}{2}$ turn symmetry ? (ii) $\frac{1}{4}$ turn symmetry ?
- If the rectangle was cut out, in how many ways could it be fitted back into the page ?

Now carefully draw the two diagonals, PR and QS meeting
in the middle at M.

- Are the two diagonals the same length ?
- Does each diagonal bisect the other one (cut it in half) ?
- Do the two diagonals cross each other at right angles (is $\angle PMQ = 90^\circ$) ?
- Does each diagonal "bisect" the end angle (is $\angle MSP = \angle MSR$) ?

(The above are called the "PROPERTIES" of the rectangle).

2. Make a list of 5-6 "PROPERTIES" of a rectangle which make it different from a square.

You could start like this :-

- The rectangle does **NOT** have all its four sides the same length.
-

3. Look at the rectangle shown opposite.

- Make a neat sketch of the rectangle.
- Fill in the sizes of the other five lengths.

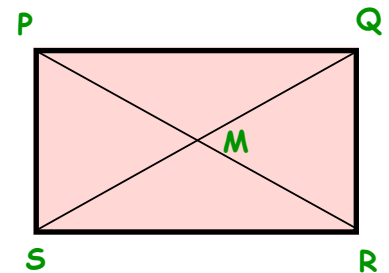
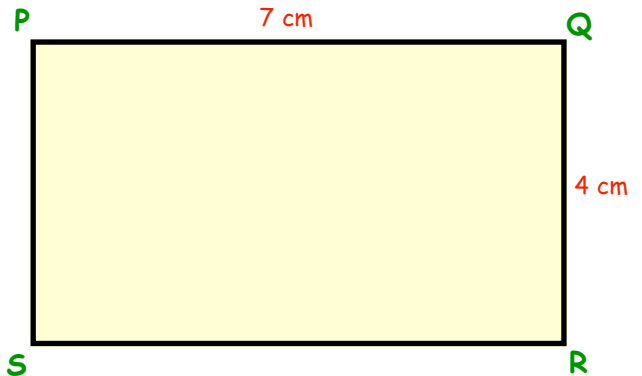
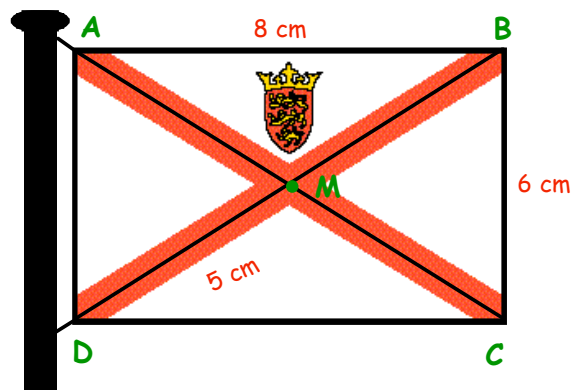

4. a Neatly and accurately draw a rectangle measuring 4 cm by 3 cm.
 b Measure the lengths of its 2 diagonals.

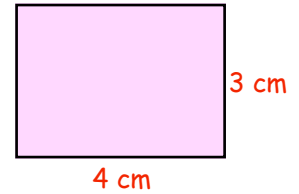

5. Draw a rectangle with its diagonals 10 centimetres long.

(note 1: start with one diagonal, find its mid-point, and draw a 2nd diagonal through this mid-point)
 (note 2: your rectangle will look different from your neighbours)

6. Draw a rectangle with its diagonals 7 centimetres long.
7. a Draw a rectangle with a perimeter of 16 centimetres.
 b Draw a different rectangle with a perimeter of 16 centimetres.
 c Draw a third rectangle with a perimeter of 16 centimetres.
 d If you start to draw a rectangle with perimeter 16 cm and you begin with one of its sides 4 cm long, what "special" type of rectangle will you end up with?

8. You learned in Chapter 10 that the area of a rectangle is given by

$$A = L \times B$$

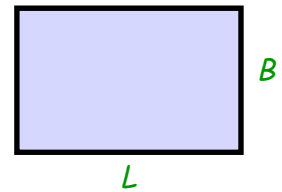

Calculate the area of a rectangle measuring 8 cm by 4 cm.

9. Calculate the areas of the following rectangles :-

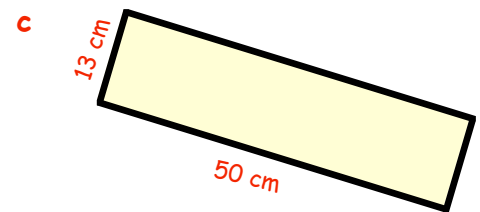
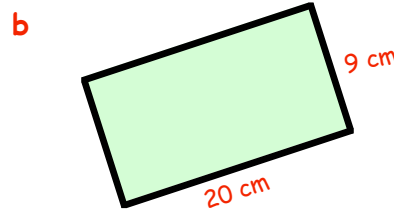
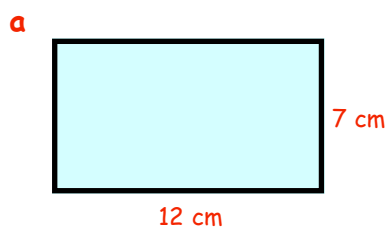

10. Look at the rectangle IJKL.

- a What are the lengths of sides, IL and LK?
 b Write down the sizes of $\angle LIJ$ and $\angle LKJ$.
 c Now calculate the sizes of the missing angles.

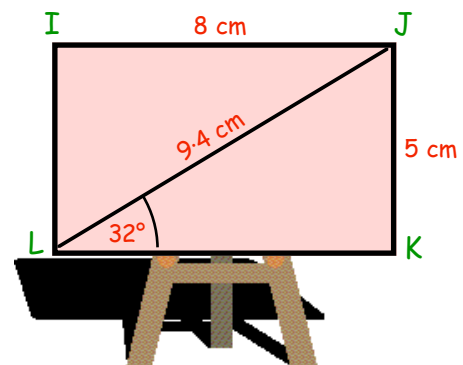

11. Sketch the following rectangles and fill in the sizes of the missing sides and angles :-

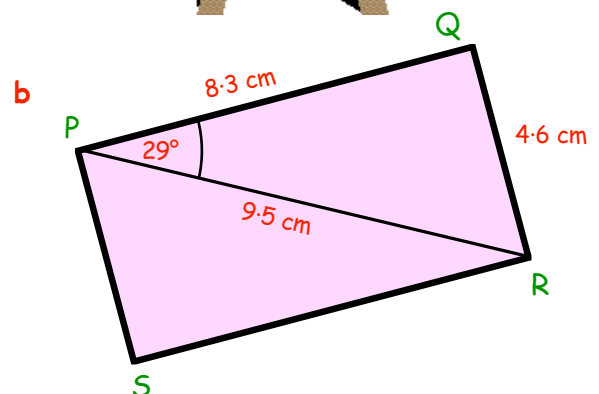
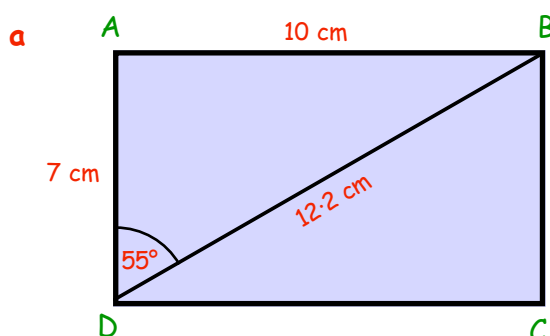

12. Look at the rectangle WXYZ.

- a Calculate the size of :-
 (i) $\angle MXW$ (ii) $\angle MWZ$.
 b Sketch the figure and fill in the sizes of all the missing angles.

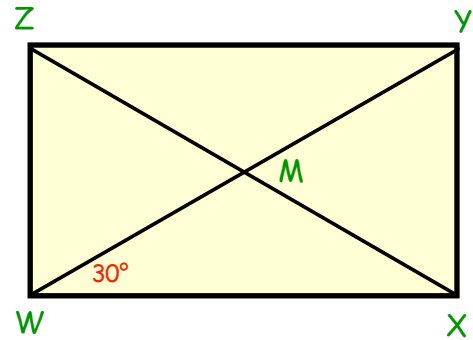

Sketch the figure TWPQ and fill in the sizes of all the missing sides and angles.

13.

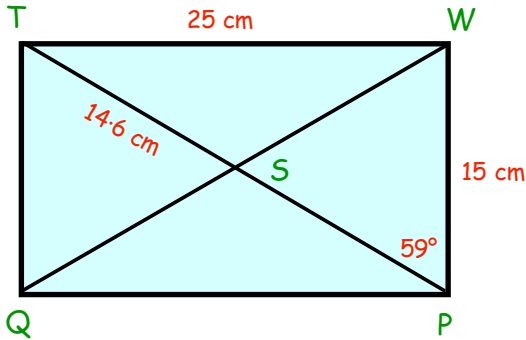

14. Do the same for the following two rectangles :-

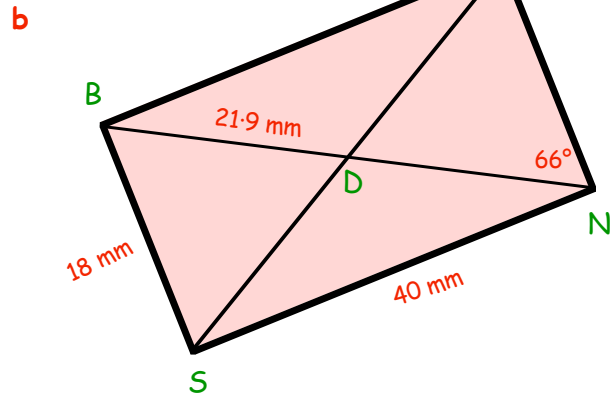
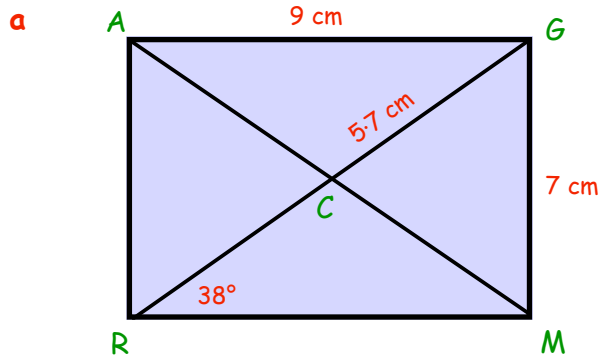

15. Shown is a rectangle PQRS and a square QRTV.
 Calculate the size of $\angle PRT$.

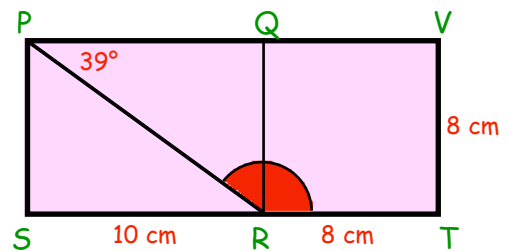

16.

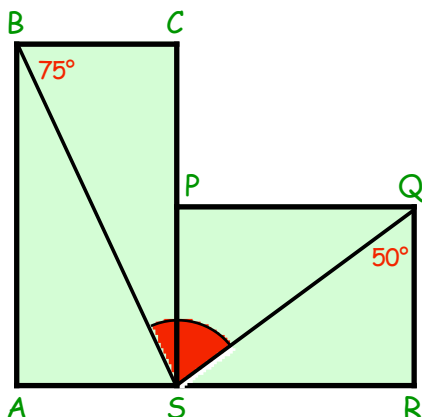

Look at the 2 rectangles, ABCS and PQRS, joined at PS.

- a Make a neat sketch of this figure.
 b By working out the sizes of the missing angles, calculate the size of $\angle BSQ$.

The Other 4 Quadrilaterals

The four angles of a Quadrilateral

By this stage, you should have learned that the three angles of a triangle always add to give 180° .

$$x + y + z = 180^\circ$$

There is a similar rule connecting the four angles of a quadrilateral.

Look at $\triangle ABC$, $y + b + c = 180^\circ$

Look at $\triangle ADC$, $x + a + d = 180^\circ$

Can you see that the four angles of the quadrilateral add to

$$\begin{aligned} & x + y + z + w \\ &= x + y + (a + b) + (c + d) \\ &= (x + a + d) + (y + b + c) \\ &= 180 + 180 = 360^\circ \\ &\Rightarrow x + y + z + w = 360^\circ \end{aligned}$$

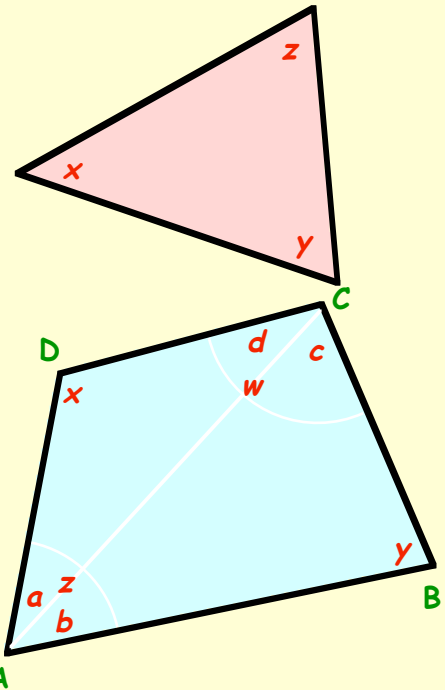

The four angles of a quadrilateral ALWAYS add to give 360°

Exercise 3

1. Look at quadrilateral PQRS.

- Find $110 + 120 + 60$.
- What must the size of $\angle PSR$ be?

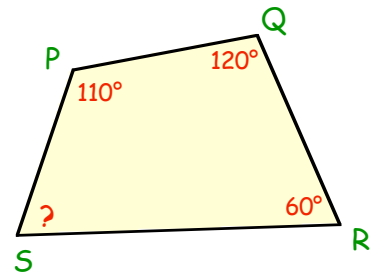

2. Sketch the following quadrilaterals and calculate the values of x , y , z and w :-

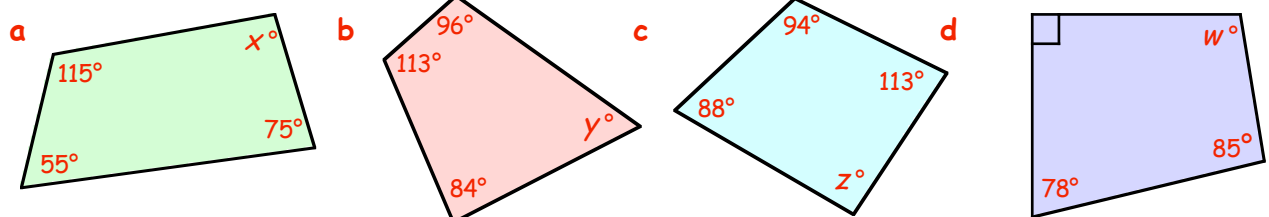

3. This shape is called a Trapezium.
(you will meet it later on)
Calculate the size of the angles marked *.

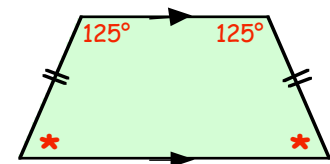

4. Three of the angles in this kite are the same size (x).
Calculate the value of x .

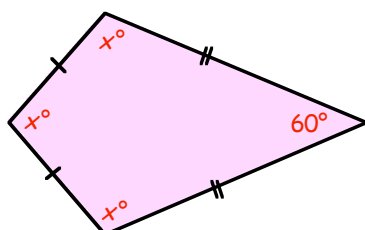

The Rhombus

The Rhombus (Diamond)

You can think of a rhombus as a "SQUASHED SQUARE".

it has some of the properties of a square, but not all of them.

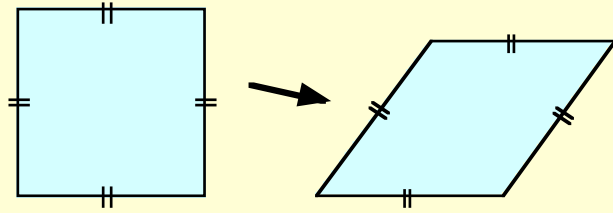

Exercise 4

- Use a ruler to draw the following rhombus (or trace it into your jotter)

Its diagonals are 8 cm and 4 cm.

Answer the following questions about the rhombus :-

- Are all four sides the same length ?
- Are the opposite pairs of sides parallel ?
- Are all four angles the same size ?
- Are opposite pairs of angles the same size ? ($\angle BAD$ and $\angle BCD$)
- How many lines of symmetry has the rhombus ?
- Does it have (i) $\frac{1}{2}$ turn symmetry ? (ii) $\frac{1}{4}$ turn symmetry ?
- If the rhombus was cut out, in how many ways could it be fitted back in the page ?

Now carefully draw the two diagonals, AC and BD meeting in the middle at M .

- Are the two diagonals the same length ?
- Does each diagonal bisect the other diagonal ?
- Do the two diagonals cross each other at right angles (is $\angle BMA = 90^\circ$) ?
- Does each diagonal "bisect" the end angle (i.e. is $\angle BAM = \angle DAM$) ?

(The above are called the "PROPERTIES" of the rhombus).

- Make a list of 4-5 "PROPERTIES" of a rhombus which make it different from a square.

- The rhombus does **NOT** have all its 4 angles the same size.
- It only has ... lines of symmetry unlike the square's 4 lines of symmetry.
-

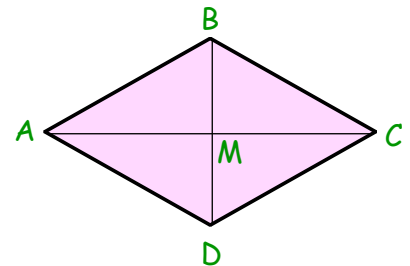
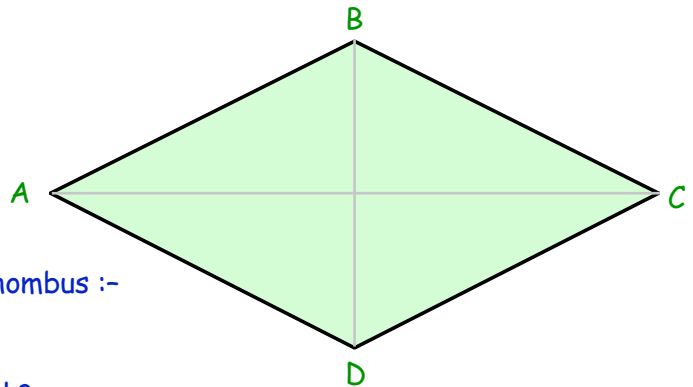

3. Look at the rhombus, PQRS.
- What are the lengths of the lines QR, RS and PS ?
 - What are the lengths of the lines PM and SM ?

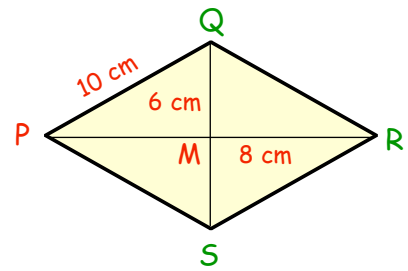

4. The easiest way to draw a "NEAT" accurate rhombus is :-

- not by drawing its four sides first
- but drawing its two diagonals first

The diagram shows how to draw a rhombus, ABCD with diagonals 8 cm and 4 cm.

Use the instructions to draw rhombus ABCD.

- Draw rhombus PQRS with diagonal PR = 10 cm and diagonal QS = 6 cm.
 - Measure the length of each of its 4 sides.
6. Draw a rhombus with diagonals 12 cm and 7 cm.
- Draw a rhombus with diagonals 6 cm and 6 cm.
 - What "special" type of rhombus have you created ?

Step 1 : draw diagonal AC = 8 cm

Step 2 : find its centre

Step 3 : draw diagonals BD = 4 cm passing through M (at 90°) to AC

Step 4 : join A → B → C → D

8. Look at the rhombus FGHI.
- What is the size of :-
- $\angle GHJ$?
 - $\angle FGH$?
 - $\angle FJH$?
9. Write down the sizes of the missing angles in each of the following rhombii :- (plural of rhombus)

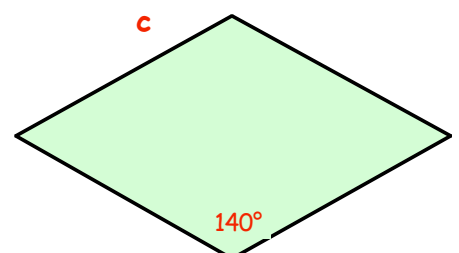
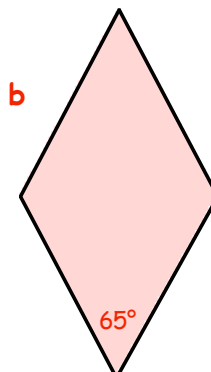
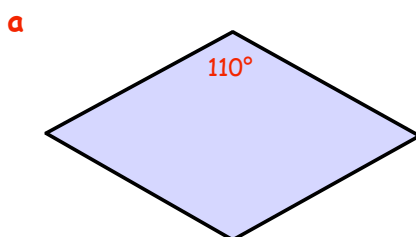
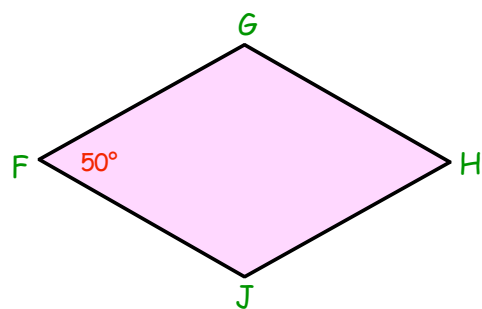

10. In this rhombus, one diagonal has been drawn.

- a What "special" kind of triangle is $\triangle ETZ$?
- b Write down the size of $\angle EZT$?
- c Calculate the size of $\angle ETZ$.
- d Write down the sizes of the other three angles.

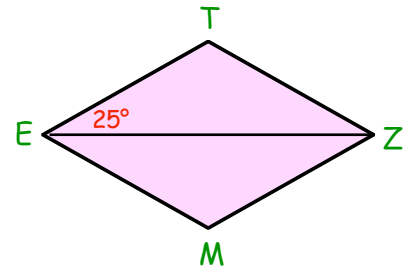

11. Make neat sketches of the following rhombii and fill in the sizes of all the missing angles :-

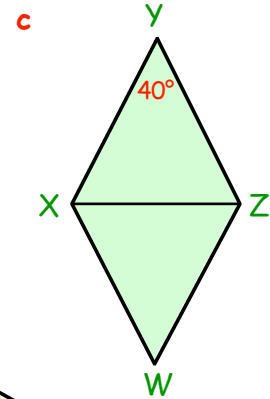
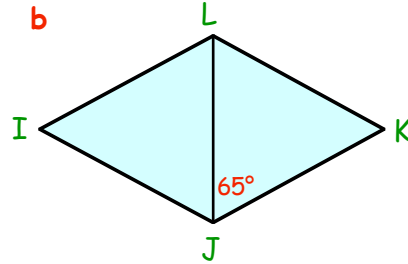
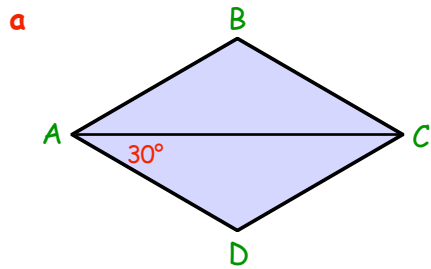

12. This time, both diagonals are shown in rhombus, LMNP.

Make a large sketch and fill in the size of all 11 missing angles.

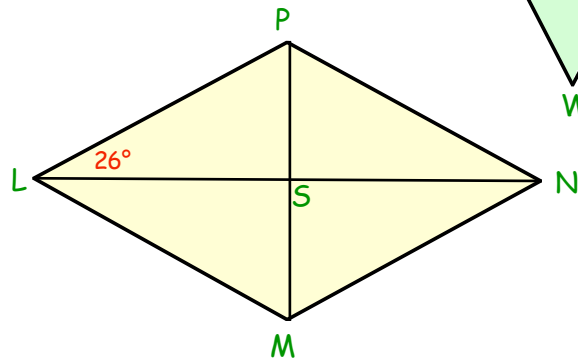

13. Sketch these rhombii and fill in the sizes of all the missing angles :-

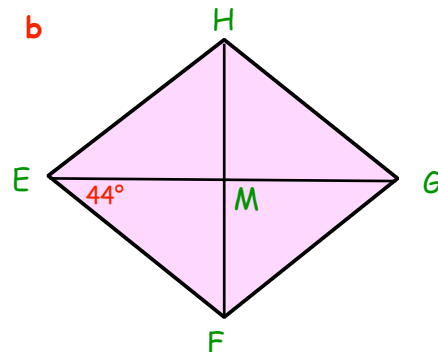
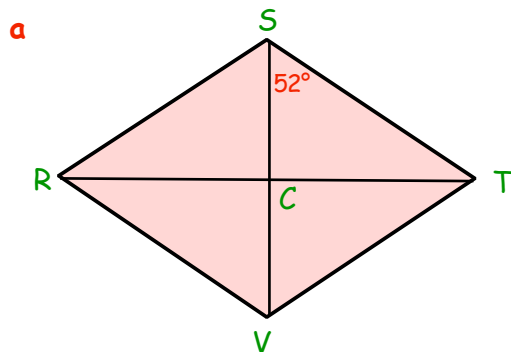

14. Look at the figure in Question 13b.

if $\angle MEF$ had been 45° instead of 44° , what "special" type of rhombus would EFGH have turned into ?

15. Look at rhombus KMNP.

$$\angle KPN = 100^\circ$$

Sketch the rhombus and fill in the sizes of all the missing angles.

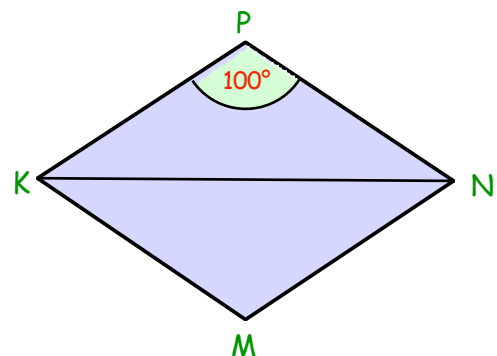

16. This figure consists of six identical rhombii around a point, P.

- a Calculate the size of one of the angles at the centre ($\angle HPJ$).
(think !!)
- b Now calculate the size of the shaded angle $\angle IHP$.

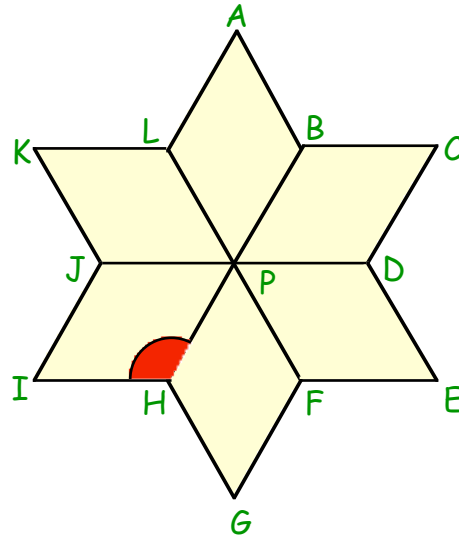

17.

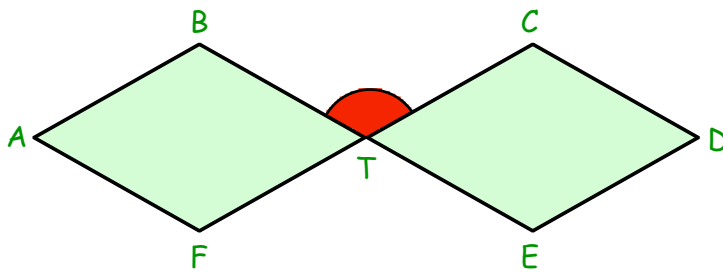

2 identical rhombii are shown opposite touching at point, T.

Calculate the size of $\angle BTC$.

18.

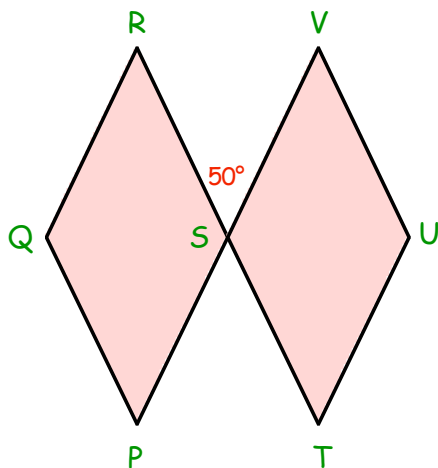

Shown are 2 congruent rhombii, PQRS and STUV with angle $RSV = 50^\circ$.

Calculate the sizes of all the missing angles.

19. Two rhombii, EFGH and RSTU overlap as shown.

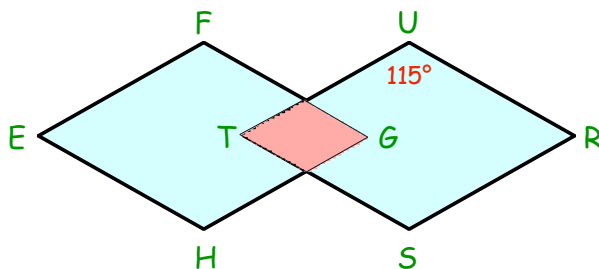

if angle $TUR = 115^\circ$, calculate the sizes of the four angles in the small red rhombus.

The Kite

The paper and string toy flown in the wind is named after this mathematical shape.

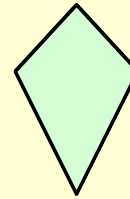
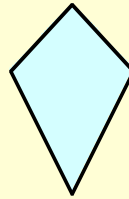
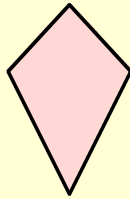

Exercise 5

- Use a ruler to make a neat accurate drawing of this kite. (or trace it into your jotter).
(Start by drawing the 2 diagonals)

Answer the following questions about the kite :-

- Are all four sides the same length ?
- Are **opposite** sides the same length ?
- Are there any pairs of equal sides ?
- Are the opposite sides parallel ?
- Are all four angles the same size ?
- Are the top and bottom angles the same size ?
- Are the right and left angles the same size ?
- How many lines of symmetry has the kite ?
- Does it have $\frac{1}{2}$ turn symmetry ?
- If the kite was cut out, in how many ways could it be fitted back into the remaining hole ?

Now carefully draw the two diagonals, **AC** and **BD** meeting at the point **T**.

- Are the two diagonals the same length ?
- Does diagonal **AC** bisect **BD** (cut it in half) ?
- Does diagonal **BD** bisect **AC** (cut it in half) ?
- Do the two diagonals cross each other at right angles (is $\angle BTA = 90^\circ$) ?
- Does diagonal **AC** cut the end angles in half (is $\angle BCT = \angle DCT$) ?
- Does diagonal **BD** cut the end angles in half (is $\angle ABT = \angle CBT$) ?

(The above are called the "**PROPERTIES**" of the kite).

- Make a list of the "**PROPERTIES**" of a kite which make it different from a square.

- Unlike the square, the kite does **NOT** have all its sides the same length.
- Unlike the square, its opposite sides are not parallel.
-

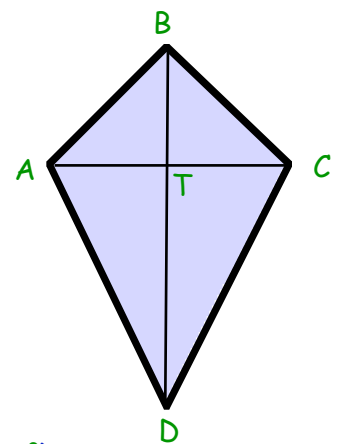
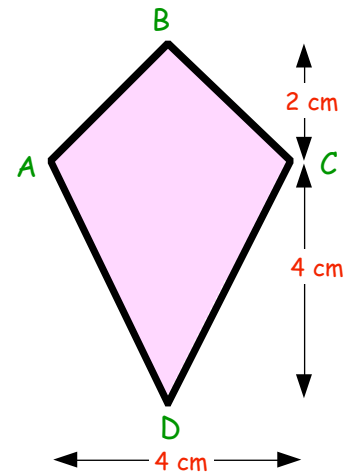

3. Look at the kite, PQRS.

What are the lengths of the 3 lines PQ, PS and PT?

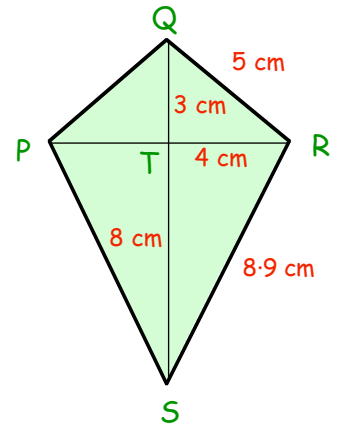

4. Look at the kite LNGV.

a Write down the size of :-

(i) $\angle LVG$ (ii) $\angle VLG$.

b Calculate the size of :-

(i) $\angle NGL$ (ii) $\angle VGL$.

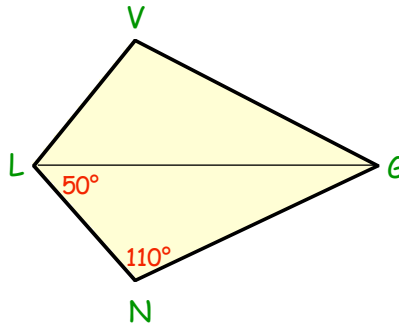

5. Make neat sketches of the following kites and calculate the sizes of all the missing angles :-

a

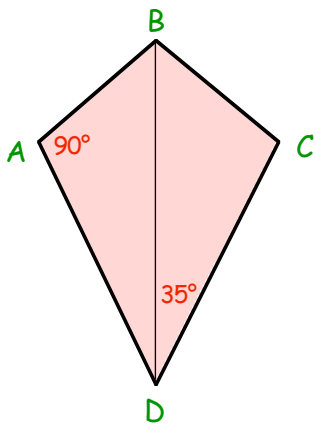

b

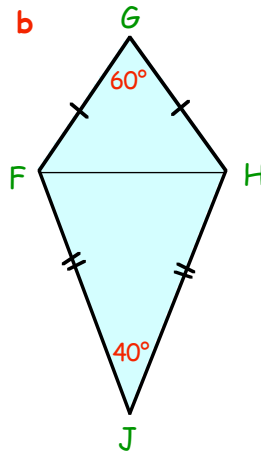

c

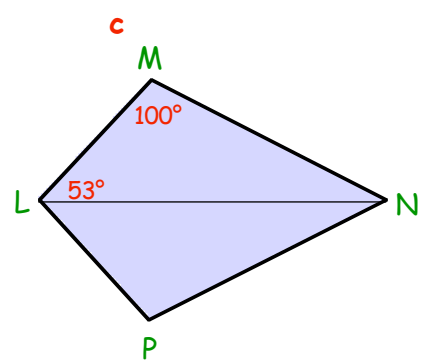

6. Look at the kite RSTV.

a Write down the size of :-

(i) $\angle STM$ (ii) $\angle MRV$ (iii) $\angle SMR$.

b Calculate the size of :-

(i) $\angle RSM$ (ii) $\angle RVM$ (iii) $\angle RVT$.

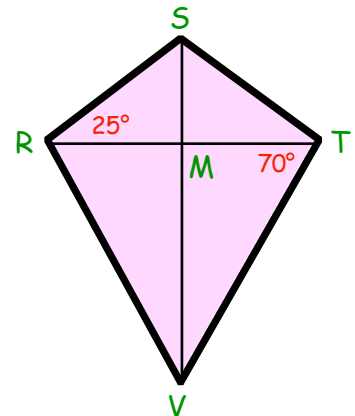

7. Make neat sketches of the following kites and calculate the sizes of all the missing angles :-

a

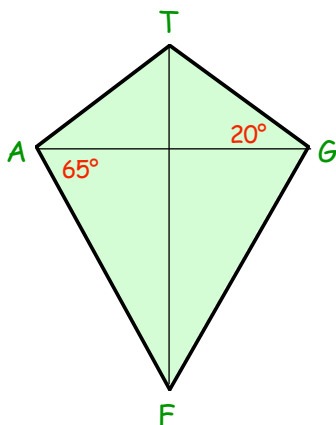

b

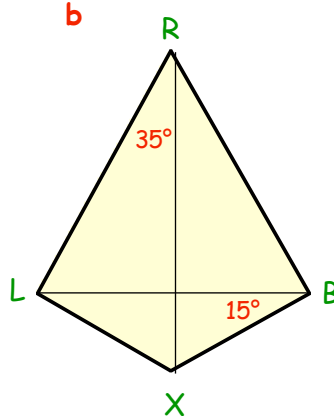

c

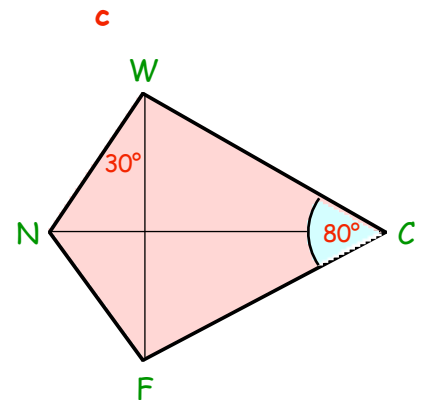

8. Nick, Lucy and Tom were asked to draw a kite which had diagonals 10 cm and 6 cm.

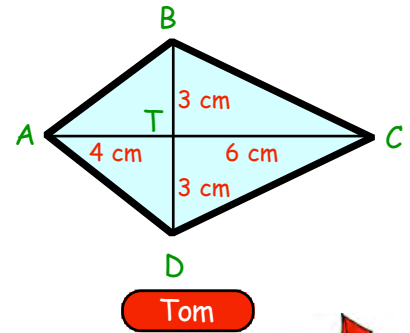
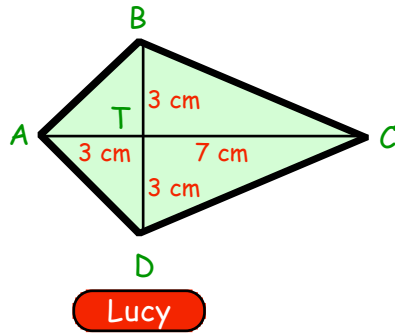
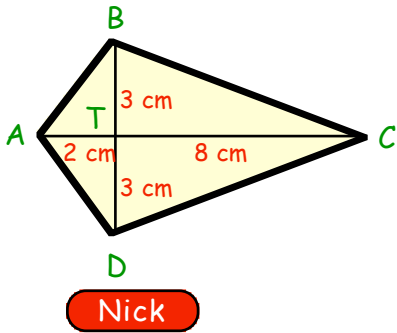

The above diagrams show how they drew the 3 different kites.

if you were asked to draw a kite like this, but with line $AT = 5$ cm, you would end up with a "special" type of kite. What type of kite would this be ?



9. This shape is made up of four identical kites.

$\angle API$ is a straight angle.

- a Calculate the sizes of $\angle APC$, $\angle CPE$, $\angle EPG$ and $\angle GPI$.
- b Use the figure to calculate the sizes of $\angle ABC$, $\angle CDE$, $\angle EFG$ and $\angle GHI$.

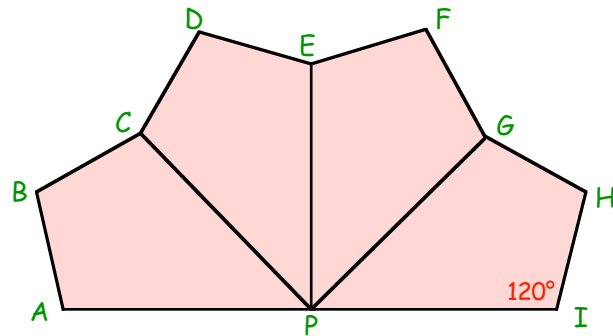

10. Calculate the sizes of the missing angles in the following kites :-

(Remember : the 4 angles of a quadrilateral ALWAYS add to)

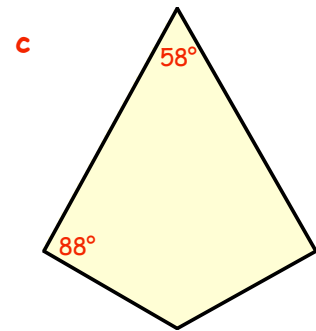
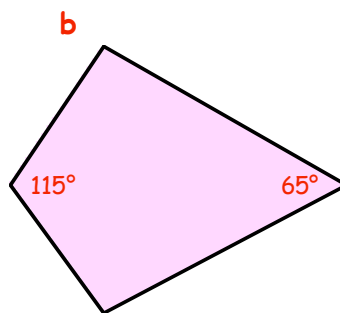
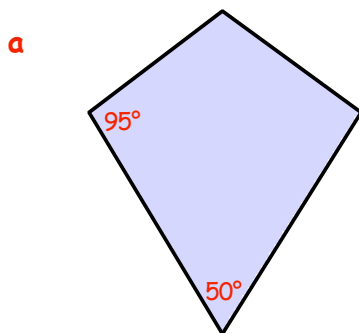

11.

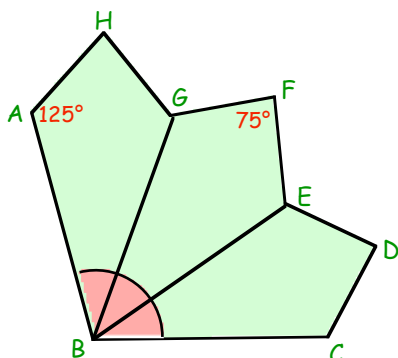

This shape consists of 3 identical kites with $\angle HAB = 125^\circ$ and $\angle GFE = 75^\circ$.

Calculate the size of obtuse $\angle ABC$.

The Parallelogram

As the name suggests, a parallelogram is a quadrilateral with both pairs of opposite sides **parallel**.

(A parallelogram is a squashed rectangle).

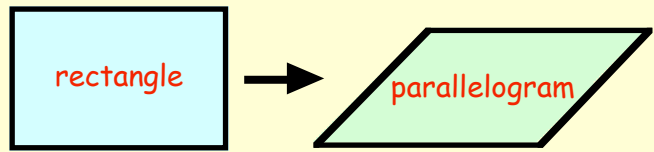

(Learn to spell parallelogram !)

Exercise 6

1. Use a ruler to make a neat drawing of a parallelogram like this. (or trace it into your jotter).

Answer the following questions about the parallelogram :-

- Are all four sides the same length ?
- Are **opposite** pairs of sides equal ?
- Are **opposite** pairs of sides parallel ?
- Are all four angles the same size ?
- Are **opposite** pairs of angles equal (i.e. $\angle DAB = \angle DCB$) ?
- Does it have (i) $\frac{1}{2}$ turn symmetry ? (ii) $\frac{1}{4}$ turn symmetry ?
- How many lines of symmetry does it have (Are you sure) ?
- If the parallelogram was cut out of the page, in how many ways could it be fitted back into the page ?

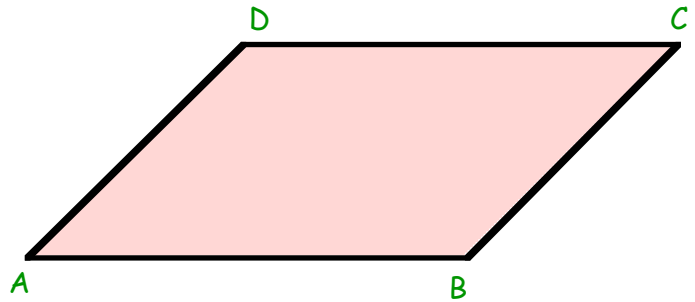

Now carefully draw the two diagonals, **AC** and **BD** meeting at **T**.

- Are the two diagonals the same length (Check by measuring) ?
- Does each diagonal bisect the other diagonal ?
- Do the diagonals meet at right angles (i.e. is $\angle DTC = 90^\circ$) ?
- Does each diagonal cut the end angle in half (i.e. is $\angle TAB = \angle TAD$) ?

(The above are called the "**PROPERTIES**" of the parallelogram).

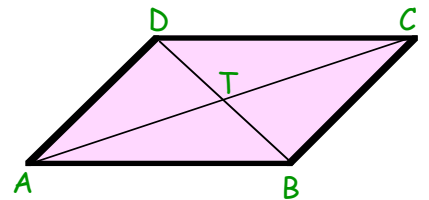

2. Write down "**PROPERTIES**" of a parallelogram which make it different from a rectangle.
- Unlike the rectangle, the parallelogram does **NOT** have all its angles equal.
 -

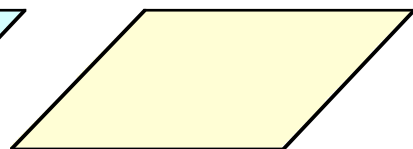
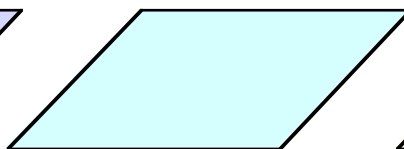
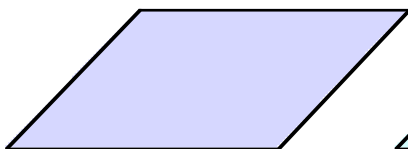

3. Sketch this parallelogram and fill in all the missing angles and sides.

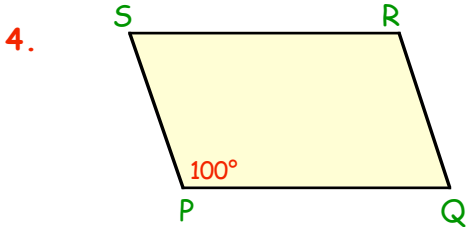
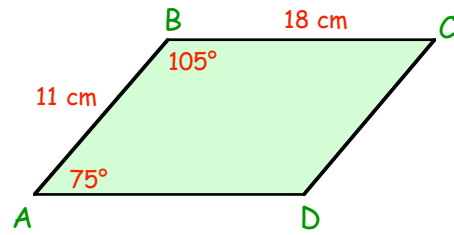

This time, you are given the size of one angle.

- What is the size of $\angle SRQ$?
- What must the sum of the four angles be ?
- Calculate the sizes of $\angle PSR$ and $\angle PQR$.

5. Did you notice the following ?

- From Question 3, what is the value of $75^\circ + 105^\circ$?
- From Question 4, what is the value of $80^\circ + 100^\circ$?
- What do you think will **ALWAYS** be true about the 2 **adjacent** angles in a parallelogram ?

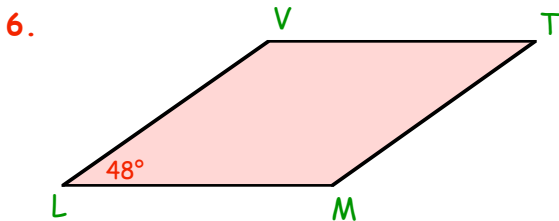
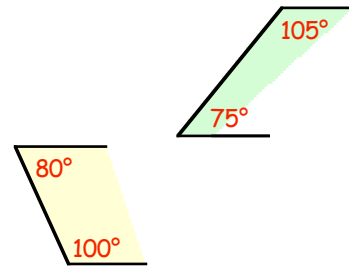

Without calculating the sizes of $\angle VTM$ and $\angle TML$, write down the size of $\angle LVT$.

7. This time, a diagonal has been drawn. Write down the sizes of :-

- $\angle JPW$
- $\angle FJW$
- $\angle WJP$ (alternate (or z) angles ?)
- $\angle PWJ$.

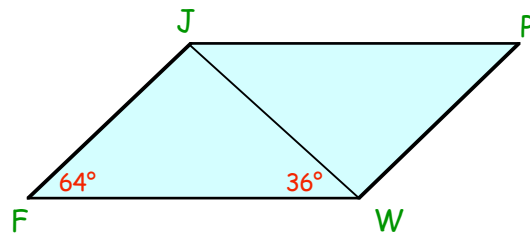

8. Make a large neat sketch of each of these parallelograms and fill in the sizes of all the missing angles :-

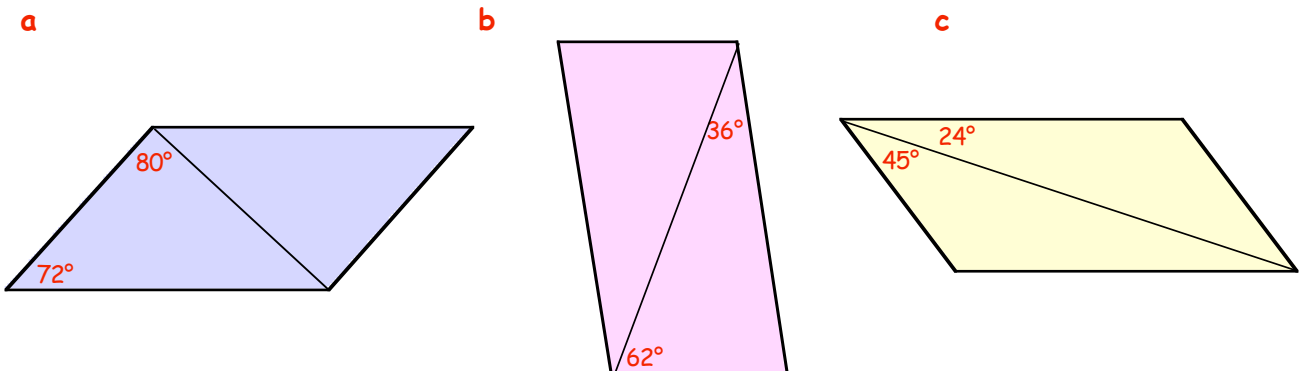

9. **Harder !!** if the 2 diagonals are drawn in, it is slightly trickier.

- a Make a large neat sketch of this parallelogram.
- b Fill in as many missing angles as you can.
- c Can you actually calculate **ALL** the missing angles ?

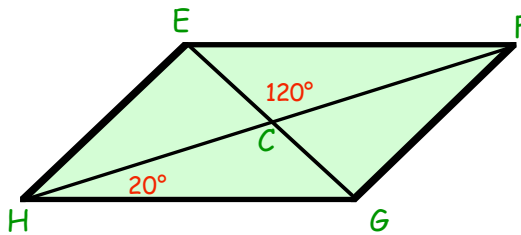

10.

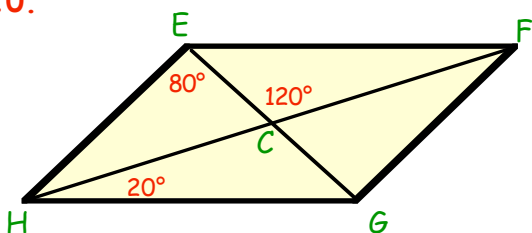

The answer to Question 9 c is "NO - not without more information".

Look at the figure now.

Now calculate the sizes of the angles you were unable to do in Question 9.

* You need to know 3 angles before you can calculate the sizes of the others - when both diagonals are shown.

11. Make sketches of these parallelograms and calculate the missing angles :-

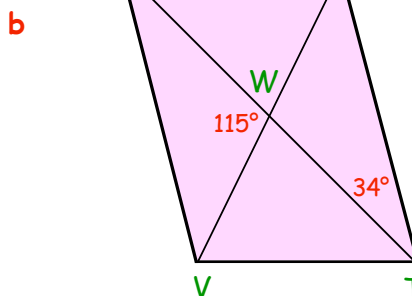
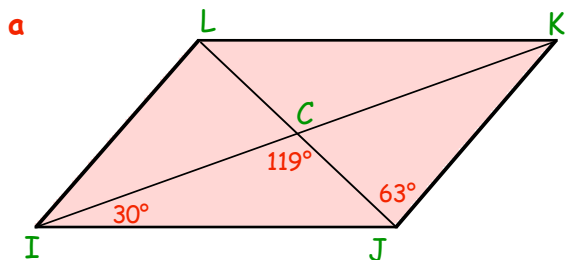

12. Shown are 2 identical parallelograms, AFEB and BEDC.

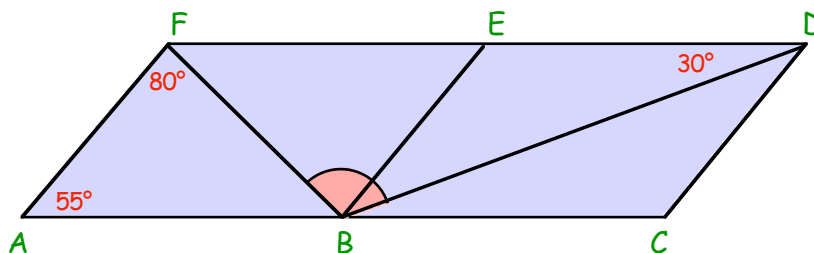

Calculate the size of the shaded angle, $\angle FBD$.

(Hint :- sketch the shape and fill in as many angles as you can)

13. Again, shown are 2 identical parallelograms.

Calculate the size of obtuse $\angle TWX$.

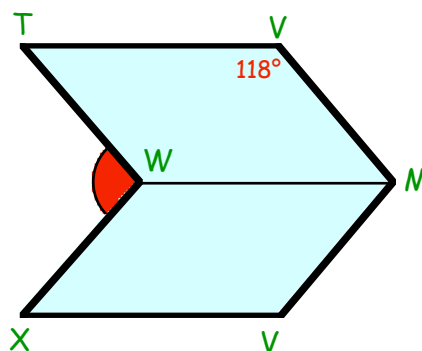

14. Shown is a square $ABCD$ and a parallelogram $BCQP$.

Calculate the size of $\angle DBP$.

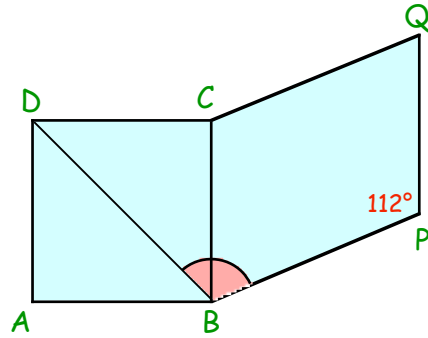

15.

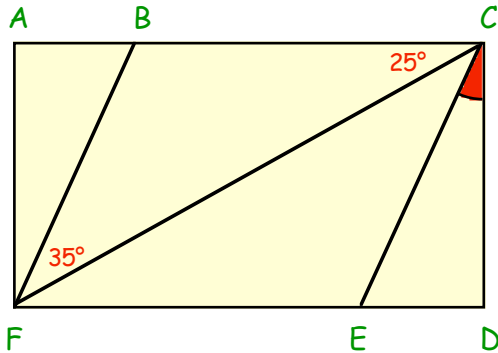

Parallelogram $BCEF$ is drawn inside rectangle $ACDF$.

Calculate the size of $\angle ECD$.

(Hint : sketch the shape and try to find as many of the missing angles as you can first)

The Trapezium

So far, you have dealt with 5 very important quadrilaterals.

Square - Rectangle - Rhombus - Kite - Parallelogram

The quadrilateral shown opposite is called a **TRAPEZIUM**.
it has only 1 **PROPERTY** — "it has 1 pair of parallel sides".

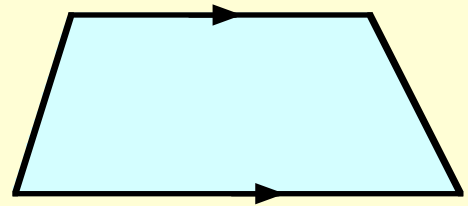

Exercise 7

1. Calculate the size of the missing angle here.

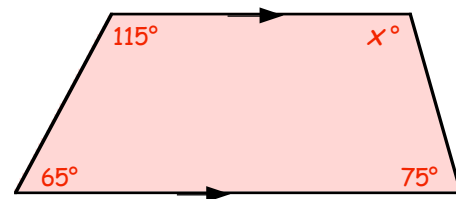

2.

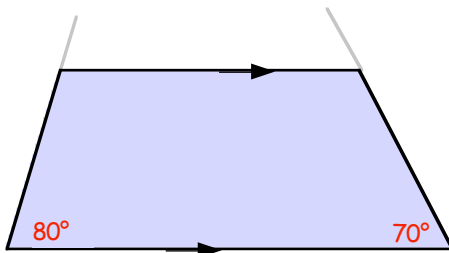

You do not need to be given 3 angles in a trapezium, 2 angles are sufficient.

What are the sizes of the 2 missing angles here?
(hint : the grey lines should help).

3. Calculate the size of the missing angles each time here :-

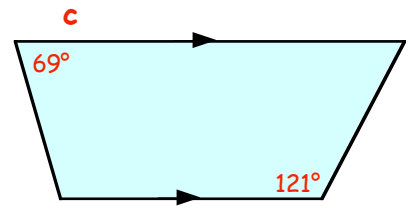
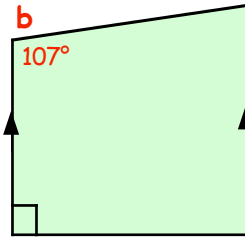
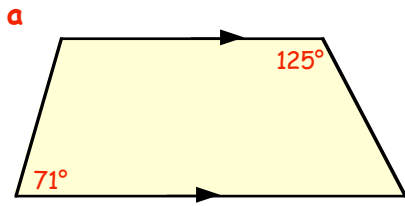

4. A "special" type of trapezium is one with 1 line of symmetry.
Sketch this trapezium and fill in the sizes of the 3 missing angles.

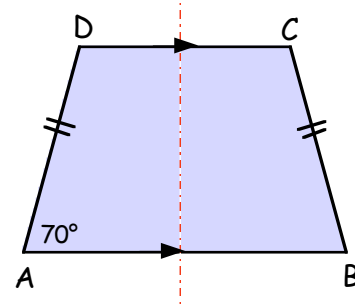

5. Each of the following are "symmetrical" **trapezia** (the plural of trapezium).
Sketch and fill in the sizes of all the missing angles :-

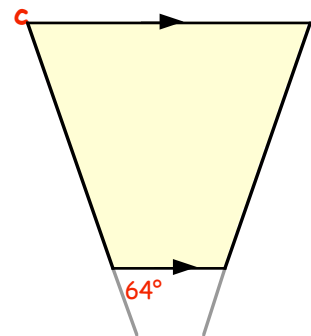
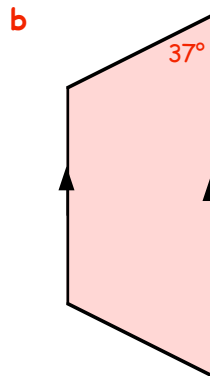
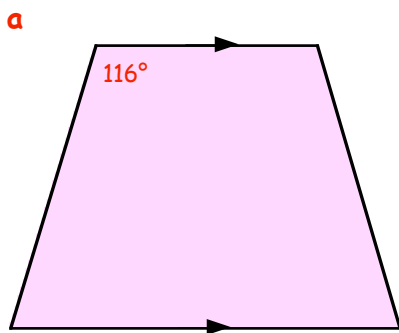

6. This trapezium is formed from an isosceles triangle.
Calculate the sizes of the four angles of trapezium ABCD.

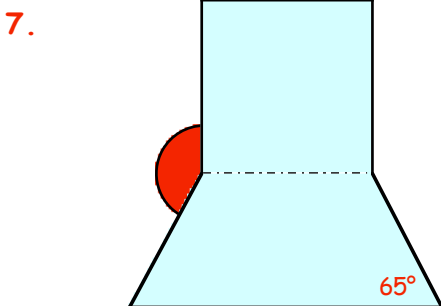
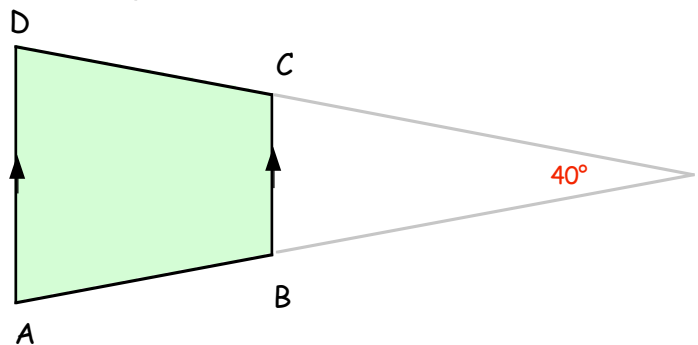

This symmetrical shape is formed from a square and a symmetrical trapezium.
Calculate the size of the shaded angle.

Topic in a Nutshell

1. Write down as many **PROPERTIES** of a **SQUARE** as you can. (minimum of 8)

2. Calculate the area of a square with sides 2.5 cm.

3. The area of this square is 49 cm^2 .

a What is the length of one of its sides ?

b Calculate the perimeter of this square.

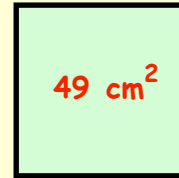

4. Write down as many **PROPERTIES** of a **RECTANGLE** as you can. (minimum of 6)

5. Calculate the area of a rectangle with sides 8 metres by 3.5 metres.

6. **Sketch** rectangle **ABCD** shown opposite.

Fill in the sizes of all the missing sides and angles.

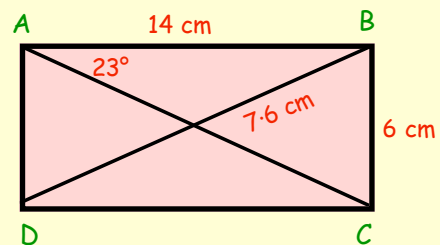

7.

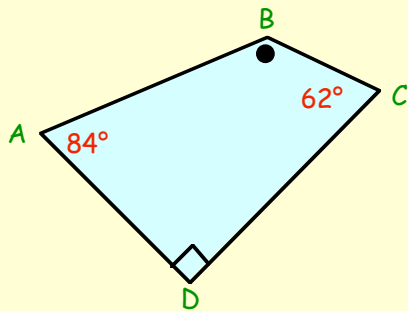

Calculate the size of $\angle ABC$ in this figure.

8. Write down as many **PROPERTIES** of a **RHOMBUS** as you can. (minimum of 6)

9. Use a ruler to make an accurate drawing of a rhombus with diagonals 12 cm and 4 cm.

10. Sketch this rhombus **PQRS** and fill the sizes of all the missing sides and angles.

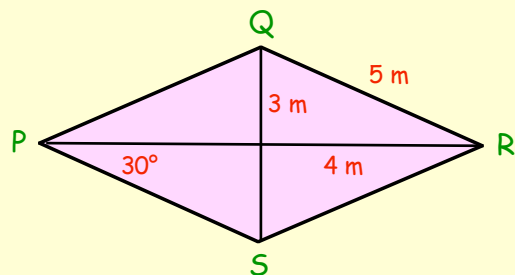

11. Write down as many **PROPERTIES** of a **KITE** as you can. (minimum of 6)

12. Make a rough sketch of kite **KLMN** and enter :-

a the length of **LM** and **KN**.

b the sizes of all the missing angles.

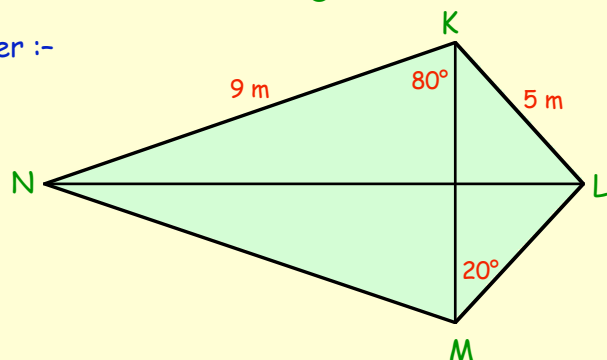

13. Use a ruler to make an accurate drawing of a kite with diagonals 10 cm and 4 cm.
14. Write down as many **PROPERTIES** of a **PARALLELOGRAM** as you can. (at least 8)
15. Sketch parallelogram **VWXY** and enter the sizes of all the missing angles.

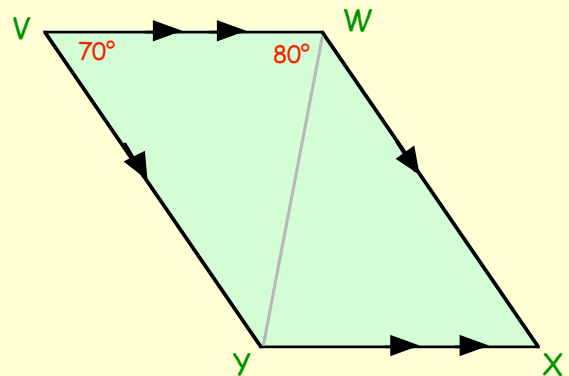

16.

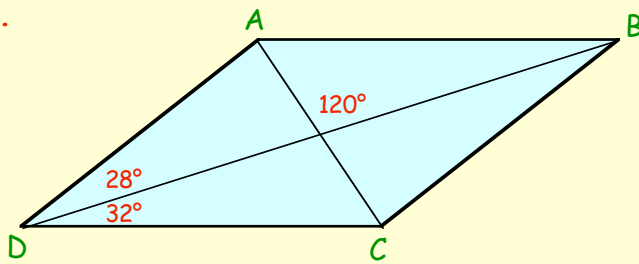

Make a sketch of parallelogram **ABCD** and fill all the missing angles.

17. Write down the single **PROPERTY** of a **TRAPEZIUM**.

18. Make a sketch of trapezium **PQRS** and enter the size of :-

- a $\angle PQR$. b $\angle PSR$.

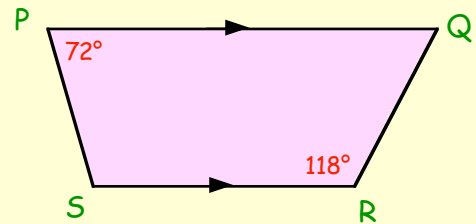

19. Copy and complete the table below.

	SQUARE	RECTANGLE	RHOMBUS	KITE	PARALLELOGRAM	TRAPEZIUM
Equal sides	4					
Sides parallel		2 pairs				
Diagonals bisect	YES					
Diagonals equal length	YES					
Opposite angles equal		YES				
Lines of symmetry		2				
Order of rotational symmetry		2				

Chapter 19

Parts of a Circle

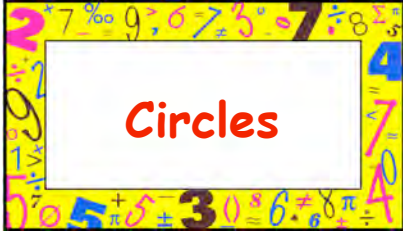

The curved distance around the edge of a circle is called the **circumference** (**C**) of the circle.

- The line joining two points on the circumference passing through the centre is the **diameter** (**D**).
- The shorter line joining the centre of the circle to the circumference is the **radius** (**R**).
- The **diameter** is always **TWICE** the **radius**.

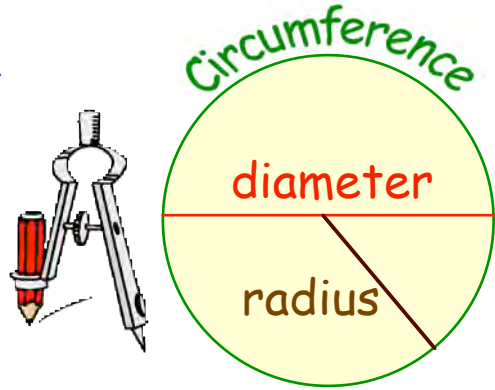

Exercise 1 (You will need a ruler and a pair of compasses for this exercise)

- Use your pair of compasses to draw a circle with a radius of 4 centimetres.
 - Draw in any diameter and label it "diameter".
 - Draw in any radius and label it "radius".
 - Put the name "circumference" around your circle.

2. For each of these circles, say whether the grey line is a radius or a diameter :-

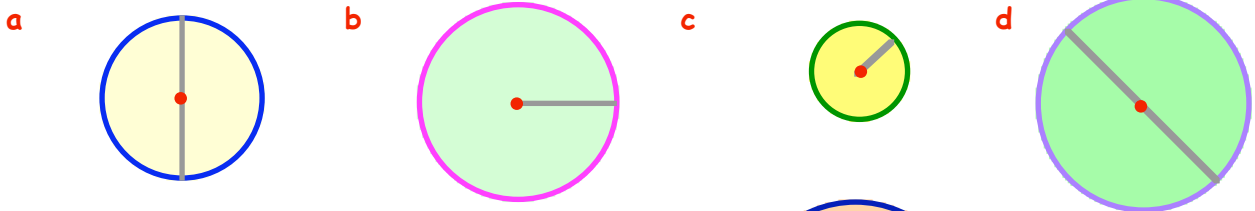

- Use two letters to name a line which is the radius of this circle.
 - Name the diameter in the figure.
 - There are 2 other radii. Name them.

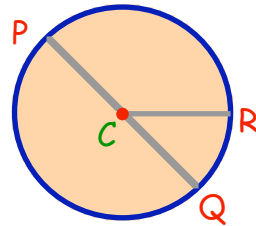

- If the radius of a circle is 15 centimetres, what is the length of its diameter ?
 - If the diameter of a circle is 50 centimetres, what is the length of its radius ?

- Use a pair of compasses, set to a radius of 4 cm, to draw this "flower" pattern. Use the dots as guides as to where to put your compass points. Colour your "petals".
- Make a display of this pattern and create some of your own.

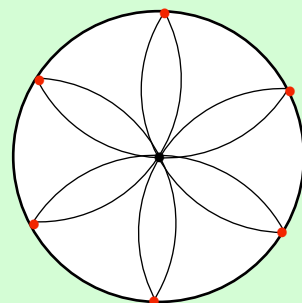

The Circumference (C) of a Circle

A long time ago it was discovered that there was a connection between the length of the **diameter** of a circle and the length of its **circumference**.

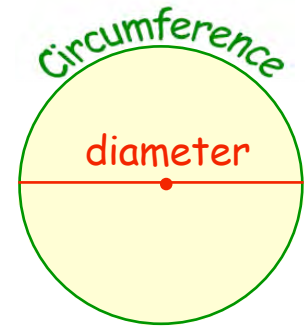

Practical Exercise

- Collect 5 or 6 circular objects, such as :- an old CD; 2 pence coin, 10p coin, bicycle wheel, toy drum, can of juice, tin of soup, tyre, plant pot, rim of a hat, watch face, battery, frisbee etc....
 - Use a ruler or a measuring tape to measure each diameter.
 - Measure each circumference using the measuring tape or a piece of string and a ruler, depending on the size of the object.
 - As you make each measurement, enter your results in your jotter using a table like the one shown below.
 - You have to use your calculator to find the answer to the 4th row by dividing the **circumference** of each circle by its **diameter**.

OBJECT	can	plate
diameter (D)	8 cm
circumference (C)	25 cm
$C \div D$	$25 \div 8 =$

COPY into you jotter



What was the nearest **WHOLE NUMBER** to your answer each time ?

Just like the ancient Egyptians, you should have found that :-

The Circumference of a circle is approximately 3 times its Diameter.

- Use the above fact, that C (approximately) = $3 \times D$ to estimate the circumference of the five circles shown below:-

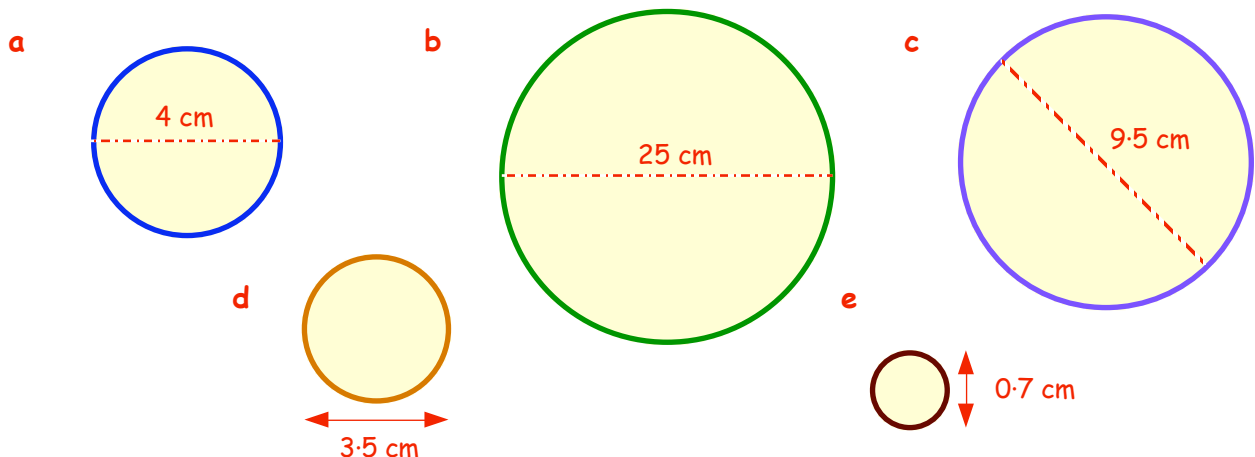

LEVEL F (Extension)

The Circumference (C) of a Circle

It has been known for a long time that when you divide the circumference of a circle by its diameter you always get the answer 3.1415927...

=> C/D = 3.14...

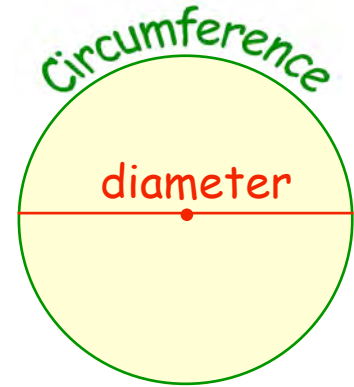

This number (3.1415927.....) is so famous in mathematics, it is given a name. It is called pi ("pi", pronounced as "pie").

=> C/D = pi (where pi is rounded to 3.14.)

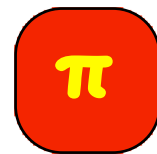

We can use the rearrangement of this to help us calculate the circumference of a circle as long as we know what its diameter is.

=> C = pi D very famous formula - to be learned !!!

Example :- Calculate the circumference of this circle which has a diameter of 14 centimetres :-

=> C = pi D
=> C = 3.14 x 14
=> C = 43.96 cm

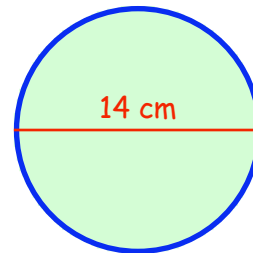

* If you have a Scientific Calculator - ask your teacher about the pi button !!

Exercise 2 (you may use your calculator here)



1. Calculate the circumference of this circle with a diameter of 5 cm.

(COPY this working) => C = pi D
=> C = 3.14 x 5 cm
=> C = cm

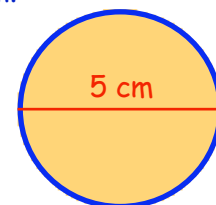

2.

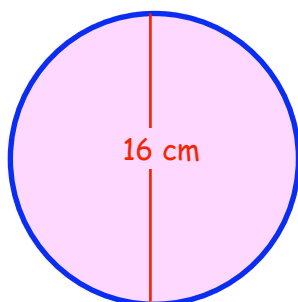

Calculate the circumference of a circle with diameter 16 centimetres.

3. For each of these circles, set down the three lines of working as shown and calculate the lengths of their circumferences :-

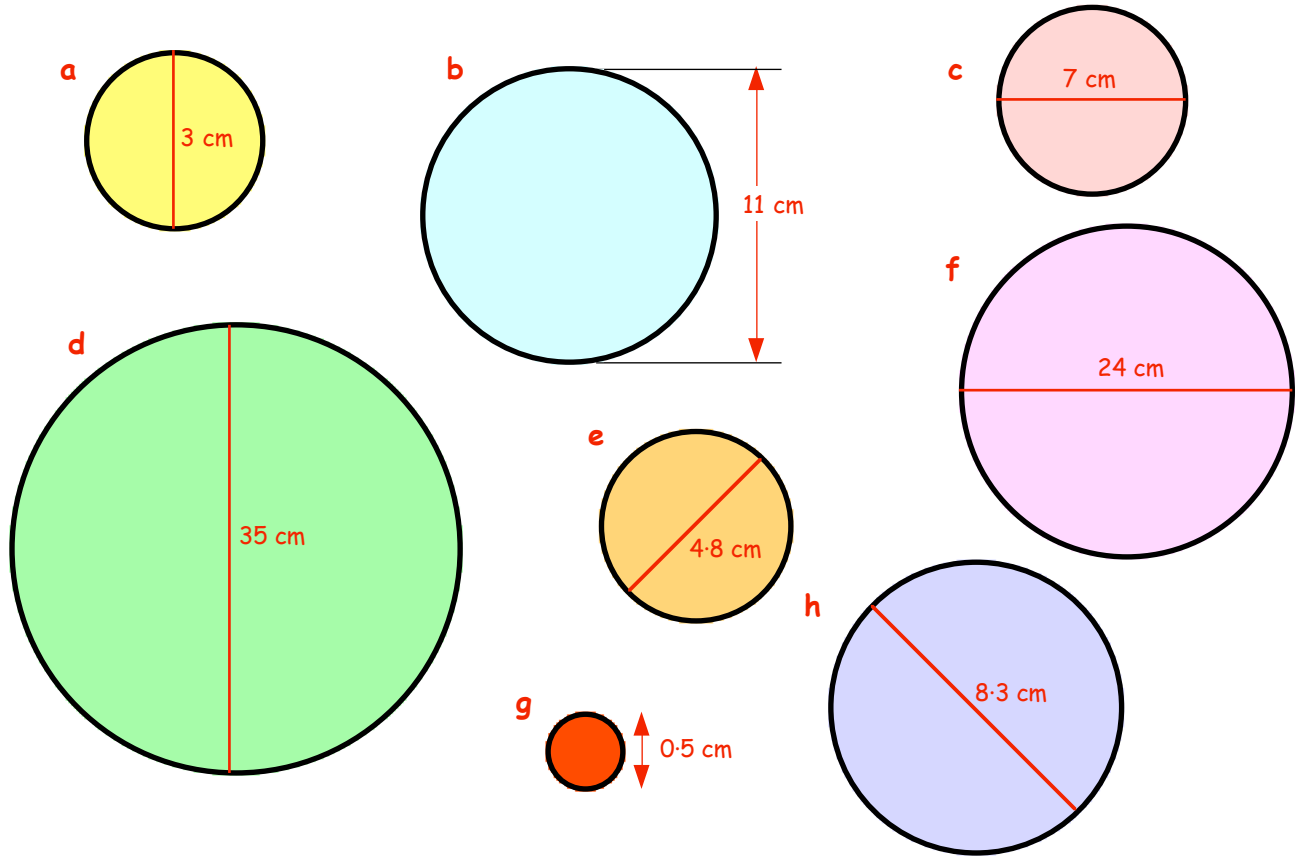

4. This dial shown opposite has a diameter of 32 centimetres.

Calculate the circumference of the dial.

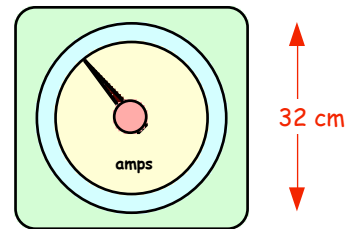

- 5.

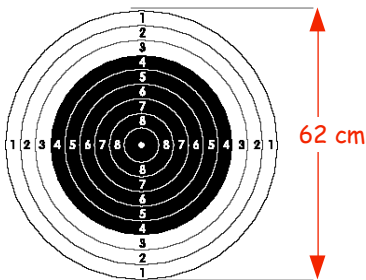

The diameter of this target is 62 centimetres.
Calculate the circumference of the target.

6. This road sign has a diameter of 50 centimetres.
Calculate its circumference.

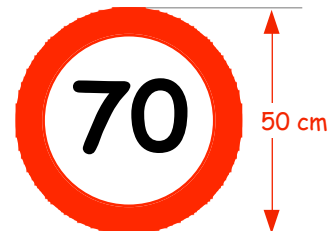

- 7.

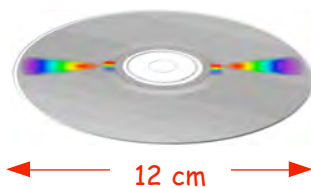

Calculate the circumference of this CD.

8. If the radius of a circle is 7 centimetres, what is the length of its diameter ?

9. For each of the following circles, (i) write down its diameter and then (ii) calculate the length of its circumference.

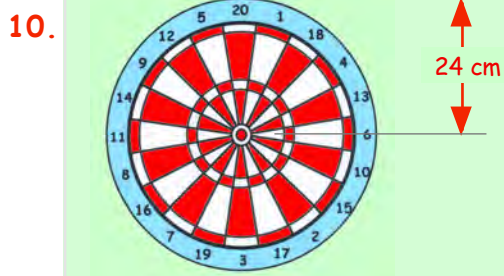
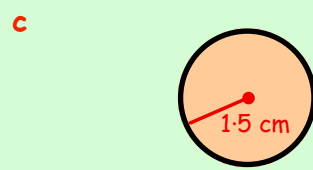
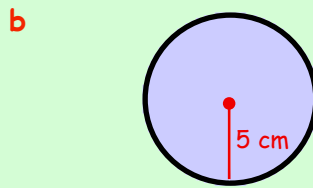
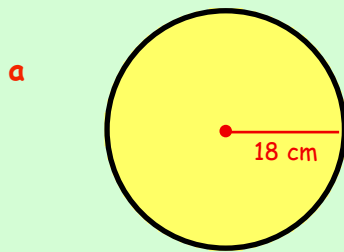

The **radius** of this dartboard is 24 centimetres.

- a Write down the length of its diameter.
- b Calculate the distance around the outside of the dartboard (the circumference).

11. This circular mouse-hole has a **radius** of 1.5 centimetres.

- a What is the diameter of the mouse hole ?
- b Calculate the circumference of the hole.

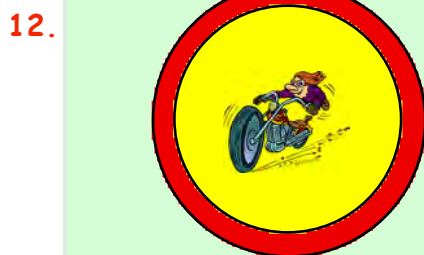

Shown is a circular motor-cycle race track. The radius of the track is 45 metres.

- a Calculate the distance round one lap of the track.
- b A motor cyclist goes around the track 25 times during a race. How far has he travelled altogether ?

13. A plastic ruler is bent into the shape of a **semi-circle** (a half circle). The diameter of the semi-circle is 19.2 centimetres. Calculate the length of the ruler.

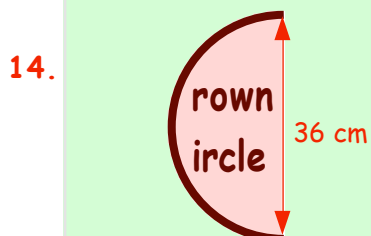
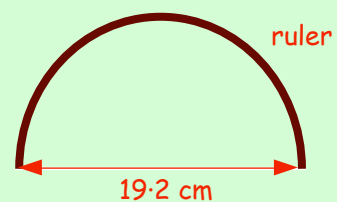

The letter C in this sign for the Crown & Circle pub is a semi-circle with a diameter of 36 centimetres. Calculate the curved length of the letter C.

15. The diagram shows a **quarter circle** with radius 10 centimetres. Calculate the length of the curved part of the shape.

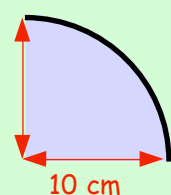

Topic in a Nutshell



1. a Name the line which is the diameter of this circle.
- b Write down any one radius. (there are 3 shown).
- c What is the special name for the perimeter of a circle ?

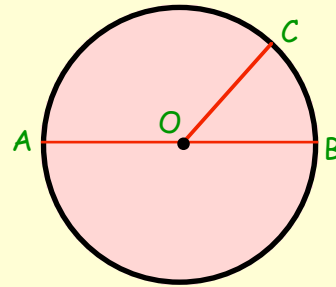

2. a The radius of a circle is 24 centimetres. What is the length of its diameter ?
- b If the diameter of a circle is 45 metres, how long is its radius ?

3. Use the formula $C = \pi D$, where $\pi = 3.14$, to find the circumference of the circle with diameter 20 centimetres.

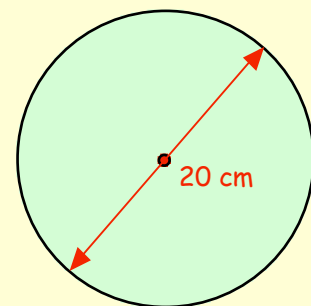

4. A circle has a radius of 22 mm.
 - a Write down the size of its diameter.
 - b Calculate its circumference.

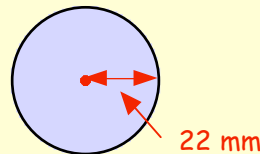

5. The diameter of this tyre is 65 centimetres.
 - a Calculate its circumference.
 - b As a car moves along a driveway, the wheel turns 20 times. Calculate how far the car travelled along the driveway. (answer in metres)



6. The radius of this plate is 15 centimetres. Calculate its circumference.

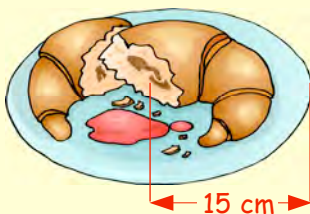

7. Use compasses to draw the following pattern as neatly as possible.
Take your time !
Colour or shade it in.

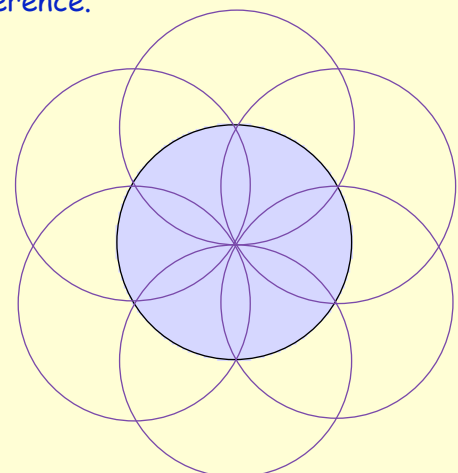

8. Design a pattern of your own using compasses.

Chapter 20

Nets of Solids

Net of a Solid

The **net** of a solid shape (like a cube) is the shape you would obtain if the cube was made of cardboard and you "opened it up and laid it out flat".

- The net of a cube**
- A cube consists 6 faces.
 - All six faces are congruent (the same).
 - Each face is a square.

Shown is a possible net of a cube with sides 2 units.

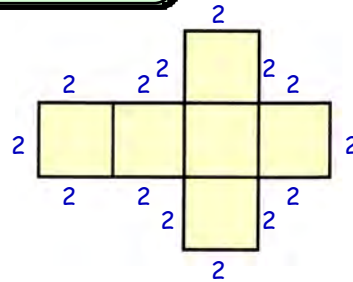
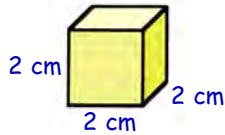

Exercise 1 Use squared paper and a ruler in this exercise.

1. Draw a full size **net** for this cube with sides 3 centimetres
2. Draw a **net** of a cube with sides 5 centimetres.
3. Shown below are shapes made up of 6 congruent squares. For each one, decide if it is the **net** of a cube or not?

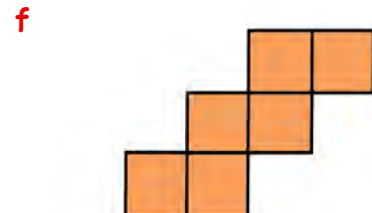
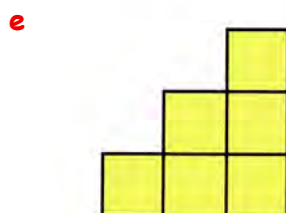
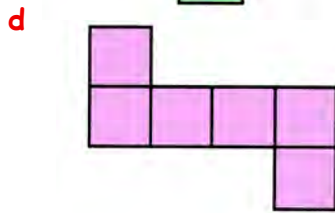
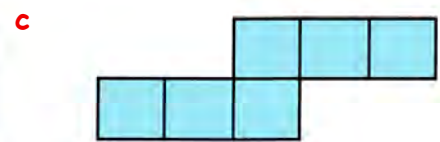
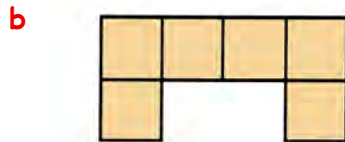
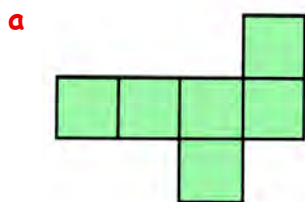
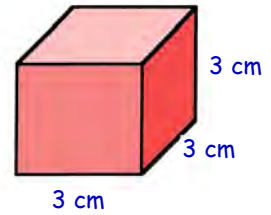

4. Design a further two nets of the cube, different from any of those found in question 3.
5. Let us look at a special family of nets of cubes. Each starts with four squares in a row.
 - a Decide on a simple rule where to put the other 2 squares so that you will always get a cube net.
 - b Say where you would **not** put the last 2 squares if you wanted a cube net.



Surface Area

Surface Area - This is the **total** area of all the faces of a solid **added together**.

Surface Area of a Cube

Since all 6 faces are identical :-

- Find the area of 1 face ($L \times L$).
- Multiply this by six.

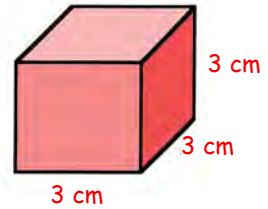

Exercise 2

1. Look at this cube with side 3 centimetres.

- Calculate the area of the front square face in cm^2 .
- Calculate the **total surface area** of the cube.

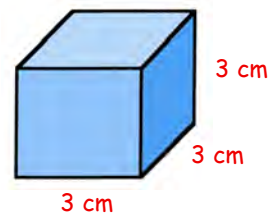

2. For each of the following cubes,

- calculate the area of the front face.
- calculate the **total surface area** of the cube.

a

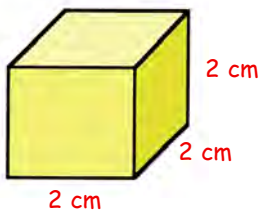

b

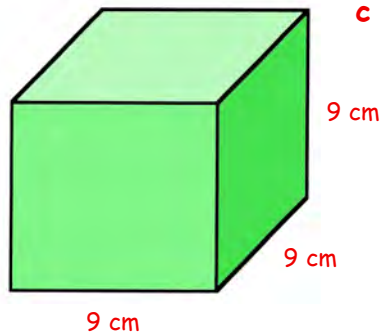

c

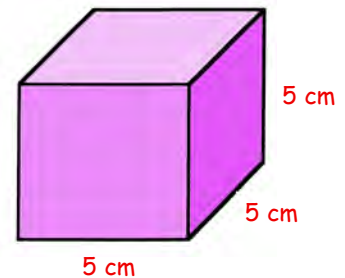

3. Calculate the **total surface area** of a cube whose sides are :-

- 4 cm
- 10 cm
- 6.5 cm
- 3.2 cm.

4. A simple formula for the surface area of a cube with sides L centimetres is

$$S.A. = 6 \times L^2$$

- Can you see why?

Use the formula to find the surface area of a cube with side (L) = 7 cm.

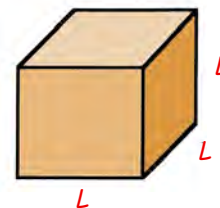

5. Use the formula $A = 6 \times L^2$ to calculate the surface area of a cube with sides :-

- 8 cm
- 1 cm
- 1.5 cm
- 4.3 cm.

The Net of a Cuboid

The cuboid consists of 6 faces but they are **NOT** all the same.

- they are not **ALL** different.
- the **front** is the same as the **back**.
- the **top** is the same as the **bottom**.
- the **right** side is the same as the **left** side.

A simple way of drawing the net :-

- Step 1 :-** Start with the front and the top.
- Step 2 :-** Complete a chain of 4 rectangles by adding on the back then the bottom.
- Step 3 :-** Now add on the right and left rectangles, one on each side.

The full size net looks like this .

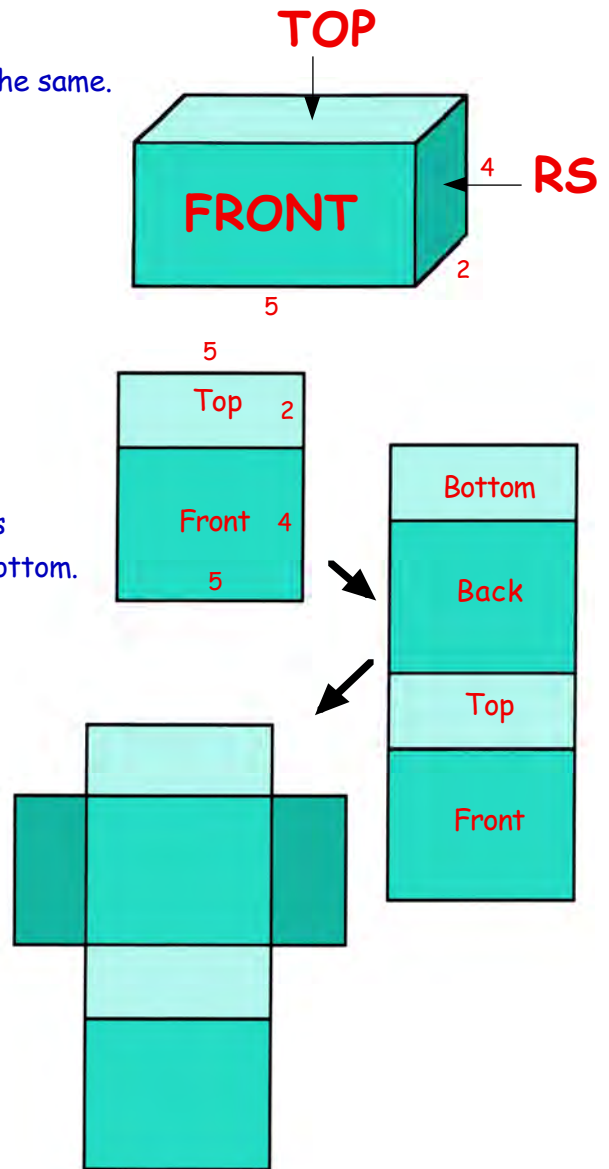
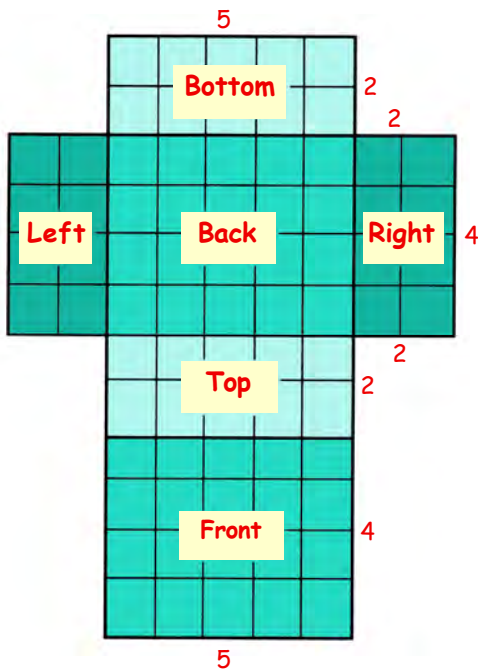

Exercise 3 (Ruler and possibly squared paper).

- Shown is the start of a net of a cuboid measuring 6 by 2 by 3.
 - Copy this carefully onto squared paper and add the back and front.
 - Now add the left and right faces.

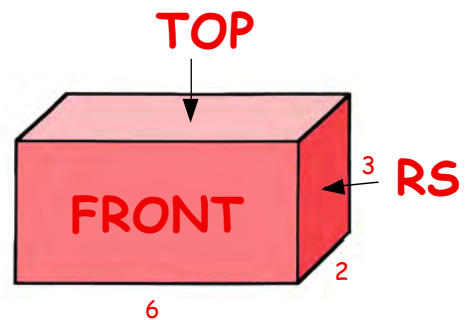
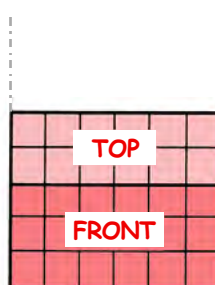

2. Neatly draw your own net of this cuboid measuring 7 boxes by 3 boxes by 4 boxes.

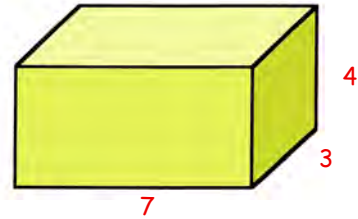

3. Neatly, using a ruler, draw nets of the following cuboids :-

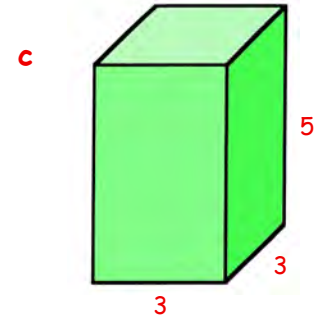
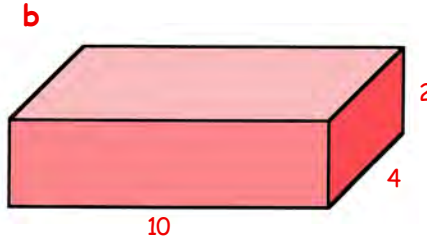
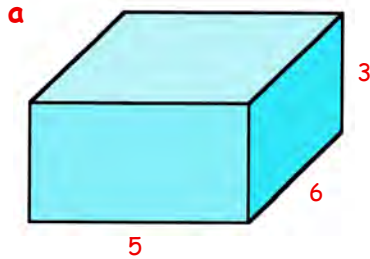

4. Make a neat sketch of the cuboid formed from the following nets (show the dimensions) :-

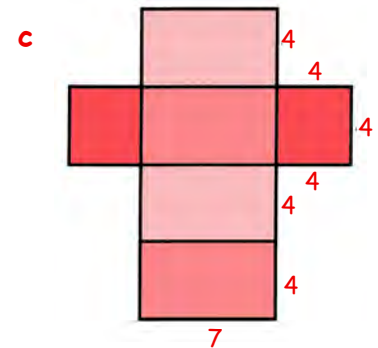
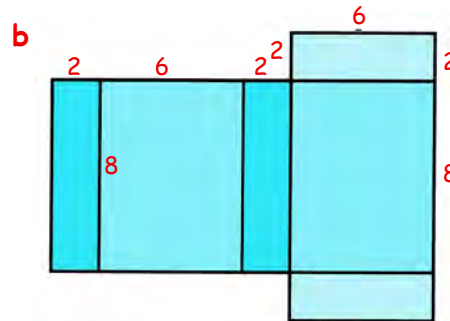
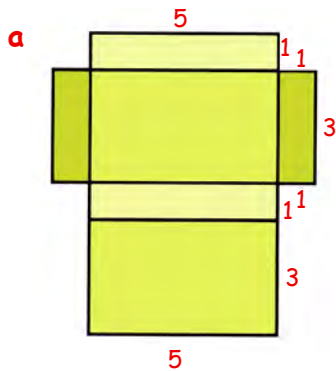

Surface Areas of a Cuboid.

The following example shows how to calculate the surface area of a cuboid.

• Area of front face =	5 cm × 3 cm =	15 cm ²
• Area of back face =	same =	15 cm ²
• Area of top face =	5 cm × 2 cm =	10 cm ²
• Area of bottom face =	same =	... cm ²
• Area of right side =	2 cm × 3 cm =	... cm ²
• Area of left side =	same =	... cm ²
Total Area =	

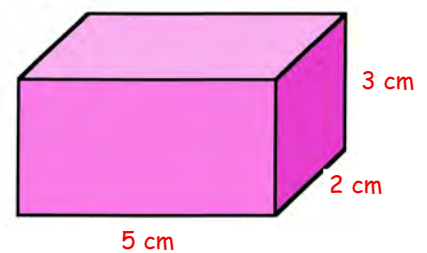

5. Copy each of the above lines and complete the calculation.

6. Calculate the total surface area of the cuboid shown opposite :-
Start with :-

- Area of **front** face = 10 cm × 2 cm = ... cm²
- Area of **back** face = same = ...



7. Calculate the total surface area of this cuboid measuring 10 cm by 7 cm by 4 cm.

- Area of **front** face = $10\text{ cm} \times 4\text{ cm} = \dots\text{ cm}^2$
 - Area of **back** face =
- etc.

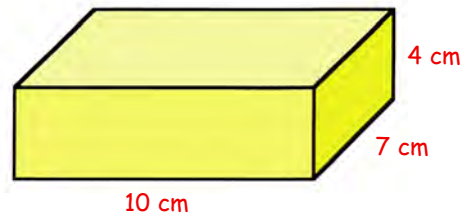

8. Calculate the total surface area of the following cuboids :-
(show your 7 lines of working)

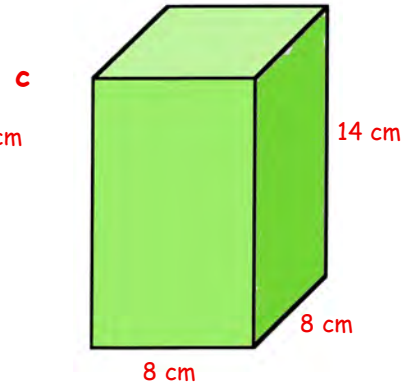
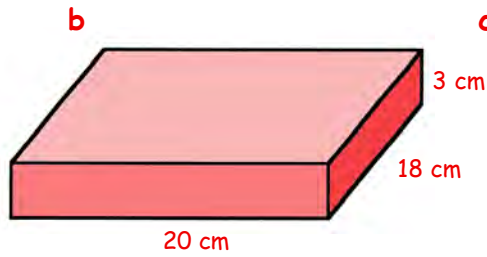
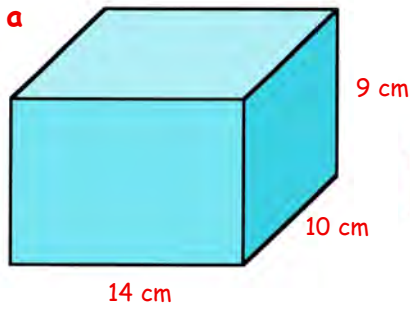

9. Shown are four pieces of card needed to make four of the six faces of a cuboid.

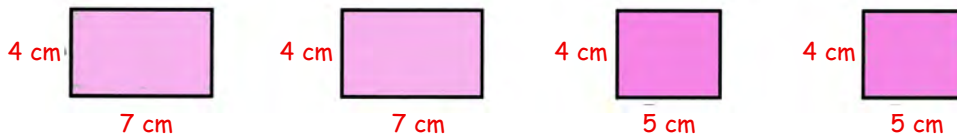

- Write down the dimensions of the other two pieces of card needed to complete the cuboid.
- Calculate the total surface area of the actual cuboid formed.

10. This time, only **two** of the six pieces of card are shown



- Write down the dimensions of the other 4 pieces of card needed to complete the cuboid.
- A special name for this type of cuboid is a "**square based cuboid**". Can you see why?
- Calculate the total surface area of the above "square based cuboid".

11. A square based cuboid has its base sides 3 centimetres long and its height 5 centimetres.

- Draw a neat accurate net of this cuboid.
- Calculate its total surface area.

The Net of a Triangular Prism

The triangular prism shown opposite consists of 5 faces but they are **not** all the same.

- the front is the same as the back. (equilateral triangles).
- the three "wrap-around" faces are the same (rectangles).

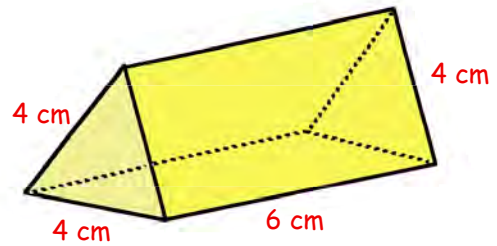

A simply way of drawing the net :-

- Step 1** Start with a strip of 3 rectangles each 4 cm by 6 cm.
- Step 2** Use compasses to draw the 2 equilateral triangles (see Ch 14).

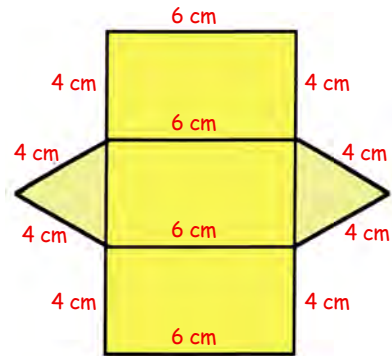

Exercise 4 (You will need a ruler and a pair of compasses).

1. Draw a **full size** net of the above triangular prism.
2. Draw the net of the triangular prism shown opposite. (You might like to do it on card, cut it out and sellotape it together to make the prism.)

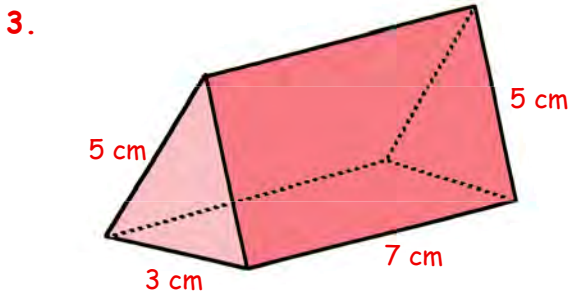
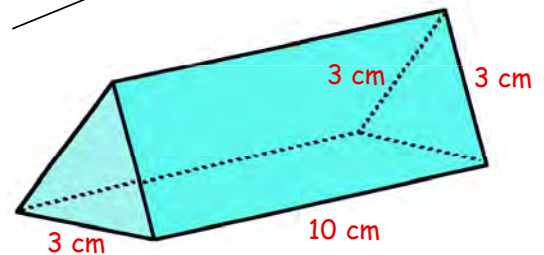

This triangular prism has its end faces in the shape of isosceles triangles.

- a Write down the dimensions (the length and breadth) of each of the three rectangular faces.
- b Make an accurate drawing of its net, using a ruler and pair of compasses.

4. A rough sketch of the net of this right angled triangular prism is shown opposite.

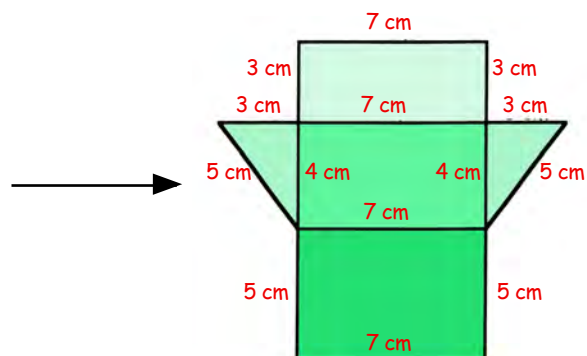
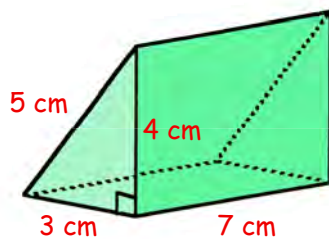

- a Make an accurate drawing of the net.
- b Calculate the total surface area of the prism.

Topic in a Nutshell

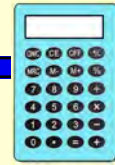

1. Draw a net of a cube with sides 4 centimetres.

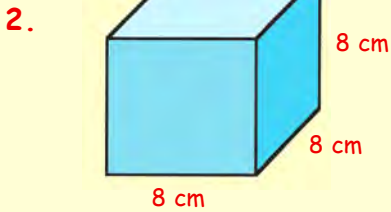
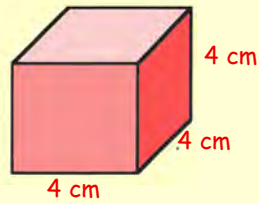

For this cube of sides 8 cm,

- a calculate the area of its front face.
- b calculate its total surface area.

3. Shown is part of the net of a cuboid measuring 5 boxes by 3 boxes by 2 boxes.

- a Copy this onto squared paper and add on the **back** and **bottom**.
- b Now put on the **left** face and the **right** face.

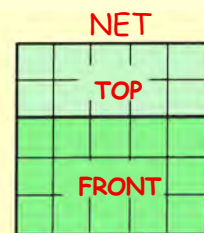
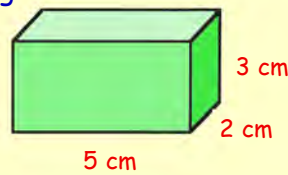

4. Draw a net of this cuboid.

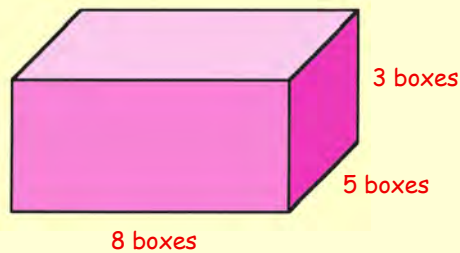

5. Draw a neat sketch of the cuboid formed from this net.

Mark on your drawing the dimensions of its sides.

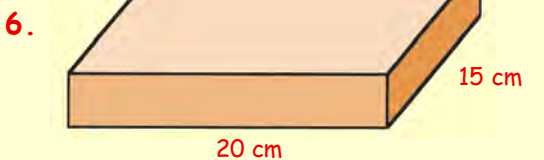
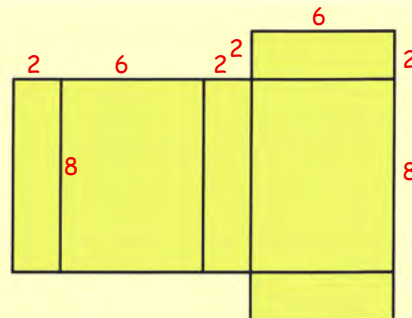

By calculating the area of each individual face, find the total surface area of this cuboid.

7. Draw the net of this triangular prism shown opposite, marking in the sizes of all the sides of your net.

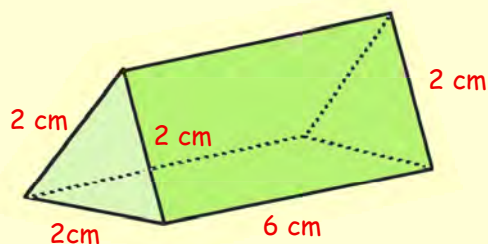

answers to LEVEL E

Answers to Chapter 0

- a. twenty three thousand and ninety
b. sixty thousand two hundred and eighty
c. nine thousand and three
d. ninety eight thousand and twenty six
- a. 42018 b. 89300
- 19000, 19099, 19780, 20009, 20105, 21000
- 6 thousand
- a. 197500 b. 71900
- a. 15 b. 7 c. 75
- 6·37
- a. 0·17 b. 0·68 c. 0·09
- 217cm, 2·17m
3m 6 cm, 306cm
1m 85cm, 1·85m
- a. £5·52
b. £5 note, 50p and 2p piece
- a. 100 b. 62 c. 104 d. 14
e. 560 f. 170 g. 184 h. 140
- a. 5796 b. 43·88 c. 7831 d. 6·37
- a. 91 b. 24 c. 40 d. 920
- a. 230 b. 34000 c. 10200 d. 63·1
e. 2·52 f. 63 g. 6·5 h. 120
- a. 20·65 b. 138·08 c. 2·61 d. 0·12
- a. 70 b. 400 c. 4130 d. 20
- a. 300 b. 2600 c. 15900 d. 7000
- a. 7 b. 30 c. 700 d. 230
- a. 60 b. 80 c. 2100 d. 84
- a. 1200 b. 120 c. 1200 d. 270
- a. 10, 12, 14 b. 21, 23, 25
c. 15, 18, 21 d. 10, 5, 2·5
e. 16, 32, 64 f. 19, 23, 27
g. 33, 39, 45 h. 72, 65, 58
- 55, 89, 144, 233
- multiply its length x 4
- a. 10·6cm, 10cm 6 mm, 106mm
- a. 40kg b. 160cm c. 200ml
- a. 0715 b. 1455 c. 2345
d. 2105 e. 0005 f. 1245
- a. 9·45am b. 4·20pm
c. 10·55pm d. 12·10am
- a. 9·20pm b. 6hr 35mins
- a. 30cm b. 38cm c. 70cm d. 12·9cm
e. 70cm f. 56cm
- a. 15cm² b. 18cm²
c. 20·5cm²
- a. drawing b. 12cm² c. 6cm²
- a. 5cm² b. 12cm²
- a. cube b. pyramid
c. sphere d. cuboid
e. cone f. triangular prism
- a. 6 b. 5 c. 2 d. 5
- a. 5 b. 6 c. 8
- a. pentagon b. hexagon
c. equilateral triangle
d. isosceles triangle
- a. circumference b. diameter
c. radius
- a. cube b. triangular prism c. pyramid
d. cuboid e. cone f. cylinder
- check compass points
- North East
- A(5,3) B(0,2) C(4,0)
- a. 2 b. 3 c. 1 d. 6
- see figures
- see figures
- a. 44·45° b. 123·125°
- a. acute b. obtuse
c. right d. straight
- see figure showing $\angle CAB = 55^\circ$
- a. b. see figures
- a. 050° b. 110° c. 250°
- a. 60 b. 154 c. Thurs d. Fridau
- a. 6 b. AP c. blue d. 6
e. TD f. NY and AY
- see bar graph
- a. 1/4 b. (i) 80 (ii) 20

Answers to Chapter 1

Ch 1 - Ex 1

- a. 600 b. 40 c. 5 d. 20000
- a. 800 b. 80 c. 8000 d. 800000
- a. two thousand and seventy
b. thirty one thousand four hundred
c. sixty thousand eight hundred and fifty

- d. one hundred and twenty three thousand and ten
- e. eight hundred and six thousand four hundred and ninety
- f. one million three hundred and twenty thousand
- g. two million eighty five thousand and sixty
- h. thirteen million and seventy five
- a. 6407 b. 19088 c. 40063 d. 109245
e. 680020 f. 2109000 g. 10080060
- a. 7897, 7978, 7987, 8009, 8079, 8090, 8097
b. 90999, 98797, 99875, 100088, 100650, 101000
- a. 920 b. 10010 c. 9950 d. 9940
e. 141600 f. 999500
g. 920001 h. 1810000
- a. 670 b. 4900 c. 6200 d. 1360
e. 1640 f. 3800 g. 8200 h. 12500
i. 13100 j. 85000 k. 97500 l. 115000
m. 145000 n. 440000
o. 530000
- a. 125 b. 1550 c. 22200 d. 240000
e. 20000 f. 64200
- a. 1000000 b. 500000
c. 250000 d. 750000
- 950000
- £30500
- £5000000000

Ch 1 - Ex 2

- a. 65 b. 120 c. 94 d. 146
e. 25 f. 15 g. 27 h. 51
i. 450 j. 910 k. 900 l. 1710
m. 530 n. 380 o. 580 p. 710
q. 60 r. 30 s. 240 t. 170
u. 8800 v. 8600 w. 2500 x. 3100
- a. 62 b. 410 c. (i) £1560 (ii) £180
d. 1400 e. £5800 f. £610 g. £14600
- a. 481 b. 663 c. 1072 d. 1635
e. 452 f. 6859 g. 8886 h. 1998
i. 168 j. 12849 k. 4051 l. 1151
m. 4163 n. 14112 o. 1419 p. 5602
q. 4761 r. 1002 s. 10144 t. 5150
- a. (i) 16197 (ii) 1341
b. 15225 c. £14610 d. 3810ft e. £5725

Ch 1 - Ex 3

- a. 190 b. 120 c. 370 d. 930
e. 1170 f. 2050 g. 3460 h. 18500
i. 20600 j. 28750 k. 543210 l. 230500
- a. 2600 b. 5800 c. 12200 d. 30000
e. 405000 f. 100600 g. 950000 h. 8060000
- a. 17000 b. 213000 c. 360000 d. 930000
e. 400000 f. 1240000
g. 3800000 h. 52020000
c. 21400
- a. 1300 b. 2700 c. 21400
- a. 7000 b. 23000 c. 320000 d. 3005000

Ch 1 - Ex 4

- a. 18 b. 26 c. 48 d. 123
e. 760 f. 4020 g. 6930 h. 5100
i. 1000 j. 14300 k. 20000 l. 505050
- a. 9 b. 17 c. 52 d. 160
e. 80 f. 1050 g. 200 h. 14000
- a. 7 b. 29 c. 78 d. 30
e. 265 f. 370 g. 900 h. 3100
- a. 13 b. 370 c. 1200
- a. 15 b. 56 c. 160 d. 1000
- a. 7 b. 6 c. 5

Ch 1 - Ex 5

- a. 2244 b. 1480 c. 3663 d. 4972
e. 21182 f. 41736 g. 54420 h. 88884
- a. 4072 b. 5719 c. 3816 d. 10824
e. 43778 f. 10185 g. 18684 h. 29961
- a. 1008 b. £13050 c. 28800 d. 18864
e. 6608 f. 17400 cm²
g. 68778km.

Ch 1 - Ex 6

- 8892
- a. 11016 b. 20928 c. 73968 d. 30580
e. 40448 f. 163674 g. 349095 h. 365376
- a. 4012 b. 20930 c. 20313 d. 74679
e. 237916 f. 419958
g. 390598 h. 525369
- a. b. 788535
c. (i) 2225686 (ii) 4024592

Ch 1 - Ex 7

- a. 544 b. 1853 c. 1239 d. 652
e. 1596 f. 2336 g. 1252 h. 985
- a. 845 b. 2376 c. 1893 d. 967
e. 966 f. 1579 g. 1451 h. 2187
i. 762 j. 719 k. 484 l. 567
m. 1512 n. 1347 o. 837 p. 869
- a. 115 b. 681 c. £587 d. 944
e. 337 f. 363 g. 726
- a. 3567r1 b. 462r4
c. 580r2 d. 785r3
e. 64r1 f. 452r3
g. 479r6 h. 613r4
i. 740r4 d. 785r3
k. 628r3 l. 2057r1
- a. 16 b. 7
- a. 166 b. 4
- a. 22r15 b. 290r12
c. 266r17 d. 86r23
e. 177r18 f. 188r3
g. 142r1 h. 18r29
- a. A = 5, B = 1, C = 0
b. S = 2, O = 3, T = 9
c. P = 5, H = 1
- various answers

Ch 1 - Ex 8

- a. 690 b. 1240 c. 960 d. 3120
e. 2240 f. 20150 g. 36900 h. 37200
i. 80500 j. 126900 k. 86000 l. 480000
- a. 6450 b. 25950 c. 16240 d. 171600
e. 72900 f. 220920 g. 162480
- a. 91200 b. 48200 c. 73800 d. 107200
e. 206000 f. 142100 g. 172400 h. 184500
i. 426600 j. 1242000
k. 2010000 l. 1023000
m. 2492000 n. 1053000
o. 12090000 p. 21840000
- a. 1200 b. 2400 c. 72000 d. 30000
e. 60000 f. 20000 g. 720000 h. 420000
i. 2400000 j. 2400000
k. 8000000 l. 72000000
- a. 50 b. 60 c. 800 d. 20
e. 40 f. 2000 g. 8000 h. 81000
i. 6000 j. 420 k. 5000 l. 920
- a. 24000 b. £9000 c. 124000
d. 108000 secs
- various answers

Ch 1 - Ex 9

- a. 70 b. 70 c. 40 d. 80
e. 20 f. 110 g. 260 h. 380
i. 10 j. 110 k. 680 l. 550
m. 1840 n. 2800 o. 2100
- a. 400 b. 700 c. 900 d. 400
e. 900 f. 700 g. 1500 h. 2100
i. 7900 j. 5600 k. 18600 l. 27400
m. 18100 n. 3000 o. 19900
- a. 8000 b. 15000 c. 25000 d. 20000
e. 74000 f. 73000 g. 2000 h. 33000
i. 86000 j. 63000 k. 80000 l. 247000
m. 325000 n. 248000 o. 600000
- a. 19850 b. 19800 c. 20000
- a. 43970 b. 44000 c. 44000

Ch 1 - Ex 10

- 100 x 50 = 5000 \Rightarrow 4992
- a. 2499 b. 3553 c. 24492 d. 58429
e. 320
- a. 2500 b. 2100 c. 8000 d. 9000
e. 28000 f. 180000 g. 30 h. 100
i. 20 j. 200 k. 200 l. 30
- a. 20000g = 20 kg b. £2000
c. £8000000

Answers to Chapter 2

Ch 2 - Ex 1

- a. 0·4 b. 0·9 c. 1·4 d. 3·5
e. 6·8 f. 0·7
- see pictures
- 0·8
- a. 2·3 b. 0·6 c. 3·5
- a. 0·52 b. 0·25 c. 0·83 d. 2·34
e. 3·17 f. 0·09
- see pictures
- a. $\frac{4}{10}$ or 0·4 b. $\frac{7}{100}$ or 0·07
- a. 60 b. $\frac{6}{10}$ c. 6 d. $\frac{6}{100}$

9. a. $7/100$ b. $9/1000$
10. a. 20 b. $2/100$ c. $2/10$ d. 200
e. $2/1000$

11. a. 0-009,0-099,0-899,0-9-0-98,1-001,1-090
b. 0-007,0-008,0-067,0-076,0-077,0-090,
0-107
12. a. $5 + 7/10 + 1/100 + 6/1000 = 5 + 716/1000$
b. $7 + 6/10 + 9/100 + 3/1000 = 7 + 693/1000$
c. $5/10 + 4/100 + 8/1000 = 548/1000$
d. $20 + 2/10 + 7/1000 = 20 + 207/1000$
e. $5/100 + 6/1000 = 56/1000$
13. a. 2-9 b. 7-7 c. 7-61 d. 0-93
e. 1-34 f. 3-723 g. 2-478 h. 0-966
i. 1-595
14. 0-784
15. a. 0-18 b. 0-89 c. 1-206 d. 0-093
e. 0-004 f. 2-320 g. 0-999 h. 0-090
i. 0-009

Ch 2 - Ex 2

1. a. 3-4 b. 20-8 c. 19-8 d. 8-9
e. 1-9 f. 3-5 g. 0-02 h. 9-4
i. 24-3 j. 4-5 k. 59-75 l. 19-8
m. 6-6
2. a. 4-61 b. 11-78 c. 8-77 d. 23-55
e. 0-29 f. 0-07 g. 3-38 h. 0-48
i. 12-36 j. 3-03 k. 6-15 l. 4-86
m. 0-54

Ch 2 - Ex 3

1. a. 4-5 b. 6-8 c. 3-1 d. 0-9
e. 15-8 f. 3-0 g. 10-0 h. 0-1
i. 7-0 j. 5-6
2. a. 8-5 b. 5-8 c. 3-6 d. 1-2
e. 2-0 f. 0-7 g. 7-9 h. 0-1
i. 10-0
3. a. 3-4 b. 2-9 c. 8-4 d. 9-4
e. 5-0 f. 4-1 g. 12-9 h. 0-3
i. 0-1
4. a. 5-7 b. 10-3 c. 12-6 d. 5-6
e. 4-2 f. 5-4
5. a. 0-7 b. 0-5 c. 0-8 d. 0-8
e. 0-3 f. 0-8 g. 0-8
6. a. 8-8 b. 23-9 c. 6-1 d. 4-5
e. 4-3 f. 3-2 g. 0-2 h. 8-1
i. 2-2
7. a. 2-9m b. 1-2L c. £1455-8(0)

Ch 2 - Ex 4

1. a. 14-8 b. 9-9 c. 11-3 d. 10-5
e. 0-9 f. 0-78 g. 0-94 h. 1-1
i. 5-54 j. 7-75 k. 5-52 l. 9-15
m. 3-4 n. 7-1 o. 8-4 p. 6-8
q. 2-9 r. 3-8 s. 0-32 t. 0-51
u. 0-64 v. 0-34 w. 4-16 x. 2-39
2. a. 6-3kg b. 4-7km c. 16-3cm d. 27-1
e. 0-28L f. 10-3km
3. a. 87-8 b. 65-63 c. 101-72 d. 26-35
e. 1-82 f. 20-93 g. 101-36 h. 14-08
i. 2-68 j. 91-45 k. 30-56 l. 1-35
m. 62-3 n. 18-7 o. 17-57 p. 4-29
q. 44-81 r. 353-49 s. 17-56 t. 36-87
u. 13-3 v. 1-03 w. 3-27 x. 0-83
4. a. (i) 118-32kg (ii) 5-34kg
b. (i) $x = 8-80m$ (ii) $y = 3-83m$
c. (i) 383-96kg (ii) 401-48kg
5. a. 21-9 b.

2-92	10-22	8-76
13-14	7-30	1-46
5-84	4-38	11-76

6. a. (i) 6-522kg (ii) 11-458kg (iii) 2-123kg
b. (i) 504-42kg (ii) 772-27kg
c. 2-535L d. 0-056m e. 0-089 sec
7. a. 1-92km b. 1-853km c. 15-637km

Ch 2 - Ex 5

1. a. 28 b. 56 c. 34-1 d. 83-2
e. 118-7 f. 8-6 g. 30-9 h. 0-6
i. 198-65 j. 83-02 k. 10-06 l. 0-407
2. a. 382 b. 764 c. 107 d. 640
e. 425-6 f. 85-1 g. 4-61 h. 0-25
3. a. 1832 b. 2070 c. 3920 d. 14100
e. 917 f. 83-5 g. 1010-1 h. 900-4

4. a. 22lb b. 220lb c. 2200lb
5. a. 2534 b. 19600 c. 800 d. 4

Ch 2 - Ex 6

1. a. 1-82 b. 2-69 c. 0-484 d. 32-65
e. 1-982 f. 13-527 g. 1-402 h. 1-7
i. 0-9 j. 0-086 k. 0-04 l. 0-0043
2. a. 9-234 b. 8-6512 c. 0-648 d. 0-1904
e. 6-2 f. 8-31 g. 0-096 h. 0-002
3. a. 7-3641 b. 29-6532 c. 8-26 d. 0-7251
e. 0-42 f. 0-9 g. 0-0812 h. 0-017
4. a. 0-351g b. £7-85
5. a. 1-528 b. 0-6267 c. 0-0944 d. 0-0075
6. 0-967ml

Ch 2 - Ex 7

1. a. 17-28 b. 11-96 c. 86-5 d. 298-48
e. 325-36 f. 1081-08 g. 1368-9 h. 676-98
2. a. 46-8 b. 61-2 c. 38-2 d. 124-83
e. 163-68 f. 28-17 g. 786-8 h. 1230-78
3. a. 160-2g b. £68-75 c. 130-8L d. 0-08
e. 115-2m² f. 109-56m
g. 18-72cm

Ch 2 - Ex 8

1. a. 7-68 b. 7-36 c. 13-58 d. 11-14
e. 0-97 f. 0-12 g. 18-79 h. 6-67
2. a. 1-3 b. 5-6 c. 4-82 d. 6-34
e. 0-23 f. 15-17 g. 131-7 h. 0-09
3. a. 48-2g b. £6-42 c. 4-69km d. 1-96m
e. (i) 9-89 (ii) 5-96 (iii) 8-34
(iv) 21-25 (v) 8-45 (vi) 0-24
f. 0-36kg

Ch 2 - Ex 9

1. £94-05 2. 2-799L
3. £204-50 4. £23-10
5. £25-55 6. £8304-51
7. £21-75 8. McCurry's by 2p
9. £2-09 10. £25-25
11. 30-9 sec
12. a. £1162-65 b. £37-34
13. a. 0-85L b. 0-29L
14. 9-58m 15. 13-835kg
16. 16-66546875 metres

Answers to Chapter 3

Ch 3 - Ex 1

1. a. 0740 b. 0255 c. 0300 d. 1430
e. 1315 f. 1900 g. 0445 h. 2120
i. 0335 j. 0855 k. 1200 l. 0010
m. 1210 n. 2030 o. 0255 p. 2310
q. 2232 r. 0636 s. 2358 t. 1113
u. 1948
2. a. 2-30am b. 10-50am
c. 8-10am d. 2-35pm
e. 4-50pm f. 11-35pm
g. 1-30am h. 5-35pm
i. 8-10pm j. 5-02pm
k. 12 noon l. 6-50am
m. 3-45am n. 3-25pm
o. 11-45pm p. 9-05pm
q. 12-40am r. 5-05am
s. 11-25am t. 6-40pm
u. 10-48pm

Ch 3 - Ex 2

1. a. 3 hrs b. 2 hrs 30 mins
c. 4 hrs 30 mins d. 3 hrs 5 mins
e. 1hr 30 mins f. 5hrs 35 mins
g. 2 hrs 5 mins h. 1 hr 25 mins
i. 1 hr 15 mins j. 3 hrs 10 mins
2. a. 4pm b. 7-05pm
c. 10-20pm d. 12-40pm
e. 2-05pm
3. 3 hrs 35 mins 4. 3 hrs 37 mins
5. a. (i) 1 hr 5 mins (ii) 45 mins
(iii) 6 hrs 35 mins
b. (i) 2-30pm (ii) 3-15
6. 11 hours
7. 5 hrs 45 mins
8. a. 3 hrs 35 mins b. 0945 c. 6
9. Mick - 4 hrs 20 mins
Pat - 4 hrs 15 mins
Pat faster by 5 mins

Ch 3 - Ex 3

1. a. 8-8 b. 9-0 c. 10-6 d. 15-8
e. 20-2 f. 2-6 g. 3-3 h. 11-9
i. 0-2
2. Hartley, Bryant, Derby, Stewart, Newlands,
Dixon
3. 1 min 28-66 secs
4. 1 min 28-88 secs (British was faster)
5. 0-06 secs
6. 12 mins 59-04 secs
7. a. 5 mins 15-2 secs b. 3 mins 39-59 secs
c. 8 mins 2-05 secs d. 4 mins 0-3 secs
e. 0 mins 29-0 secs
8. a. 1 hr 15 mins 30-75 secs
b. 2 hrs 20 mins 8-1 secs
c. 0 hr 59 mins 59-99 secs
d. 3 hrs 0 mins 10-01 secs
9. 2 mins 29-92 secs
10. a. Tom b. 1-57 secs
c. 3 mins 45-50 secs
11. a. 7 mins 10-05 secs
b. 4 hrs 53 mins 35-50 secs

Answers to Chapter 4

Ch 4 - Ex 1

1. a. £82-43 b. £17-57
2. a. £21-48 b. £2-73
3. a. £153-40 b. £116
c. £37-40
4. a. £112-50 b. £91-50
5. £82-90 6. £33-75
7. a. £773-69 b. £73-70
8. a. £21-50 b. £24-13
c. £5-30 d. £165-00
9. 50p
10. £77-96 b. £141-29
11. £12-90
12. £54-59
13. compare £0-4125 with £0-425
box of 8 is better
14. small - £0-53/100g
large - £0-52/100g
larger is better deal
15. saved £5-50
16. £189 17. £21-75
18. £3-75 19. £1-20
20. £16-50 21. £204-45
22. a. £15-12 b. £27-37
c. £23-22
23. 6 kiwi and 2 grapefruit
24. 7 white and 3 red

Ch 4 - Ex 2

1. 360 euros
2. 720 euros
3. a. 144 euros b. 518-40 euros
c. 648 euros d. 2592 euros
e. 50-40 euros f. 1087 euros
4. a. 19-44 euros b. 187-13 euros
c. 68-76 euros d. 302-40 euros
e. 1260 euros f. 431-99 euro
5. £477
6. 153104 yen
7. 1861-50 HKD
8. 19932 pesos
9. 3885 AD
10. a. \$554-91 b. 502-56 euro
c. 26311-11 rupees d. 157-33 SF
11. cheaper by 32-91 AD
12. a. Germany by 16-56 euros
b. America by \$32-91
c. Italy by 1130 euros

Ch 4 - Ex 3

1. £300 2. £65-97
3. a. £2000 b. £150
c. £277-78 d. £128-47
e. £41-67 f. £20-49
4. £364-58
5. a. £20-14 b. £2-22 c. £31-25 d. £83-30
e. £329-86 f. £868-06
6. £264-15 7. £88
8. a. 40 litres b. (i) 420 (ii) £33-84
9. No - £1-50 short
10. 47-4 rupees
11. a. Pedro - 36-542 pesos
Kylie - 5-439 dollars
b. Pedro £2-20/km Kylie £2-10/km

Answers to Chapter 5

Ch 5 - Ex 1

- a. 4°C b. -4°C c. -7°C d. -9.5°C
e. 14°C f. -6°C g. -17°C h. -25°C
- a. $-\pounds 35$
b. (i) $\pounds 18.80$ in the bank
(ii) overdrawn by $\pounds 27.74$
(iii) overdrawn by $\pounds 125$
(iv) zero money in the bank
c. $-\pounds 5.00$ d. $-\pounds 25$ e. $-\pounds 60.00$ f. $-\pounds 50$
g. $\pounds 57$ h. $+\pounds 4.20$ i. $+\pounds 725$ j. $+\pounds 321$

Ch 5 - Ex 2

- see diagrams
- a. 15°C b. 6°C c. 22°C d. 6°C
e. 6°C f. 2°C g. -8°C h. 10°C
i. -5°C j. -22°C k. -21°C l. -21°C
m. -8°C n. -5°C
- a. 4°C up b. 7°C down
c. 11°C down d. 7°C up
e. 4°C down f. 11°C up
g. 10°C down h. 12°C down
i. 60°C up j. 15°C down
- -13°C
5. 32°C
- 50°C
- a. 3°C b. -1°C c. -5°C d. -17°C

Ch 5 - Ex 3

- a. 13 b. 12 c. 5 d. 2
e. 4 f. 0 g. -2 h. -6
i. -11 j. 3 k. 0 l. 21
m. -7 n. -5 o. -5 p. -15
q. -12 r. -20 s. -9 t. -2
- a. 2 b. 0 c. 6 d. -5
e. -9 f. -10 g. -11 h. -8
i. -14 j. -20 k. -20 l. -23
m. -20 n. -39 o. -300 p. -100
- a. 11 b. -4 c. -7 d. 10
e. -10 f. -2 g. -12 h. -50
i. 15 j. -19 k. -19 l. -21
m. 15 n. -15 o. 0 p. -32

Ch 5 - Ex 4

- B(5,3) C(3,-2) D(-4,-1) E(0,3) F(-1,-3)
G(-3,0) H(5,-3) I(0,-2)
- see diagrams
a. kite b. parallelogram
c. isosceles d. rhombus
e. pentagon f. hexagon
- a. see diagram b. (-3,-3)
- a. A(1,1) B(5,1) C(5,3)
b. (1,-1) (5,-1) (5,-3)
c. (-1,-1) (-5,-1) (-5,-3)
- a. see diagram b. trapezium
c. d. (2,-1) (3,-5) (5,-5) (6,-1)
- a. see diagram
b. (0,1) (1,6) (4,7) (5,2)
c. (0,-1) (-1,-6) (-4,-7) (-5,-2)
- see figure formed

Answers to Chapter 6

Ch 6 - Ex 1

- a. $1/2$ b. $3/4$ c. $1/3$ d. $3/5$
e. $5/8$ f. $9/12$ g. $2/3$ h. $2/6$
i. $5/6$ j. $7/8$
- a. any 3 shaded b. any 2 shaded
c. any 9 shaded d. any 8 shaded
e. any 7 shaded
- a. $1/4$ b. the same
- $1/2, 1/3, 9/15, 3/6, 3/5, 3/9,$
a. $1/2 = 3/6$ b. $1/3 = 3/9$
c. $9/15 = 3/5$
- a. $6/8$ b. $9/12$
c. $12/16$ $15/20$ $18/24$ $21/28$
- a. $2/6$ b. $6/10$ c. $4/14$ d. $14/16$
e. $18/20$ f. $34/40$
- a. (i) $1/2$ (ii) $2/5$ (iii) $7/8$
(iv) $5/9$ (v) $3/13$ (vi) $6/11$

- (i) $2/3$ (ii) $3/4$ (iii) $1/5$
(iv) $5/6$ (v) $7/8$ (vi) $4/7$
- (i) $1/3$ (ii) $2/5$ (iii) $9/16$
(iv) $7/10$ (v) $9/11$ (vi) $20/21$
- a. $3/4$ b. $1/5$ c. $1/3$ d. $1/3$
e. $2/5$ f. $4/5$ g. $3/5$ h. $1/5$
i. $1/3$ j. $7/10$ k. $2/3$ l. $5/8$
m. $2/3$ n. $2/7$ o. $5/21$ p. $3/4$
q. $5/8$ r. $3/4$ s. $3/5$ t. $4/5$

Ch 6 - Ex 2

- a. 11 b. 4 c. 6 d. 10
e. 9 f. 20 g. 20 h. 7
i. 3 j. 7 k. 13 l. 8
- a. 52 b. 92 c. 63 d. 320
e. 240 f. 41 g. 300 h. 111
i. 23
- a. 12 b. 18 c. 10 d. 24
e. 10 f. 15 g. 42 h. 15
i. 20 j. 12 k. 54 l. 21
m. 21 n. 140
- a. 96 b. 150 c. 90 d. 240
e. 1170 f. 34 g. 280 h. 96
i. 540 j. 145 k. 560
- a. (i) 275 (ii) 165
b. (i) 292 (ii) 73
c. (i) 110 (ii) 22

Ch 6 - Ex 3

- a. $37/100 = 0.37$ b. $45/100 = 0.45$
c. $21/100 = 0.21$ d. $71/100 = 0.71$
e. $83/100 = 0.83$ f. $6/100 = 0.06$
g. $4/100 = 0.04$ h. $7/100 = 0.07$
i. $12.5/100 = 0.125$ j. $2.5/100 = 0.025$
- a. $9/20$ b. $9/10$ c. $13/20$ d. $7/10$
e. $1/4$ f. $1/2$ g. $3/4$ h. $1/5$
i. $1/20$ j. $6/25$ k. $22/25$ l. $18/25$
m. $1/10$ n. $2/5$ o. $7/20$ p. $17/50$
q. $3/5$
- a. 16% b. 75% c. 18% d. 60%
e. 85% f. 30% g. 52% h. 20%
i. 55% j. 94% k. 37.5% l. 87.5%
m. 90% n. 4%
- a. 80% b. 60% c. 48% d. 64%
e. 85% f. 70% g. 90% h. 75%
- a. $2X_1$ 60% $2X_2$ 75%
 $2X_3$ 64% $2X_4$ 75%
b. $2X_1$ 40% $2X_2$ 25%
 $2X_3$ 36% $2X_4$ 25%

Ch 6 - Ex 4

- a. $\pounds 13.60$ b. $\pounds 11.40$
c. $\pounds 4.90$ d. $\pounds 182$
e. $\pounds 611$ f. $\pounds 9.90$
g. $\pounds 1298$ h. $\pounds 6.46$
i. $\pounds 0.77$ j. $\pounds 7$
k. $\pounds 5.50$ l. 34p
m. $\pounds 4.80$ n. $\pounds 2.16$
o. $\pounds 15.50$ p. $\pounds 8.75$
- a. (i) 234 (ii) 126
b. 4.8kg c. $\pounds 288$ d. 68
e. (i) 1m (ii) 3.5m
f. 216
g. (i) 240 (ii) 360 (iii) 120 (iv) 80
h. 7150km

Ch 6 - Ex 5

- 100% = 1 50% = $1/2$ 25% = $1/4$
20% = $1/5$ 10% = $1/10$ 5% = $1/20$

$$33\frac{1}{3}\% = 1/3 \quad 1\% = 1/100$$

- see Question 1
- a. $\pounds 30$ b. 110 c. 3200
4. a. $\pounds 9$ b. $\pounds 20$ c. 40p d. $\pounds 1200$
5. a. $\pounds 8$ b. $\pounds 30$ c. $\pounds 500$
6. a. $\pounds 90$ b. $\pounds 13$ c. $\pounds 3.50$ d. $\pounds 200$
e. $\pounds 6$ f. 50p g. $\pounds 43$ h. $\pounds 0.90$
i. $\pounds 6$ j. $\pounds 260$ k. $\pounds 60$ l. $\pounds 30000$
7. 70 8. $\pounds 12$ 9. 25ml 10. 120g

Ch 6 - Ex 6

- see table
- a. $\pounds 24$ b. $\pounds 18$ c. $\pounds 18$ d. $\pounds 12$
- a. (i) $\pounds 12$ (ii) $\pounds 84$
b. (i) $\pounds 9$ (ii) $\pounds 36$
c. (i) $\pounds 0.60$ (ii) $\pounds 1.80$
d. (i) $\pounds 50$ (ii) $\pounds 100$
e. (i) $\pounds 14$ (ii) $\pounds 42$
f. (i) $\pounds 70$ (ii) $\pounds 210$
g. (i) $\pounds 3.10$ (ii) $\pounds 6.20$
h. (i) $\pounds 9$ (ii) $\pounds 27$
i. (i) $\pounds 18$ (ii) $\pounds 9$
j. (i) $\pounds 7$ (ii) $\pounds 63$
- a. $\pounds 27$ b. $\pounds 360$ c. $\pounds 2800$ d. $\pounds 36$
e. $\pounds 3$ f. $\pounds 27$ g. $\pounds 770$ h. $\pounds 24$
i. $\pounds 30$ j. $\pounds 16$
- Find 10%, half it and add your 2 answers
→ $\pounds 90$

Answers to Chapter 7

Ch 7 - Ex 1

- see diagrams
a. 1 b. 4 c. 1 d. 6
e. 2 f. 5 g. 1 h. 4
i. 3 j. 0 k. 4 l. 0
m. 1 n. 2 o. 12 p. 0
- see diagrams
- see diagrams
- a. A,B,C,D,E,J,K,L,M,Q,T,U,V,W,Y,3,4,7
b. H,I,8
c. F,G,N,P,R,S,Z,1,2,5,6,9



d. O drawn in the shape of an octagon 

- TEEJAYOK
- various

Ch 7 - Ex 2

- a,b,c,f,h,i,j,k,m,n,q,s,t
- a. H,I,N,O,S,X,Z,2,5,8,0
b. H,I,O,X,8,0
- a. No b. 90% c. $1/4$ - turn
- a. $1/4, 4$ b. $1/5, 5$
c. $1/6, 6$ d. $1/3, 3$
e. 0, 0 f. $1/4, 4$
g. 0, 0 h. $1/4, 4$
i. $1/4, 4$ j. $1/6, 6$
k. $1/5, 5$ l. $1/7, 7$
m. $1/4, 4$ n. $1/8, 8$
o. $1/12, 12$ p. $1/6, 6$
q. $1/7, 7$ r. $1/8, 8$
s. $1/2, 2$ t. $1/3, 3$
u. $1/6, 6$

Ch 7 - Ex 3

- a. b.

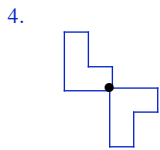
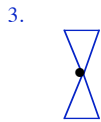
- 



5. see drawings

Ch 7 - Ex 4

- see pupils' tilings
- see pupils' tilings
- see pupils' tilings
- see pupils' tilings
- (a), (b), (c), (e), (f), (g), (h), (k), (l), (m), (n), (p), (q), (s), (t), (u), (v), (w), (x)
- see pupils' tilings
- see pupils' tilings
- see pupils' tilings
- see pupils' tilings
- see pupils' tilings

Answers to Chapter 8

Ch 8 - Ex 1

- | | | | |
|----------|----------|----------|---------|
| a. $10x$ | b. $6x$ | c. $9x$ | d. $4x$ |
| e. $14x$ | f. $12x$ | g. $3x$ | h. x |
| i. $3p$ | j. $12v$ | k. $16s$ | l. $9h$ |
| m. e | n. o | o. $2n$ | p. $3y$ |
| q. $5g$ | r. $8k$ | s. $4m$ | t. $2p$ |
| u. $6x$ | | | |
- | | |
|----------------|-------------------|
| a. $9x$ | b. $4a$ |
| c. $13v + 2$ | d. $12x + 3$ |
| e. $13w - 1$ | f. $6z + 14$ |
| g. $4r$ | h. d |
| i. $10e + 8f$ | j. $11a + 11b$ |
| k. $3x + 3y$ | l. $5v + 8w$ |
| m. $3a + 6b$ | n. $9x + 5$ |
| o. $14g + 3h$ | p. $8a + 4b$ |
| q. $6x + 7y$ | r. $2p + 5q + 16$ |
| s. $x^2 + y^2$ | |

Ch 8 - Ex 2

- | | | |
|-------|-------|-------|
| a. 23 | b. 17 | c. 90 |
| d. 1 | e. 30 | f. 0 |
- ? = 6
- | | | | |
|-------|------|------|-------|
| a. 3 | b. 4 | c. 9 | d. 18 |
| e. 54 | f. 6 | | |
- | | |
|---------------|---------------|
| a. $2x + 5$ | b. $5y - 1$ |
| c. $9a + 10$ | d. $20 - 4p$ |
| e. $3g - 15$ | f. $6d - 10$ |
| g. $2w - 5$ | h. $20 - 8x$ |
| i. $a/4 - 3$ | j. $9 - 10/p$ |
| k. $p - 1/3$ | l. $1/2s + x$ |
| m. $1/4h - w$ | n. $v - 1/5b$ |

Ch 8 - Ex 3

- | | | | |
|-------|-------|--------|-------|
| a. 7 | b. 1 | c. 12 | d. 20 |
| e. 30 | f. 60 | g. 24 | h. 6 |
| i. 14 | j. 8 | k. 1-2 | l. 1 |
- | | | | |
|-------|-------|------|-------|
| a. 13 | b. 20 | c. 2 | d. 50 |
| e. 0 | f. 10 | g. 1 | h. 36 |
| i. 64 | j. 9 | k. 1 | l. 2 |
- | | | | |
|-------|-------|-------|-------|
| a. 16 | b. 15 | c. 21 | d. 14 |
| e. 13 | f. 19 | g. 9 | h. 10 |
| i. 0 | j. 50 | k. 20 | l. 57 |
| m. 10 | n. -5 | o. 10 | p. 3 |
- | | | | |
|-------|-------|-------|-------|
| a. 18 | b. 13 | c. 14 | d. 5 |
| e. 3 | f. 5 | g. 79 | h. 6 |
| i. 9 | j. 18 | k. 2 | l. 1 |
| m. 5 | n. 0 | o. 8 | p. 12 |
- a. Cost = $(3x + 2y)$ pence
b. £1-70
- | |
|-----------------------|
| a. Length = $4p + 3q$ |
| b. 180 cm |
- | |
|-----------------------|
| a. Weight = $5f + 4s$ |
| b. 510 grams |
- | | | | |
|-------|-------|------|--------|
| a. 32 | b. 33 | c. 5 | d. 424 |
|-------|-------|------|--------|

- | |
|------------------|
| a. $P = 6x + 2y$ |
| b. 56 cm |
- | |
|--------------------|
| a. $P = 30a + 10b$ |
| b. $P = 65$ |

Ch 8 - Ex 4

- | | | | |
|------|-------|-------|--------|
| a. 4 | b. 6 | c. 7 | d. 13 |
| e. 7 | f. 23 | g. 20 | h. 50 |
| i. 0 | j. 8 | k. 1 | l. 100 |
| m. 5 | n. 5 | o. 8 | p. 35 |
| q. 3 | r. 0 | | |
- | | | | |
|--------|---------|--------|--------|
| a. 5 | b. 7 | c. 8 | d. 3 |
| e. 6 | f. 10 | g. 11 | h. 7 |
| i. 4-5 | j. 10-5 | k. 4-5 | l. 4-5 |
| m. 5-5 | n. 1-5 | o. 1-5 | p. 3-5 |
| q. 1-5 | r. 9-5 | | |

Ch 8 - Ex 5

- | | | | |
|--------|--------|------|--------|
| a. 1 | b. 5 | c. 4 | d. 8 |
| e. 5 | f. 9 | g. 9 | h. 2 |
| i. 9 | j. 10 | k. 3 | l. 7 |
| m. 7 | n. 3 | o. 0 | p. 20 |
| q. 1 | r. 2-5 | s. 5 | t. 3-5 |
| u. 4-5 | | | |
- L = $x + 5$
b. (i) $x + 5 = 14$ (ii) $x = 9$
- a. $x + 30 = 42$ b. David = 12p
- a. $x - 7 = 14$ b. marbles = 21
- Area = 4x
b. (i) $4x = 24$ (ii) $x = 6$
- | | | | |
|-------|-------|--------|--------|
| a. 14 | b. 27 | c. 80 | d. 50 |
| e. 50 | f. 96 | g. 66 | h. 100 |
| i. 7 | j. 10 | k. 18 | l. 36 |
| m. 6 | n. 10 | o. 200 | |

Ch 8 - Ex 6

- | | | | |
|------|------|------|------|
| a. < | b. > | c. > | d. < |
| e. > | f. > | g. < | h. < |
| i. < | j. > | k. > | l. > |
- | | |
|----------------|----------------|
| a. $8 < 9$ | b. $7 > 2$ |
| c. $13 < 15$ | d. $-6 > -9$ |
| e. $1 > -1$ | f. $-2 < 4$ |
| g. $-22 < -21$ | h. $-54 > -55$ |
| i. $-3 < 3$ | |
- | | | | |
|--------------|------------|--------|--------------|
| a. 3,4 | b. 0,1,2,3 | c. 3,4 | d. 0,1 |
| e. 1,2,3,4 | f. 0,1,2,3 | g. — | h. 0,1,2,3,4 |
| i. 0,1,2,3,4 | | | |
- | | | |
|-------------------|----------------|-------------------|
| a. 2 | b. -3,-2,-1 | c. -1,0,1,2 |
| d. -3,-2,-1,0,1,2 | e. -2,-1,0,1,2 | f. -3,-2 |
| g. -1,0,1,2 | h. -3,-2,-1,0 | i. -3,-2,-1,0,1,2 |
- | | | | |
|----------------|-------------|----------|--------|
| a. 4,5 | b. 1,2,3,4 | c. 0,1,2 | d. 6,7 |
| e. 1,2,3 | f. -1,0,1,2 | g. 1,2,3 | |
| h. 2,3,4,5,6 | i. 1,2,3 | | |
| j. -2,-1,0,1,2 | | | |
- | | |
|-------------------|----------------|
| a. $C \leq 38000$ | b. $y \geq 18$ |
| c. $P \leq 16$ | d. $S > 20$ |
| e. $M \geq 4$ | f. $T > 66$ |
| g. $M \geq 18$ | h. $T > 220$ |
| i. $x + y > 40$ | |

Ch 8 - Ex 7

- | | | | |
|---------------|----------------|---------------|-------------|
| a. $x > 2$ | b. $x > 5$ | c. $x \leq 1$ | d. $x < 7$ |
| e. $x \leq 9$ | f. $x \geq 31$ | g. $x > 15$ | h. $x < 70$ |
| i. $x \leq 0$ | j. $x \geq 6$ | k. $x < 1$ | l. $x > 60$ |
| m. $x < 1-1$ | n. $x > 200$ | o. $x < 1/2$ | p. $x > 2$ |
| q. $x \geq 7$ | r. $x < 4$ | | |
- | | | | |
|---------------|----------------|----------------|---------------|
| a. $x < 6$ | b. $x > 6$ | c. $x < 7$ | d. $x \geq 8$ |
| e. $x \leq 7$ | f. $x > 10$ | g. $x < 4$ | h. $x \leq 8$ |
| i. $x > 0$ | j. $x \geq 1$ | k. $x < 41/2$ | l. $x > 81/2$ |
| m. $x > 1.5$ | n. $x \leq 20$ | o. $x \geq 10$ | p. $x < 8$ |
| q. $x > 6.5$ | r. $x < 5$ | | |
- | | | | |
|---------------|---------------|-----------------|----------------|
| a. $x < 4$ | b. $x > 4$ | c. $x < 0$ | d. $x \geq 8$ |
| e. $x \leq 4$ | f. $x > 11$ | g. $x \leq 1$ | h. $x < 3$ |
| i. $x > 6$ | j. $x \geq 6$ | k. $x < 5$ | l. $x \leq 11$ |
| m. $x \geq 3$ | n. $x < 0$ | o. $x \geq 2.5$ | |

Answers to Chapter 9

Ch 9 - Ex 1

- | | | |
|---------------|-------------|--------------|
| a. 7, 6 | b. 19, 16 | c. £13, £24 |
| d. 26km, 27km | e. 7-9, 5-5 | f. 9-6, 3-93 |
- £105-68
- | | |
|---------|--------|
| a. 32-5 | b. Yes |
|---------|--------|
- | | |
|--------|-------------|
| a. 8-2 | b. 2nd last |
|--------|-------------|
- | | |
|-------|-------|
| a. 75 | b. 67 |
|-------|-------|
- | | |
|--------------|------|
| a. 6-55, 0-7 | b. 3 |
|--------------|------|
- | | |
|------------|--------------------------|
| a. 8-6, 13 | b. worms must be smaller |
|------------|--------------------------|
- Arnold's - £119 - cheaper

- Clarks - £121-60
- | | |
|--------------|------------|
| a. 21-5 mins | b. 13 mins |
|--------------|------------|
 - | | |
|---------------------|-------------------|
| a. Tenerife - £5-05 | Scotland - £13-75 |
| b. dearer by £12-70 | |
 - | | |
|-------------|-------------|
| a. 3-7 mins | b. 3-5 mins |
| c. 4-2 mins | |
 - | | |
|--------------------------|--------------|
| a. (i) 390 yds | (ii) 364 yds |
| b. $549 - 377 = 172$ yds | |
 - | | |
|----------------------|----------|
| a. (i) 258 | (ii) 296 |
| b. Yes - Mean higher | |
 - 45kg
 - 27 words
 - 16.9
 - 17.16
 - | | | |
|--------|--------|------|
| a. 500 | b. 507 | c. 7 |
|--------|--------|------|

Ch 9 - Ex 2

- | |
|--------------------------------|
| a. 4,5,2,1,6,4,1,7,5,5,1,5,1,1 |
| b. 23 |
- Pan - 6 Pet - 7 Imp - 3 Mar - 5 Ger - 3
- | |
|---------------------------|
| a. 1,2,4,7,10,6,4,0,3,2,1 |
| b. 6 |
- | | |
|----------------------|--------|
| a. 37,12,25,7,15,9,7 | |
| b. 74 | c. 112 |
- | |
|------------------|
| a. 1,2,4,9,5,0,3 |
| b. 21 |
- | | | |
|-------------------|---------|-------------------|
| a. £58 | b. £113 | c. 7pm - midnight |
| d. midnight - 5am | | |
- | | | | |
|-----------|---------|-------|--------|
| a. (i) 24 | (ii) 19 | b. 25 | c. 128 |
|-----------|---------|-------|--------|
- check labelled bar graph
- | |
|------------------|
| a. 11,3,9,7,2 |
| b. see bar graph |

Ch 9 - Ex 3

- | | | |
|--------------------|--------------|----------|
| a. noon | b. 7am - 8am | c. 2°C |
| d. 6am, 10am, noon | | e. 100°F |
- | | | | |
|--------|--------|--------|--------|
| a. Tue | b. Fri | c. Sun | d. Sun |
|--------|--------|--------|--------|
- | | |
|--------------|----------------|
| a. see graph | b. 1300 - 1400 |
|--------------|----------------|
- | |
|------------------------------------|
| a. see line graph |
| b. Mar - Apr - May (April showers) |
- | | | | |
|-------------------|-------------|------|-------|
| a. see line graph | b. 6 and 12 | c. 8 | d. 16 |
|-------------------|-------------|------|-------|

Ch 9 - Ex 4

- | | | | |
|--------|--------|--------|--------|
| a. 40% | b. 30% | c. 20% | d. 10% |
| e. 0% | | | |
- | | |
|------------------------------------|------------------------|
| a. $12\frac{1}{2}\%$ b. strawberry | |
| c. (i) 50% | (ii) 25% |
| (iii) $12\frac{1}{2}\%$ | (iv) $12\frac{1}{2}\%$ |
| d. (i) 200 | (ii) 100 |
- | | | |
|------------|------------|----------|
| a. 5% | b. (i) 40% | (ii) 60% |
| c. (i) 14 | (ii) 21 | |
| d. (i) 20% | (ii) 45% | |
| (iii) 10% | (iv) 25% | |
| b. (i) 30 | (ii) 135 | |
- | | |
|------------|------------------------|
| a. 8 | b. $12\frac{1}{2}\%$ |
| c. (i) 25% | (ii) $12\frac{1}{2}\%$ |
| (iii) 25% | (iv) $37\frac{1}{2}\%$ |
| d. (i) 40 | (ii) 60 |
- | | |
|--------------------|---------|
| a. baldy tyres - P | |
| brake light - Q | |
| exhaust - R | |
| no road tax - S | |
| b. (i) 215 | (ii) 90 |
| c. a baldy tyre | |
- see pie chart
- | | |
|--------|------------------|
| a. 10% | b. see pie chart |
|--------|------------------|
- | | |
|--------|------------------|
| a. 15% | b. see pie chart |
|--------|------------------|
- | |
|-------------------|
| a. brickies - 50% |
| joiners - 25% |
| plumbers - 15% |
| labourers - 10% |
| b. see pie chart |

Answers to Chapter 10

Ch 10 - Ex 1

- | | | | |
|-----------|------------|-------|---------|
| a. 1000 | b. 100 | c. 10 | d. 1000 |
| e. 100000 | f. 1000000 | | |
- | | | | |
|--------|-------|---------|--------|
| a. 300 | b. 70 | c. 2000 | d. 150 |
|--------|-------|---------|--------|
- | | | | |
|--------|--------|-------|-------|
| a. 200 | b. 700 | c. 50 | d. 25 |
|--------|--------|-------|-------|

- e. 75 f. 350 g. 270 h. 80
i. 146 j. 653 k. 89 l. 6
4. a. 1000 b. 4000 c. 15000 d. 500
e. 250 f. 100 g. 5600 h. 7300
i. 900 j. 1362 k. 85 l. 7
5. a. 90 b. 5 c. 35 d. 91
e. 168 f. 4 g. 127 h. 1
6. a. 5.9 cm, 59 mm, 5 cm 9 mm
b. 2.4 cm, 24 mm, 2 cm 4 mm
c. 6.4 cm, 64 mm, 6 cm 4 mm
d. 7.9 cm, 79 mm, 7 cm 9 mm
7. a. $\frac{1}{4}$ km b. 6 mm c. 180 cm d. 505 m
e. $2\frac{1}{4}$ cm f. 0.8 km
8. a. 4 b. 6.5 c. 1.75 d. 12.3
e. 0.68 f. 1.02 g. 0.04 h. 10
9. a. 5 b. 13 c. 2.5 d. 1.6
e. 2.32 f. 0.8 g. 0.75 h. 0.09
10. a. 7 cm b. 14 cm c. 11.9 cm
12. 10 cm (0.1 m)
13. a. 2.395 m b. 10
14. a. 119.55 m b. 239.1 m
c. 1195.5 m

Ch 10 - Ex 2

1. 45 cm
2. a. 26 cm b. 14.8 m c. 311 m
3. 18.6 cm
4. a. 28 cm b. 33 cm c. 46 mm
d. 60 cm e. 318 m f. 23.2 m
5. 34 cm
6. a. 9 cm b. 8.2 cm c. 58 m
7. 5 cm
8. a. 8 cm b. 22 m c. 3.1 cm
9. a. 14.6 m b. $13.8 \times \pounds 1.20 = \pounds 16.56$
10. $\pounds 189$

Ch 10 - Ex 3

1. a. 11 b. 11cm^2
2. a. 5cm^2 b. 9cm^2 c. 6cm^2 d. 10cm^2
e. 10cm^2 f. 10cm^2 g. 4.5cm^2 h. 7cm^2
i. 15cm^2 j. 12cm^2 k. 10cm^2 l. 8cm^2
m. 9cm^2 n. 16cm^2
3. a. $25 - 27\text{cm}^2$ b. $22 - 24\text{cm}^2$
c. $22 - 26\text{cm}^2$ d. $25 - 27\text{cm}^2$

Ch 10 - Ex 4

1. a. b. 18cm^2 c. 18cm^2
2. 50cm^2
3. a. 21cm^2 b. 48cm^2 c. 49cm^2 d. 91cm^2
e. 160cm^2 f. 44cm^2
4. a. 24m^2 b. 10m^2 c. 21m^2 d. 70m^2
e. 120m^2
5. a. 352m^2 b. 195m^2 c. 406m^2
d. 2250m^2 e. 1008m^2
6. $\pounds 99.45$
7. a. 150m^2 b. 10 litres
c. $\pounds 47.50 \times 2 = \pounds 95$
8. a. Area = 15cm^2 Per = 16 cm (Per- bigger)
b. Generally not true

Ch 10 - Ex 5

1. a. 45cm^2 b. 70cm^2 c. 115cm^2
2. 102cm^2
3. a. 192cm^2 b. 137cm^2 c. 160cm^2 d. 213cm^2
e. 230cm^2 f. 102cm^2 g. 119cm^2 h. 260cm^2
i. 258cm^2

Ch 10 - Ex 6

1. a. b. see drawings
c. 24cm^2 d. 12cm^2
2. a. b. see drawings
c. 24cm^2 d. 12cm^2
3. a. b. see drawings
c. 16cm^2 d. 8cm^2
4. a. 25cm^2 b. 12cm^2 c. 60cm^2 d. 60cm^2
e. 40.5cm^2 f. 160cm^2 g. 11cm^2
5. a. 18cm^2 b. 9cm^2
c. Area of triangle = $\frac{1}{2}$ area of rectangle

Answers to Chapter 11

Ch 11 - Ex 1

1. a. (2) add 3 b. (7) add 6

- c. (25) subtract 5 d. (98) subtract 17
e. (3) times 3 f. (1) $\times 6$
g. $(200) \div 2$ h. $(192) \div 4$
i. (1) $\times 4$ j. $(11\frac{1}{2})$ add $\frac{1}{2}$
k. $(5\frac{3}{4})$ subtract $\frac{1}{2}$ l. (1) double
m. (200) subtract 100 n. $(108) \div 3$
o. down 1 up 1
2. a. 15,17,19 b. 21,25,29
c. 18,16,14 d. 22,10,-2
e. 27,81,243 f. 32,64,128
g. 12,6,3 h. $1, \frac{1}{10}, \frac{1}{100}$
i. 21,26,31 j. 13,21,34
k. 13,18,24 l. 42,56,72



Ch 11 - Ex 2

1. a. 6 by 6 b. 36 c. 49
d. $10 \times 10 = 100$ e. 400
2. 64,49,81,100,900
3. a. 1,4,9,16,25,36,49,64,81,100,121,144,169,
196,225,256,289,324,361,400
b. $3^2 + 4^2 = 5^2$, $6^2 + 8^2 = 10^2$,
 $9^2 + 12^2 = 15^2$,
 $12^2 + 16^2 = 20^2$,
4. a. check drawing b. 21
c. 6 d. 7 e. 28 f. 21
g. 231 h. 253
5. a. 6 b. 10 c. 7
d. 15 e. 21
6. a. 3 b. 8 c. 1
d. 9 e. 11
7. $5^2 - 4^2 = 25 - 16 = 9 = 3 + 4$
 $6^2 - 5^2 = 36 - 25 = 11 = 6 + 5$
 $7^2 - 6^2 = 49 - 36 = 13 = 7 + 6$
 $8^2 - 7^2 = 64 - 49 = 15 = 8 + 7$
8. a. 4 b. 9 c. 16 d. 25
e. you get a square number
9. a. 5th and 6th
b. (i) $9\text{th} + 10\text{th} = 10^2 = 100$
(ii) $19\text{th} + 20\text{th} = 20^2 = 400$

Ch 11 - Ex 3

1. a. $\square \square \square \square$
b. 4,8,12,16,20,24 c. 4
d. matches = $4 \times$ squares
e. $M = 4 \times S$ f. 80
2. a. 4 starfish - 20 tentacles c. 5
b. 5,10,15,20,25,30
d. tentacles = $5 \times$ starfish
e. $T = 5 \times S$ f. $T = 5 \times 50 = 250$
3. a. 6,12,18,24,30,36
b. cost = $6 \times$ books
c. $C = 6 \times B$ (or $6B$) d. $\pounds 90$
4. a. 8,16,24,32,40,48
b. pieces = $8 \times$ half oranges
c. $P = 8H$ d. 320
5. a. 15,30,45,60,75 b. 15
c. $T = 15 \times M$ d. $180\text{min} = 3 \text{ hr}$
6. a. 9 b. $P = 9 \times N$ c. 450
7. a. $P = 50T$
b. $G = 12B$
c. $W = 110C$
d. $S = 60M$
e. $M = 220B$
f. $L = 100C$
g. $C = 9.5T$

Ch 11 - Ex 4

1. a. $\square \square \square \square$
b. 4,7,10,13,16,19 c. 3
d. $M = 3 \times S + 1$
e. $M = 31$ f. $M = 76$
2. a. 
b. 6,11,16,21,26,31 c. 5
d. $L = 5 \times H + 1$ e. 101 f. 9
3. a. 
b. 3,5,7,9,11,13 c. 2
d. $L = 2T + 1$ e. 61 f. 15
4. a. see drawing
b. 4,8,12,16,20,24 c. 4
d. $S = 4P - 4$ e. 76
5. a. see drawing
b. 3,5,7,9,11,13 c. 2

- d. $T = 2 \times S - 1$ e. 49
6. a. (i) $\pounds 17$ (ii) $\pounds 20$ (iii) $\pounds 23$ b. $\pounds 3$
c. $C = 3 \times D + 5$ d. $\pounds 47$
7. $W = 0.5 \times S + 1$
8. a. $P = 2N + 1$
b. $A = 10T + 10$
c. $S = 40P + 10$
d. $V = 7T + 8$
e. $T = 0.25C + 0.25$
f. $T = 2D - 5$
g. $S = 40D - 15$
9. 15 10. 11 cm 11. 90 miles
12. a. 395 b. 25

Answers to Chapter 12

Ch 12 - Ex 1

1. a. obtuse b. right
c. straight d. obtuse
e. reflex f. acute
g. obtuse h. acute
2. a. acute b. right
c. obtuse d. obtuse
e. acute f. obtuse
g. acute h. acute
3. obtuse - (90 - 180) reflex - (180 - 360)
straight - 180 right - 90
acute - (0 - 90)
4. a. 115,167,92,177 b. 65,87,17,51
c. 180 d. 210,325
e. 90

Ch 12 - Ex 2

1. a. $\angle RAJ$ b. $\angle EVN$
c. $\angle KSB$ d. $\angle WFP$
e. $\angle QHY$ f. $\angle UMD$
g. $\angle GXP$ h. $\angle LTC$
2. a. $\angle GSU$ - right
b. $\angle NZE$ - acute
c. $\angle AGU$ - obtuse
d. $\angle CJK$ - reflex
e. $\angle DKM$ - acute
f. $\angle EWG$ - straight
g. $\angle BUT$ - acute
h. $\angle BUD$ - obtuse
3. a. (i) $\angle DMW$ (ii) $\angle MDW$ (iii) $\angle DWM$
b. (i) $\angle RMT$ (ii) $\angle RTM$ (iii) $\angle TRM$
4. $2 - \angle BMZ$ $3 - \angle BDZ$
 $4 - \angle MBD$ $5 - \angle DZM$
5. a. $\angle FQX$ b. $\angle DQF$
6. (i) $\angle UWX$ (ii) $\angle LJT$
(iii) $\angle HWJ$ (iv) $\angle WJQ$
7. see drawings
8. a. $\angle TAP$ and $\angle APH$
b. $\angle ATD$, $\angle TDH$, $\angle DHA$, $\angle HAT$
c. 7
d. $\angle ADT$, $\angle ADH$, $\angle TAD$, $\angle DAH$, $\angle PAH$,
 $\angle PHA$, $\angle PAD$

Ch 12 - Ex 3

1. a. 360° b. 360°
2. a. 240° b. 120°
3. a. 110 b. 160 c. 90 d. 140
e. 135 f. 90 g. 90 h. 66
4. a. 180° b. 180°
5. $a + b = 180$
6. 30°
7. 143°
8. a. (i) 100 (ii) 65 (iii) 10 (iv) 179
b. 90°
9. a. 133 b. 63 c. 129 d. 144
e. 58 f. 90 g. 36 h. 60
10. a always = b
11. 37°
12. a. 122° b. 35° c. 53° d. $251\frac{1}{2}^\circ$
e. 90° f. 139°
13. a. 25° b. 155° c. 155°
14. a. 123, 57, 123, 57
b. 39, 141, 39, 141
c. 108, 72, 108, 72

Ch 12 - Ex 4

1. a. 35° , 80° , 65°
b. 180°
c. exactly

2. see drawing
 3. a. 95° b. 85°
 4. a. 50° b. 42° c. 46° d. 36°
 e. 133° f. 100° g. 33° h. 139°
 5. a. 40° b. 75°
 6. isosceles
 7. a. 38° b. 104°
 8. a. $75^\circ, 30^\circ$ b. $46^\circ, 88^\circ$
 c. $52^\circ, 76^\circ$ d. $81^\circ, 18^\circ$
 e. $60^\circ, 60^\circ$ f. $78^\circ, 24^\circ$
 g. $32^\circ, 116^\circ$ h. $69^\circ, 42^\circ$
 9. a. 50° b. 25°
 10. a. $70^\circ, 70^\circ$ b. $55^\circ, 55^\circ$
 c. $79^\circ, 79^\circ$ d. $68^\circ, 68^\circ$
 e. $73^\circ, 73^\circ$ f. $46^\circ, 46^\circ$
 g. $36^\circ, 36^\circ$ h. $20^\circ, 20^\circ$
 11. a. 55° b. 55°
 12. a. $60, 60, 60$ b. $35, 35, 110$
 c. $80, 80, 20$ d. $47, 47, 86$
 e. $86, 86, 8$ f. $50, 50, 80$
 13. a. 61° b. 61° c. 58°
 14. a.

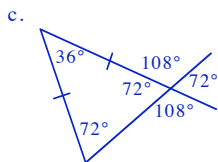
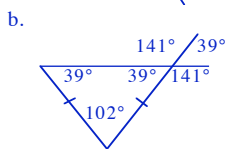
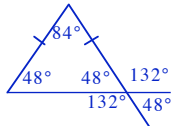

15. a. equilateral
 b. 60°

Ch 12 - Ex 5

1. a. $\angle TPQ$ b. $\angle FRV = \angle MVG$
 c. $\angle EFH = \angle FGI$ d. $\angle KLM = \angle LNO$
 2. a. c b. p c. q
 3. see diagrams
 4. a. 76° b. 52° c. 68° d. 105°
 e. 137° f. $v = 165^\circ, u = 15^\circ$
 5. a.

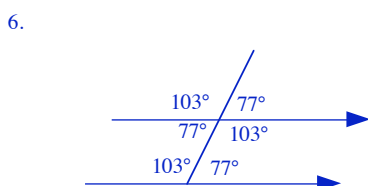
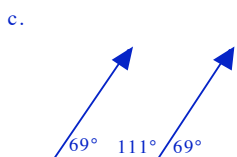
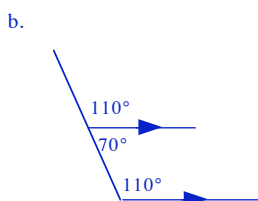
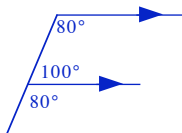

7. a.

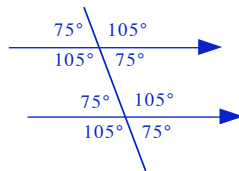

- b. 75°

8. a.

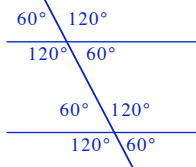

- b.

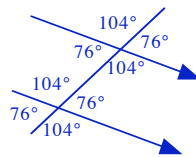

- c.

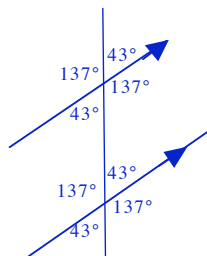

- d.

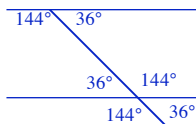

- e.

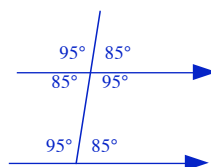

- f.

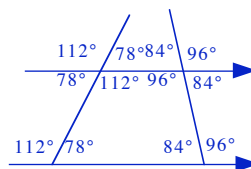

- g.

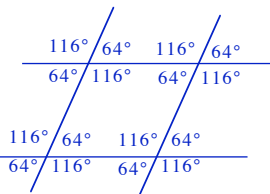

- h.

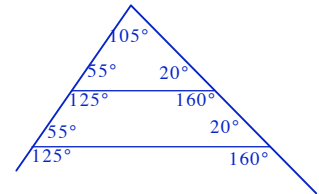

- i.

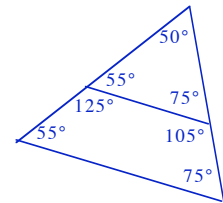

- j.

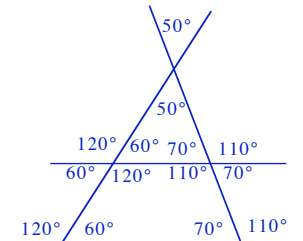

- k.

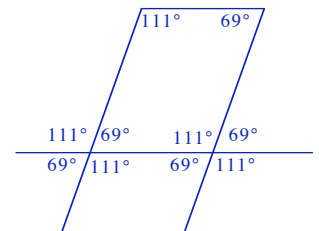

- l.

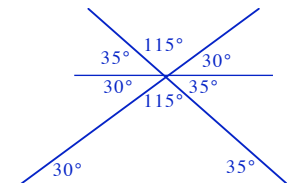

Ch 12 - Ex 6

1. see figures
 2. a. $\angle ATW = \angle TWL$
 b. $\angle ZRD = \angle RDM$
 c. $\angle TDQ = \angle DQG$
 d. $\angle SXC = \angle XCP$
 3. a. j b. p
 4. a. 25 b. 76 c. 122
 d. 33 e. 82 f. 90
 5.

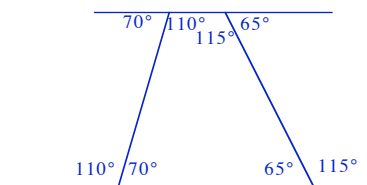

- 6.

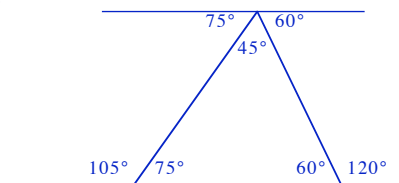

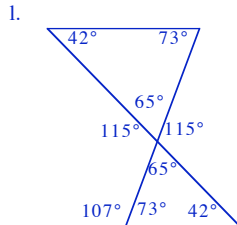
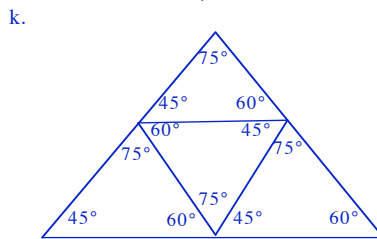
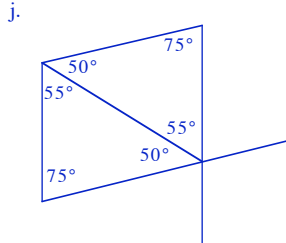
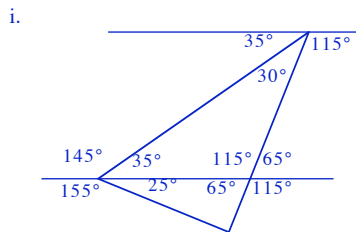
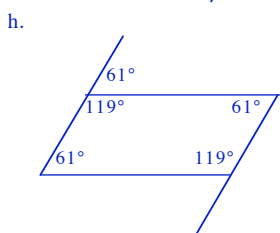
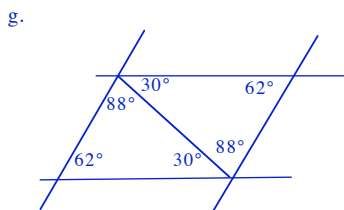
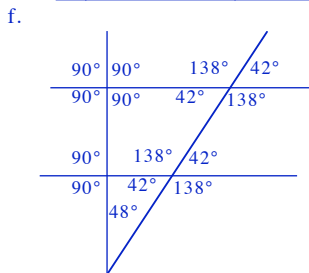
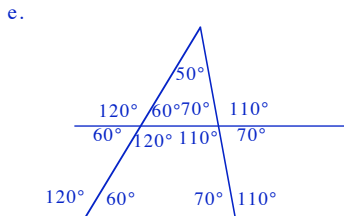
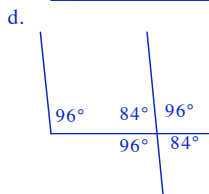
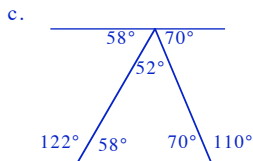
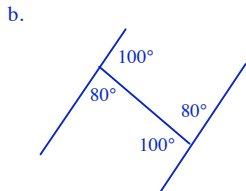
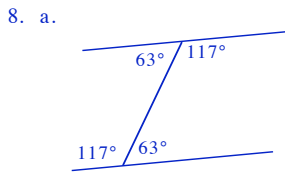
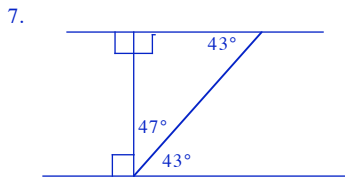

9. 120°

Answers to Chapter 13

Ch 13 - Ex 1

- 4,8,12,16,20,24
- 7,14,21,28,35,42
- 8,16,24,32,40,48,56,64,72,80
- a. T b. F c. T d. T
e. T f. F g. T h. T
- 2 - {12,14,16,18,20,24,28,30,32,36,38,40,42,44,48,50,52,54}
3 - {12,18,24,30,33,36,42,45,48,54}
4 - {12,16,20,24,28,32,36,40,44,48,52}
5 - {20,30,35,40,45,50}
6 - {12,18,24,30,36,42,48,54}
7 - {14,28,35,42,49}
8 - {16,24,32,40,48}
- a. {21,24,27,30,33,36,39}
b. {15,20,25,30,35,40,45,50}
c. {16,20,24,28,32}
d. {14,21,28,35,42,49}
- a. 4,8,12,16,20,24,28,32,36
b. 6,12,18,24,30,36,42,48,54
c. 12,24,36
d. 12
- a. 2,4,6,.....,20
b. 3,6,.....,30
c. 6,12,18
d. 6
- 24
- a. 20 b. 18 c. 10 d. 40
e. 30 f. 15 g. 30 h. 60
i. 10
- a. 12 b. 60 c. 12 d. 24
d. 24 e. 30 f. 210
- a. 60 secs b. 120 secs

Ch 13 - Ex 2

- 1,7
- 1,2,5,10
- a. 1,3,9
b. 1,13

- c. 1,3,5,15
d. 1,2,3,6,9,18
e. 1,2,4,8,16
f. 1,2,3,4,6,8,12,24
- a. 1,2,4,8,
b. 1,2,4,5,10,20
c. 1,5,25
d. 1,2,3,5,6,10,15,30
e. 1,2,4,8,16,32
- a. T b. F c. F d. T
e. F f. T g. F h. F
- 10 - {1,2,5,10}
12 - {1,2,3,4,6,12}
18 - {1,2,3,6,9,18}
25 - {1,5}
32 - {1,2,4,8,16}
36 - {1,2,3,4,6,9,12,18}
- a. 1,2,3,4,6,12
b. 1,2,4,8,16
c. 1,2,4
d. 4
- a. 1,2,4,5,10,20
b. 1,2,3,5,6,10,15,30
c. 1,2,5,10
d. 10
- a. 2 b. 5 c. 6 d. 4
e. 5 f. 6 g. 20 h. 1
i. 18
- a. 2 b. 5 c. 4
d. 8 e. 9 f. 16
- a. (i) 2 (ii) 3 (ii) 6
b. (i) 40 (ii) 30 (ii) 36

Ch 13 - Ex 3

- a. Yes (3,5) b. No
- a. No b. Yes
- It does not have 2 factors
- a. 1,2,3,.....,10
b. 2,3,5,7
- a. 11,12,13,.....,20
b. 11,13,17,19
- a. P b. P c. NP d. NP
e. P f. NP g. NP h. P
i. NP j. NP
- h. 2,3,5,7,11,13,17,19,23,29,31,37,41,43,47,53,59,61,67,71,73,79,83,89,97
- 2 x 5 x 3 x 2
- a. 2 x 2 x 3
b. 2 x 3 x 3
c. 2 x 2 x 5
d. 2 x 2 x 7
e. 2 x 2 x 2 x 2 x 2
f. 2 x 2 x 2 x 5
g. 2 x 2 x 2 x 7
h. 2 x 3 x 3 x 3
i. 2 x 2 x 2 x 3 x 3
j. 2 x 2 x 2 x 3 x 5

Answers to Chapter 14

Ch 14 - Ex 1

- see triangle
- see triangle
- see triangle
- (a) - (e) see triangles

Ch 14 - Ex 2

- see triangle
- see triangle
- see triangle
- (a) - (d) see triangles

Ch 14 - Ex 3

- see triangle
- see triangle
- see triangle
- (a) - (d) see triangles
- Since $4 \cdot 5 + 5 = 9 \cdot 5$ which is smaller than 10 you cannot draw it !!

Answers to Chapter 15

Ch 15 - Ex 1

- a. 5:2 b. 2:5
- a. 7:3 b. 3:7
- a. 13:17 b. 17:13
- a. 11:5 b. 5:11
- a. 2:9 b. 9:2
- a. 3:4 b. 4:7
c. 9:3 d. 4:9

- e. 3:7
g. 9:1
7. a. 85:43
c. 85:256
8. a. 207:313
9. a. 23:37
c. 14:23
10. a. 19:61
- f. 7:4
b. 43:85
b. 313:520
b. 23:14
b. 19:42

Ch 15 - Ex 2

1. 3:2
2. 5:9
3. a. 4:5 b. 4:5 c. 2:5 d. 3:7
e. 1:1 f. 4:1 g. 5:3 h. 3:2
i. 2:1 j. 5:7 k. 4:7 l. 6:7
m. 9:4 n. 4:3 o. 9:1 p. 1:6
q. 1:100 r. 100:1 s. 1:2 t. 9:4
u. 1:1000 v. 1:2000000
4. a. 4:8 = 1:2
b. 3:15 = 1:5
c. 4:16 = 1:4
d. 12:6 = 2:1
5. a. 4:100 b. 1:25
6. a. 15:5 b. 3:1
7. a. 9:1 b. 1:9
8. a. 210:120 b. 7:4
9. a. 60000:24000 b. 5:2
10. a. 550:330 b. 5:3
11. a. 48:176 b. 3:11
12. a. 48:36 b. 4:3
13. a. 3:1 b. 35:15 = 7:3
c. 40
14. a. 1:100 b. 1:1000 c. 1:2 d. 1:6
e. 1:7 f. 1:5 g. 1:4 h. 1:4
15. a. 4:20:6:30 b. 2:3

Ch 15 - Ex 3

1. 18
2. 100
3. a. (i) 8 (ii) 40 (iii) 400 (iv) 1800
b. (i) 16 (ii) 40 (iii) 96 (iv) 400
4. a. 2 b. 6 c. 18 d. 50
5. 16
6. 170
7. a. 14 b. 10
8. a. 52 b. (i) 7 (ii) 35
9. a. £72 b. £30
10. 24
11. a. 65 b. 104
12. 23 + 460 = 483
13. a. vindaloo b. medium
c. mild d. light
e. very strong
14. a. 5 metres b. 30 cm
15. Simon = £6, Garfunkle = £3
16. Torvell = £75, Dean = £50

Answers to Chapter 16

Ch 16 - Ex 1

1. a. 3cm³ b. 5cm³ c. 7cm³
d. 9cm³ e. 18cm³
2. a. 8 b. 2 c. 16cm³
3. a. 15 b. 2 c. 30cm³
4. a. 8cm³ b. 24cm³ c. 45cm³
d. 36cm³ e. 63cm³
5. a. 36cm³ b. 32cm³ c. 54cm³
d. 36cm³ e. 60cm³ f. 44cm³
6. a. 5cm³ b. 7cm³ c. 9cm³
d. 13cm³ e. 13cm³
7. a. see sketches
b. (i) 16cm³ (ii) 19cm³ (iii) 10cm³
(iv) 24cm³ (v) 12cm³

Ch 16 - Ex 2

1. 56cm³
2. 250cm³
3. 120cm³
4. a. 45cm³ b. 42cm³ c. 140cm³ d. 72cm³
e. 240cm³ f. 1200cm³
5. a. 1020cm³ b. 1000cm³
c. 1080cm³ d. 3780cm³
e. 1125cm³ f. 8cm³
6. a. 12m³ b. 32cm³ c. 154cm³
d. 480mm³ e. 80cm³ f. 60m³
7. a. 128cm³ b. 660cm³
c. 740cm³ d. 6450cm³

- e. 10750mm³
8. $h = 3$ cm
9. a. 4cm b. 2cm c. 10cm

Ch 16 - Ex 3

1. a. 160cm³ b. 160ml
2. a. 180cm³ b. 180ml
3. a. 2400ml b. 3000ml
c. 2940ml d. 2100ml
e. 5400ml f. 8400ml
4. a. 1000cm³ b. 1000ml
c. 1 litre
5. a. 4l b. 7l c. 18l d. 6·5l
e. 1·3l f. 12·45l g. 0·4l h. 0·2l
i. 0·75l
6. a. 24l b. 1·2l c. 12l
7. a. 336000cm³ b. 336l c. 84
8. a. 160000cm³ b. 16000ml
c. 160 litres
9. 20cm
10. a. 40m³ b. 200m³ c. 190m³
11. a. 8000cm³ b. 8 litres
c. 160000cm³ d. 160 litres
e. 20 times
12. a. 90 b. 45 c. 18 d. 27
13. a. 480000cm³ b. 480 litres
c. 96 minutes

Answers to Chapter 17

Ch 17 - Ex 1

1. a. 7cm by 3·5cm
b. 28m by 14m
2. a. 2·5cm b. 3·75m
c. 5·8 x 1·5 = 8·7m
3. a. 3 x 40 = 120cm
b. 4 x 40 = 160cm
4. a. 6cm by 4·5cm
b. 150m by 112·5m
c. 525m
5. a. 7cm b. 2·10m c. 1·05m
6. a. 15 x 80 = 12m
b. 3 x 80 = 2·4m
7. a. 5·2cm b. 26m
8. a. 7cm by 3·5cm
b. 28m by 14m
c. 6·5 x 4 = 26m
9. a. 6·4cm b. 64km
c. (i) 66km (ii) 70km
10. a. 6·3cm b. 126 miles
c. (i) 4·8 x 20 = 96 miles
(ii) 7·5 x 20 = 150 miles
(iii) 4·9 x 20 = 98 miles
d. 416 miles (410 - 420)
11. a. 7cm b. 350m
c. 27·5 x 50 = 1·375km

Ch 17 - Ex 2

1. see drawing (5cm by 4cm)
2. see rectangle (7cm by 12cm)
3. see rectangle (5·5cm by 4cm)
4. see rectangle (5cm by 11cm)

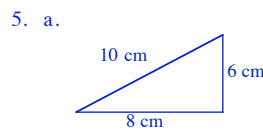

- b. 1000 metres

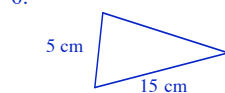

- 7.

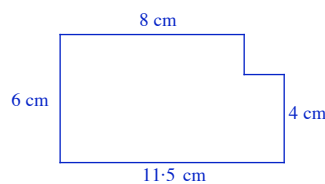

- 8.

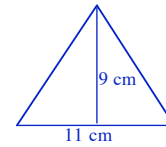

9. a.

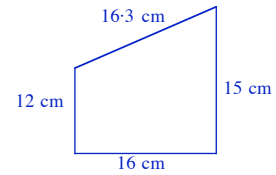

- b. 16·3cm = 815cm

Ch 17 - Ex 3

1. a. see drawing

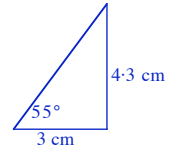

- b. 4·3cm x 2 = 8·6cm
2. a. see triangle
b. 4·3cm c. 12·9m
3. a. see triangle
b. 11·2cm → 112m
4. a. 10·6m b. 250m
c. 92m d. 1300m
5. a. see drawing
b. 12·4cm → 496cm
6. a. see drawing
b. 15cm → 45m
7. a. see triangle
b. 3cm → 7·5km
8. a. see drawing
b. 115km

Ch 17 - Ex 4

1. a. check compass
2. a. 90° b. 180° c. 270° d. 90°
e. 45° f. 135° g. 180° h. 135°
i. 135° j. 225°
3. a. S b. SW c. SE
4. a. (i) Evil Isle (ii) Far-Out Point
(iii) Reservoir (iv) Brockville
b. (i) N (ii) NE (iii) W (iv) SW

Ch 17 - Ex 5

1. 120°
2. a. 070° b. 160° c. 105°
3. a. 180° b. 090° c. 135° d. 045°
4. a. 270° b. 225° c. 315°
5. 305°
6. a. 240° b. 275° c. 328°
7. Ardear - 045° Blakwell - 095°
Crumnock - 140° Devlon - 200°
Early - 252° Froglin - 295°
Googly - 332°
8. see figures
9. a. see figures
b. 12·1cm c. 121km
10. a. see figures
b. 11·9cm c. 11·9km
11. a. see figures
b. 12·4cm c. 62km

Answers to Chapter 18

Ch 18 - Ex 1

1. a. Yes b. Yes c. Yes d. 4
e. (i) Yes (ii) Yes f. 8 g. Yes
h. Yes i. Yes j. Yes
2. (i) it has all 4 sides the same
(ii) it has all 4 angles = 90°
(iii) its opposite sides are parallel
(iv) it has 4 lines of symmetry
(v) it has 1/2 and 1/4 turn symmetry
(vi) it fills its outline in 8 ways
(vii) its diagonals are the same length

- (viii) each diagonal bisects the other
- (ix) the diagonals meet at 90°
- (x) the diagonals bisect the end angles

3.

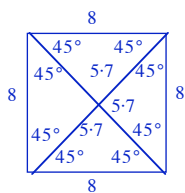

- 4. a. see drawing of square b. 8.5cm
- 5. a. see drawing of square
- b. 7.1cm
- 6. a. see drawing
- b. 8.5cm
- 7. a. square of side 7 cm b. 9.9cm
- 8. a. 25cm^2 b. 144cm^2
- c. $12 \cdot 25\text{cm}^2$ d. Yes
- 9. a. 9cm b. 36cm
- 10. 135°

Ch 18 - Ex 2

- 1. a. No b. Yes c. Yes d. Yes
- e. 2 f. (i) Yes (ii) No g. 4
- h. Yes i. Yes j. No k. No
- 2. (i) it does not have all 4 sides the same length
- (ii) it only has 2 lines of symmetry - not 4
- (iii) it only has $1/2$ turn symmetry not $1/4$
- (iv) it only fits its outline 4 times - not 8
- (v) it diagonals do not meet at 90°
- (vi) it diagonals do not bisect the end angles
- 3. a. see sketch

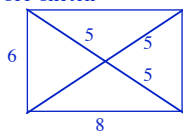

- 4. a. see drawing b. 5cm
- 5. see drawing
- 6. see drawing
- 7. a. possibly 7cm by 1cm
- b. possibly 6cm by 2cm
- c. possibly 5cm by 3cm
- d. a square
- 8. 32cm^2
- 9. a. 84cm^2 b. 180cm^2
- c. 650cm^2
- 10. a. $IL = 5\text{cm}$, $LK = 8\text{cm}$
- b. $\angle LIJ = 90^\circ$, $\angle LKJ = 90^\circ$
- c. $\angle ILJ = \angle LJK = 58^\circ$
- $\angle IJL = 32^\circ$

11. a.

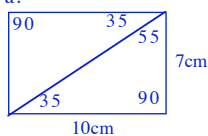

b.

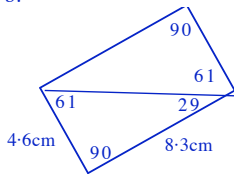

12. a. (i) 30° (ii) 60°

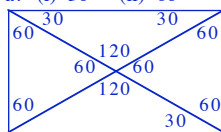

13.

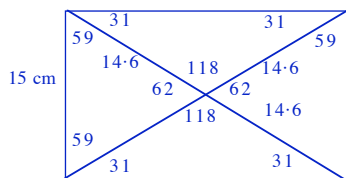

14. a.

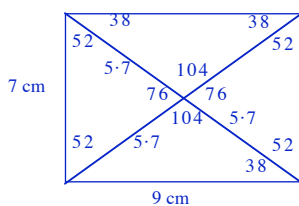

b.

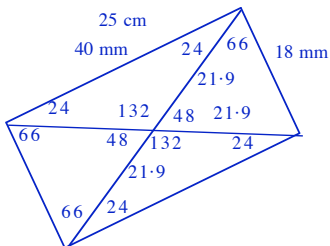

15. 141°

16. 65°

Ch 18 - Ex 3

- 1. a. 290° b. 70°
- 2. a. $x = 115^\circ$
- b. 97° c. 65° d. 107°
- 3. 55°
- 4. 100°

Ch 18 - Ex 4

- 1. a. Yes b. Yes c. No d. Yes
- e. 2 f. (i) Yes (ii) No g. 4
- h. No i. Yes j. Yes k. Yes
- 2. (i) it does not have all angles the same
- (ii) it only has 2 lines of symmetry - not 4
- (iii) it only has $1/2$ turn symmetry not $1/4$
- (iv) it only fits its outline 4 times - not 8
- (v) it diagonals are not the same length
- 3. a. 10cm b. $PM = 8\text{cm}$ $SM = 6\text{cm}$
- 4. see drawing
- 5. a. see drawing b. 5.8cm
- 6. see drawing
- 7. a. see drawing b. square
- 8. a. 50° b. 130° c. 130°
- 9. a. 110, 70, 70
- b. 65, 115, 115
- c. 140, 40, 40
- 10. a. isosceles b. 25° c. 130°
- 11. a.

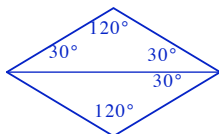

b.

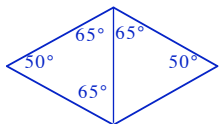

c.

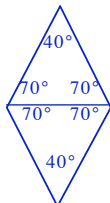

12.

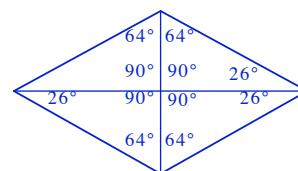

13. a.

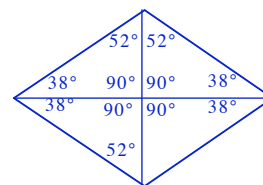

b.

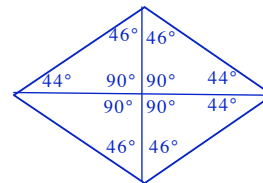

14. square

15.

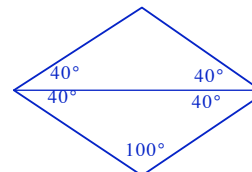

16. a. 60° b. 120°

17. 115°

18.

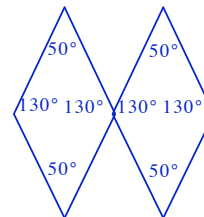

19. 115° , 115° , 65° , 65°

Ch 18 - Ex 5

- 1. a. No b. No c. Yes (adjacent)
- d. No e. No f. No g. Yes
- h. 1 i. No j. 2 k. No
- l. No m. Yes n. Yes o. No
- p. Yes
- 2. various properties
- 3. $PQ = 5\text{cm}$ $PS = 8.9\text{cm}$ $PT = 4\text{cm}$
- 4. a. (i) 110° (ii) 50°
- b. (i) 20° (ii) 20°
- 5. a.

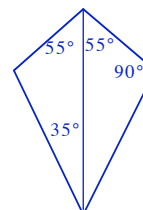

b.

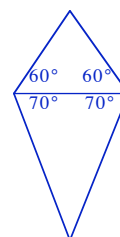

c.

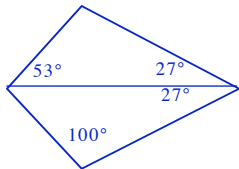

6. a. (i) 25° (ii) 70° (iii) 90°
 b. (i) 65° (ii) 20° (iii) 40°
 7. a.

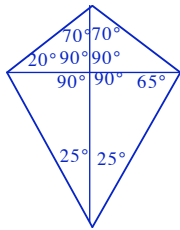

b.

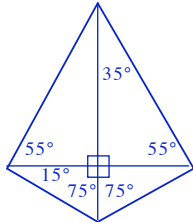

c.

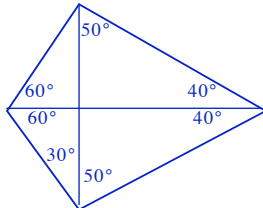

8. Rhombus

9. a. 45° b. 95°
 10. a. 95° and 120°
 b. 90° and 90°
 c. 88° and 126°
 11. 105°

Ch 18 - Ex 6

1. a. No b. Yes c. Yes d. No
 e. Yes f. (i) Yes (ii) No g. none
 h. 2(not 4) i. NO j. Yes
 k. No l. No
 2. various
 3.

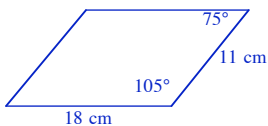

4. a. 100° b. 360° c. 80°
 5. a. 180° b. 180° c. add to 180°
 6. 132°
 7. a. 64° b. 80° c. 36° d. 80°
 8. a.

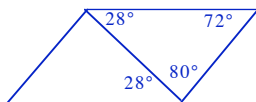

b.

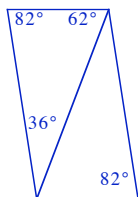

c.

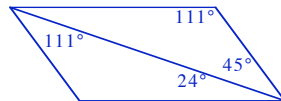

9. a. b.

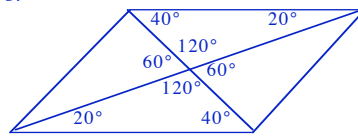

c. No

10. 40°, 80°, 40°

11. a.

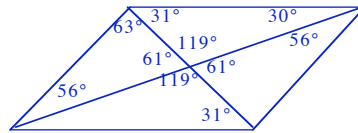

b.

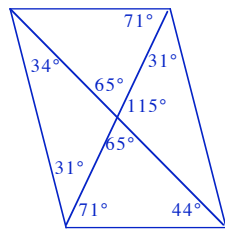

12. 105°

14. 113°

13. 124°

15. 30°

Ch 18 - Ex 7

1. 105°
 2. 100° and 110°
 3. a. 109° and 55°
 b. 90° and 73°
 c. 111° and 59°
 4. 70°, 110°, 110°
 5. a. 116°, 64°, 64°
 b. 37°, 143°, 143°
 c. 116°, 116°, 64°, 64°
 6. 70°, 70°, 110°, 110°
 7. 155°

Answers to Chapter 19

Ch 19 - Ex 1

1. see drawing with circle labelled
 2. a. diameter b. radius
 c. radius d. diameter
 3. a. CR b. PQ c. PC and QC
 4. a. 30cm b. 25cm
 5. check drawing 6. check drawing

Ch 19 - Practical Exercise

1. see table
 2. a. 12cm b. 75cm c. 28.5cm
 d. 10.5cm e. 2.1cm

Ch 19 - Ex 2

1. 15.7cm
 2. 50.24cm
 3. a. 9.42cm b. 34.54cm
 c. 21.98cm d. 109.9cm
 e. 15.07cm f. 75.36cm
 g. 1.57cm h. 26.06cm
 4. 100.48cm 5. 194.68cm
 6. 157cm 7. 37.68cm
 8. 14cm
 9. a. 36cm, 113.04cm
 b. 10cm, 31.4cm
 c. 3cm, 9.42cm
 10. a. 48cm b. 150.72cm
 11. a. 3cm b. 9.47cm
 12. a. 282.6m b. 7.065km
 13. 30.14cm 14. 56.52cm
 15. 15.70cm

Answers to Chapter 20

Ch 20 - Ex 1

1.

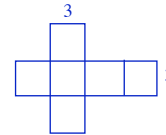

2. Similar net with 5 cm
 3. a. Y b. N c. Y
 d. Y e. N f. Y
 4. Any 2 nets of cubes
 5. a. 1 above and 1 below
 b. not both above or below

Ch 20 - Ex 2

1. a. 9cm² b. 54cm²
 2. a. 24cm² b. 486cm² c. 150cm²
 3. a. 96cm² b. 600cm² c. 253.5cm²
 d. 61.44cm²
 4. a. 294cm²
 5. a. 384cm² b. 6cm² c. 13.5cm²
 d. 110.94cm²

Ch 20 - Ex 3

1. see net 2. see net
 3. see nets
 4. a.

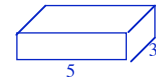

b. c. see sketches

5. 62cm²
 6. 136cm²
 7. 276cm²
 8. a. 712cm² b. 948cm²
 c. 576cm²
 9. a. 7cm by 5cm (both)
 b. 166cm²
 10. a. 3 pieces, 14cm by 5cm
 1 piece, 5cm by 5cm
 b. 330cm²
 11. a.

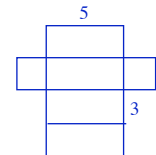

b. 78cm²

Ch 20 - Ex 4

1. see net
 2.

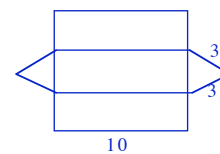

3. a. 7cm by 5cm (2 pieces)
 + 1 piece (7cm by 3cm)
 b. see net
 4. a. see net
 b. 96cm²

TeeJay Publishers



Teejay Publishers

This textbook covers the entire content of 5-14 Level E and is meant to be completed in approximately 1 year.

It includes a Chapter Zero, which consists of an in-depth look at every strand in Level D. in preparation for a sound start to Level E.

Extension materials in photocopiable form are available to enhance the course for those Pupils coping well with the textbook exercises.

Homework Exercises, Revision work and Assessments, in photocopiable form, are also available for use in class and at home.

**P.O. Box 1375
Barrhead
Glasgow G78 1JJ**

**e-mail:
teejaypublishers@ntlworld.com**

**web-site:
www.teejaypublishers.co.uk**

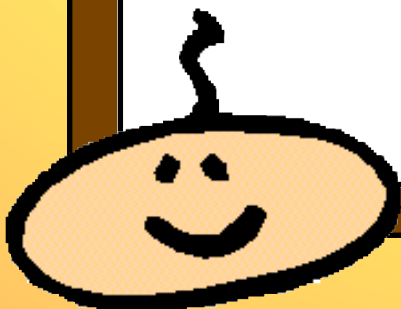

sums 'R us