

Learning First Numbers

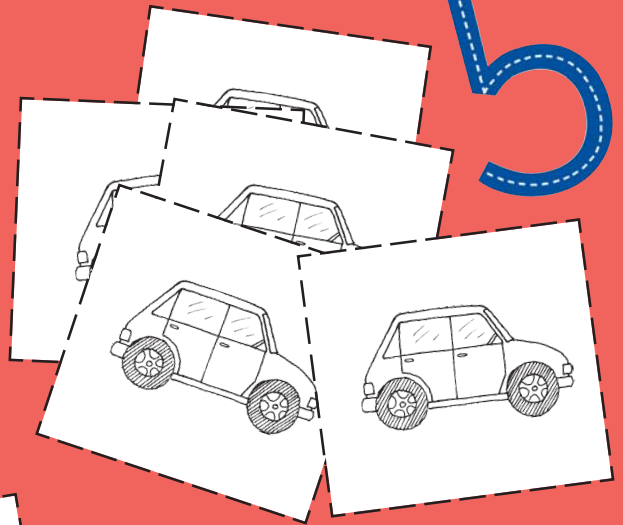

3



5



7

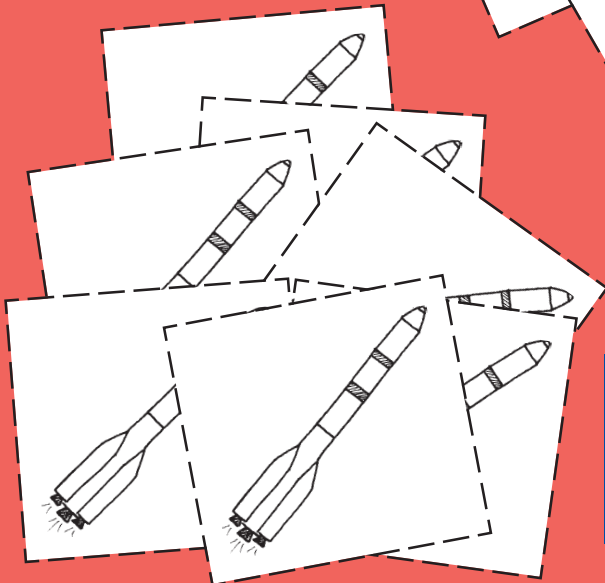

8

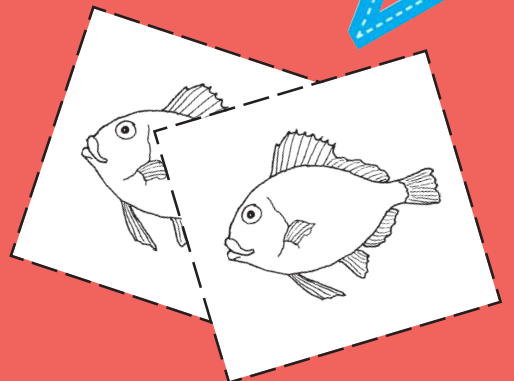

2

Contents

	page
Numbers 1 to 10 main worksheets (3 pages per number)	1-30
Alternative number formation sheets	31-35
Using picture sheets: instructions and ideas	36
Picture sheets: numbers 1 to 5 only	37-41
numbers 1 to 10	42-56
Extension/consolidation activity	57-58

I can count
1 boat.

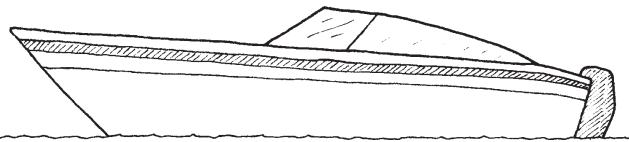

Cut and stick   or draw  1 car.

car



Write 

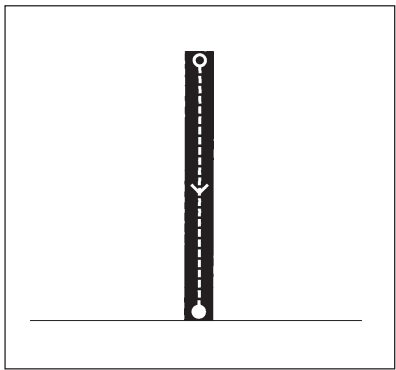

Two rows of handwriting practice lines. Each row consists of a solid top line, a dashed middle line, and a solid bottom line. The first row has a solid vertical line on the left followed by seven dashed vertical lines. The second row has a dashed vertical line on the left followed by seven solid vertical lines.

I can count
1 girl.

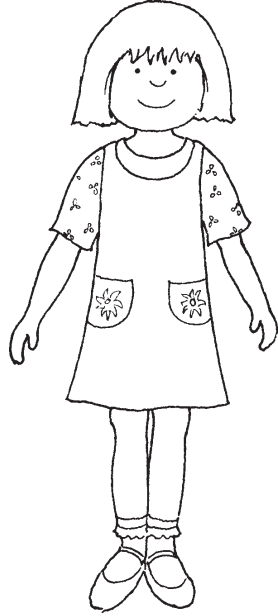

Cut and stick   or draw  1 boy.



Write 

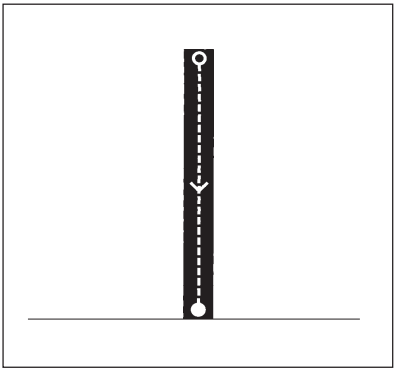

Two rows of writing practice lines. Each row consists of a solid top line, a dashed middle line, and a solid bottom line. The first row has eight vertical lines (one solid, seven dashed) for tracing. The second row has two vertical lines (one solid, one dashed) for tracing.

I can count
1 kite.

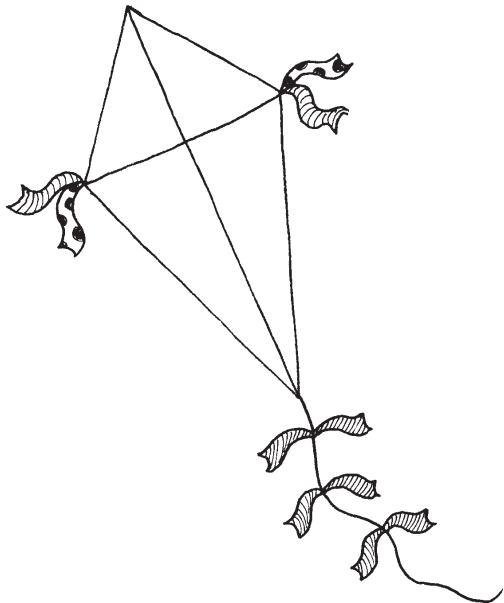

Cut and stick   or draw  1 ball.

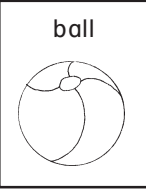

Write 

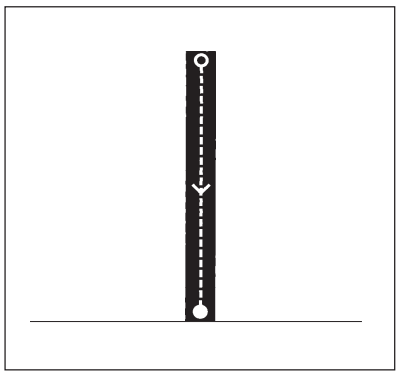

Two rows of handwriting practice lines. Each row consists of a solid top line, a dashed middle line, and a solid bottom line. The first row has a solid vertical line on the left followed by seven dashed vertical lines. The second row has a dashed vertical line on the left followed by seven dashed vertical lines.

I can count
2 crocodiles.

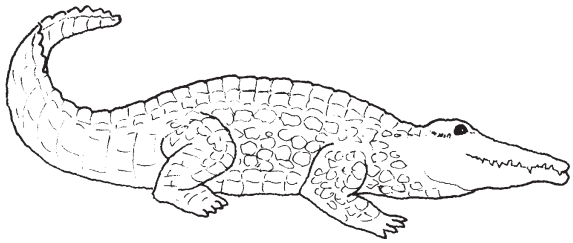
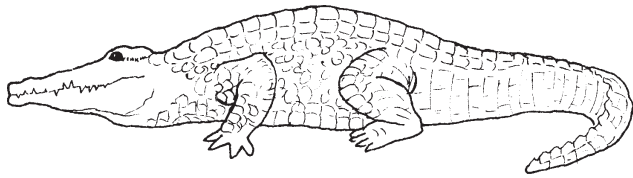

Cut and stick   or draw  2 monkeys.

monkey



Write 

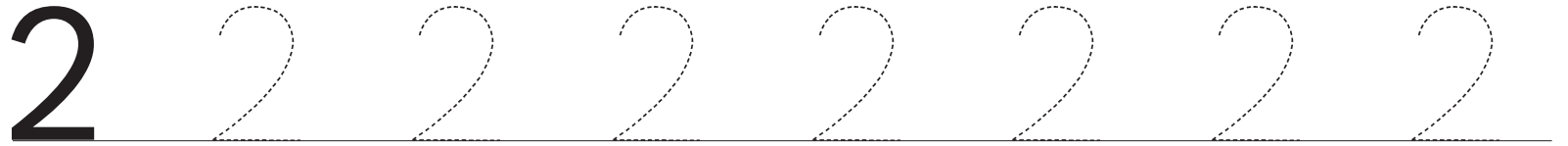
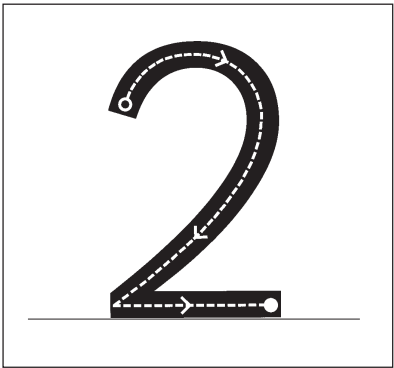

I can count 2 planes.

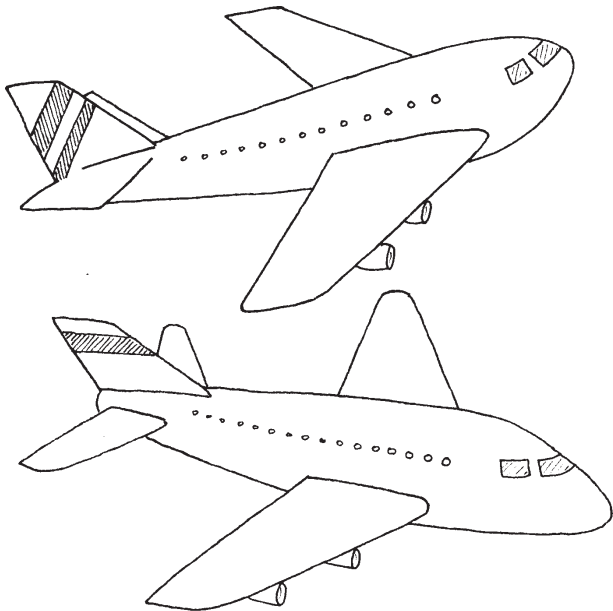

Cut and stick   or draw  2 rockets.

rocket

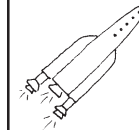

Write 

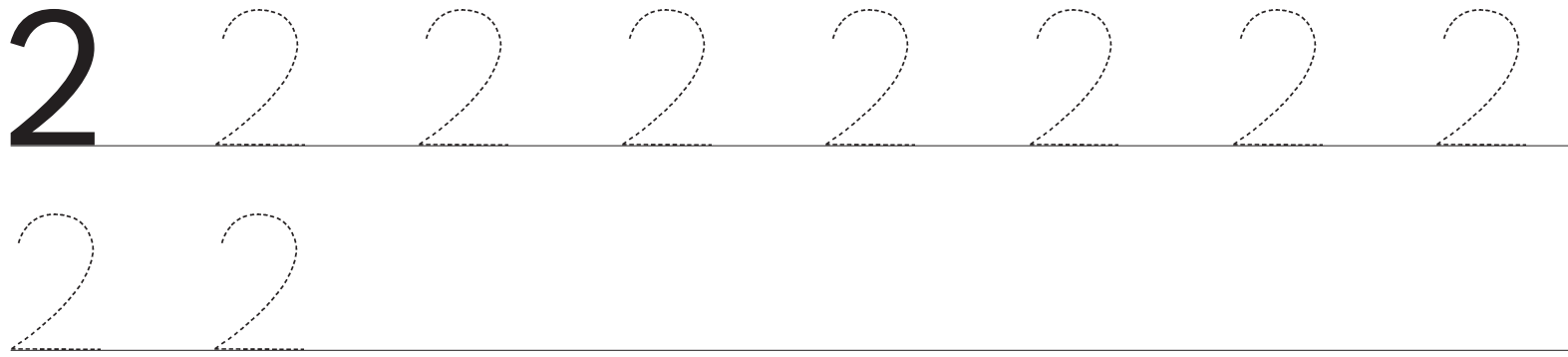
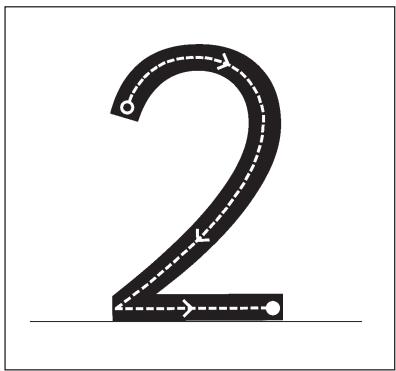

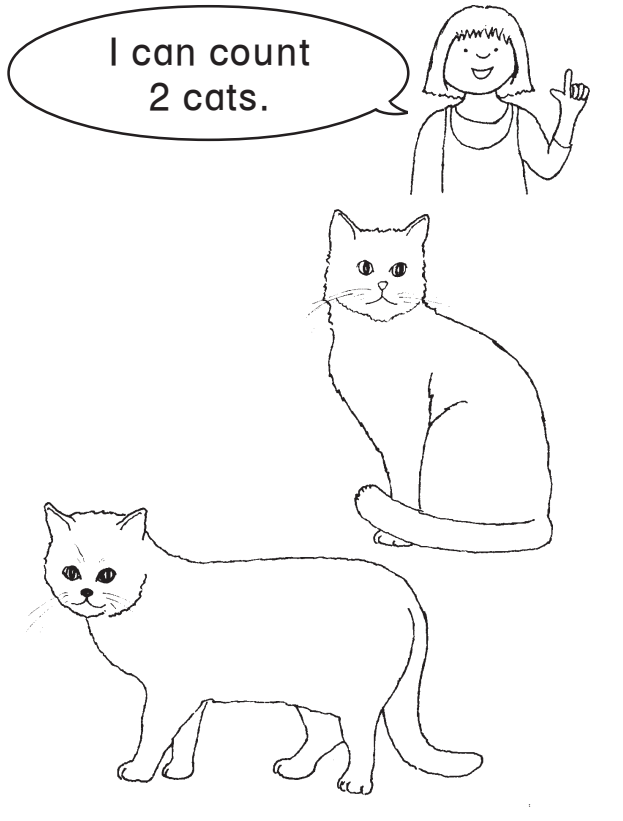

Cut and stick   or draw  2 dogs.

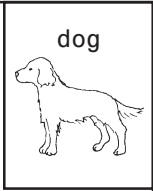

Write 

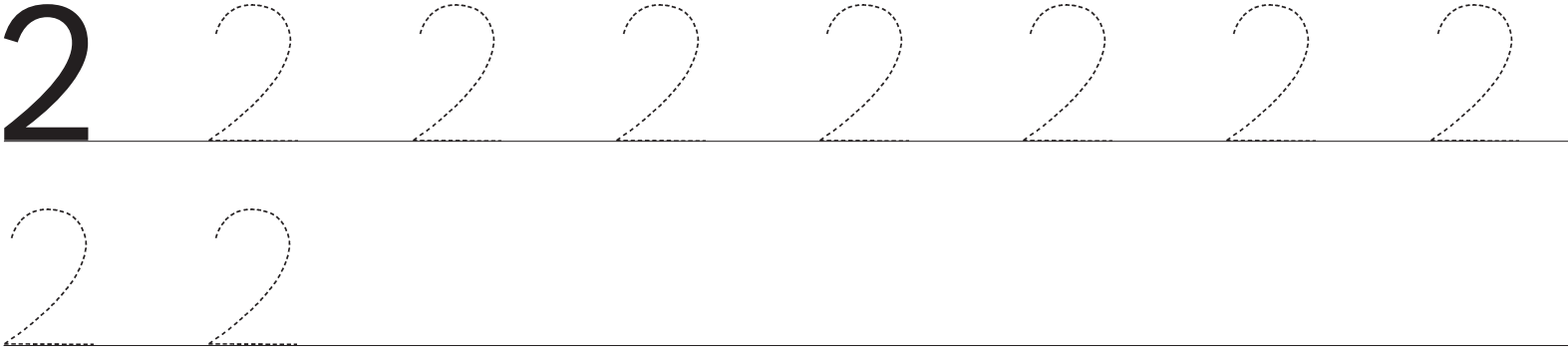
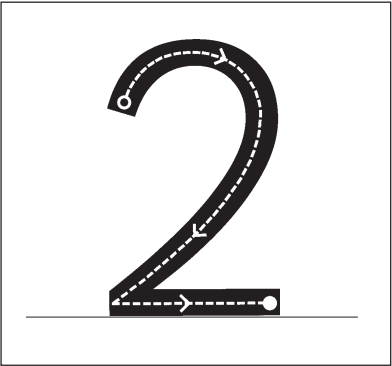

I can count 3 horses.

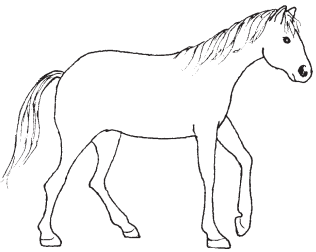
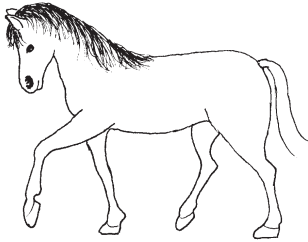
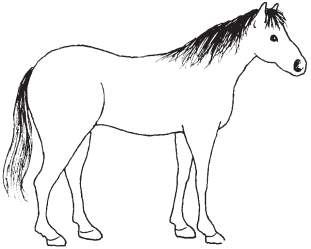

Cut and stick   or draw  3 cows.

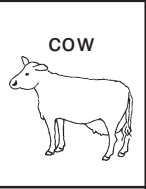

Write 

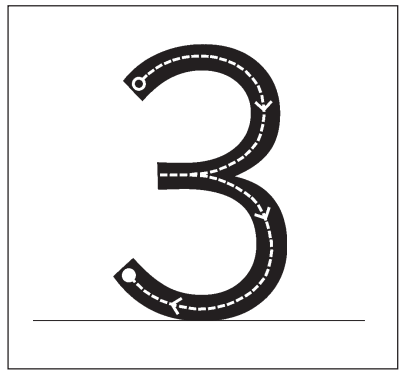

I can count
3 trees.

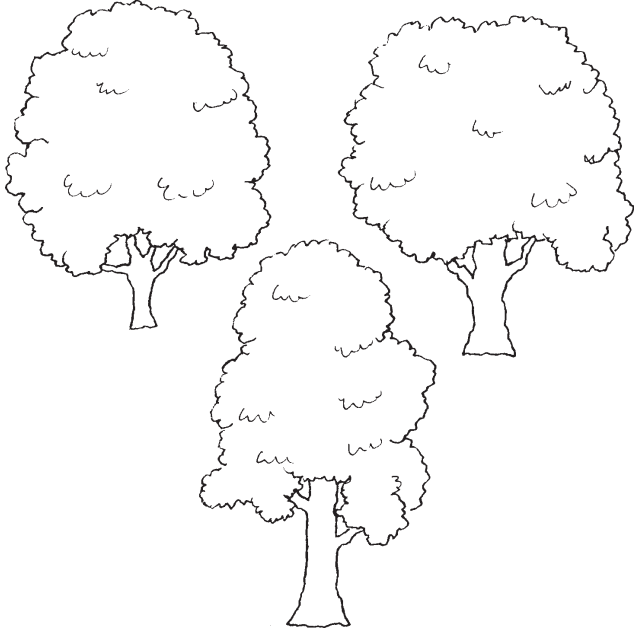

Cut and stick   or draw  3 flowers.

flower

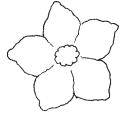

Write

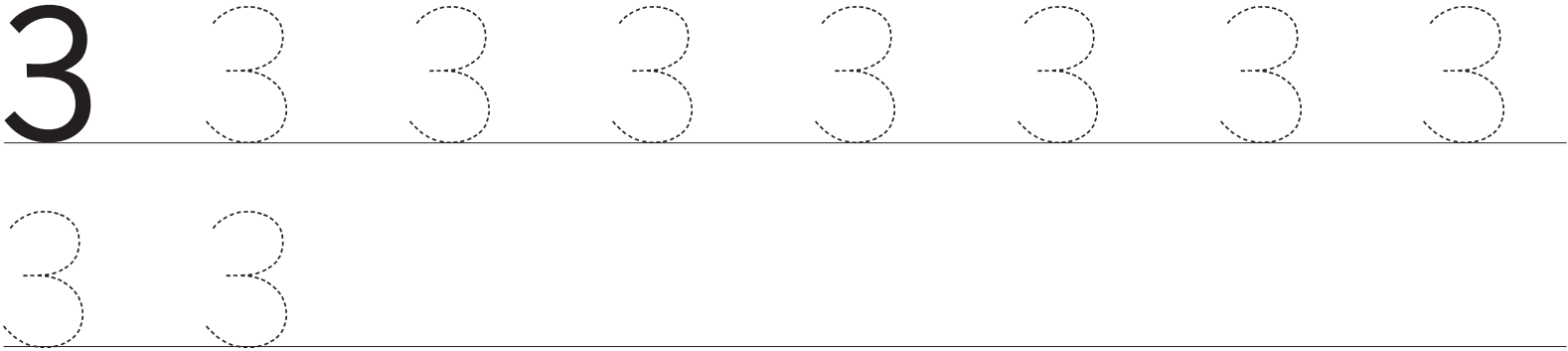
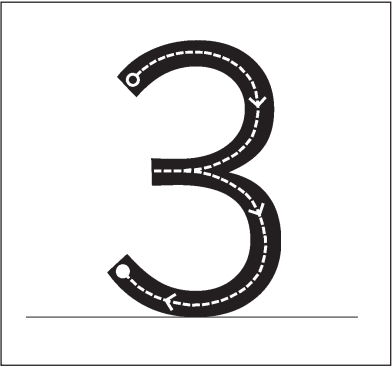

I can count 3 houses.

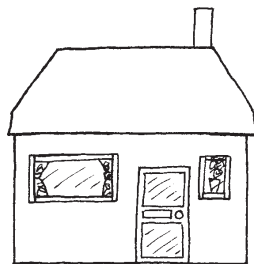
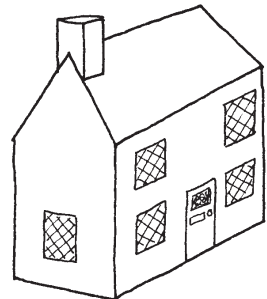
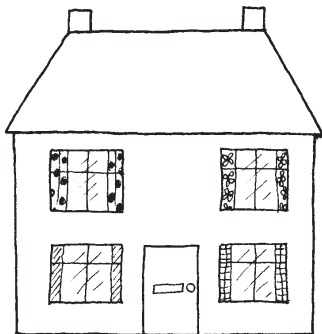
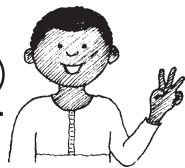

Cut and stick   or draw  3 castles.

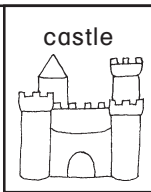

Write 

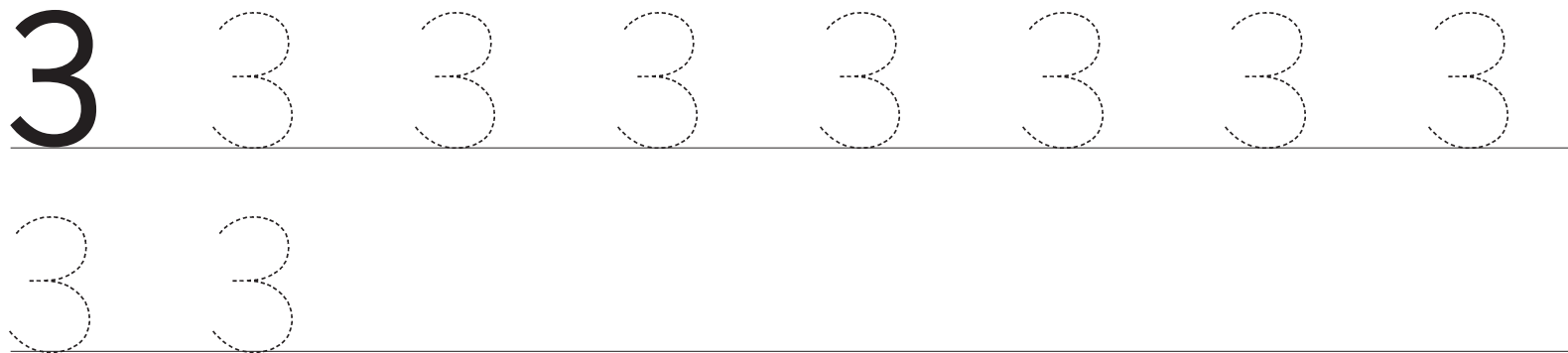
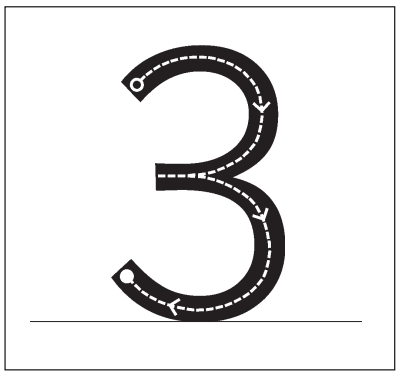

I can count 4 cars.

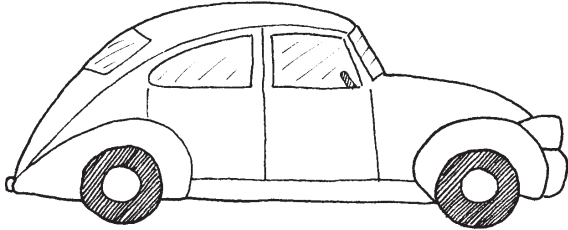
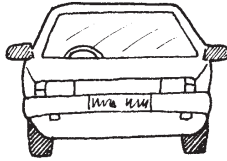
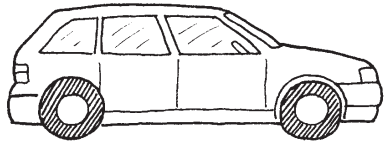
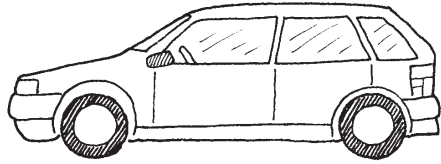

Cut and stick   or draw  4 buses.

bus



Write 

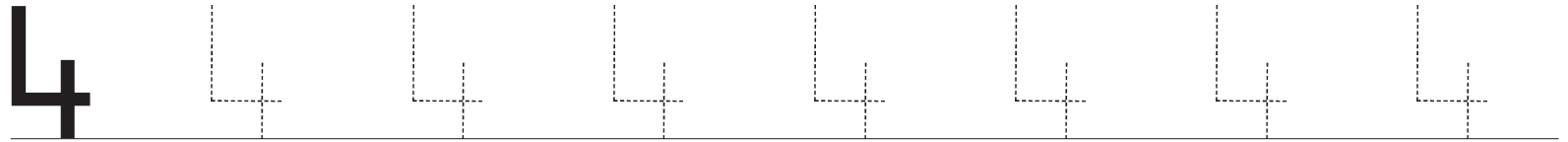
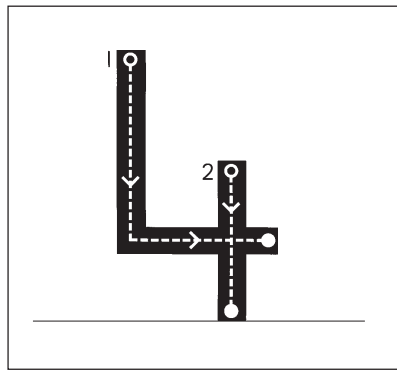



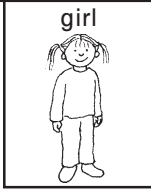

Cut and stick   or draw  4 girls.

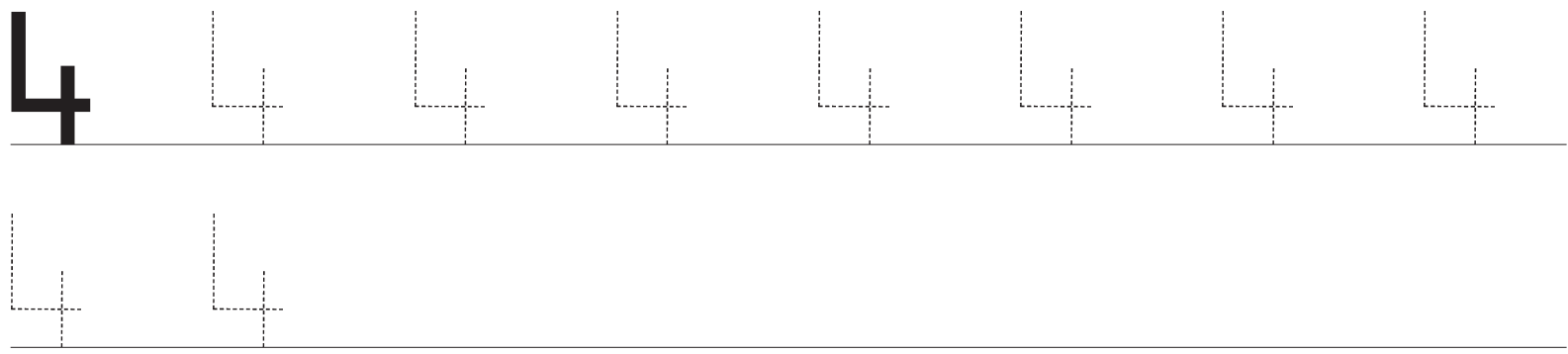
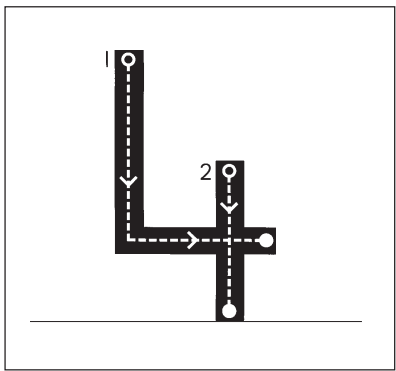

Write 

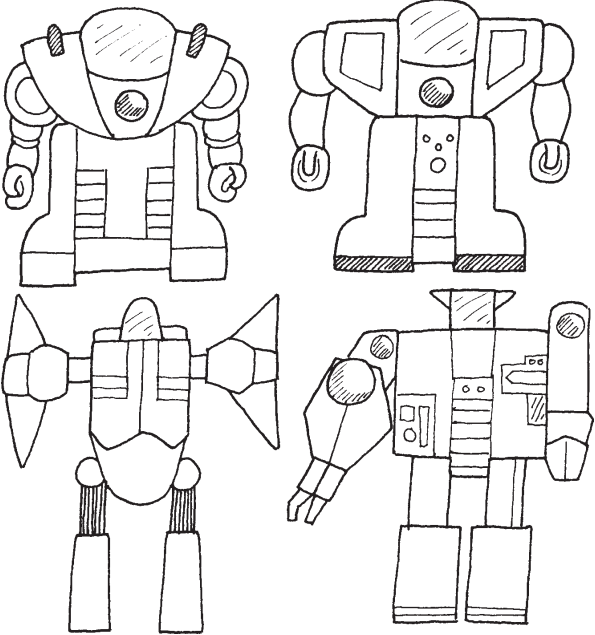

I can count 4 robots.



Cut and stick   or draw  4 clocks.

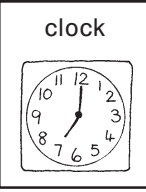

Write 

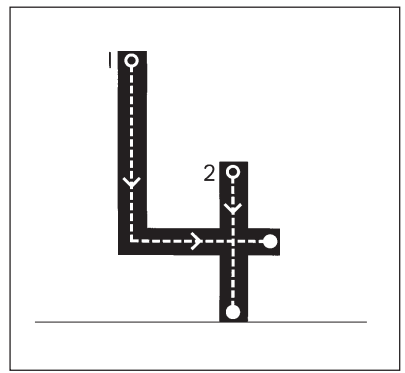

4 4 4 4 4 4 4

4 4

I can count 5 birds.



Cut and stick   or draw  5 spiders.

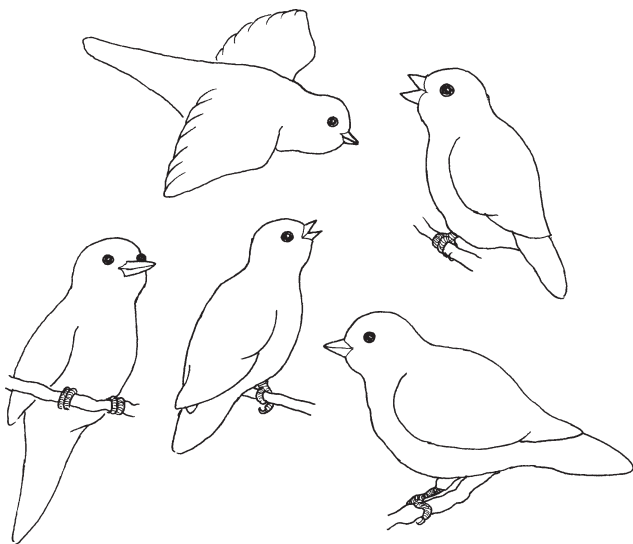
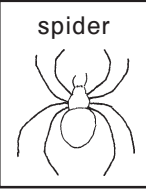

Write 

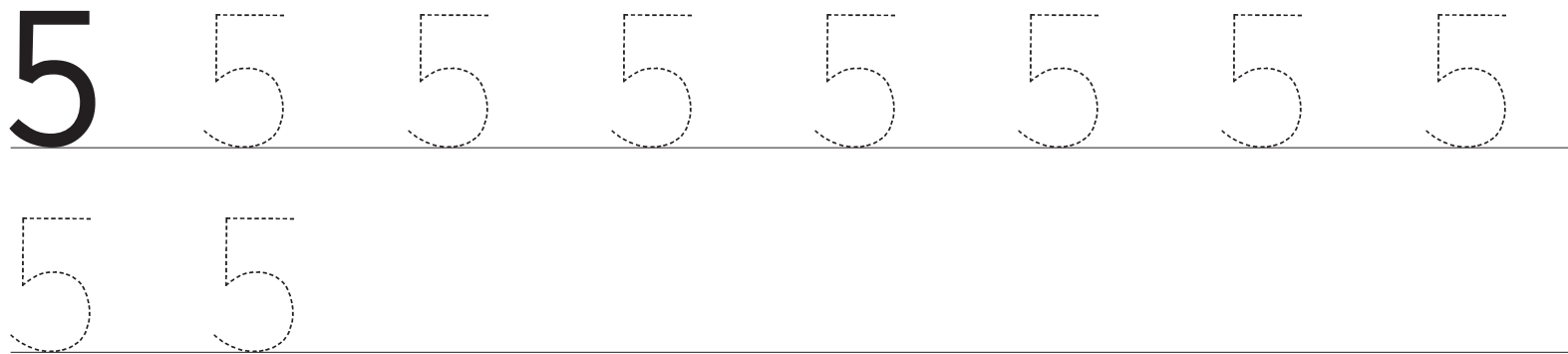
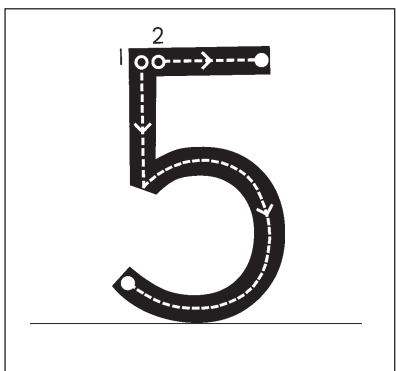

Teachers' note: you may wish to reverse the 2nd starting and finishing point, and directional arrow, for left-handed pupils.

I can count 5 buckets.

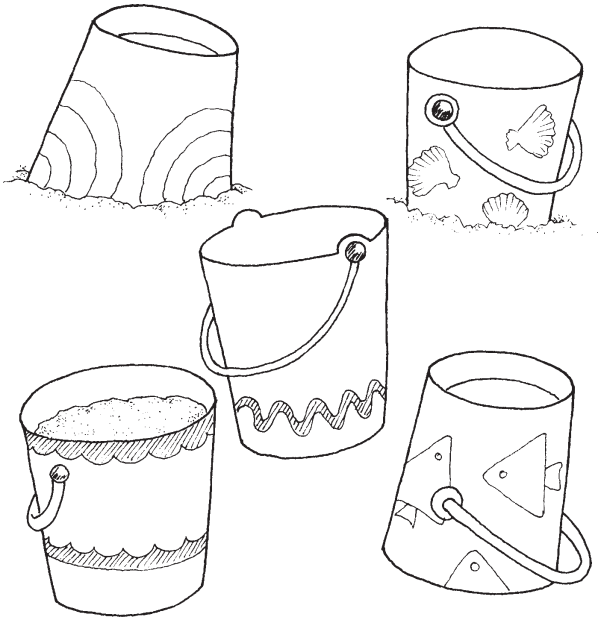

Cut and stick   or draw  5 spades.

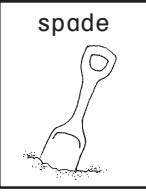

Write 

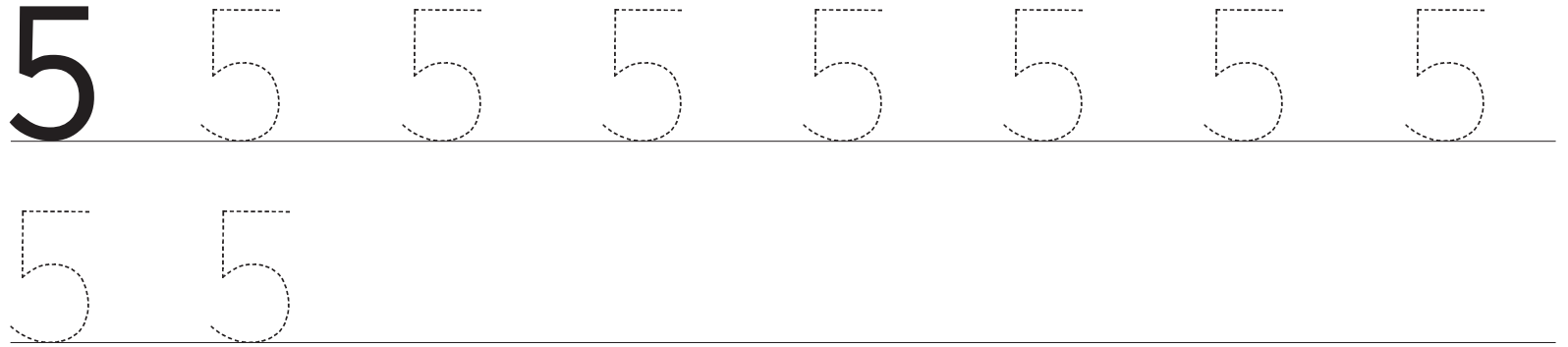
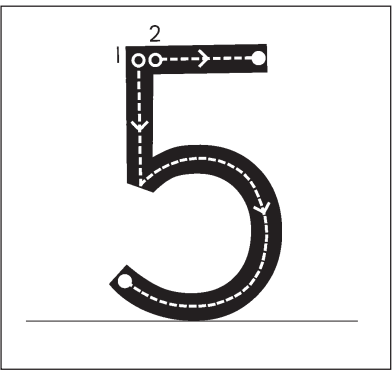

Teachers' note: you may wish to reverse the 2nd starting and finishing point, and directional arrow, for left-handed pupils.

I can count 5 teddies.



Cut and stick   or draw  5 dolls.

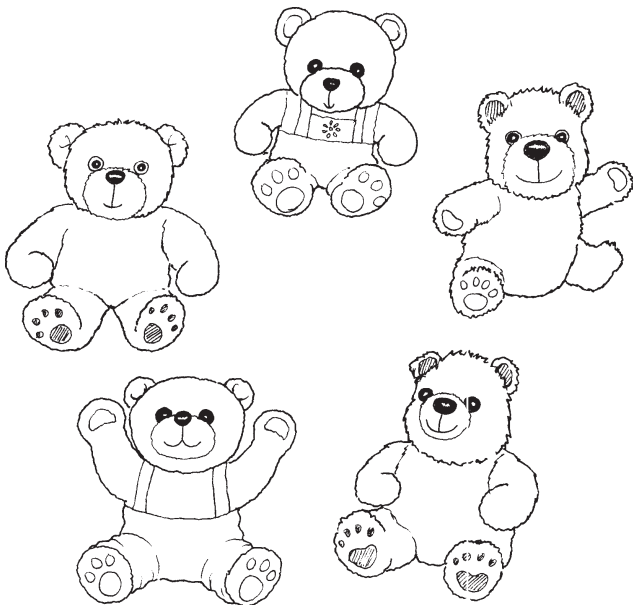

Write 

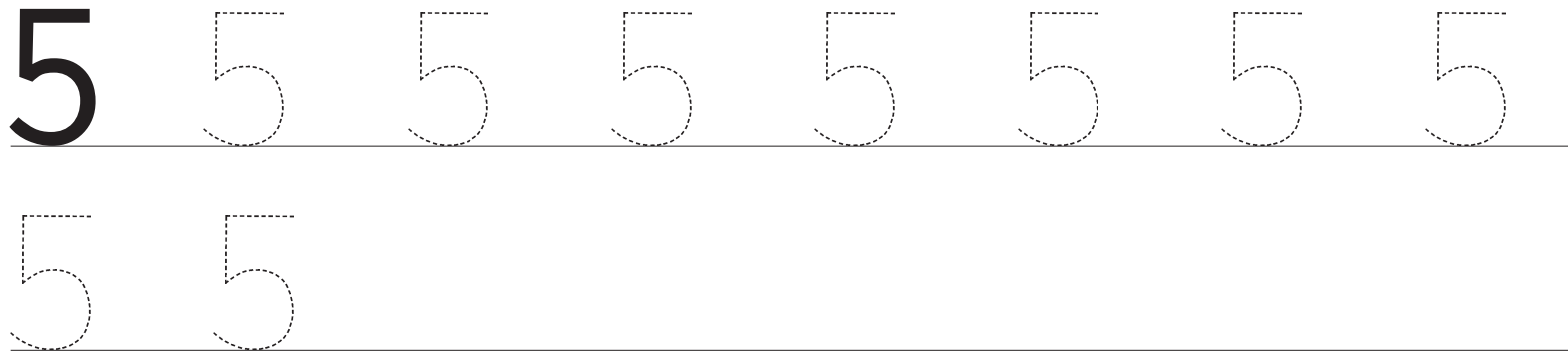
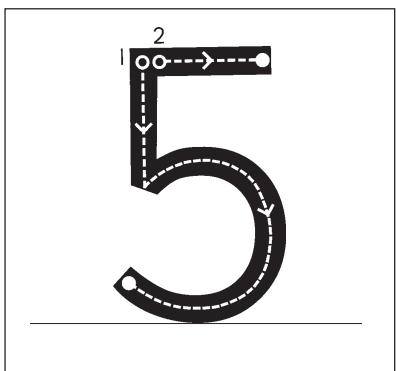

Teachers' note: you may wish to reverse the 2nd starting and finishing point, and directional arrow, for left-handed pupils.

I can count 6 pencils.



Cut and stick   or draw  6 books.



book

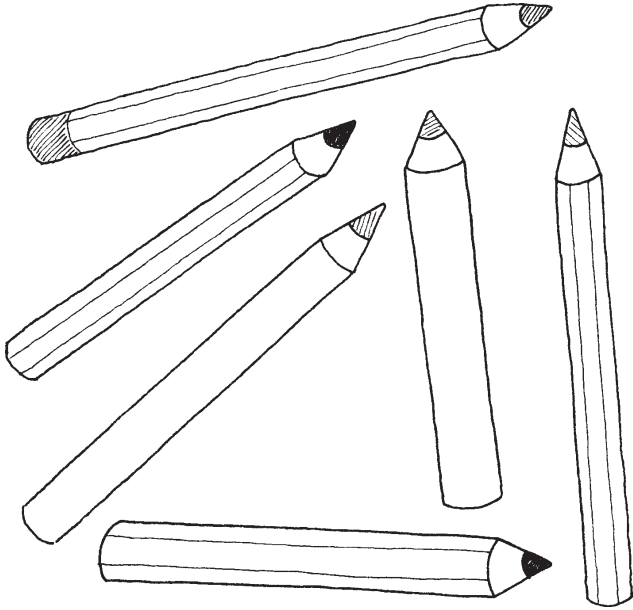

Write 

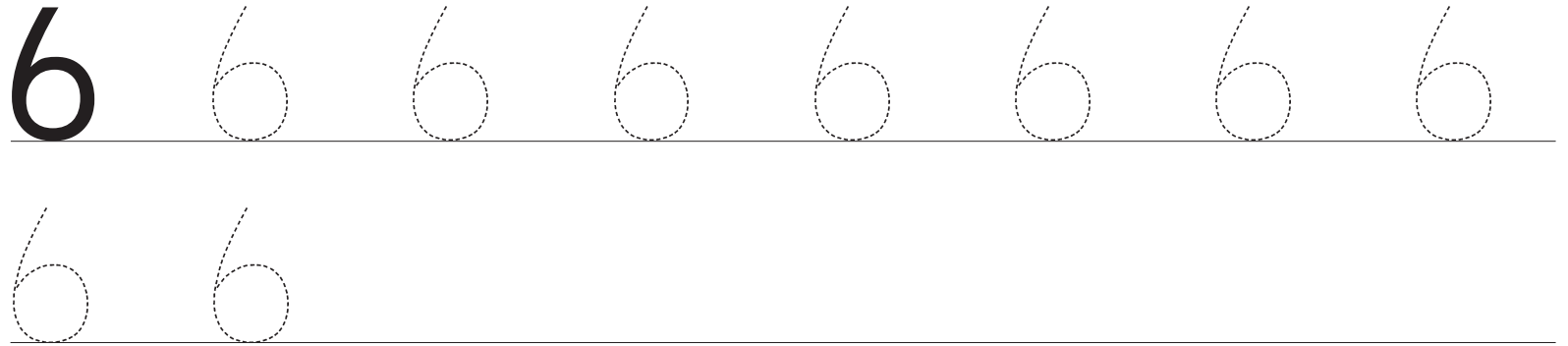
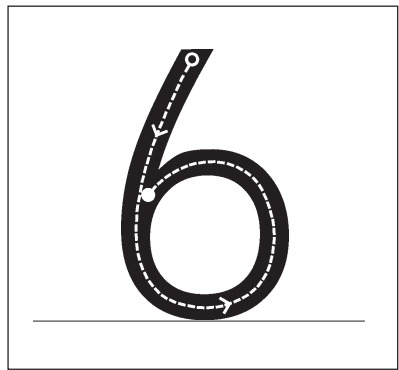

I can count 6 balloons.

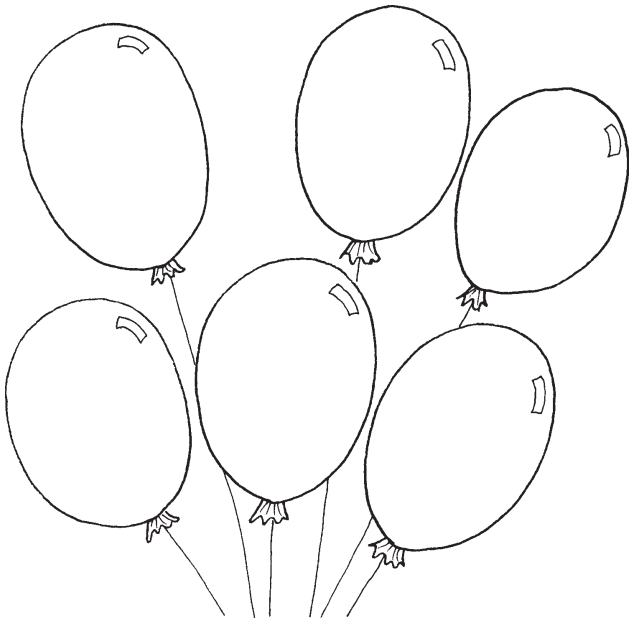

Cut and stick   or draw  6 kites.

kite



Write 

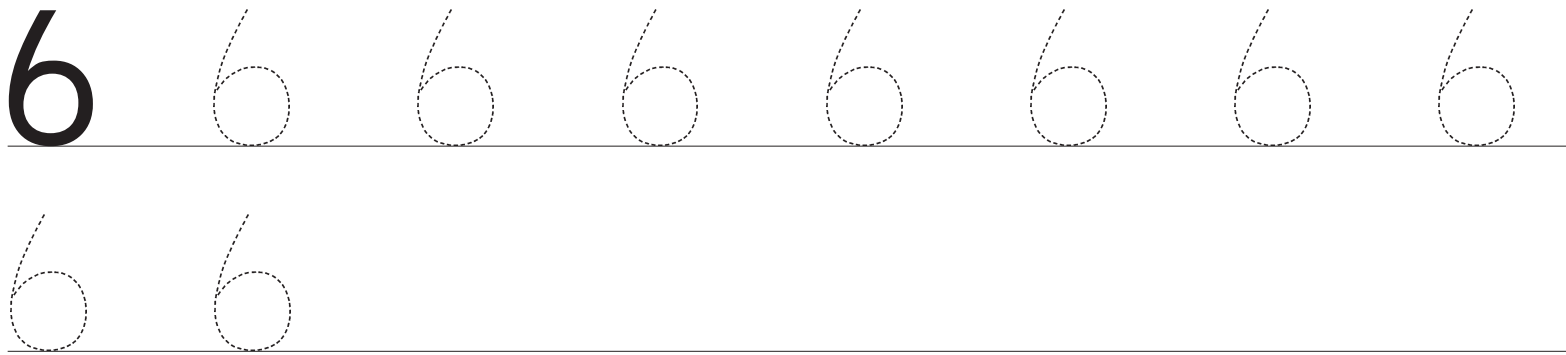
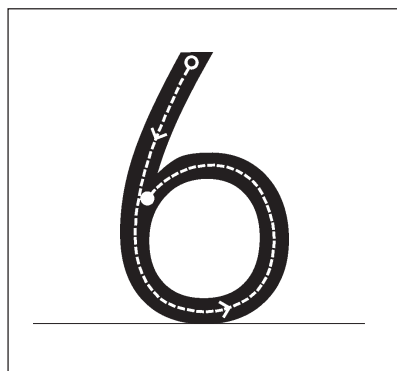

I can count 6 bags.



Cut and stick   or draw  6 hats.



Write 

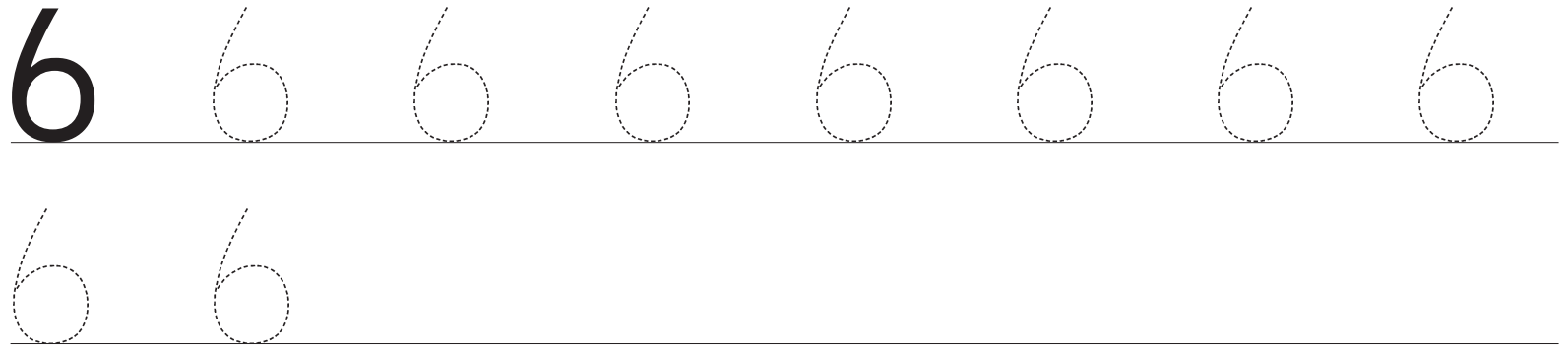
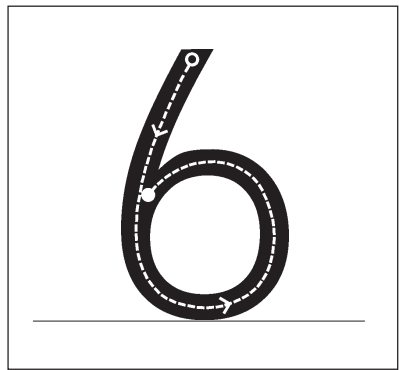

I can count 7 cakes.



Cut and stick   or draw  7 apples.

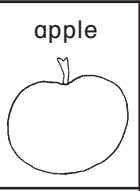

Write 

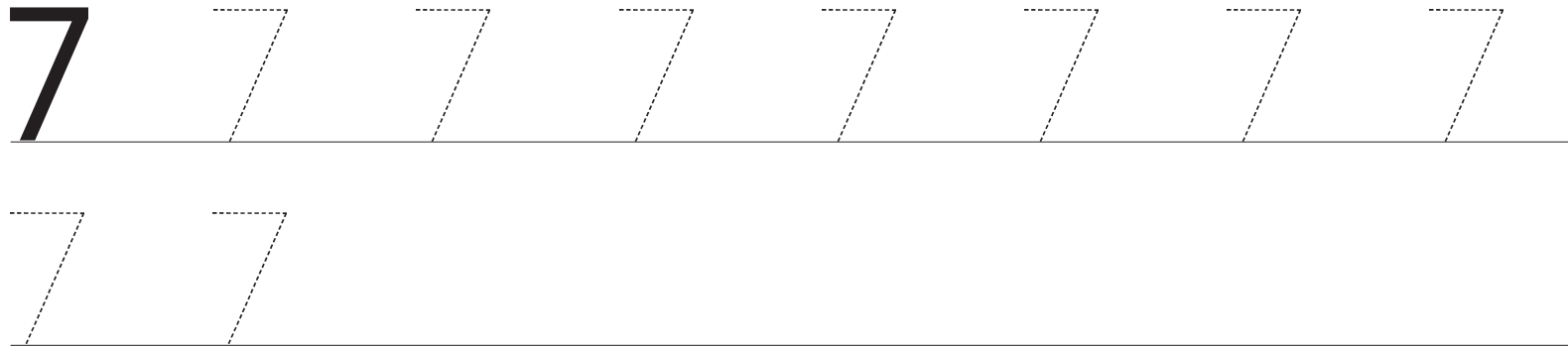
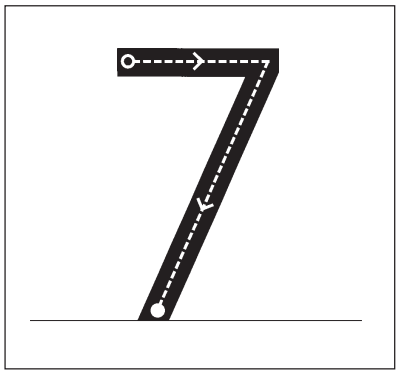

I can count 7 ducks.



Cut and stick   or draw  7 fish.

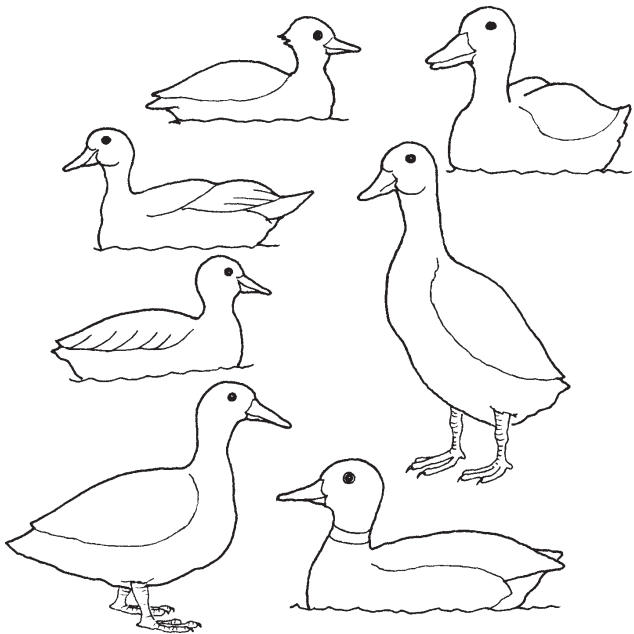
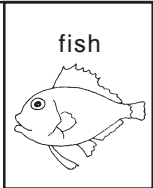

Write 

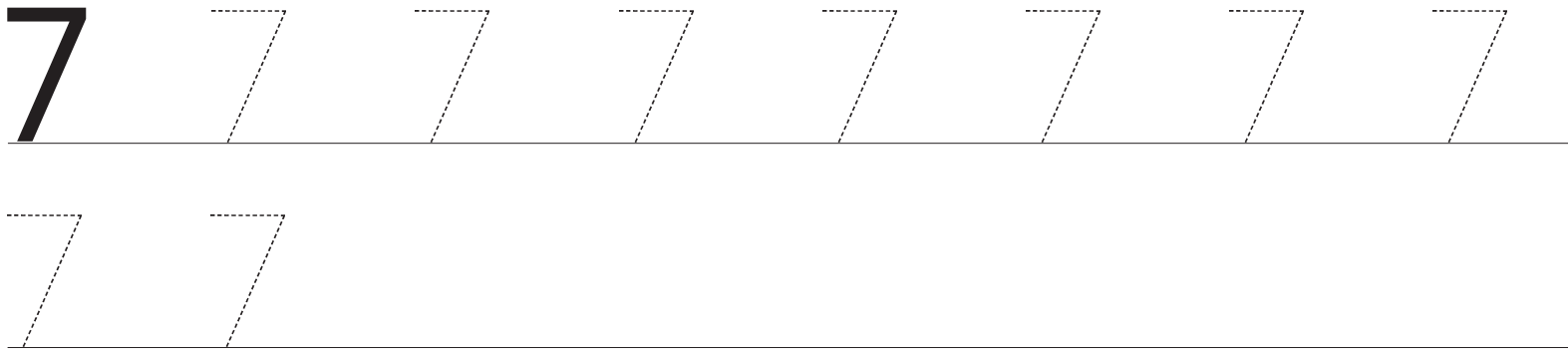
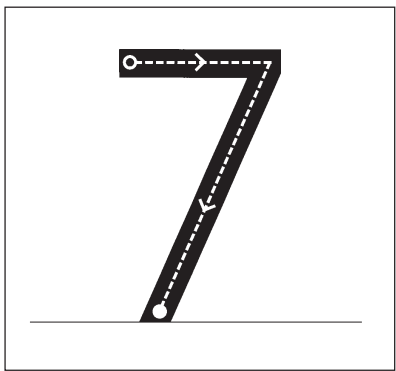

I can count 7 hedgehogs.

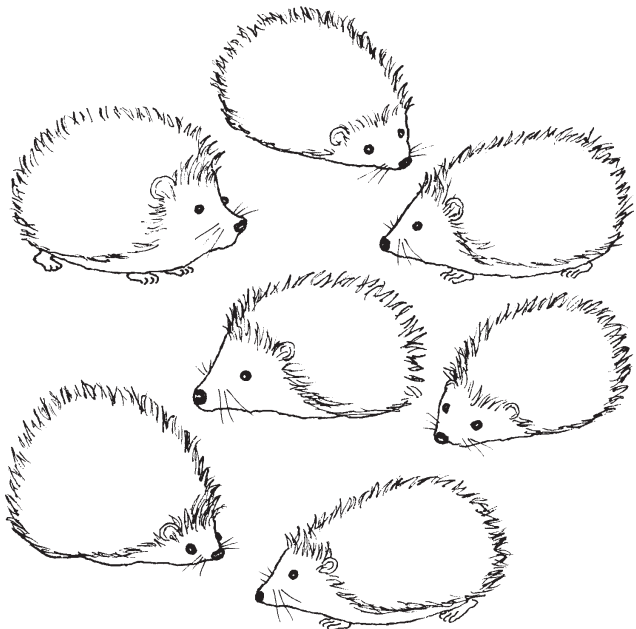

Cut and stick   or draw  7 rabbits.



Write 

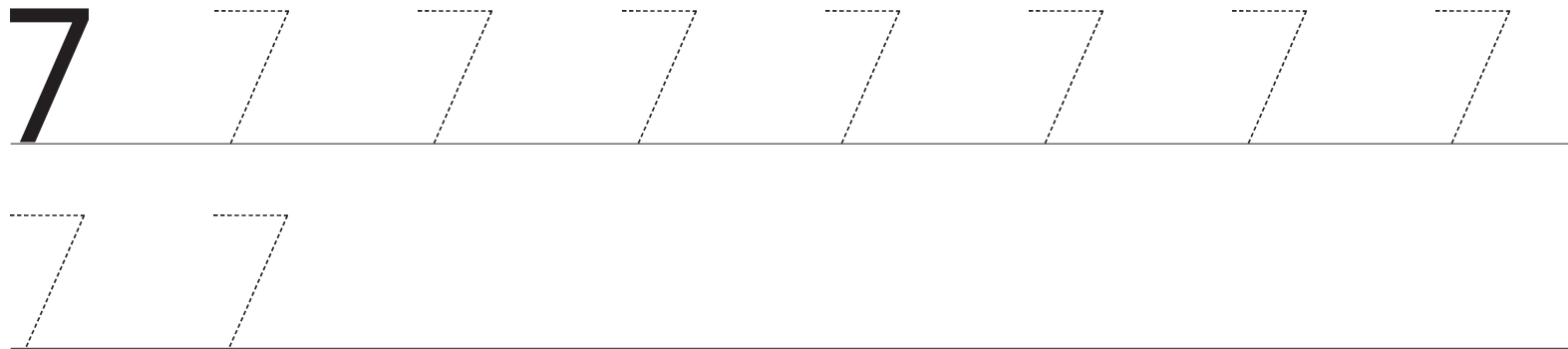
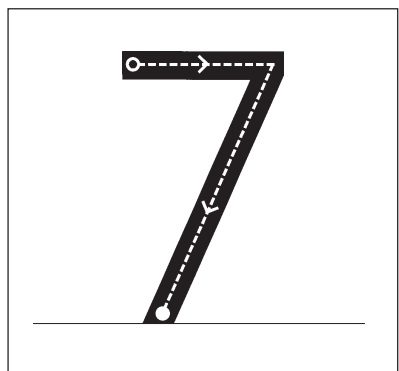

I can count 8 sheep.

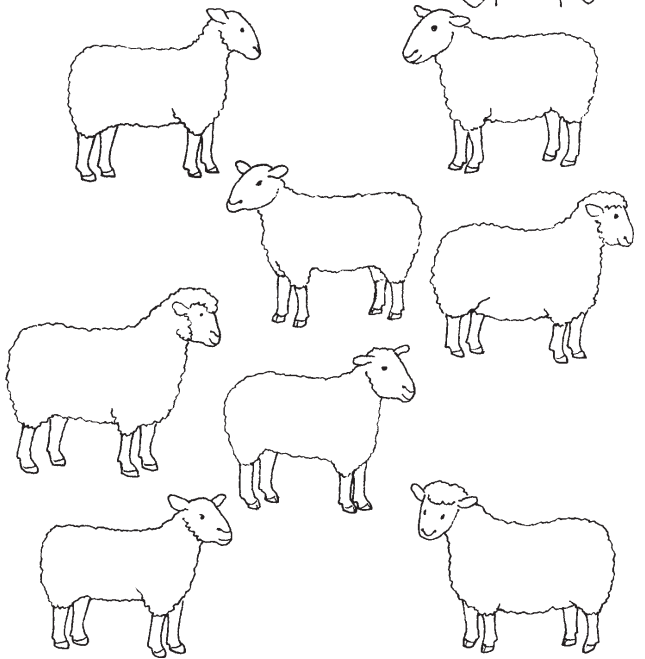

Cut and stick   or draw  8 pigs.

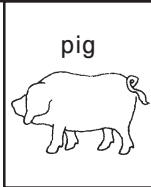

Write 

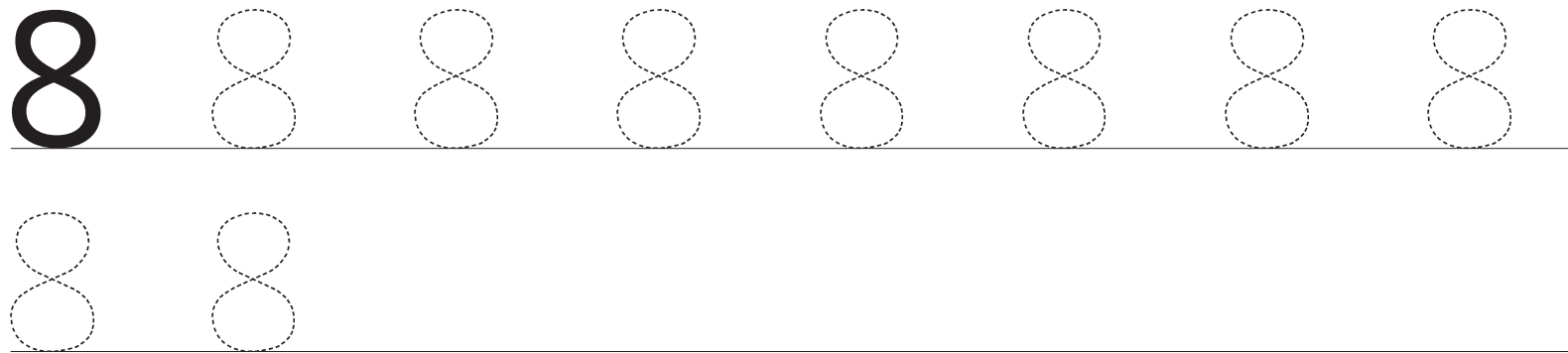
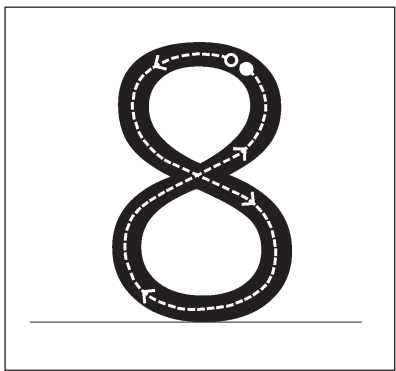

I can count 8 stars.

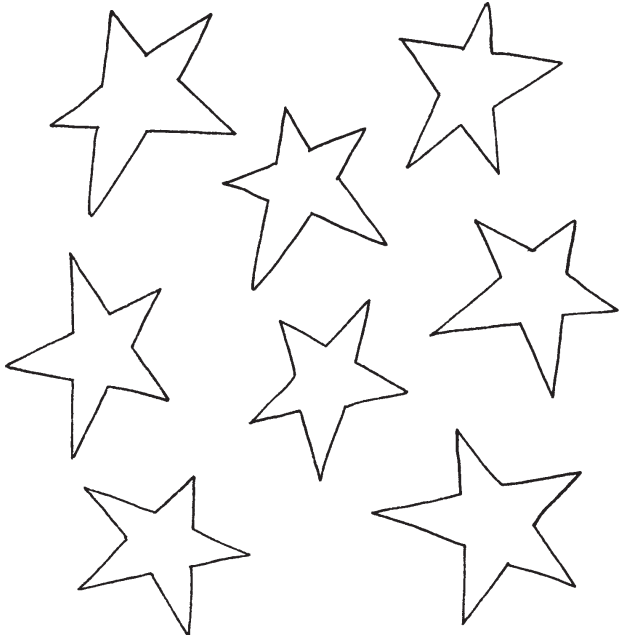

Cut and stick   or draw  8 suns.

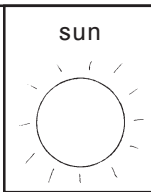

Write 

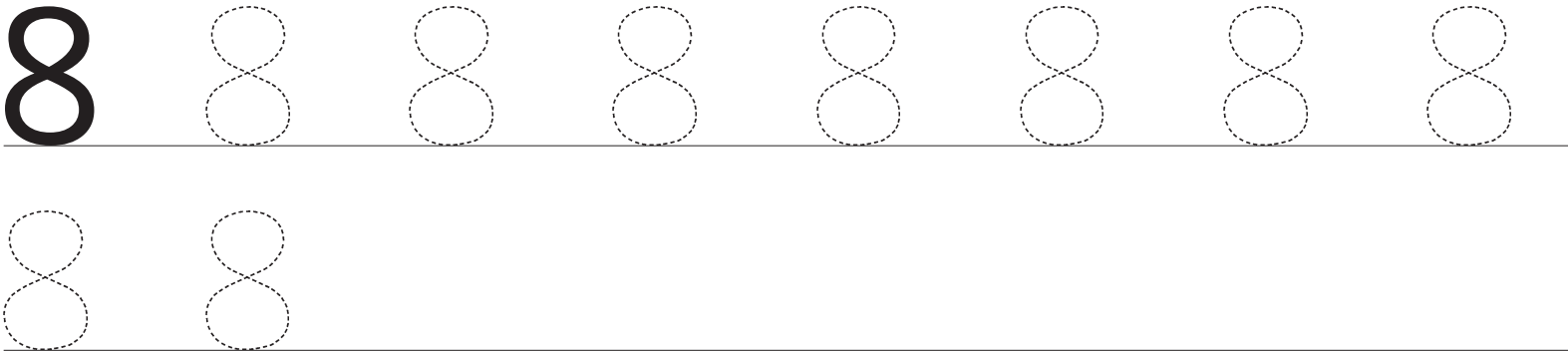
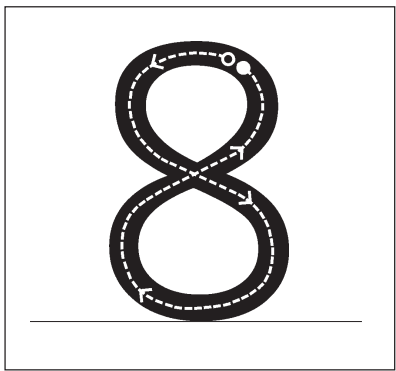

I can count 8 windows.

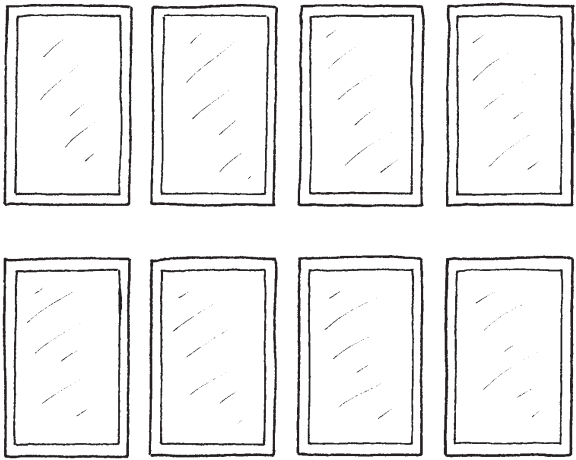

Cut and stick   or draw  8 doors.

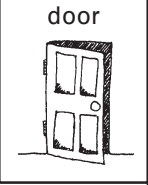

Write 

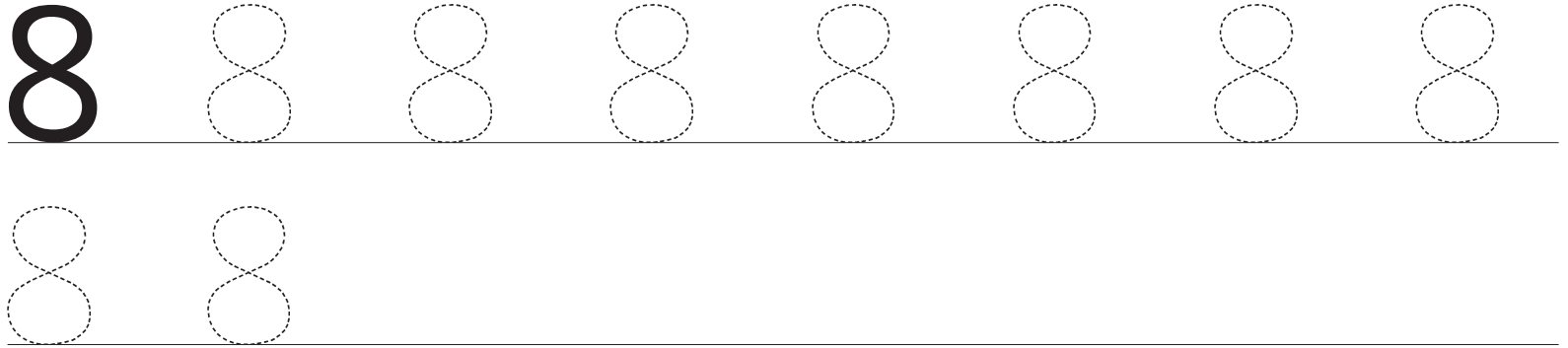
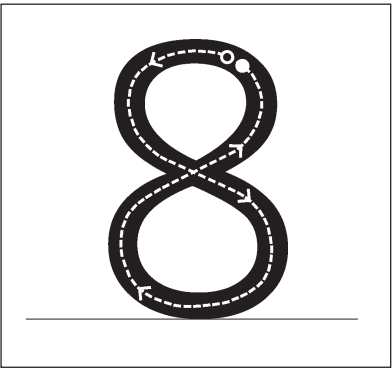

I can count 9 flowers.



Cut and stick   or draw  9 hearts.

heart

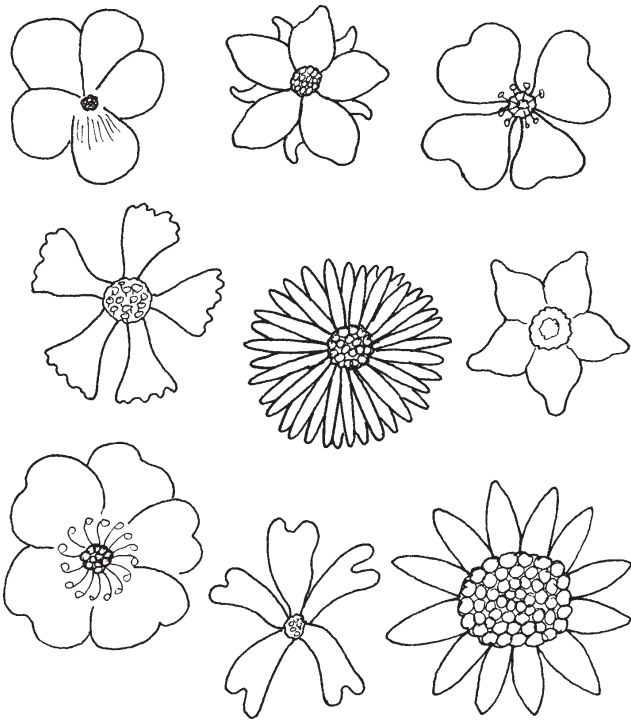

Write

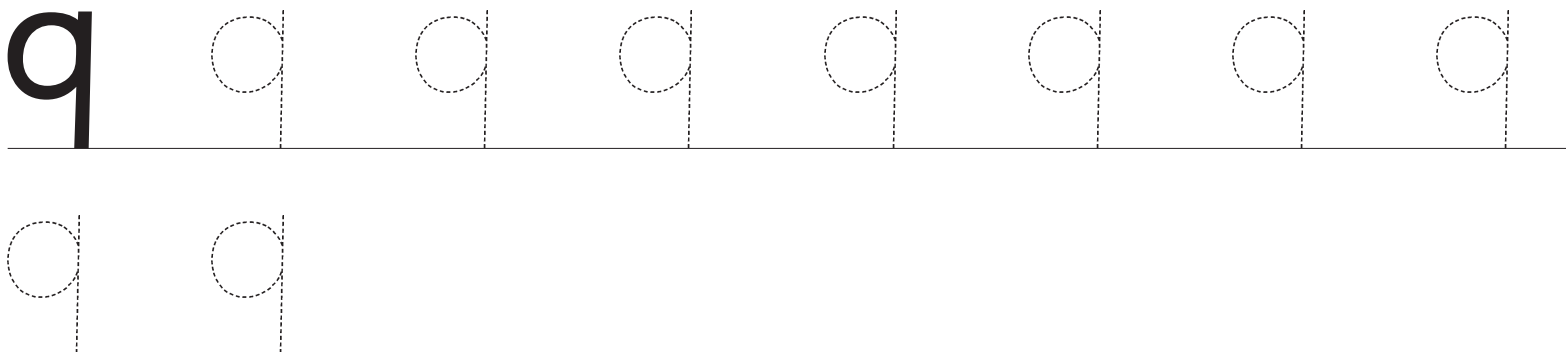
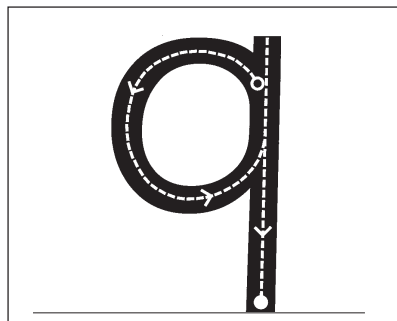

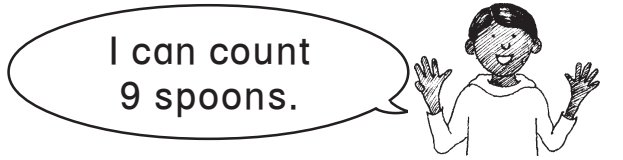

Cut and stick   or draw  9 cups.

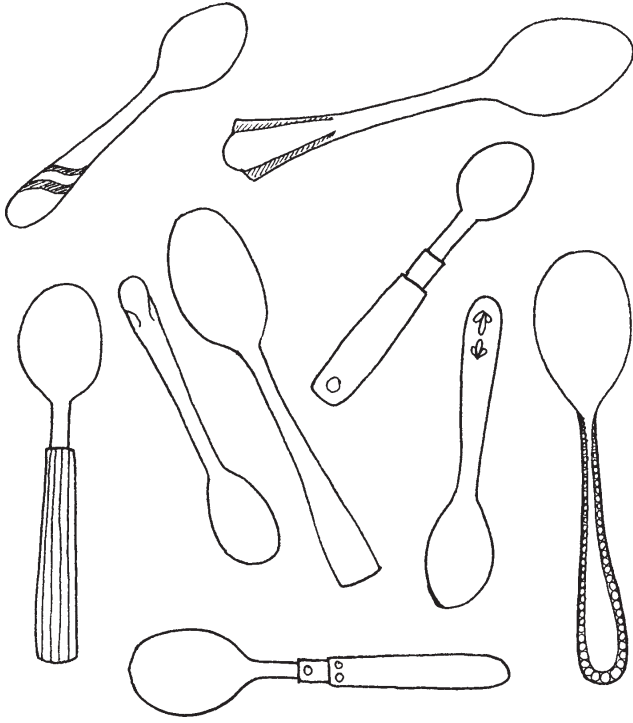

Write 

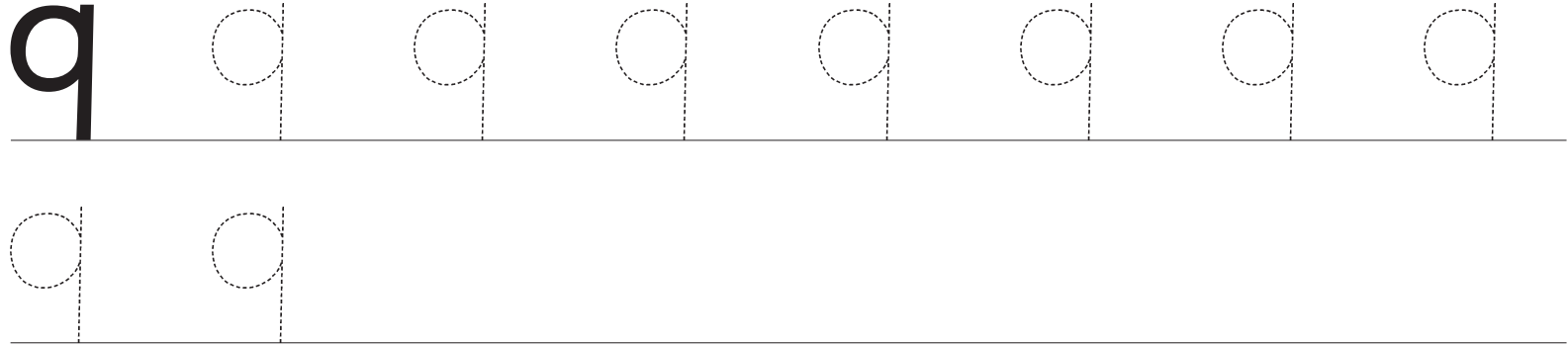
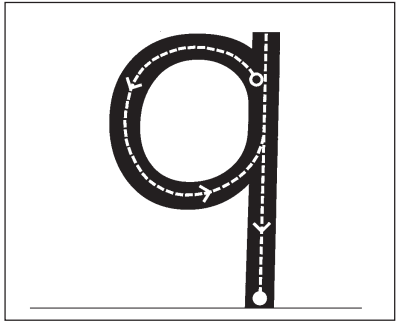

I can count 9 frogs.

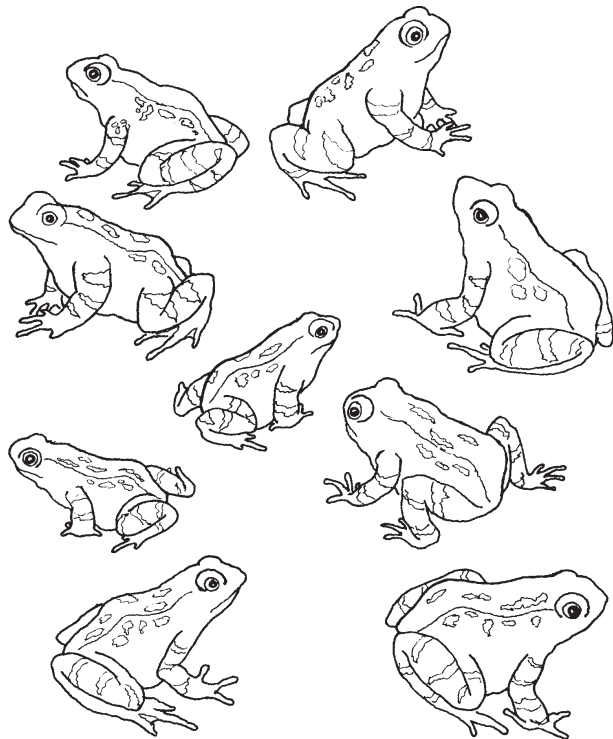

Cut and stick   or draw  9 snakes.



Write 

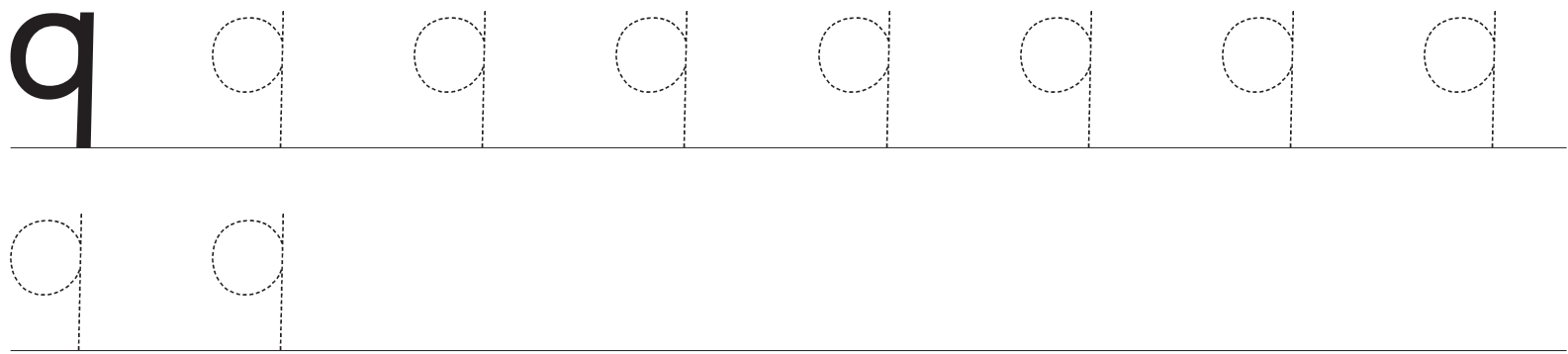
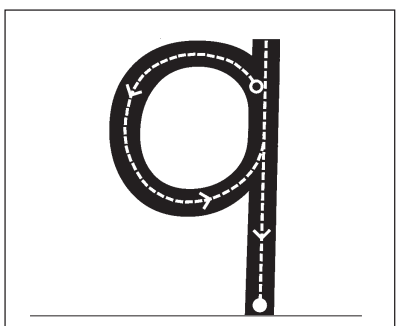

I can count 10 butterflies.

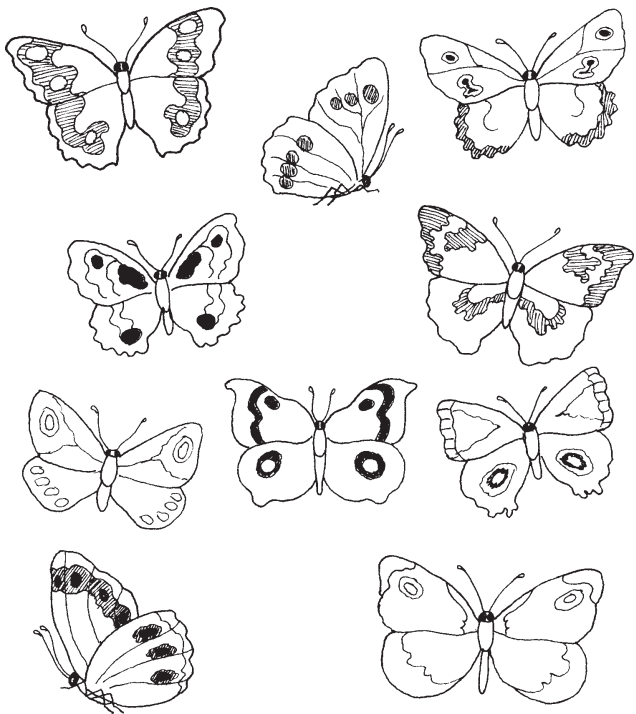

Cut and stick   or draw  10 bees.

bee



Write 

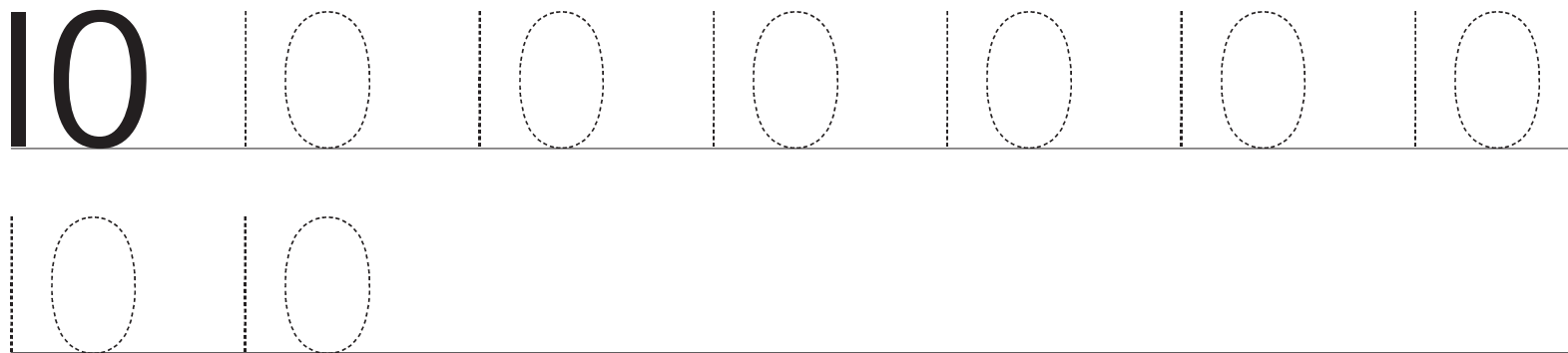
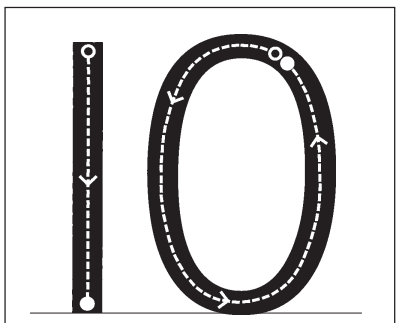

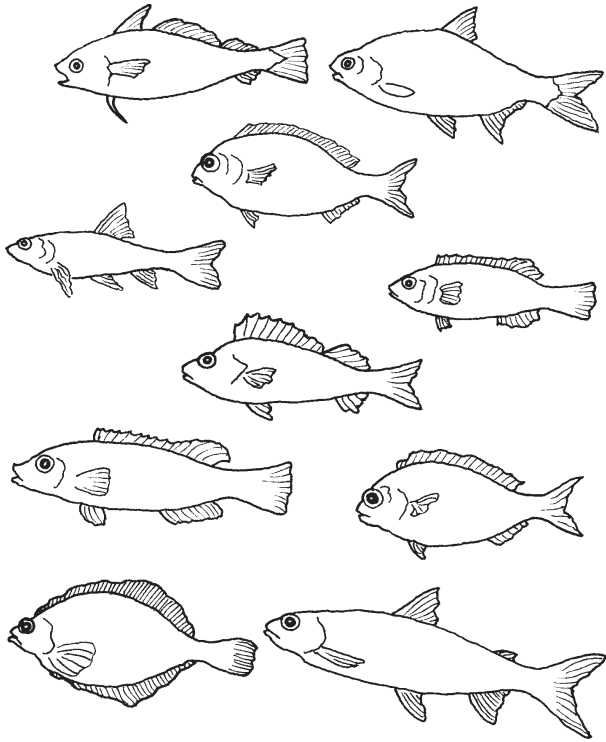
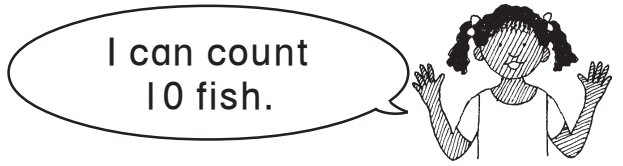

Cut and stick   or draw  10 ducks.

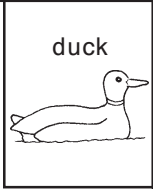

Write 

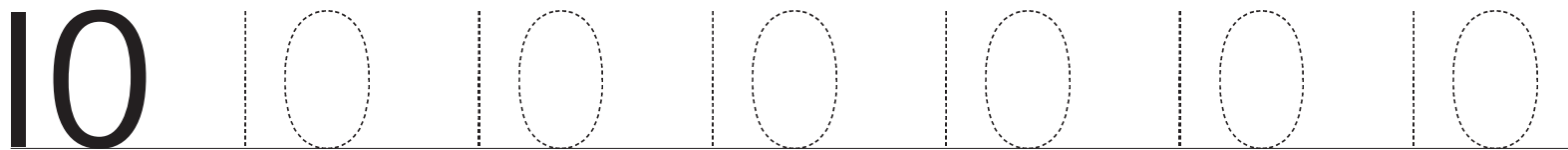
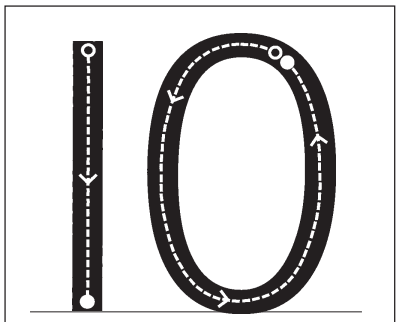

I can count 10 balls.

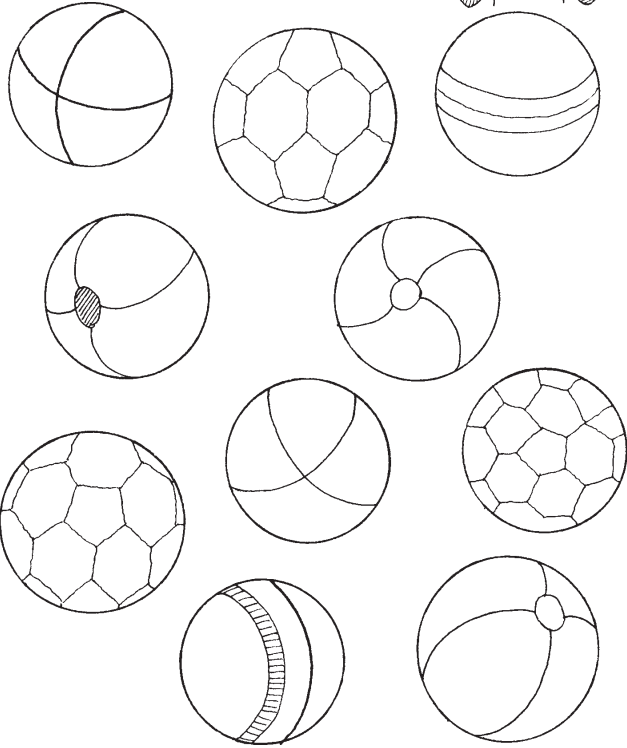

Cut and stick   or draw  10 balloons.

balloon



Write 

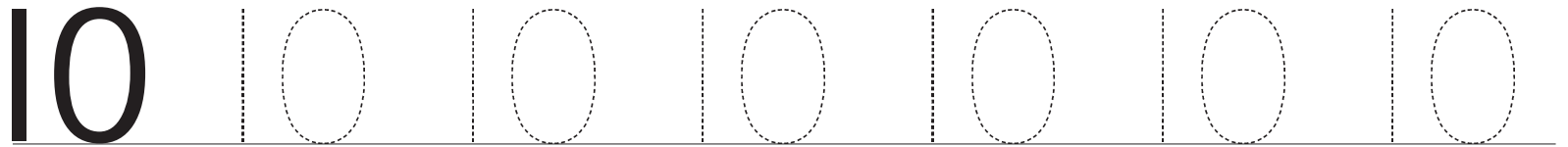
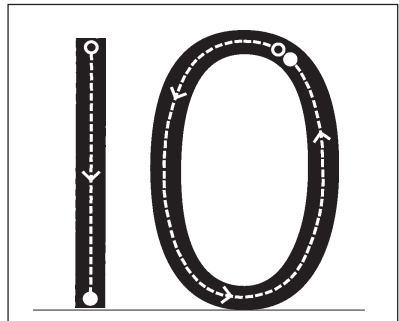

Alternative Number Formation

NOTES FOR TEACHERS

The following sheets are for cutting and pasting onto sheets where you prefer a different number formation. For example, if you prefer a 1 number one, rather than the straight 1 we have used, then cut out the three strips on page 32 and stick them to pages 1, 2 and 3.

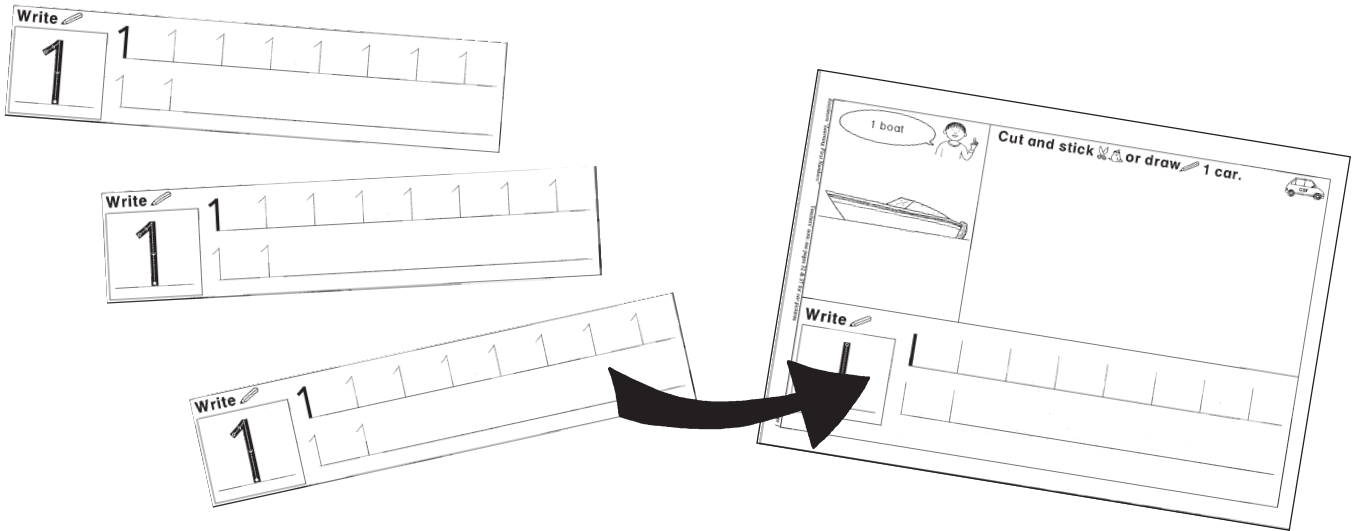

Alternative Formations Available

<u>Version used on worksheets</u>	<u>Alternative available</u>	<u>Page</u>
1	1	32
4	4	33
6	6	34
10	10	35

Please note: we have no objection to **your** altering the numbers on the actual pages to suit your method of number formation.

Write

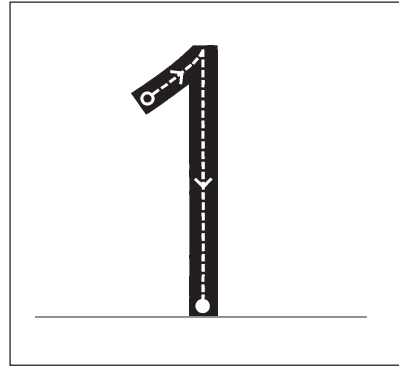

1

1

1

1

1

1

1

1

1

1

1

Write

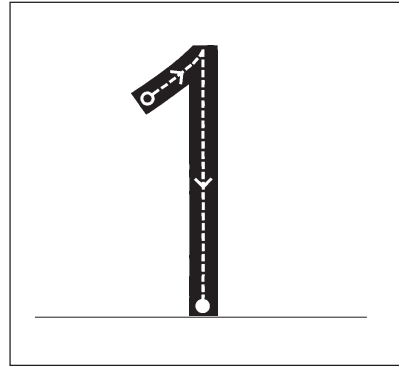

1

1

1

1

1

1

1

1

1

1

1

Write

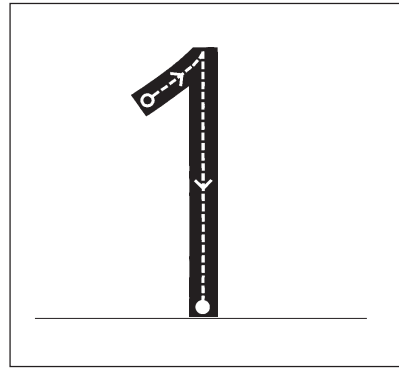

1

1

1

1

1

1

1

1

1

1

1

Write

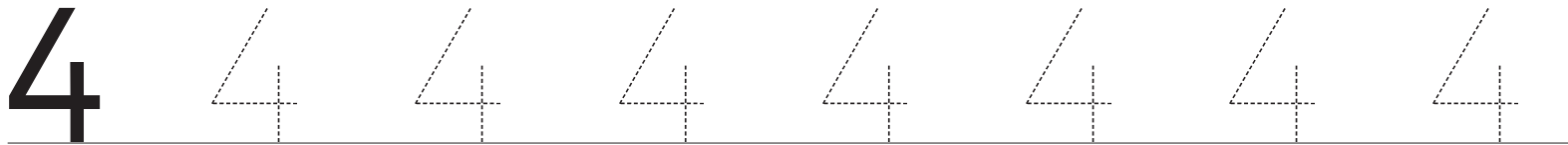
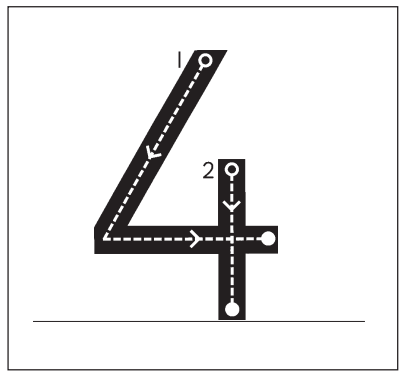

Write

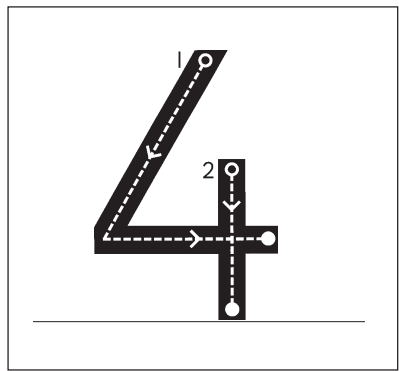

Write

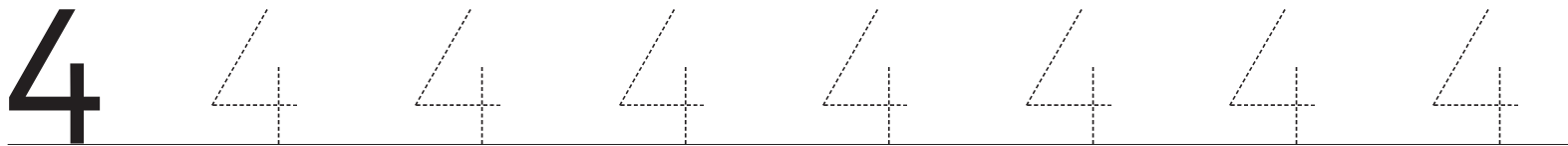
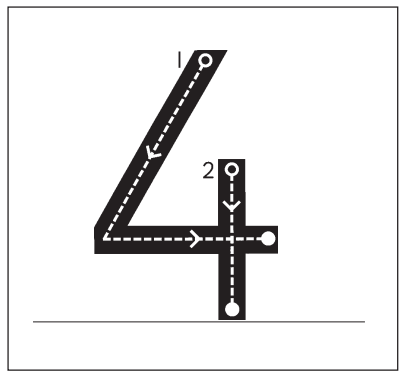

Write



6

6

6

6

6

6

6

6

6

6

Write



6

6

6

6

6

6

6

6

6

6

Write

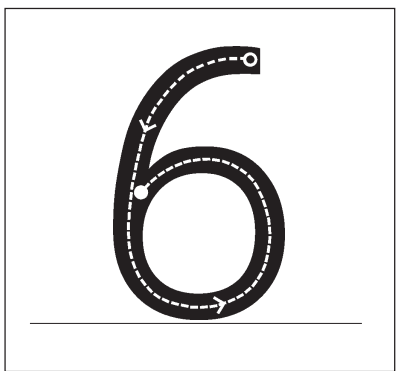

6

6

6

6

6

6

6

6

6

6

Write

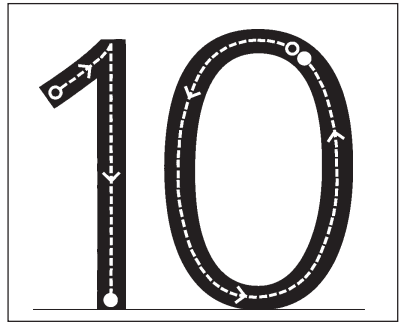

10 10 10 10 10 10 10

10 10

Write

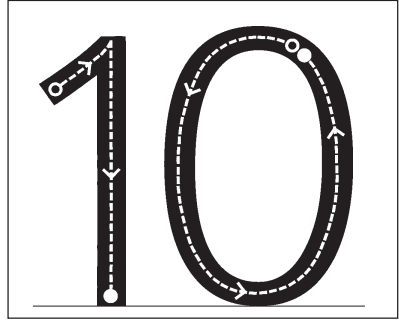

10 10 10 10 10 10 10

10 10

Write

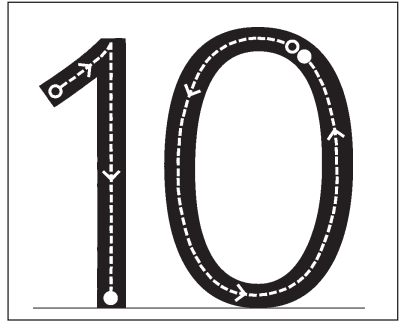

10 10 10 10 10 10 10

10 10

How to use the Picture Pages

NOTES FOR TEACHERS

Picture pages (pages 37 to 56) can be used in conjunction with pages 1 to 30. The teacher selects a picture page for the pupil to use with the *cut & stick* activity on each number page (pages 1 to 30).

Please note:

1. A *teachers' note* appears on each page of the book, telling you which picture pages to use with which worksheets and vice versa.
2. Pages 37 to 41 have 3 x 6 objects per page and are only for use with pages 1 to 15 (numbers 1 to 5). The objects on these picture sheets are the same ones as on pages 42 to 49.
3. The space for the *cut & stick* activity becomes more limited for larger numbers. Children will need to stick pictures on carefully on pages 25 to 30.
4. For some children, or on some occasions, teachers may prefer to cut out pictures beforehand and have 'stores' of objects ready.
5. There are 30 different objects on these picture pages.
6. A blank box appears at the top of each picture page. This is for you to add instructions, should you wish to create worksheets with those pages. If making worksheets and adding instructions, you may find the small pictures on page 57 useful.

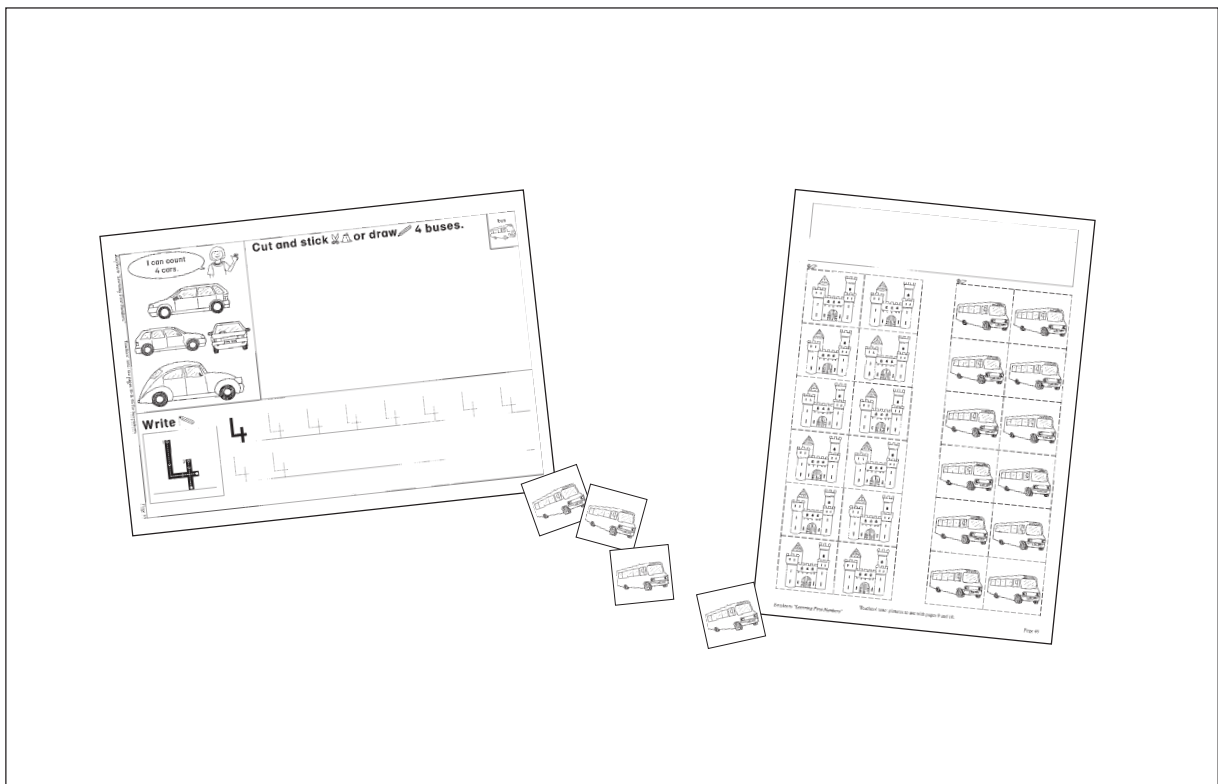

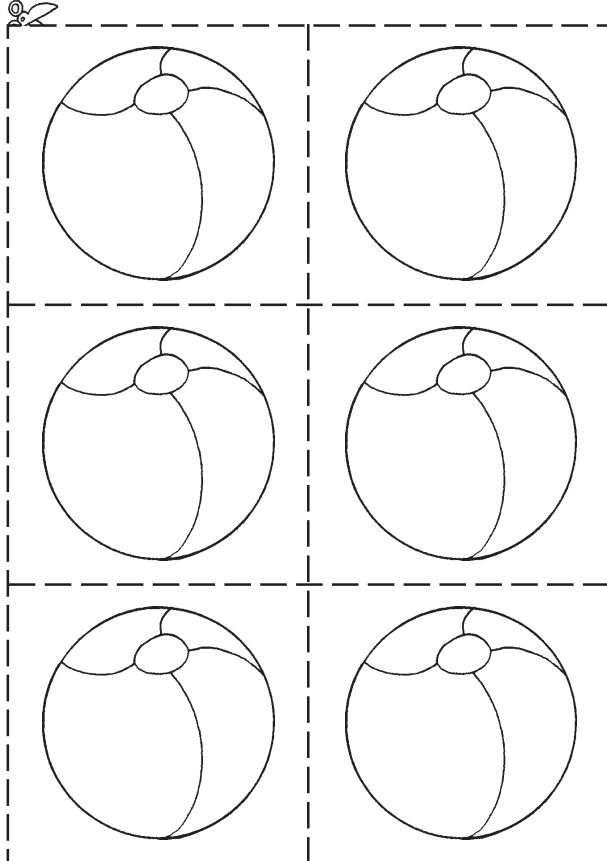
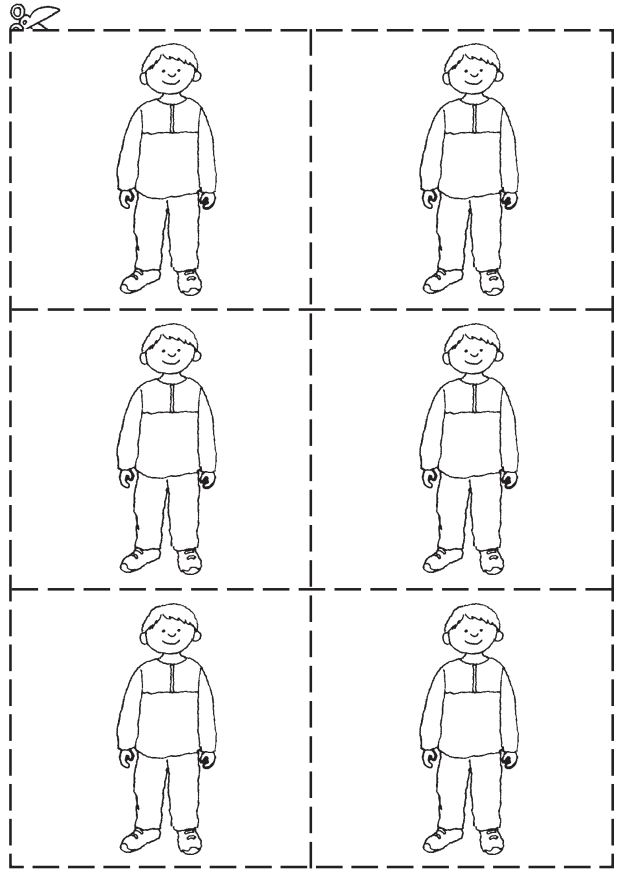
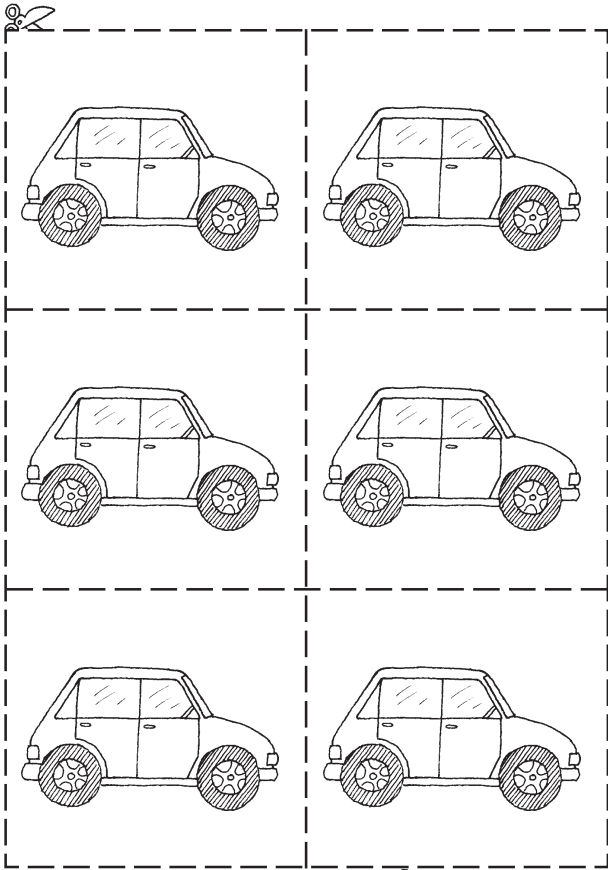

Teachers' note: pictures to use with pages 1 to 3.

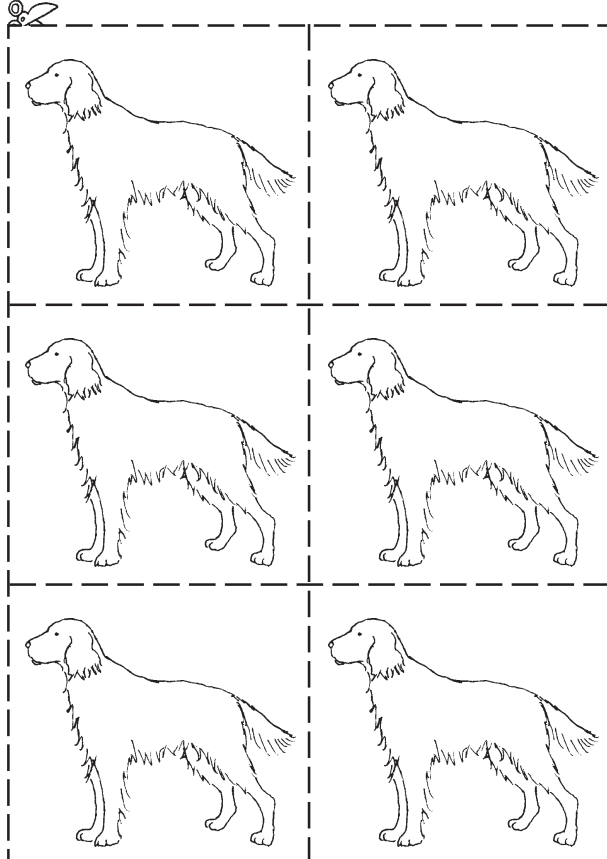
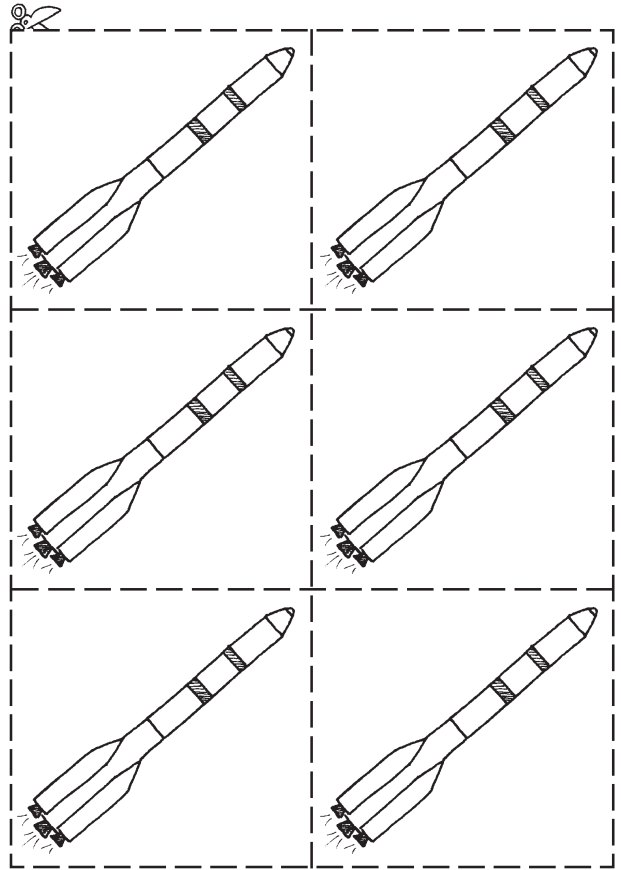
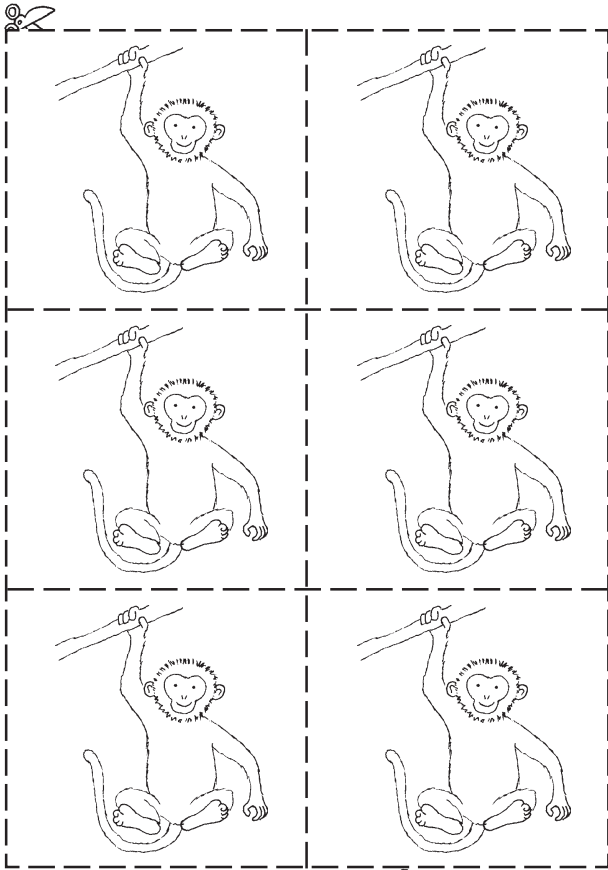

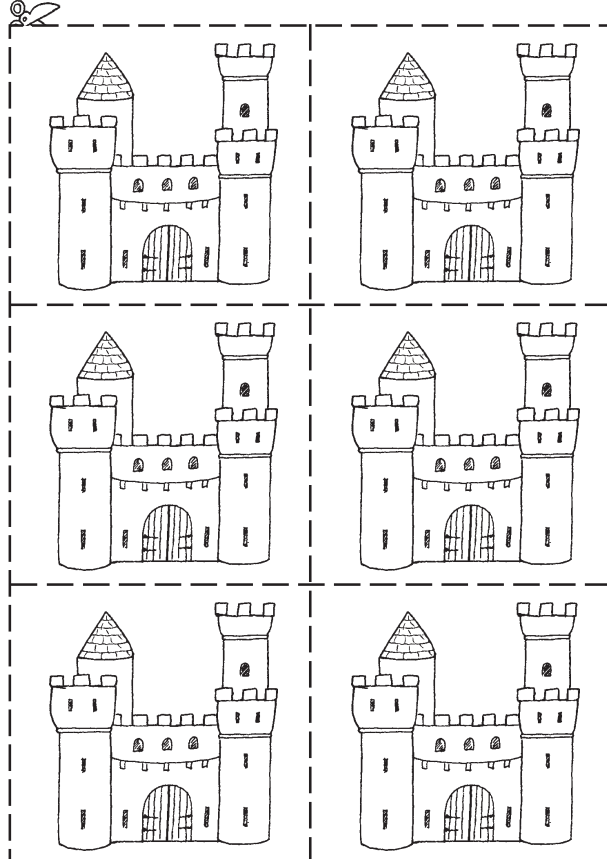
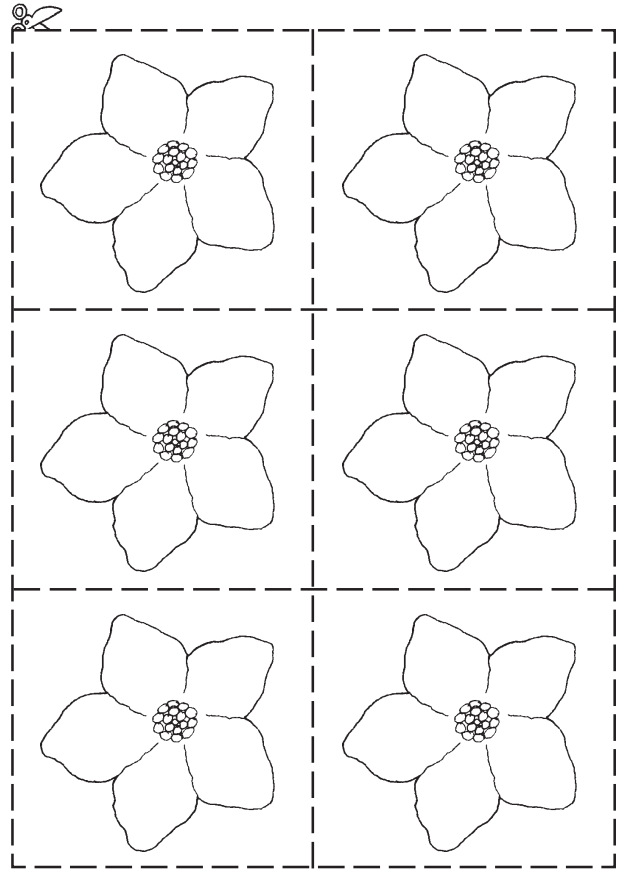
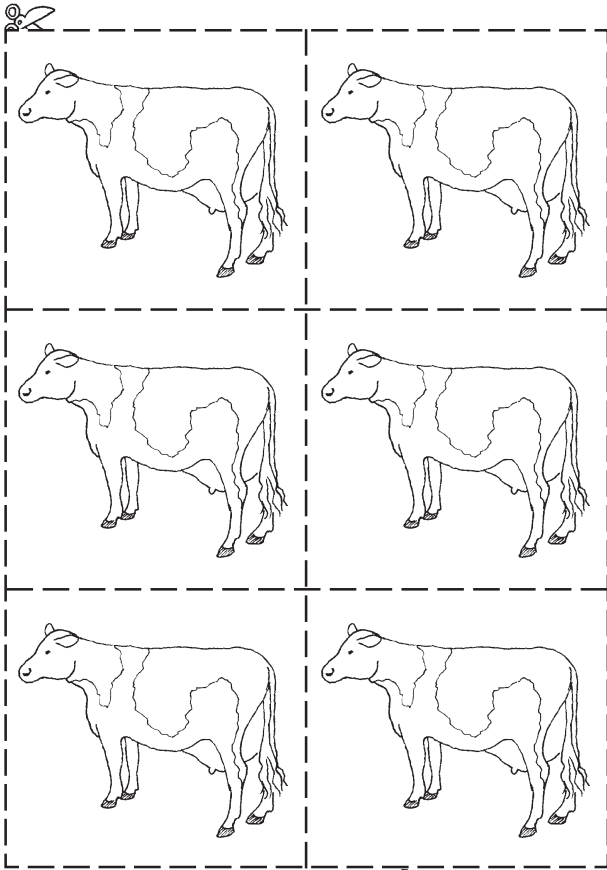

Teachers' note: pictures to use with pages 7 to 9.

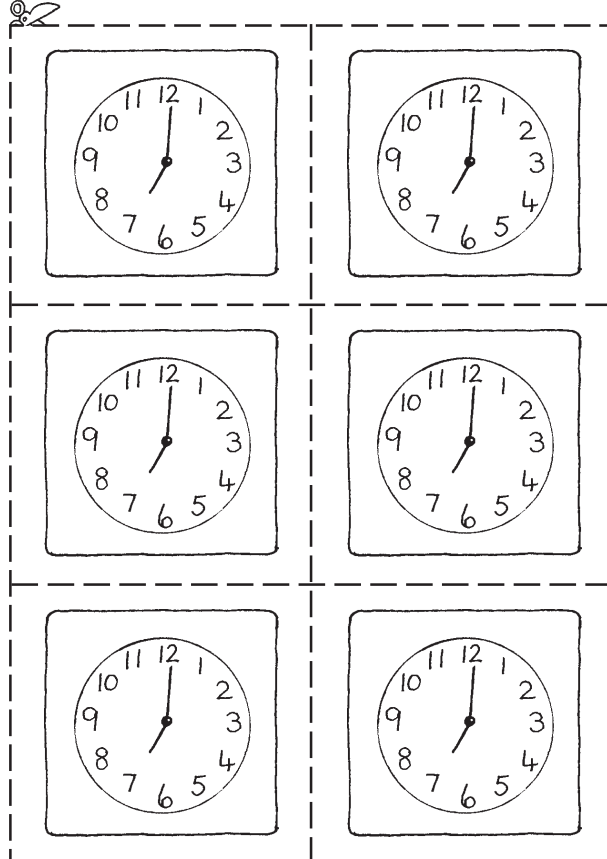
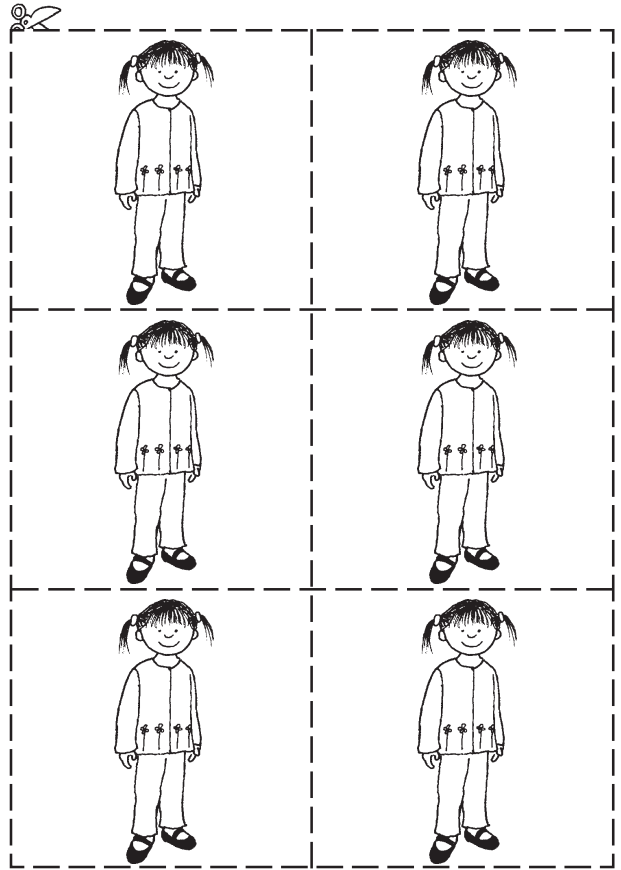
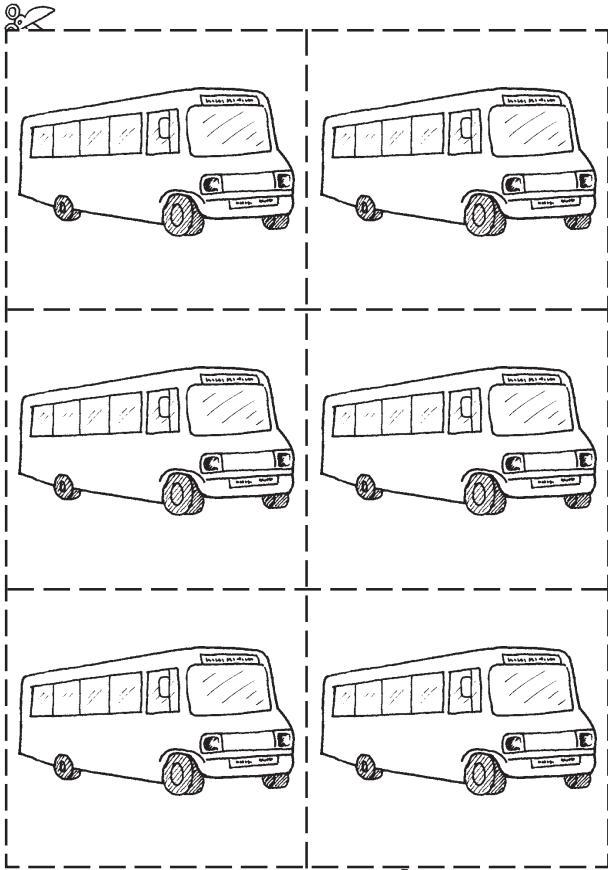

Teachers' note: pictures to use with pages 10 to 12.

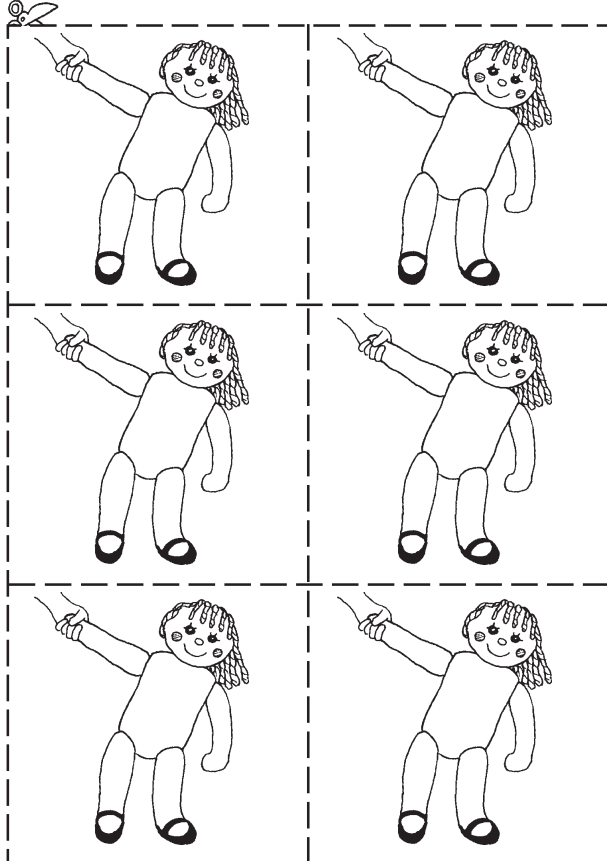
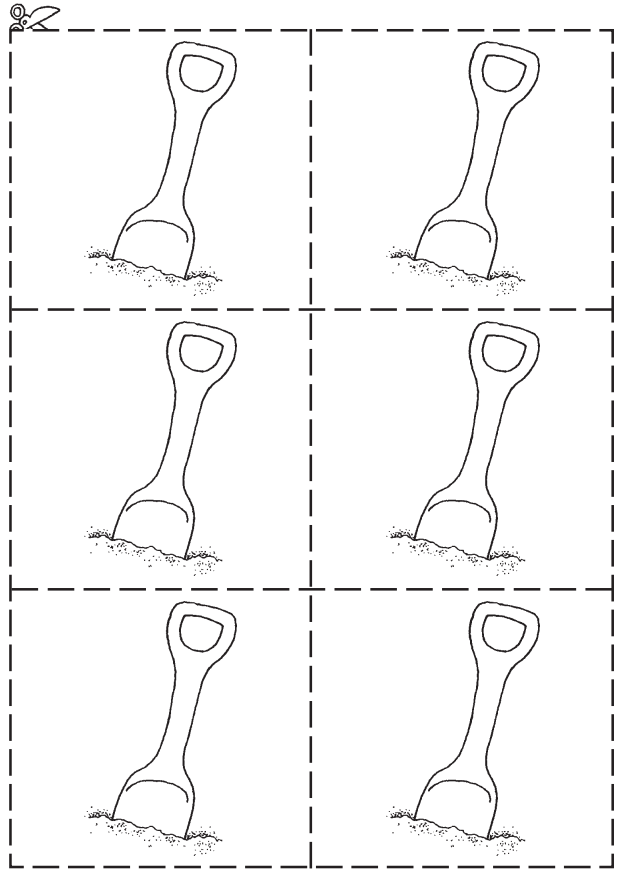
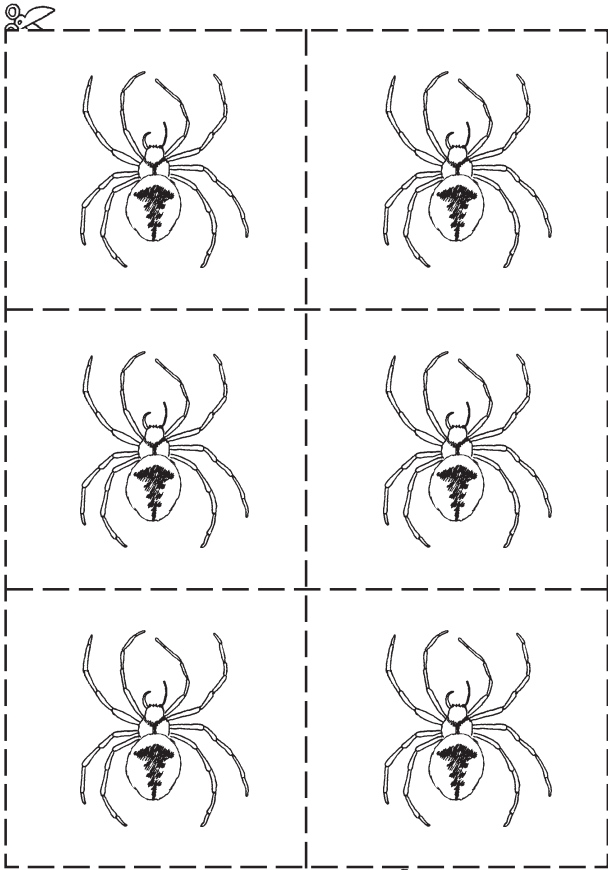
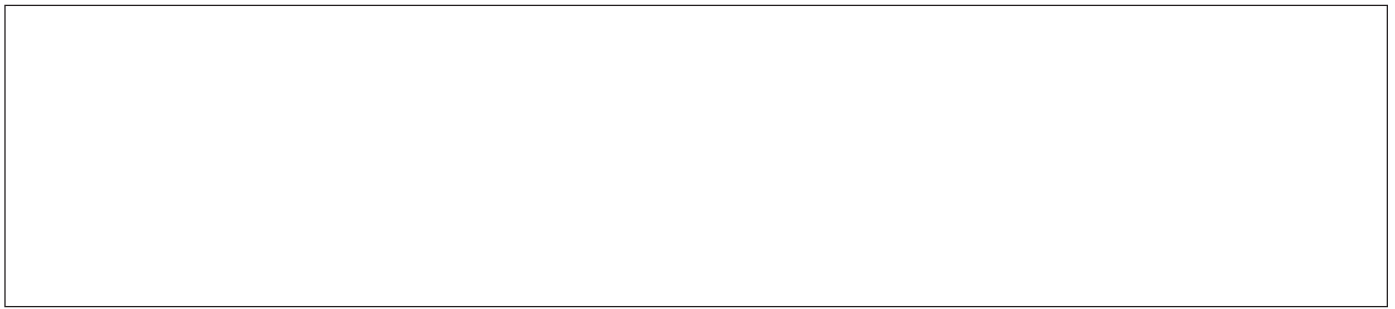

Teachers' note: pictures to use with pages 13 to 15.

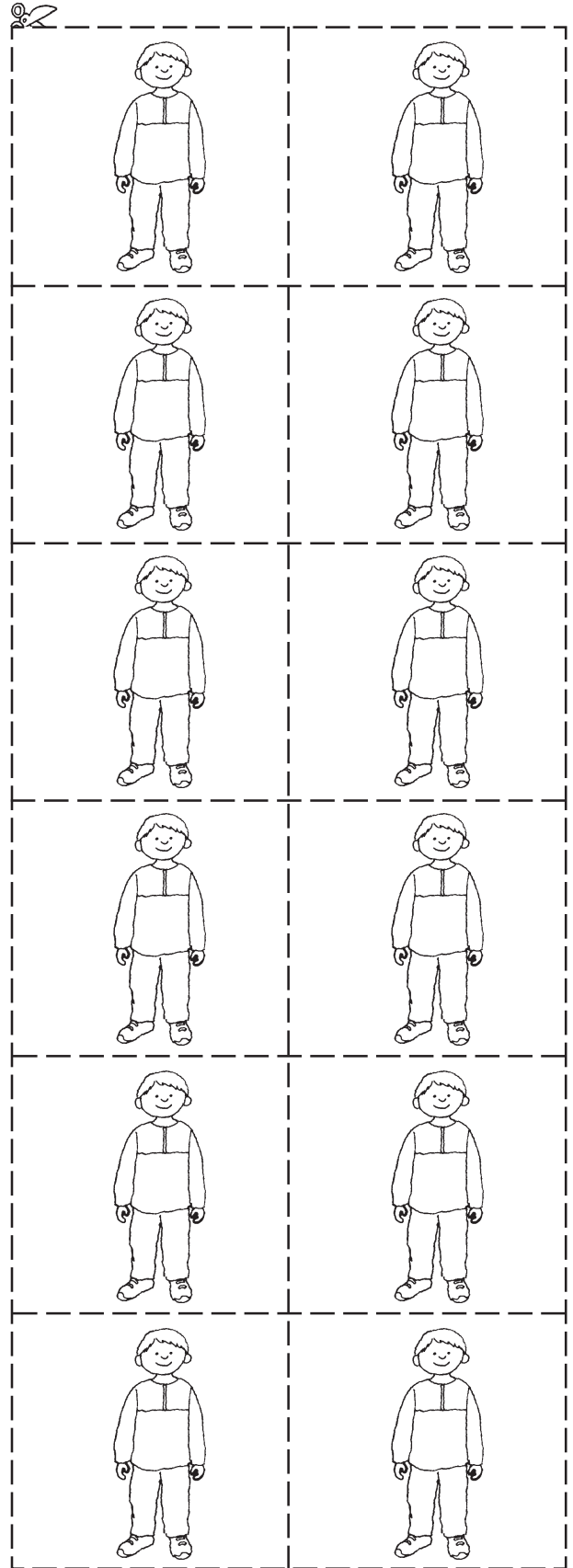
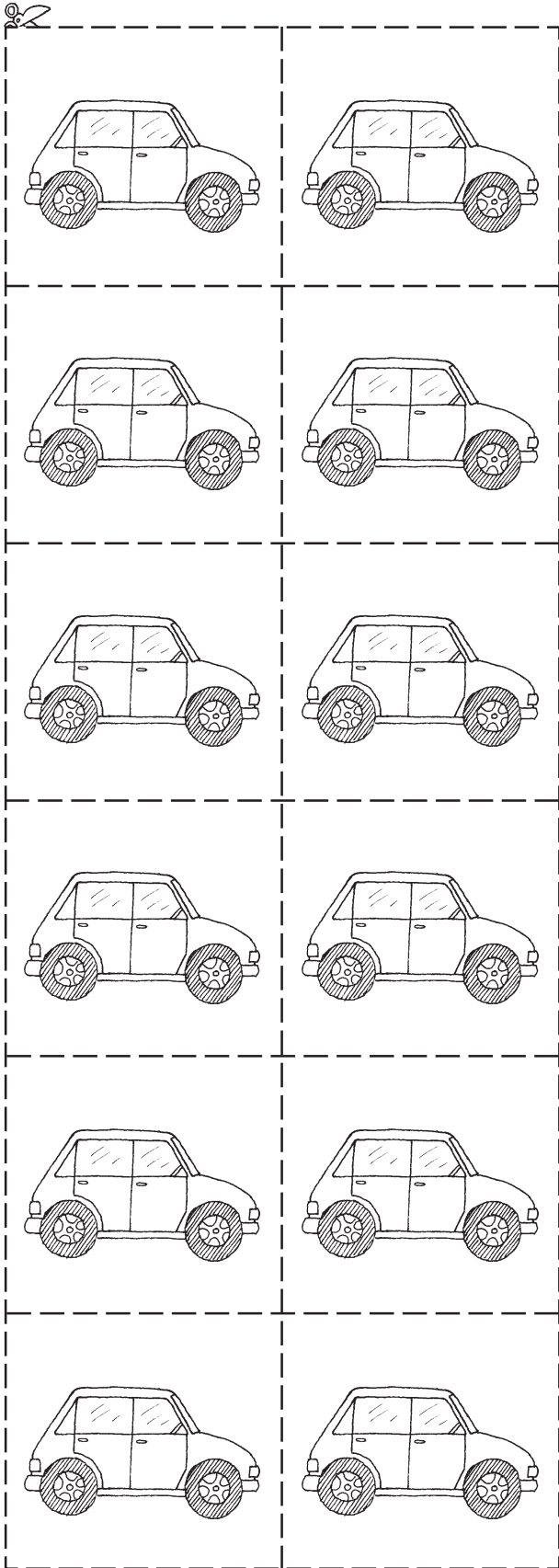
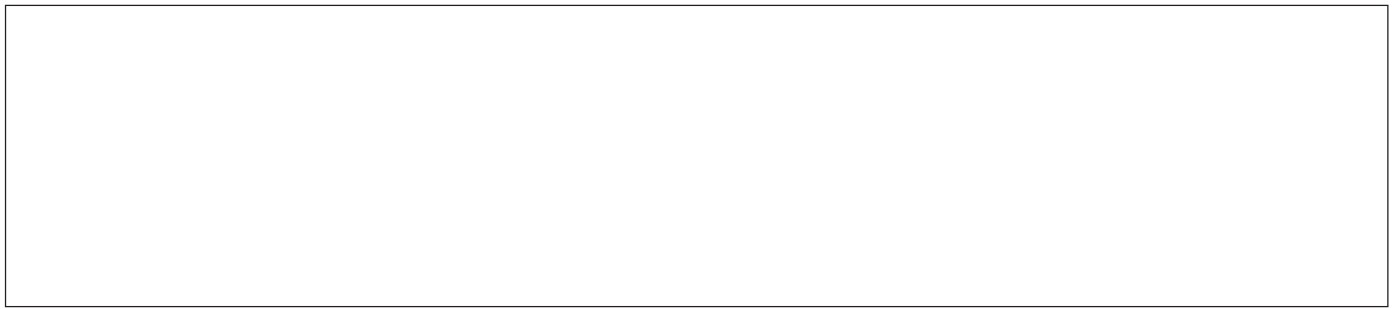

Teachers' note: pictures to use with pages 1 and 2.

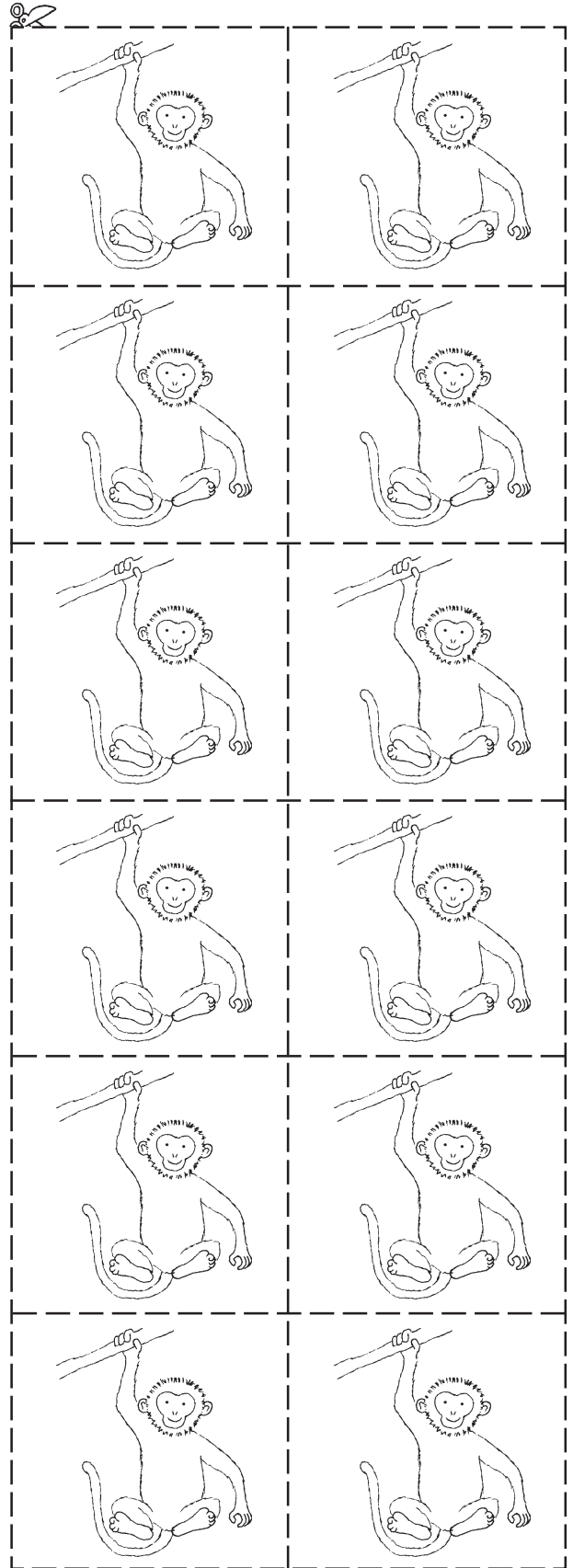
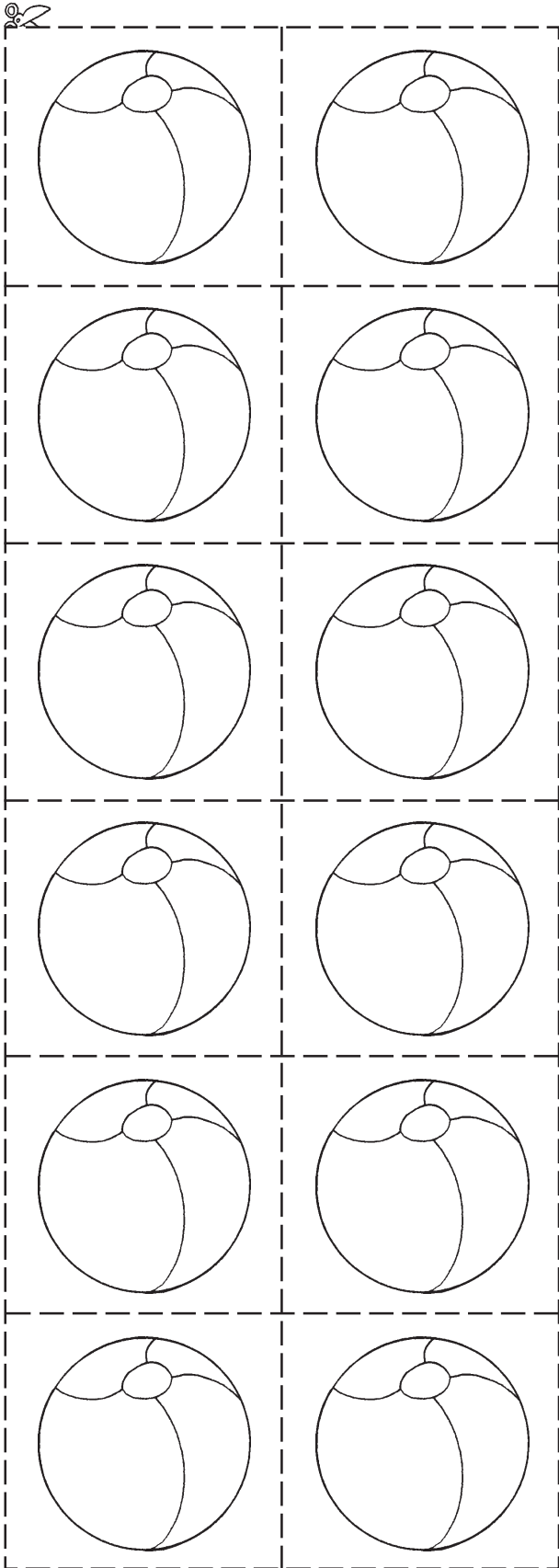
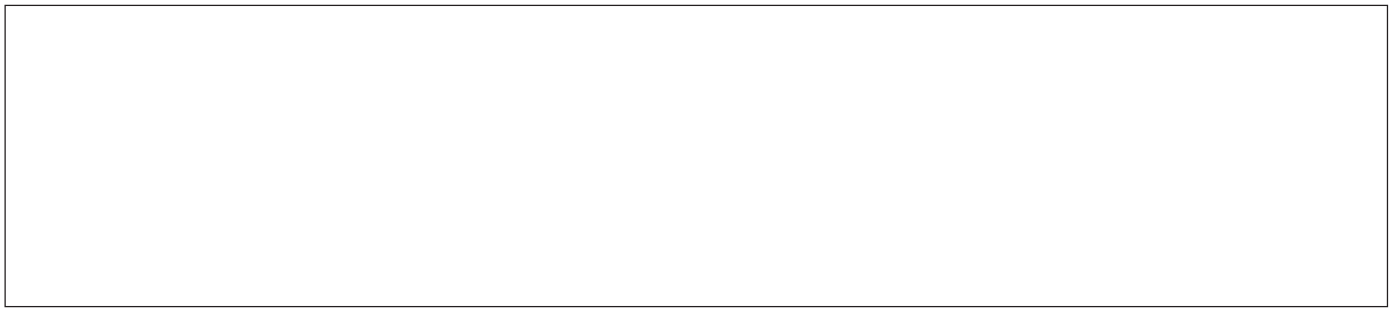

Teachers' note: pictures to use with pages 3 and 4.

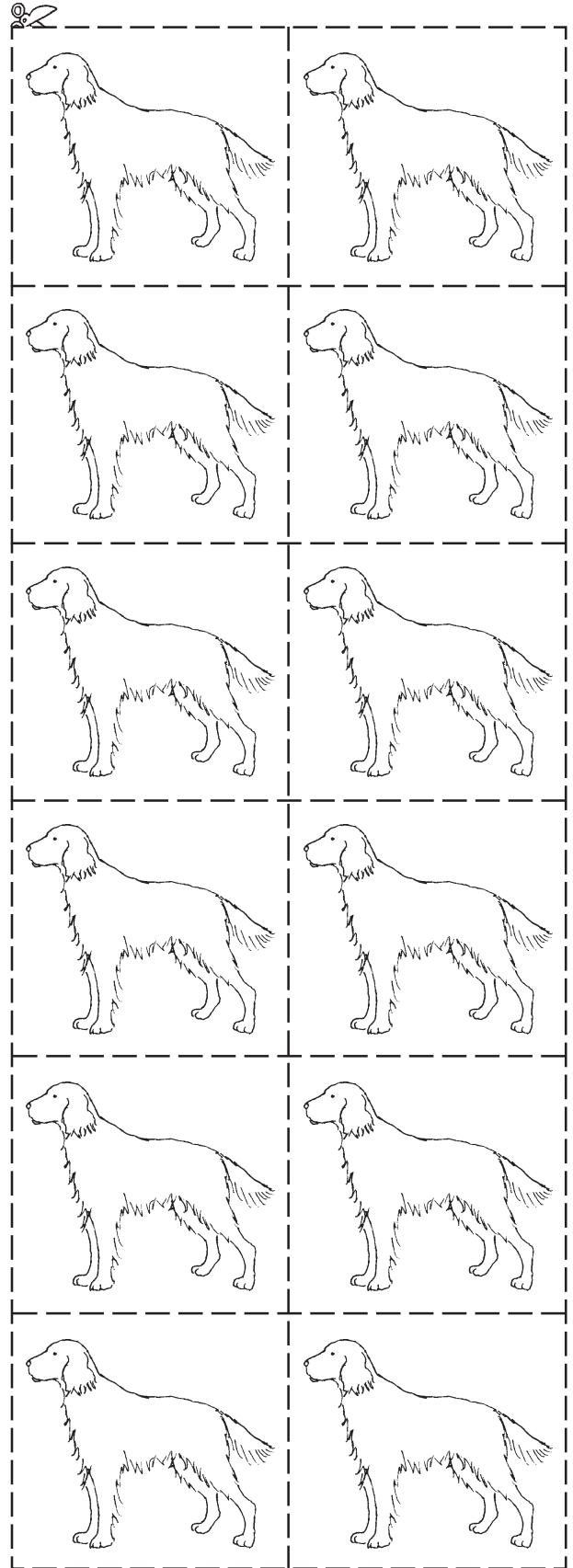
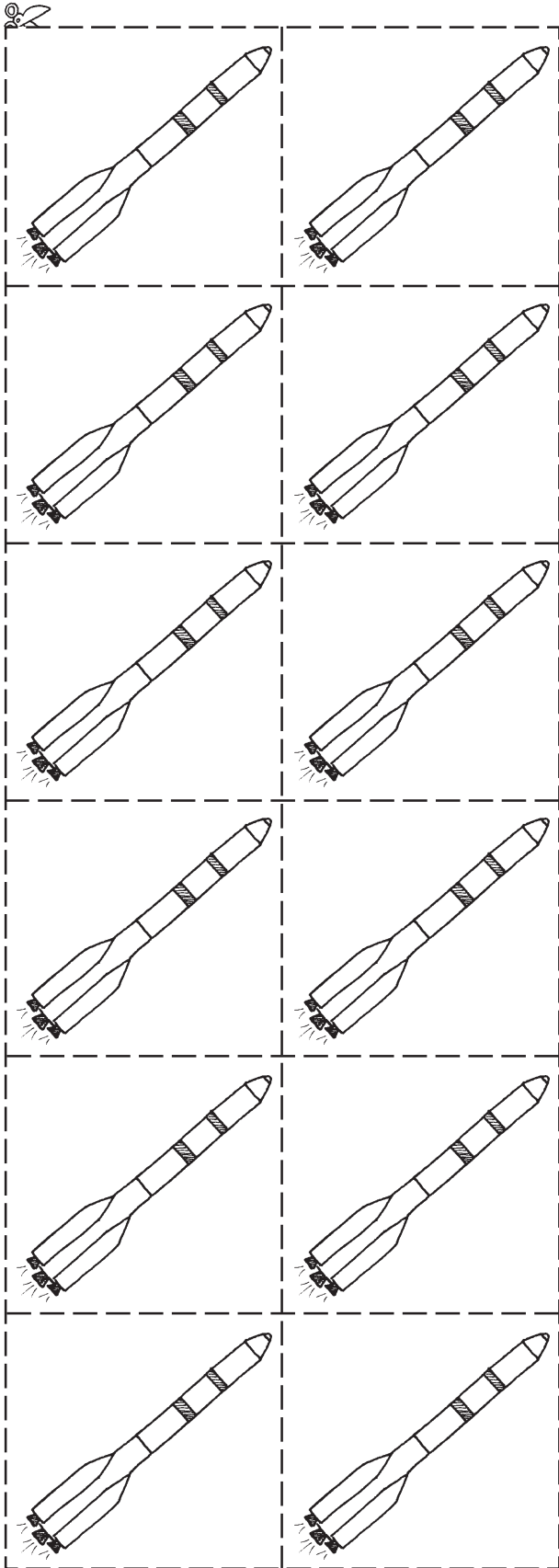

Teachers' note: pictures to use with pages 5 and 6.

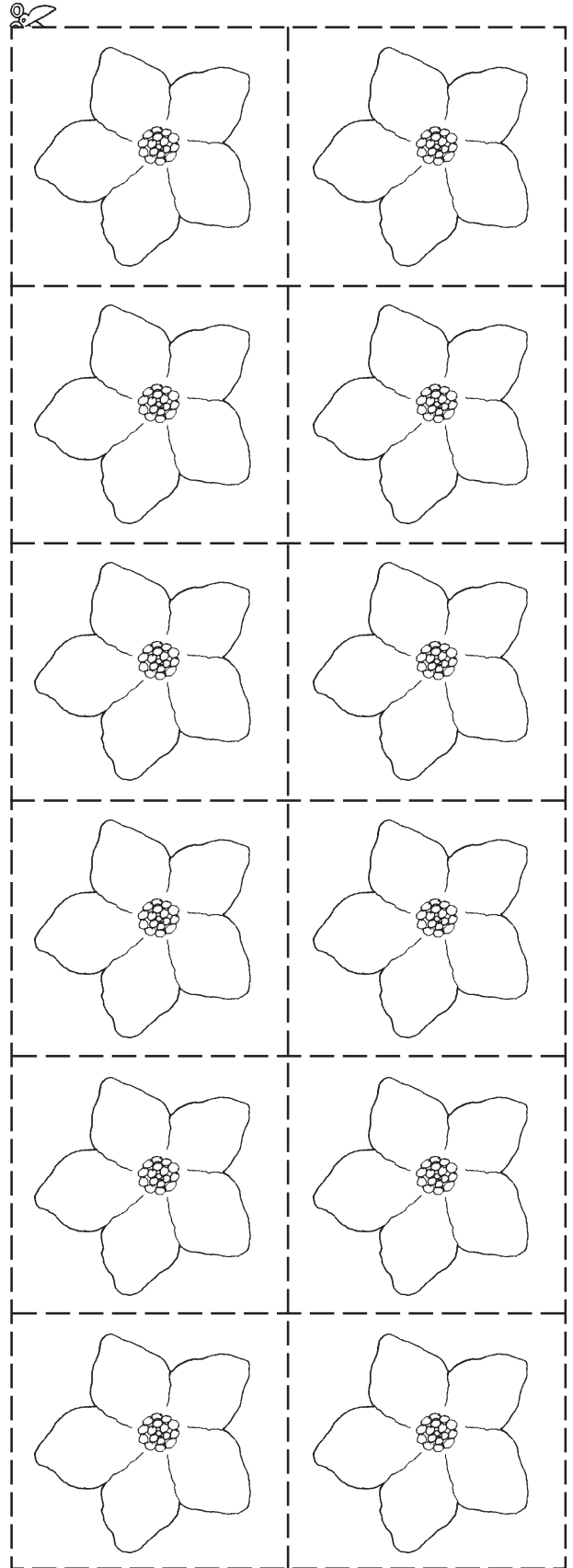
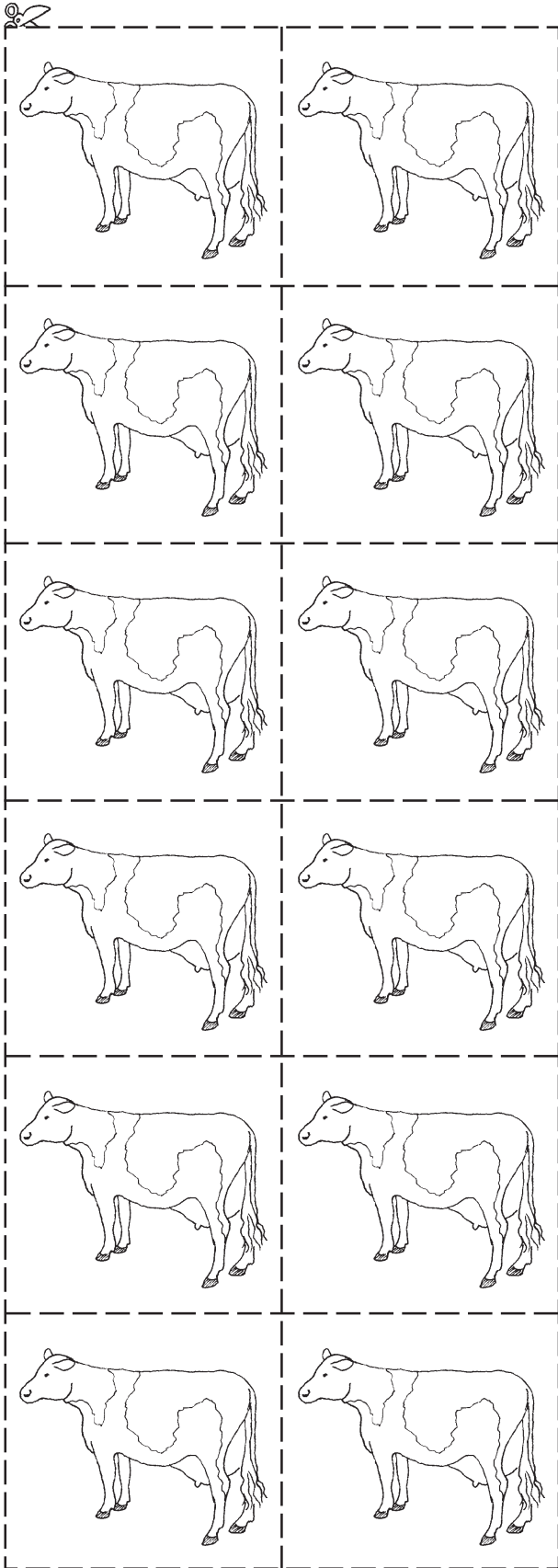
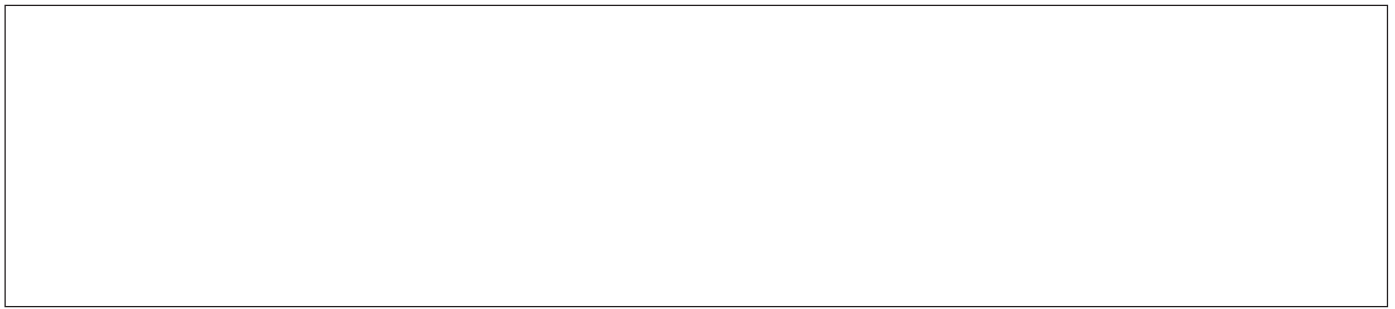

Teachers' note: pictures to use with pages 7 and 8.

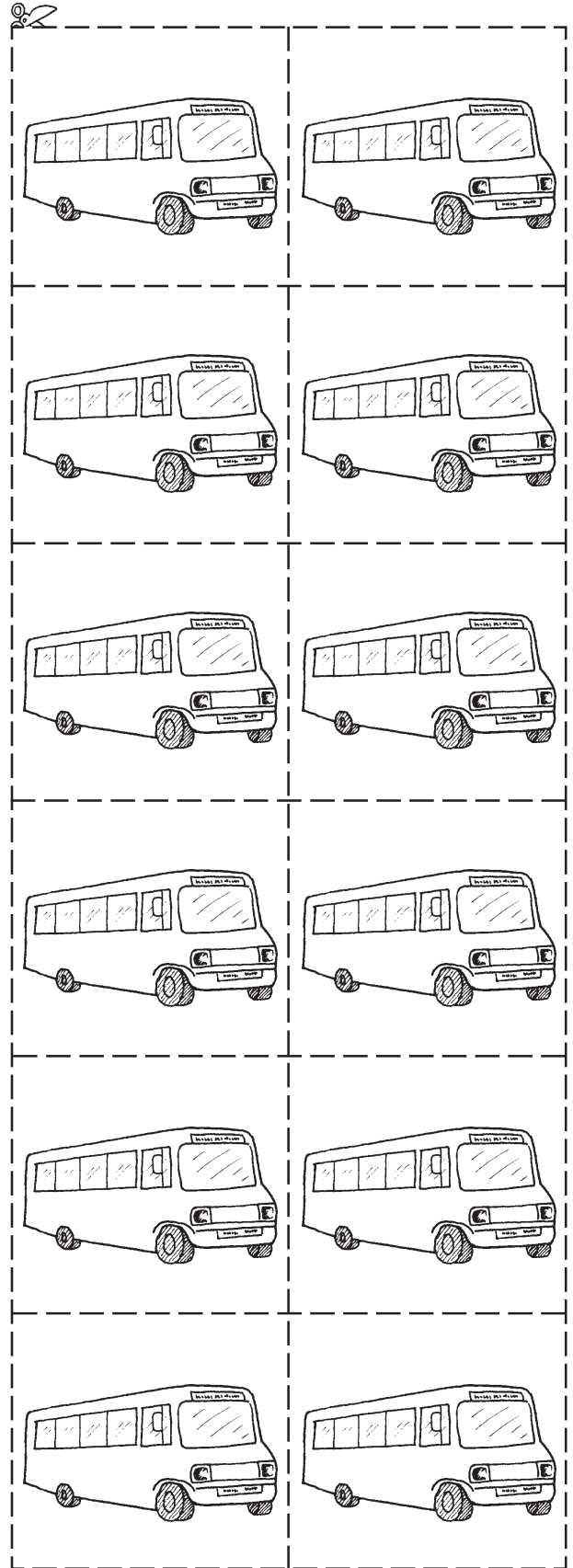
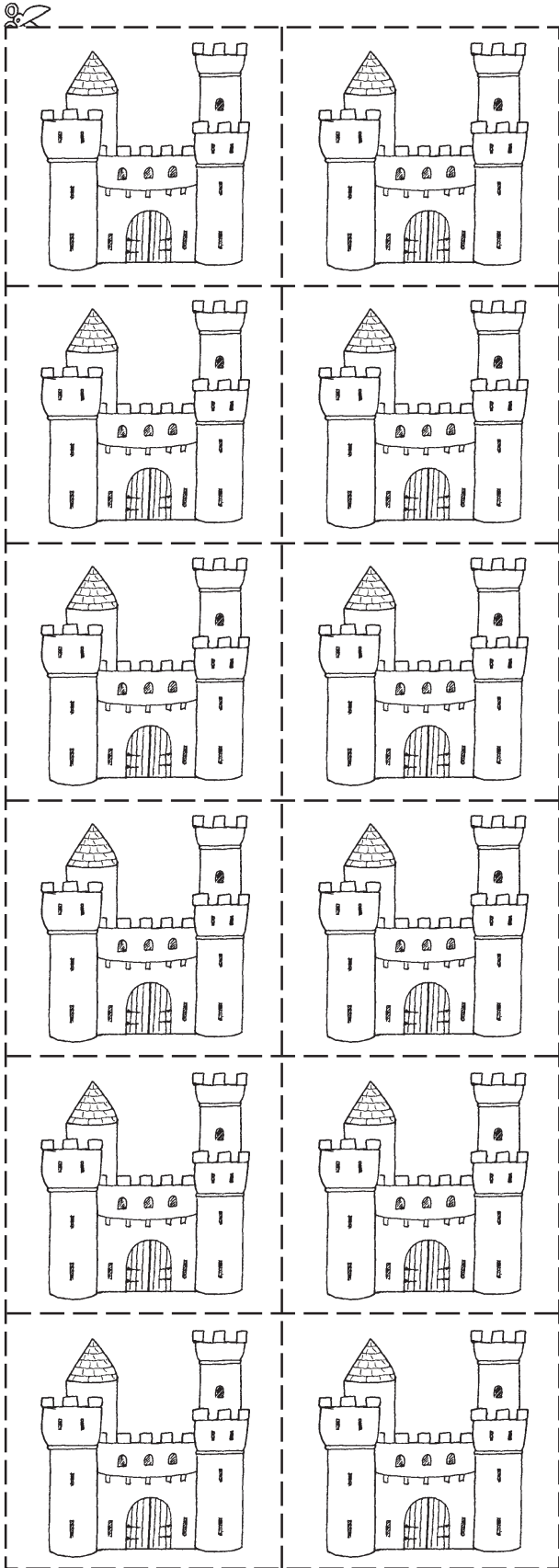

Teachers' note: pictures to use with pages 9 and 10.

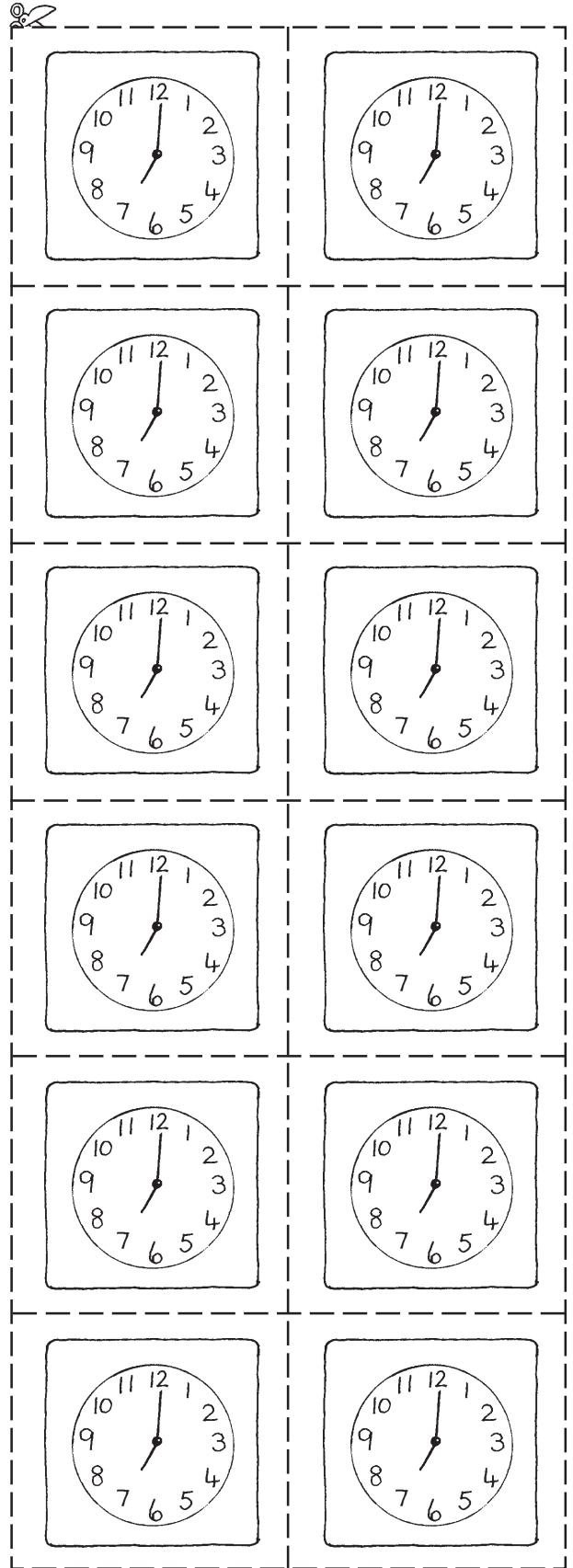
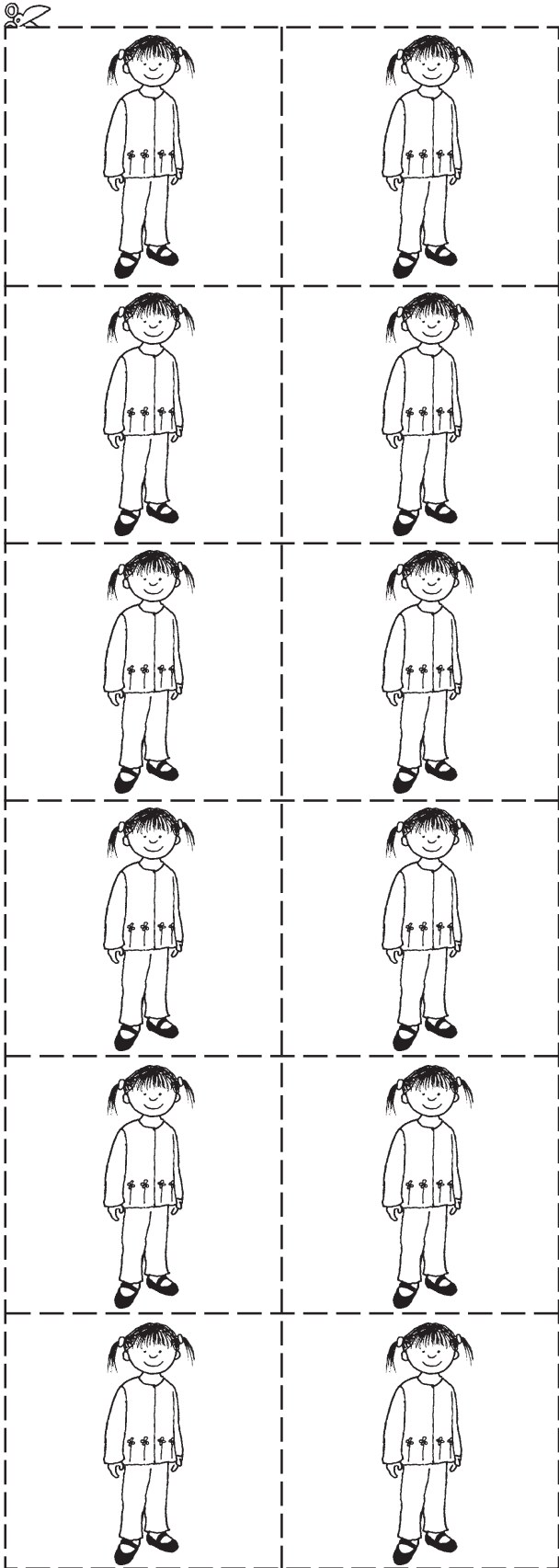
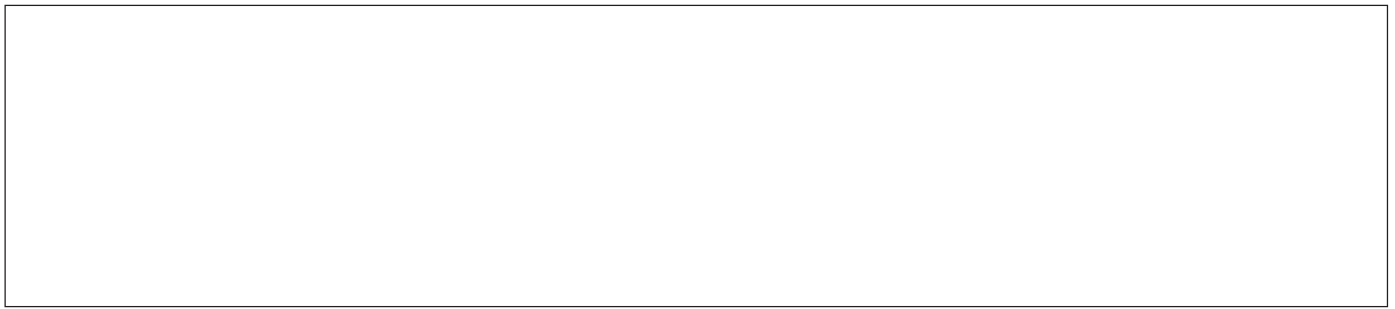

Teachers' note: pictures to use with pages 11 and 12.

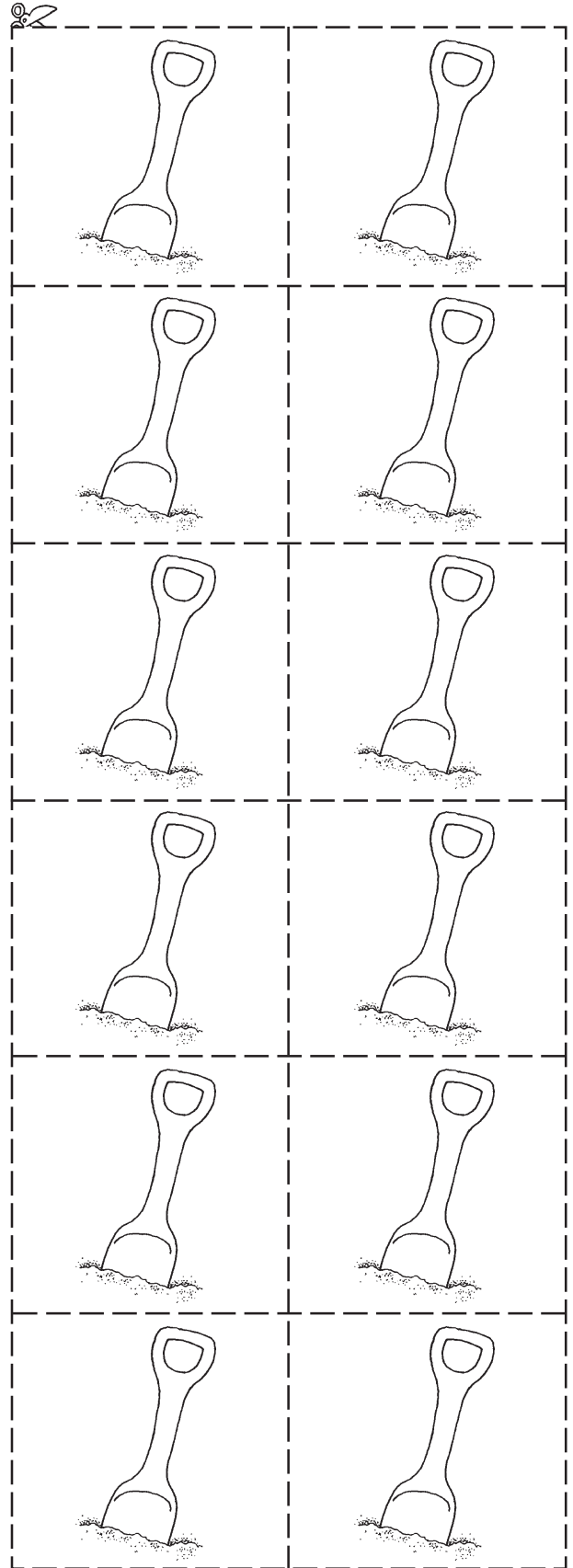
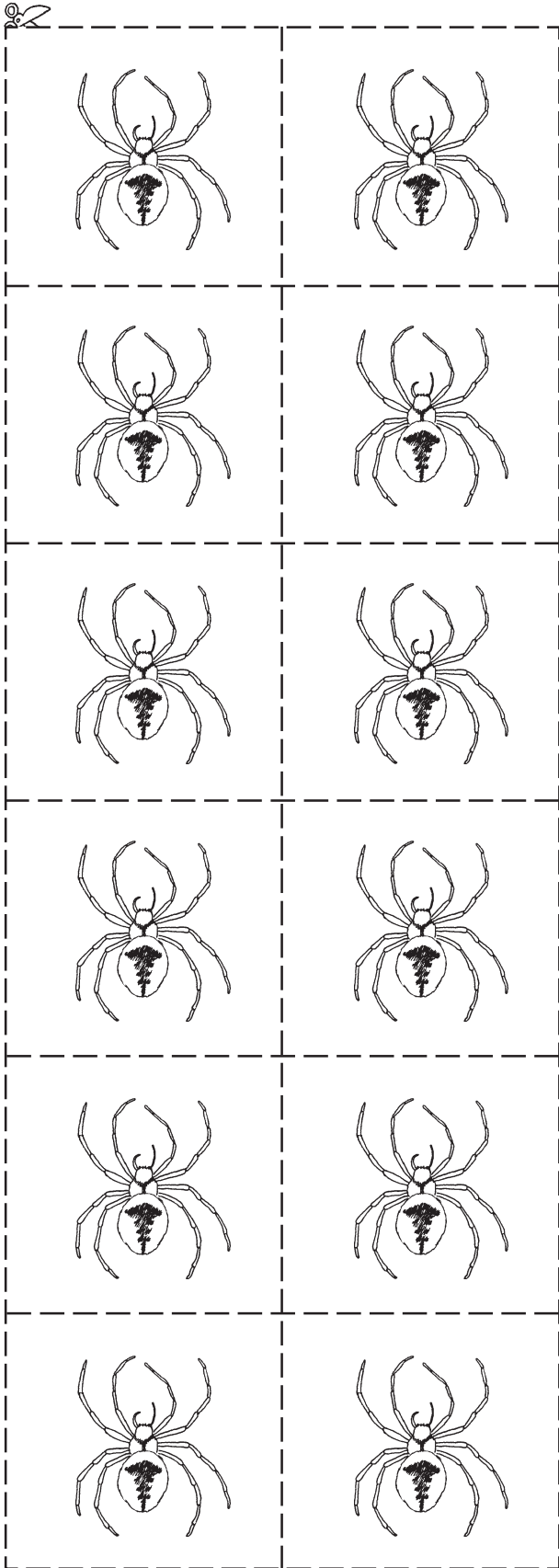

Teachers' note: pictures to use with pages 13 and 14.

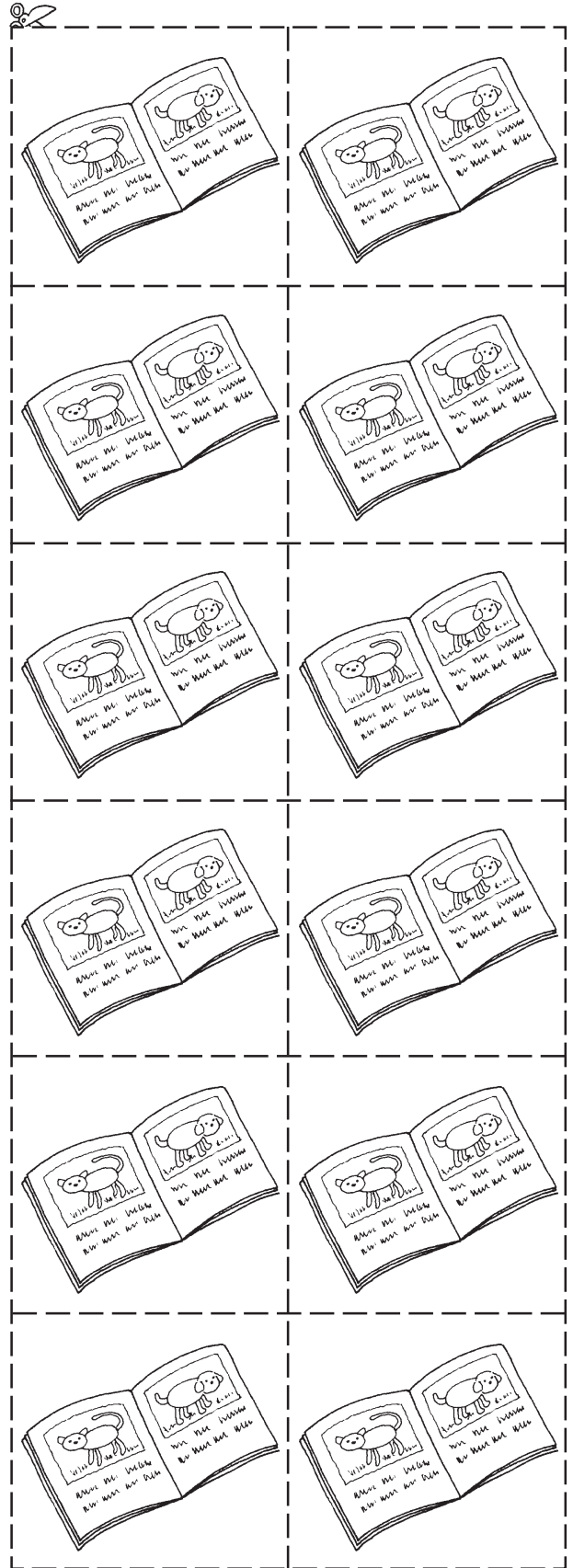
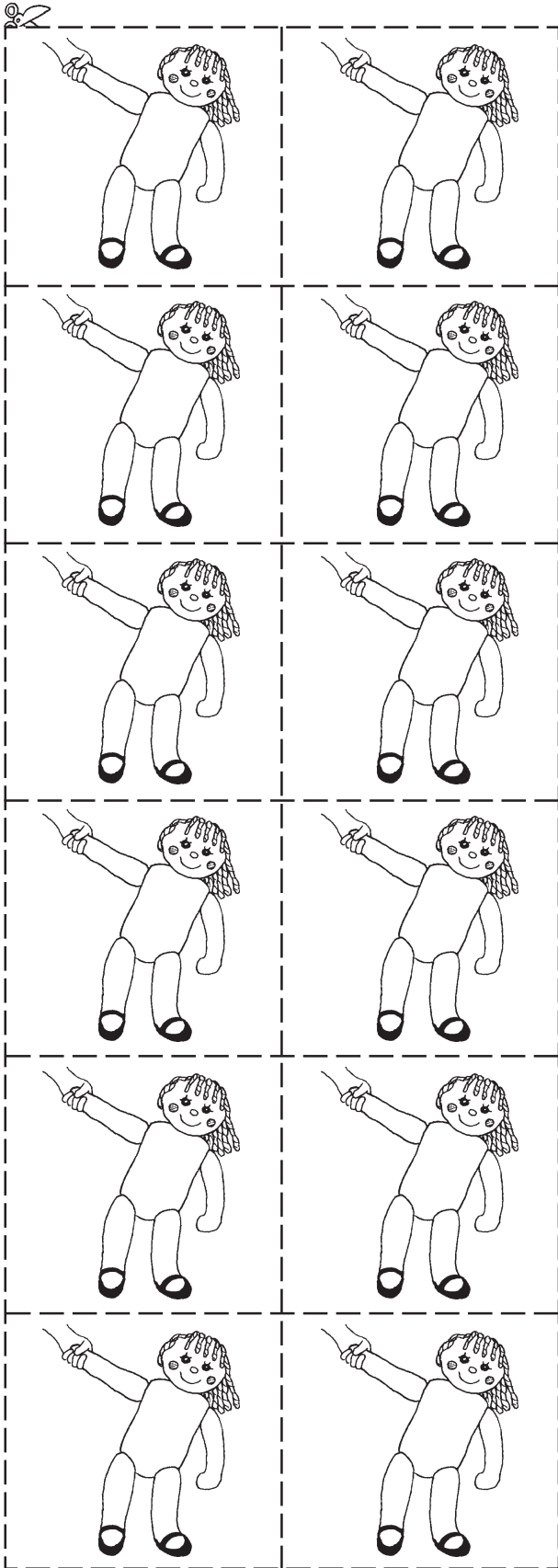
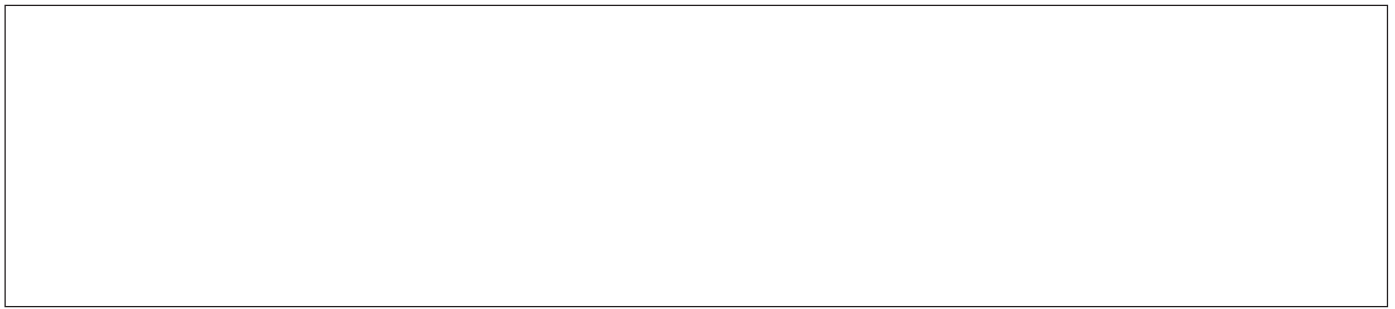

Teachers' note: pictures to use with pages 15 and 16.

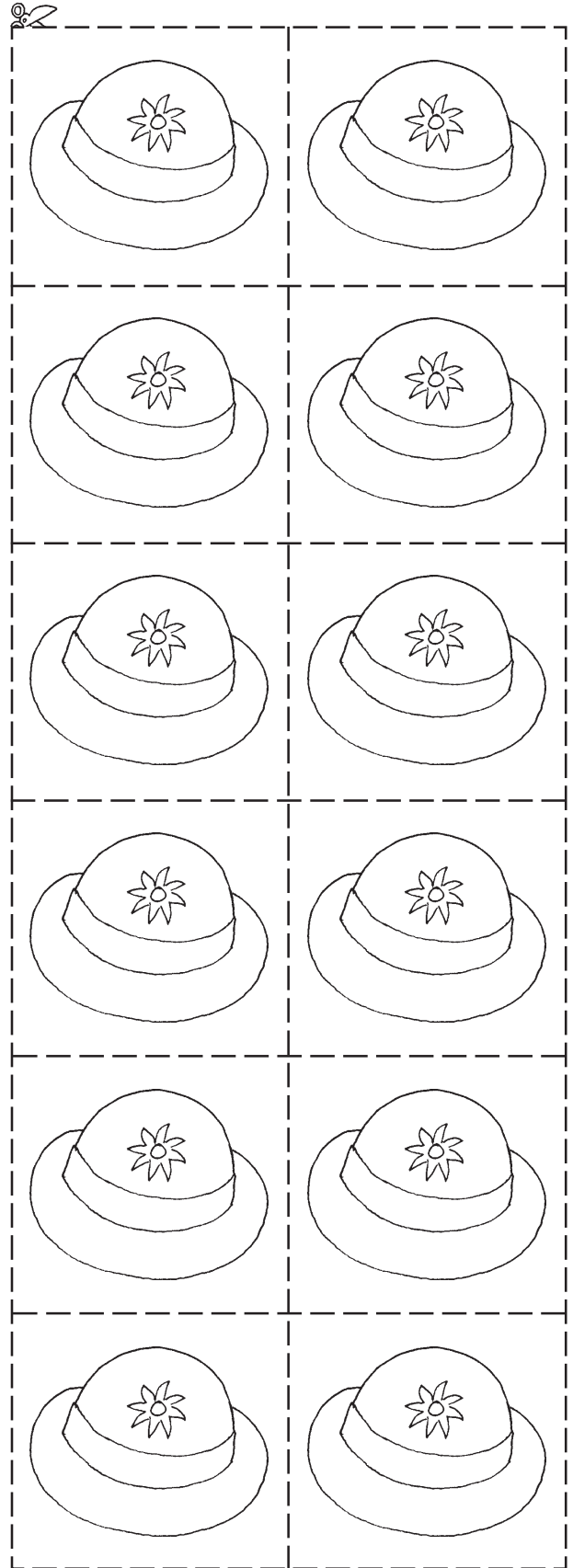
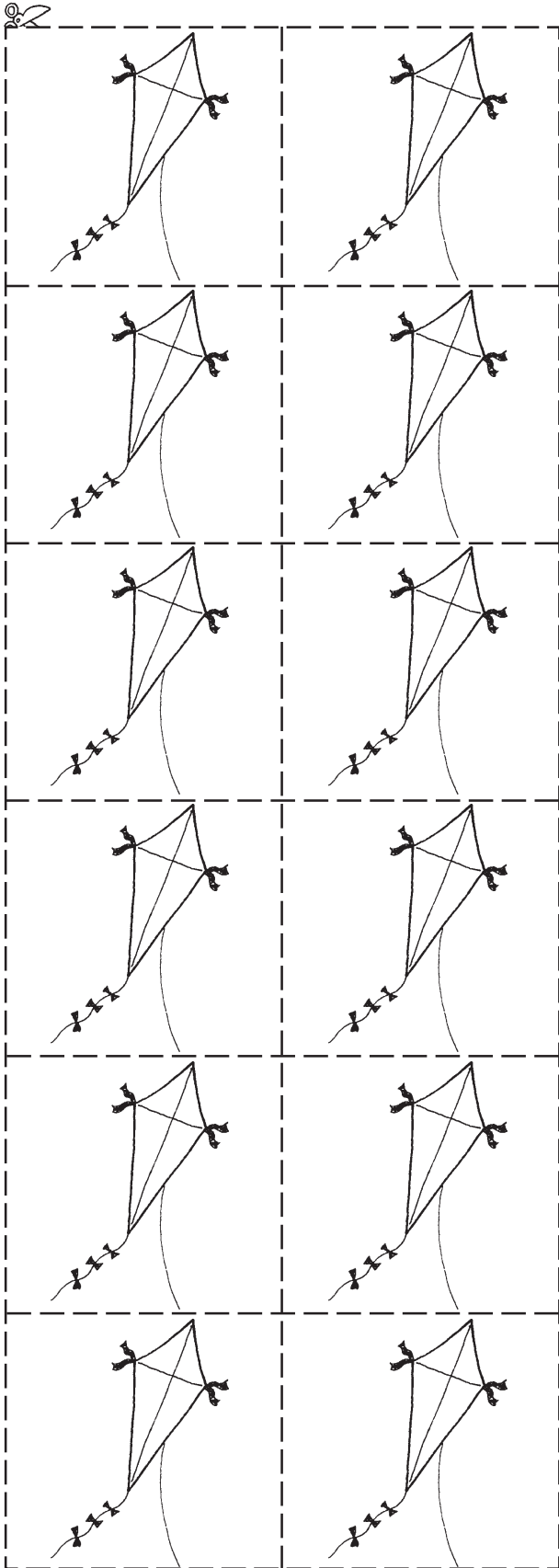
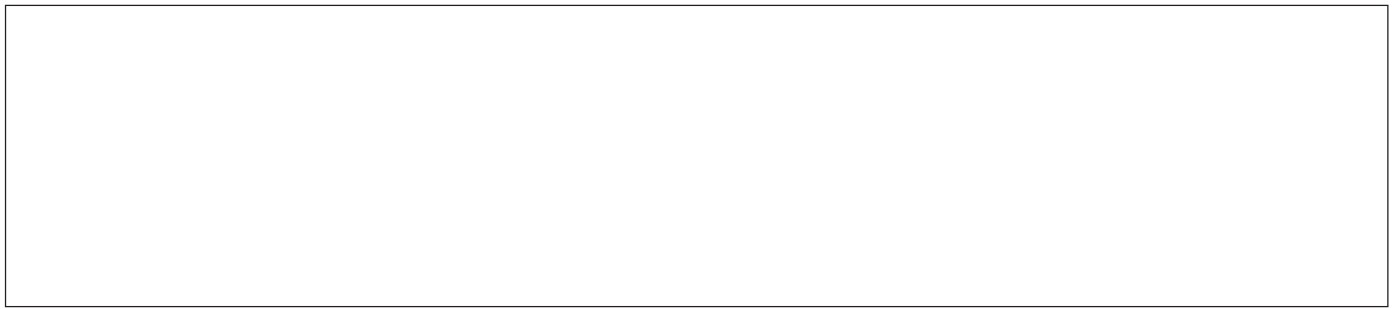

Teachers' note: pictures to use with pages 17 and 18.

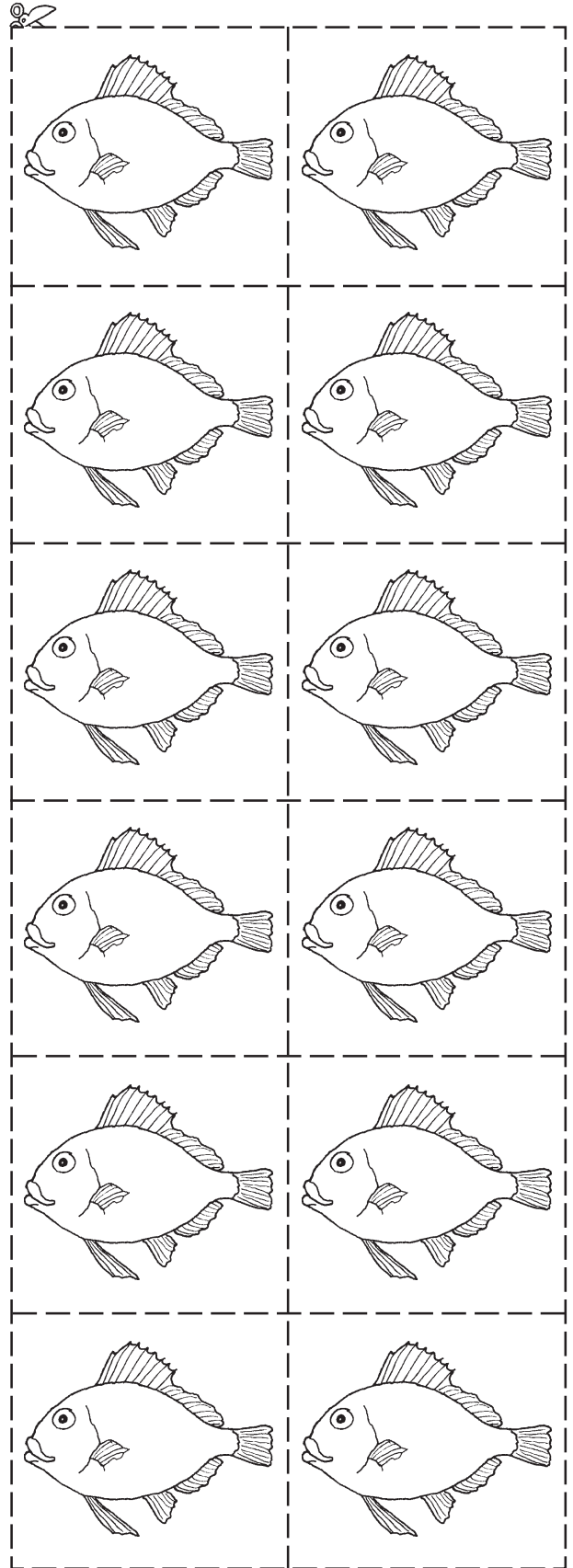
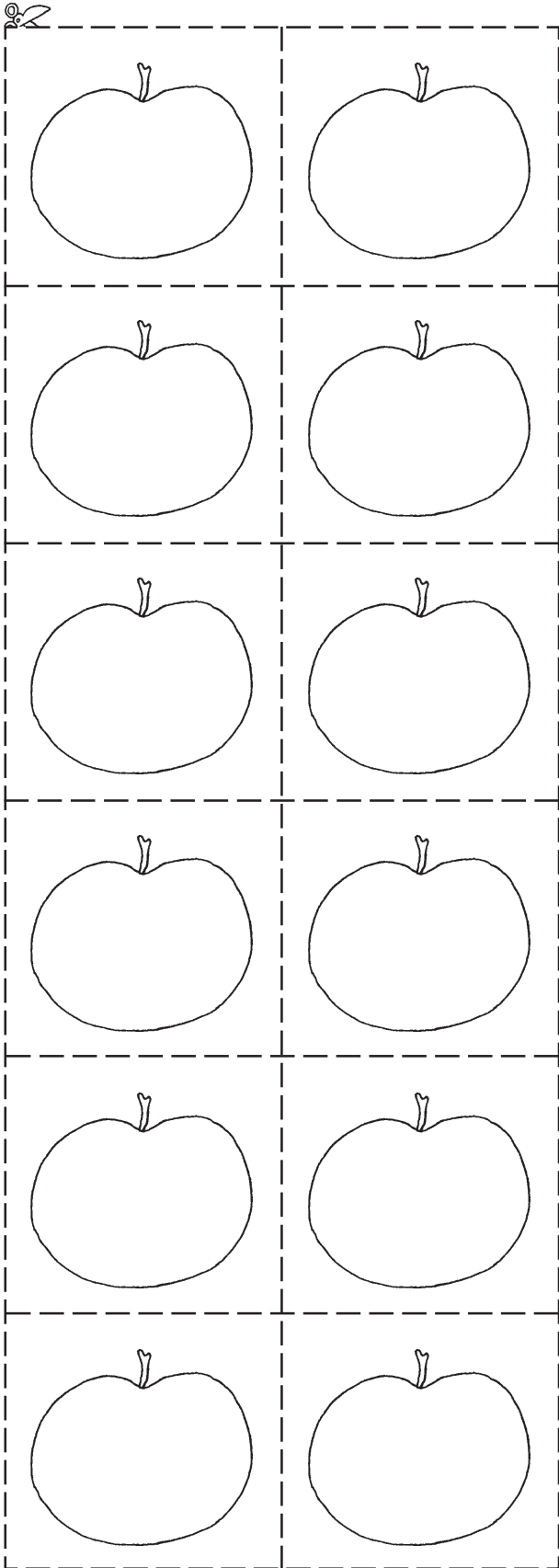
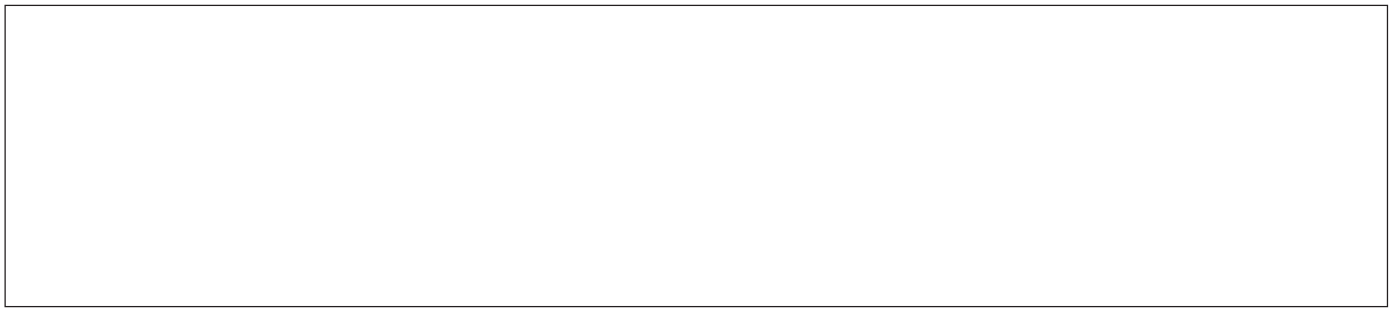

Teachers' note: pictures to use with pages 19 and 20.

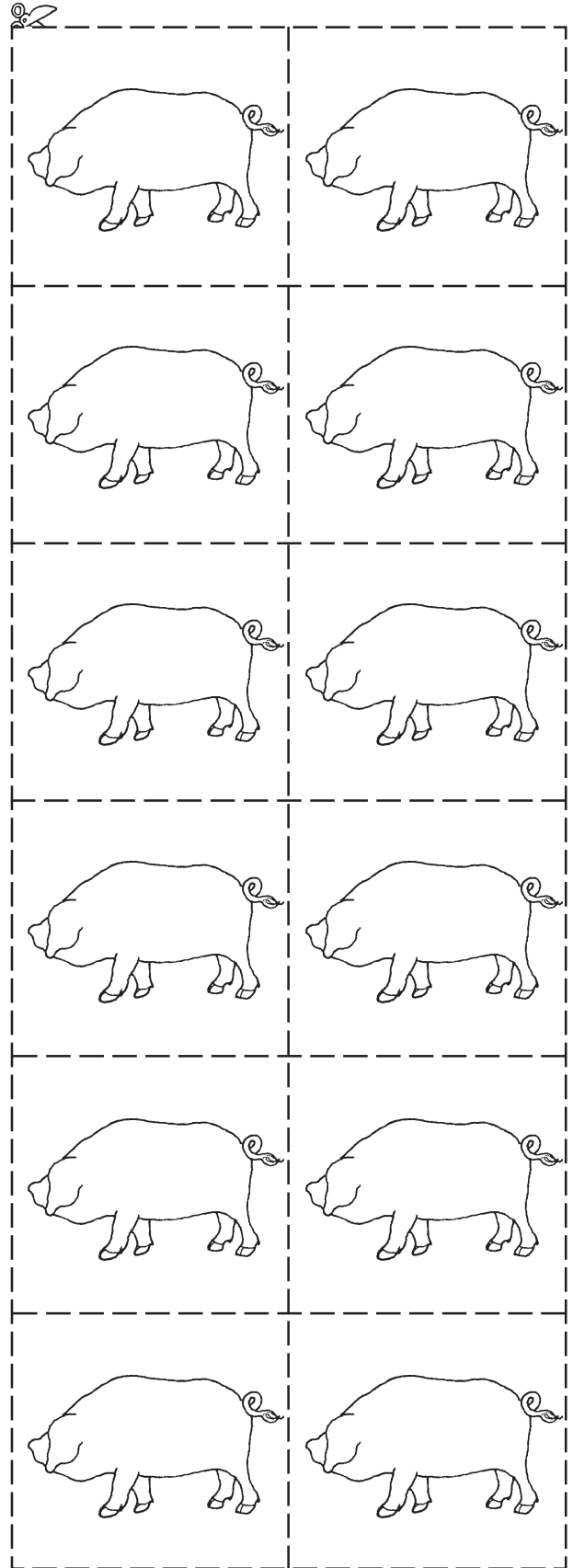
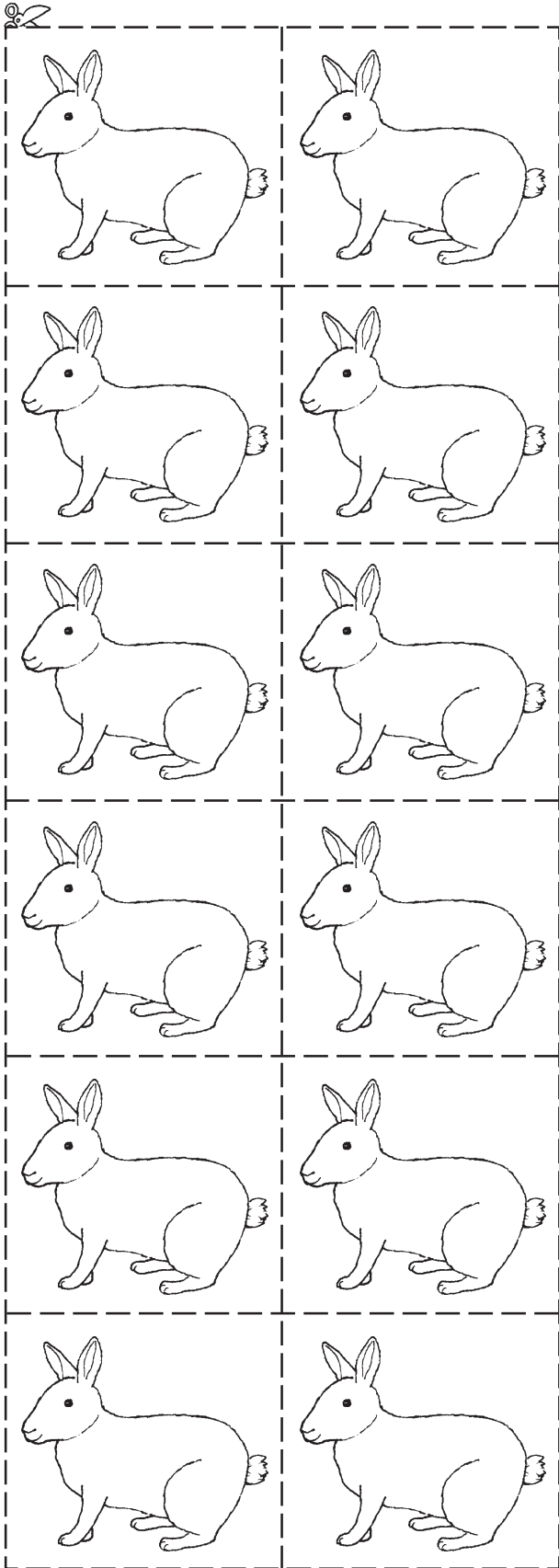

Teachers' note: pictures to use with pages 21 and 22.

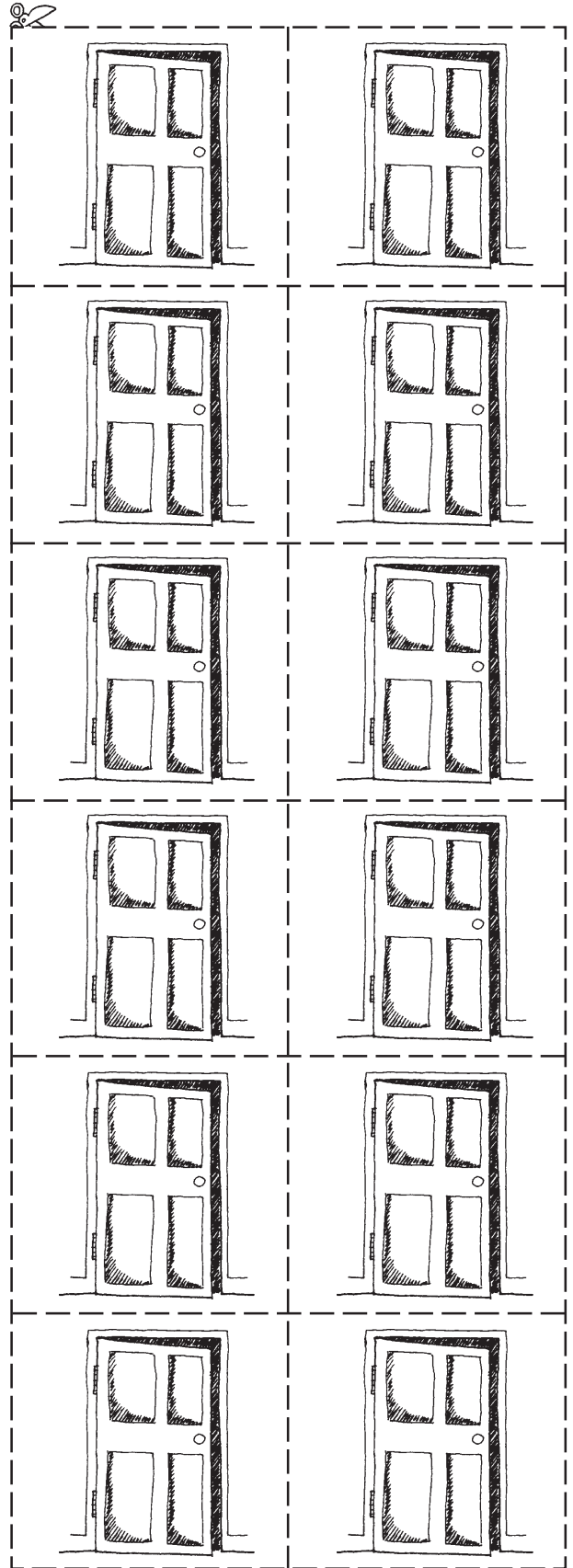
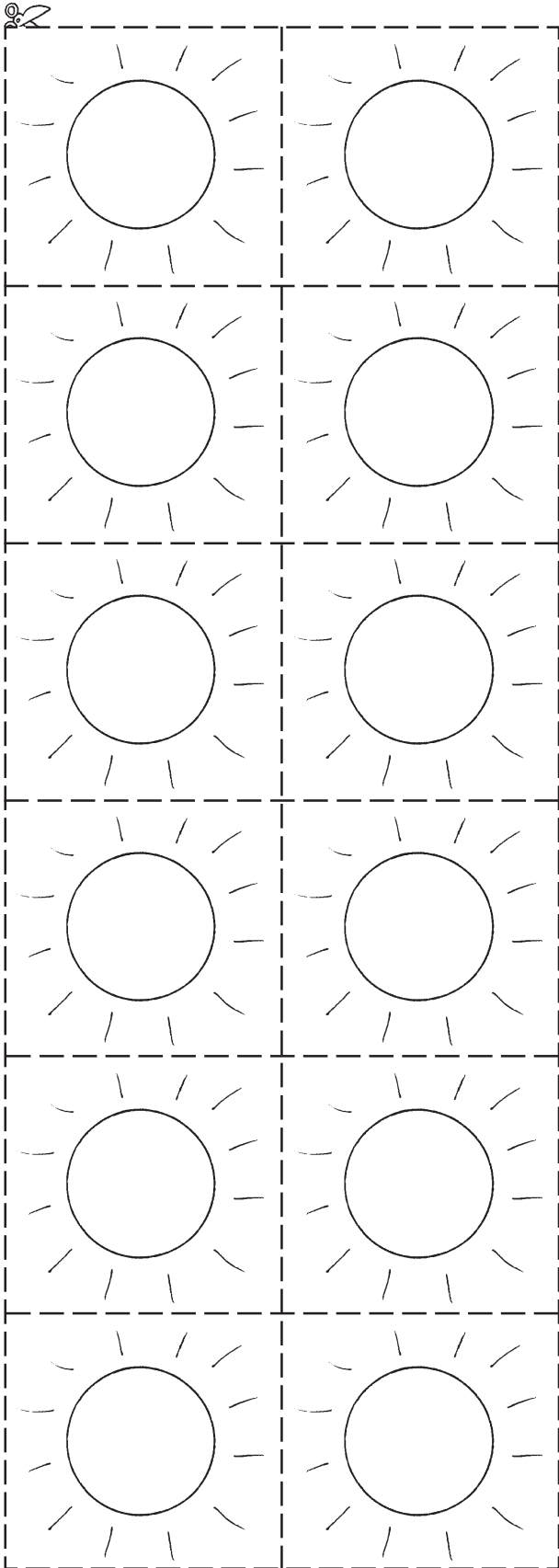
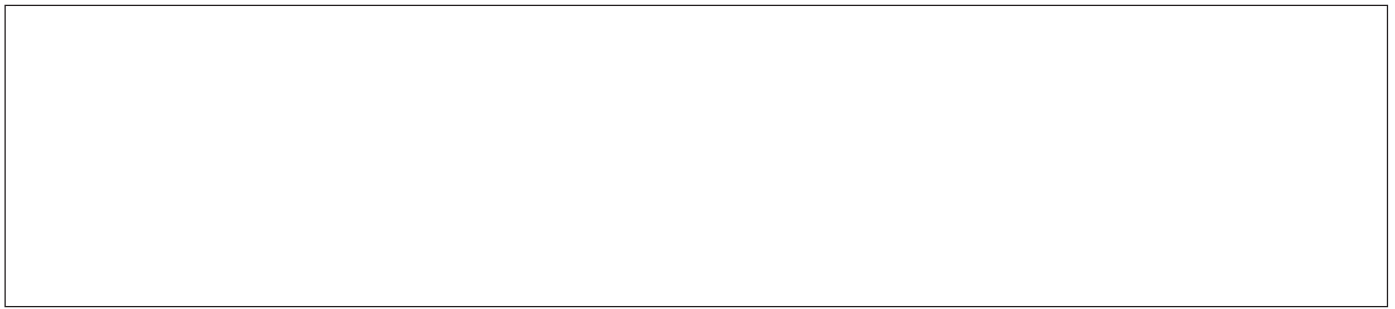

Teachers' note: pictures to use with pages 23 and 24.

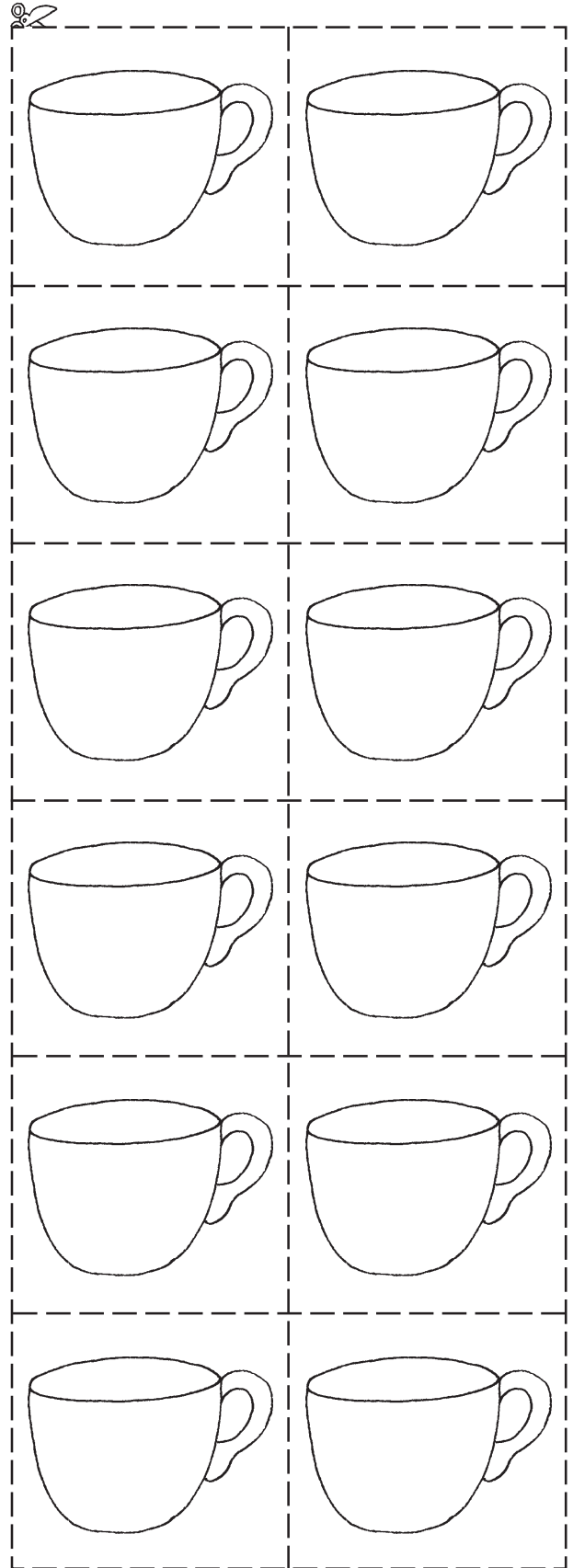
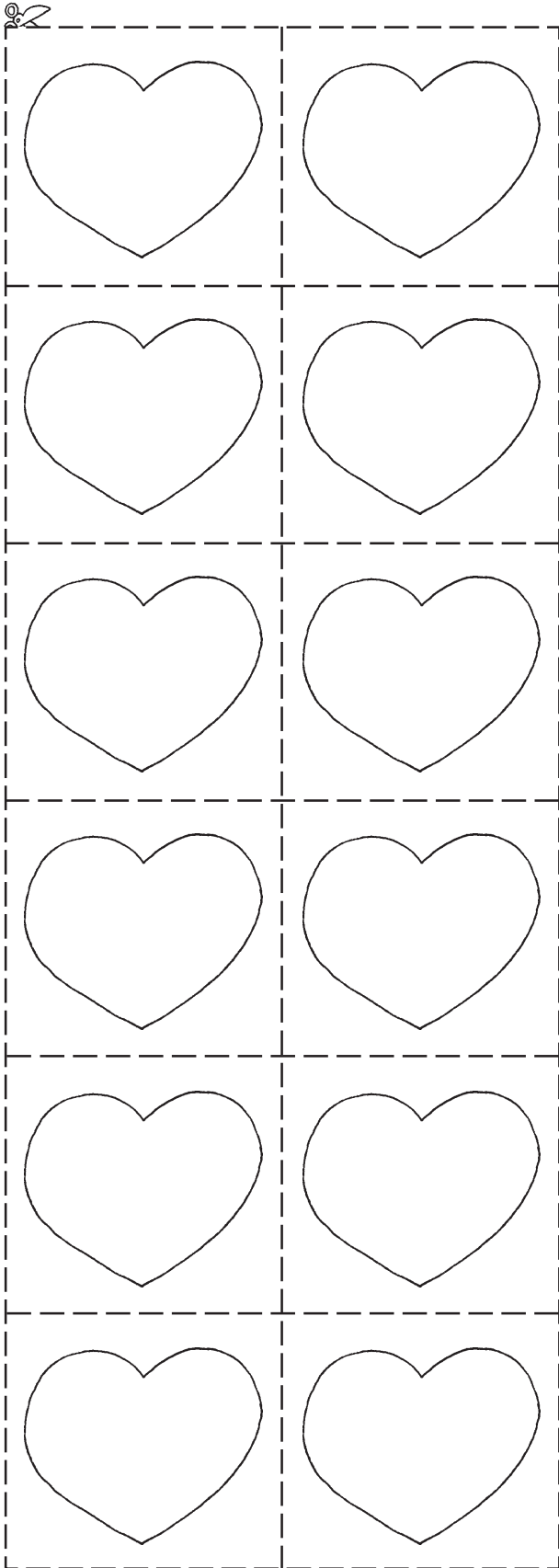

Teachers' note: pictures to use with pages 25 and 26.

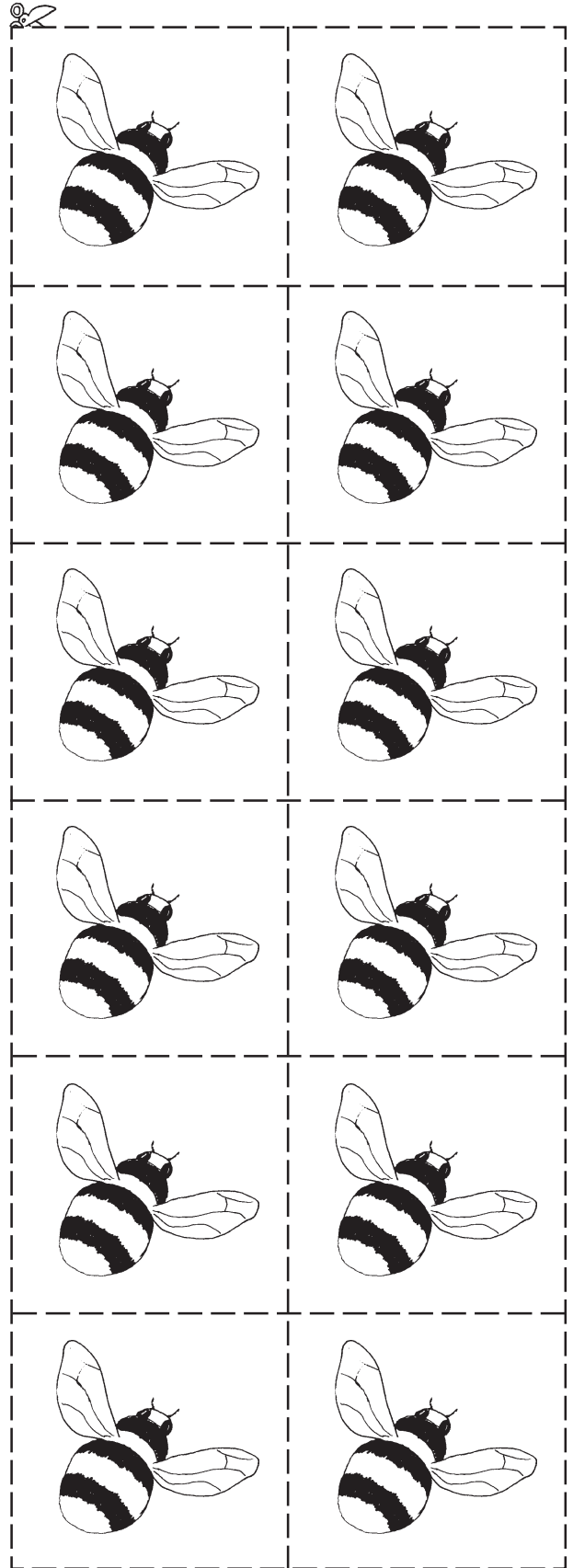
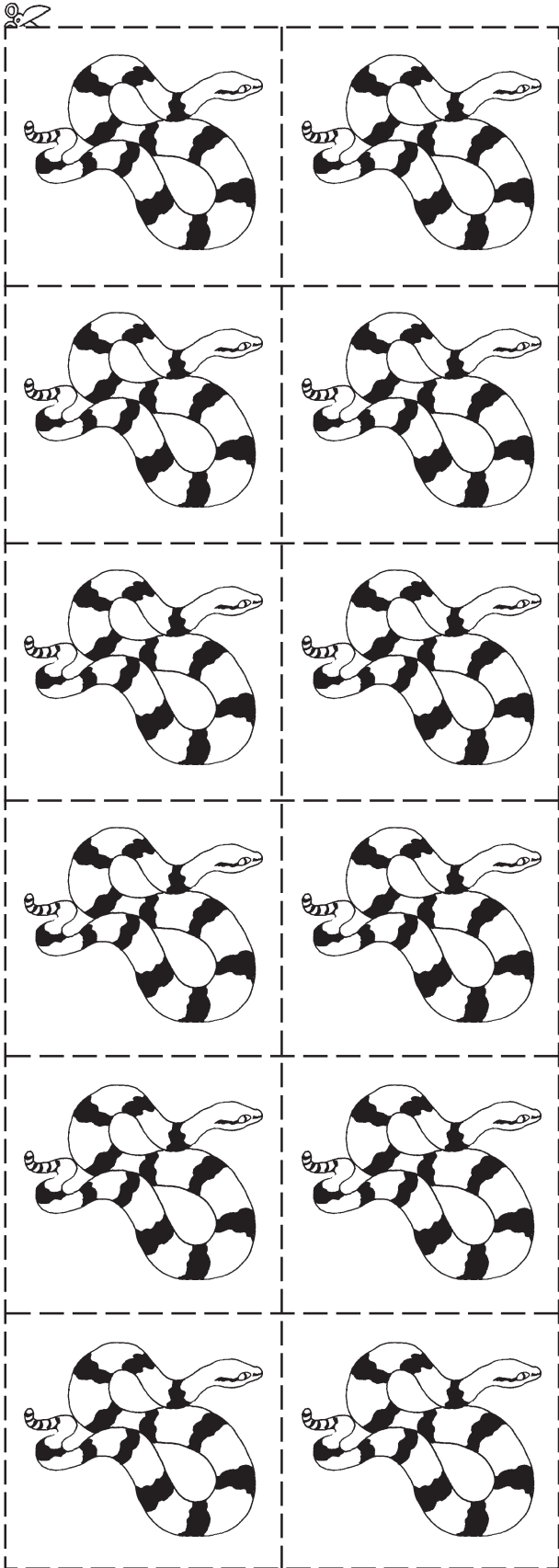
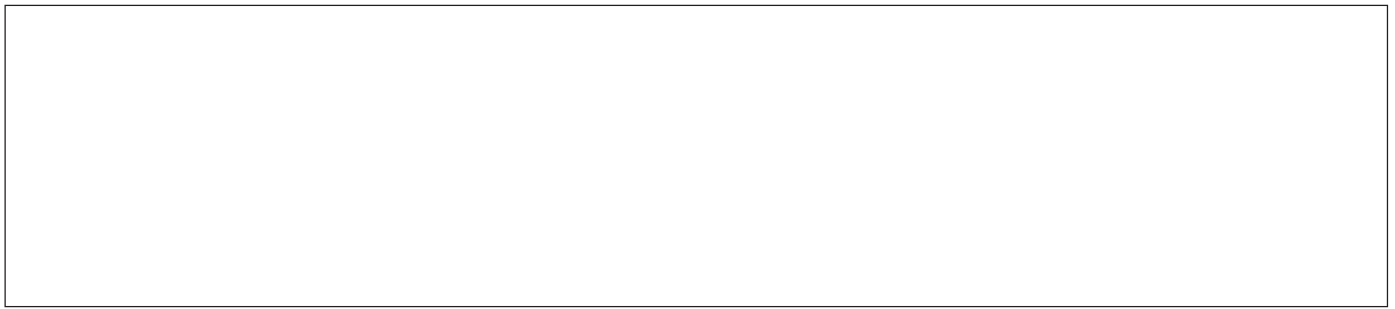

Teachers' note: pictures to use with pages 27 and 28.

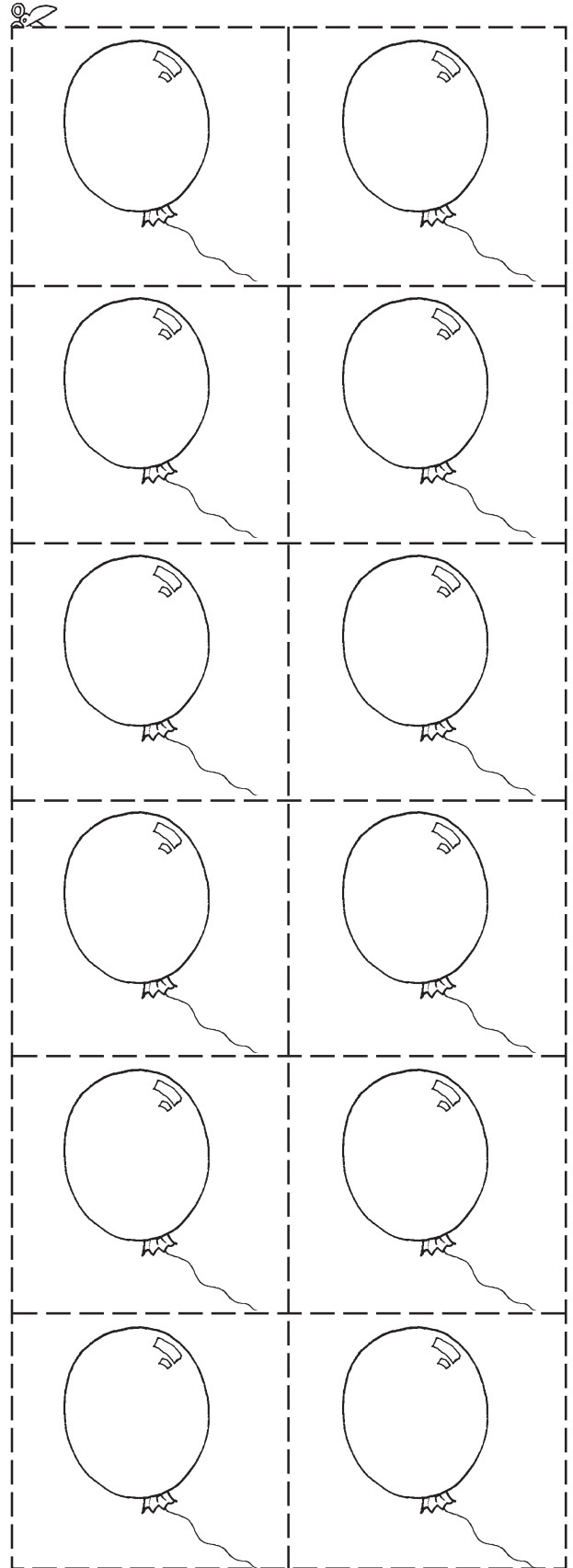
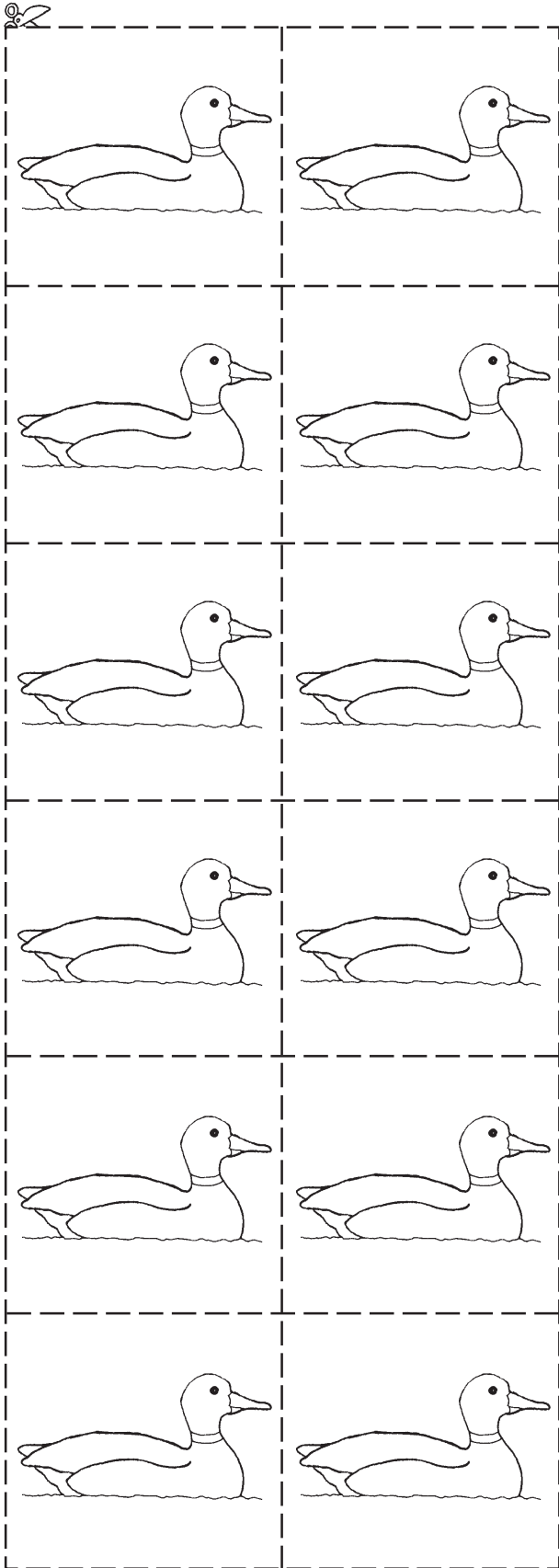

Teachers' note: pictures to use with pages 29 and 30.

Extension/Consolidation Activity

NOTES FOR TEACHERS

Page 58 is a blank sheet for you to complete as you wish. It enables you to create worksheets with objects different from the thirty used in the book, and to create more demanding worksheets. To make a worksheet, finish the *cut and stick* sentence at the top of the page and write numbers at the bottom.

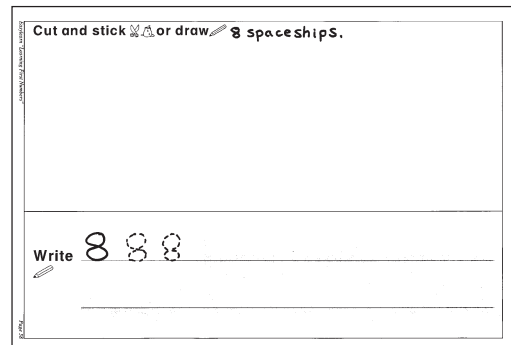
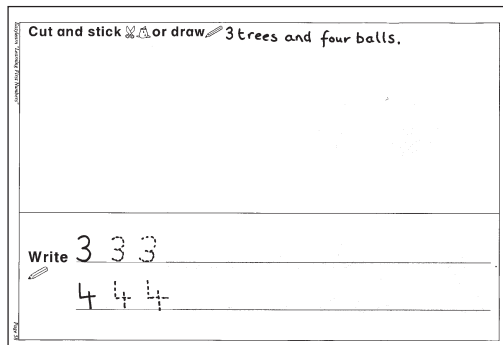

Example Worksheets

Small pictures and words for the 30 objects used in the book appear in the box below, should you wish to use these when creating worksheets.

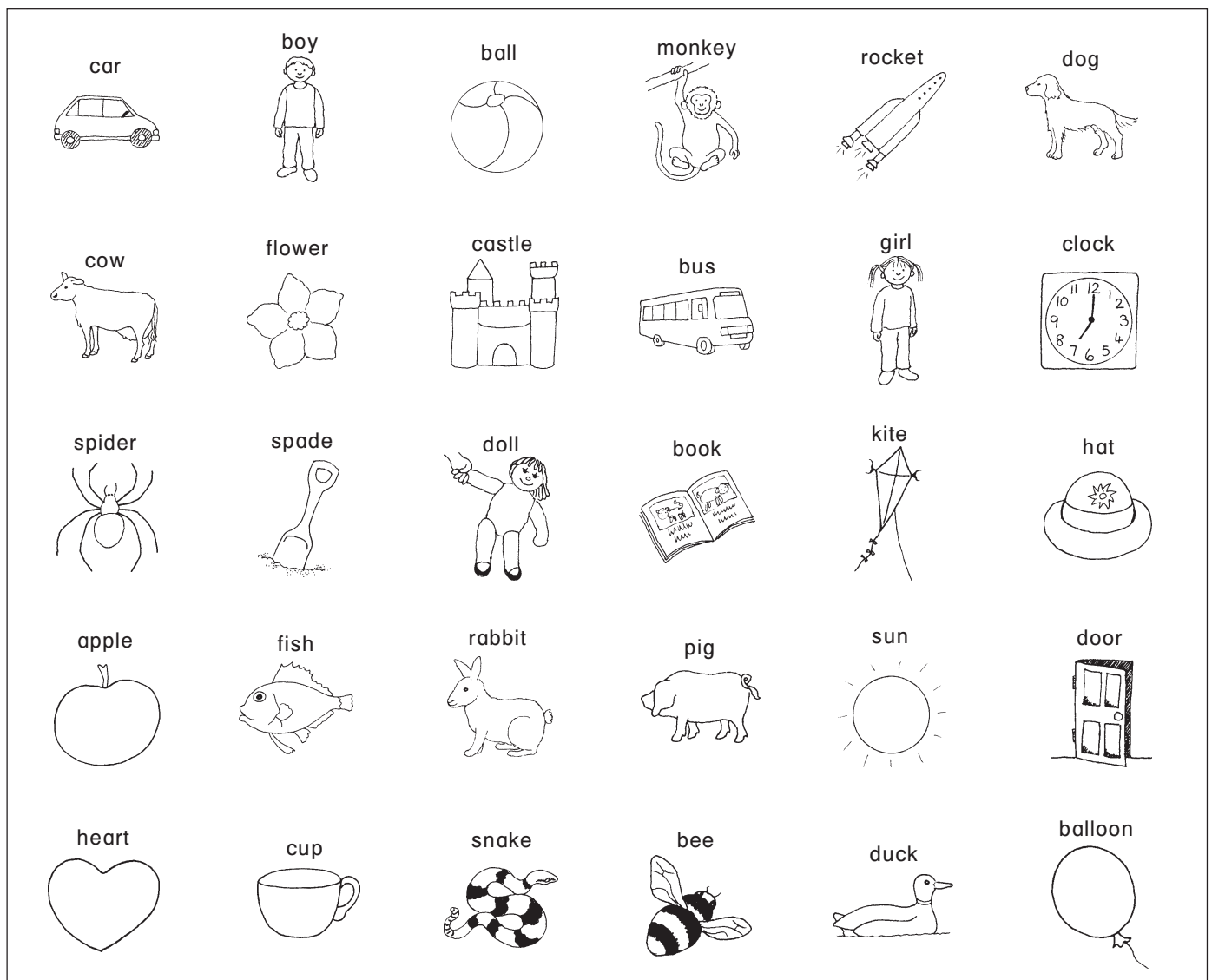

Cut and stick   **or draw** 

Write