

Blank space for name

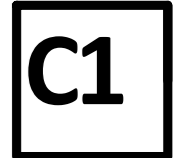
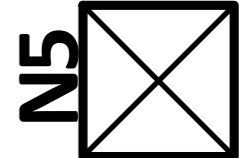

A major confectionary company wants you to redesign the packaging for their main chocolate product. The company want to investigate different types of packaging boxes rather than the standard square prism.

Using the following calculate required for volume of area x height. The formula has been rearranged for the height for each of the boxes.

The company want to still have the same volume but a different shape.

You must find the volume for the following shapes. (PICTORIAL VIEWS ARE NOT TO SCALE)

Height = 1020000mm³ / Area of Shape (π x r²)

Height = 1020000 /
Height =

Height = 1020000mm³ / Area of Shape(½ Breadth x Height)

Height = 1020000 /
Height =

Height = 1020000mm³ / Area of Shape (Breadth x Height)

Height = 1020000 /
Height =

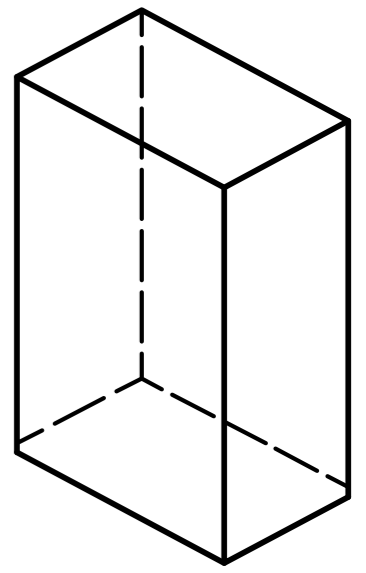
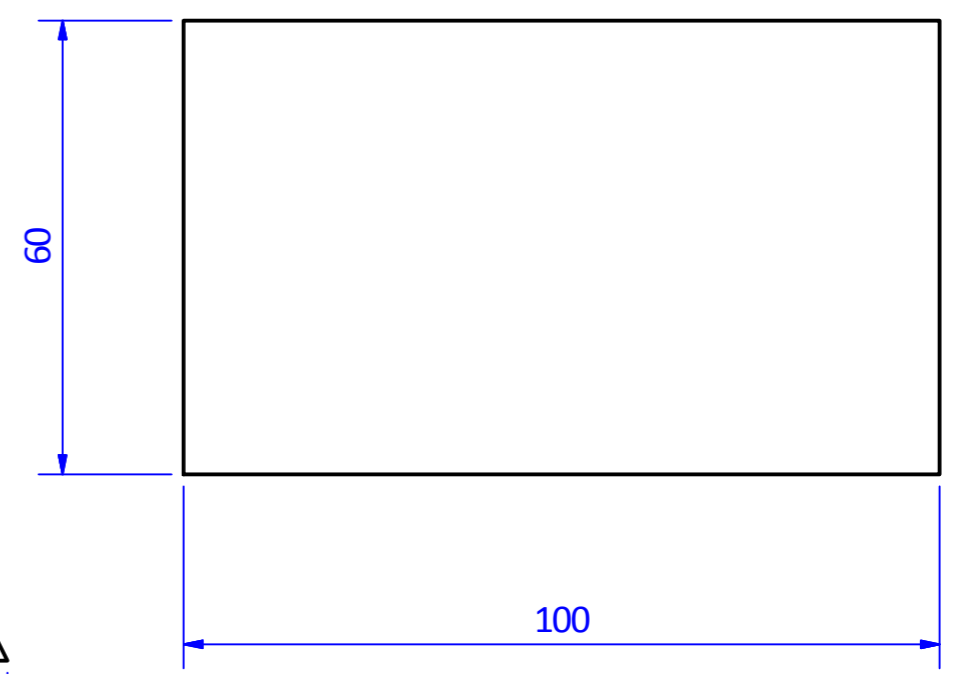
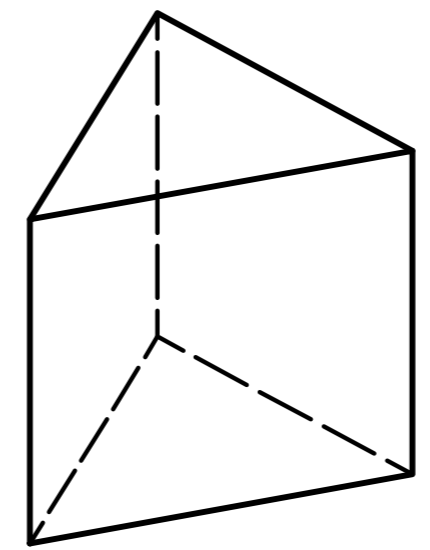
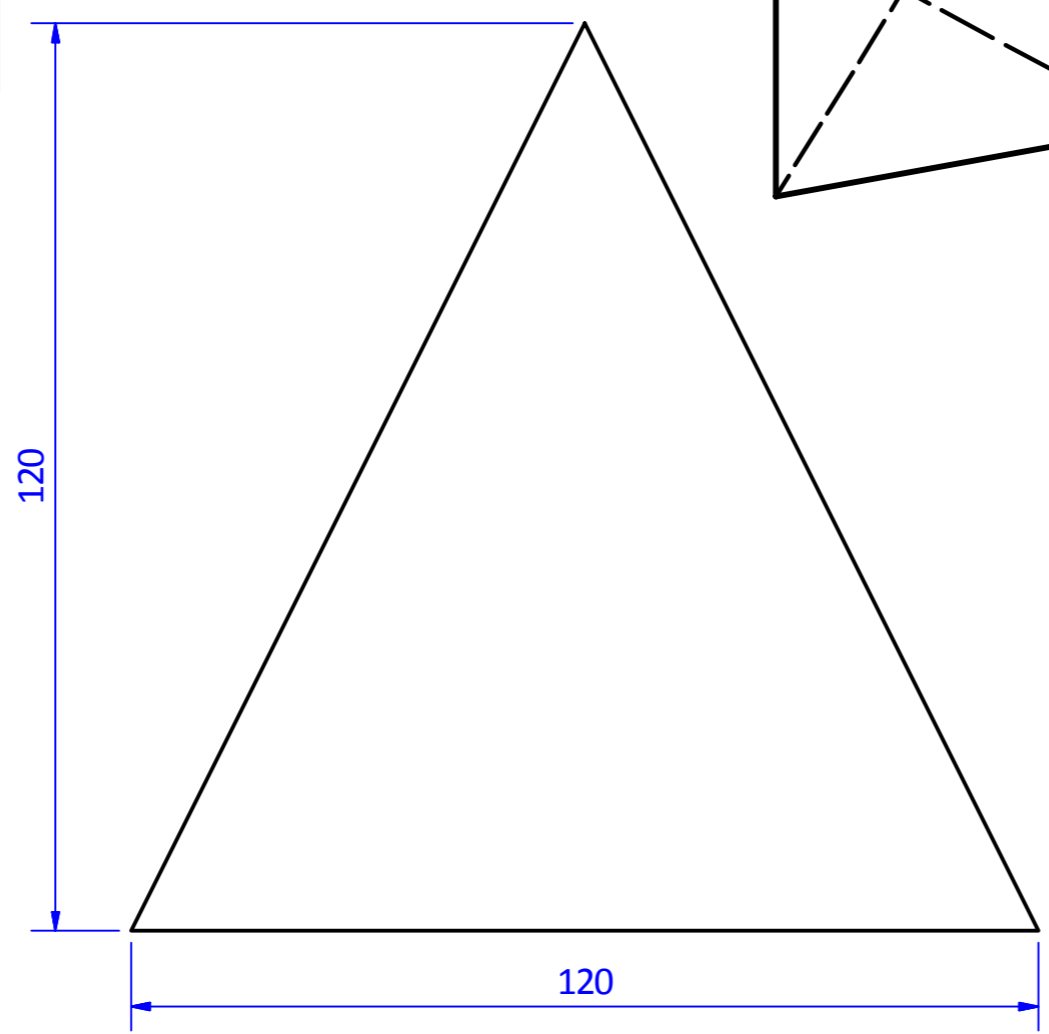
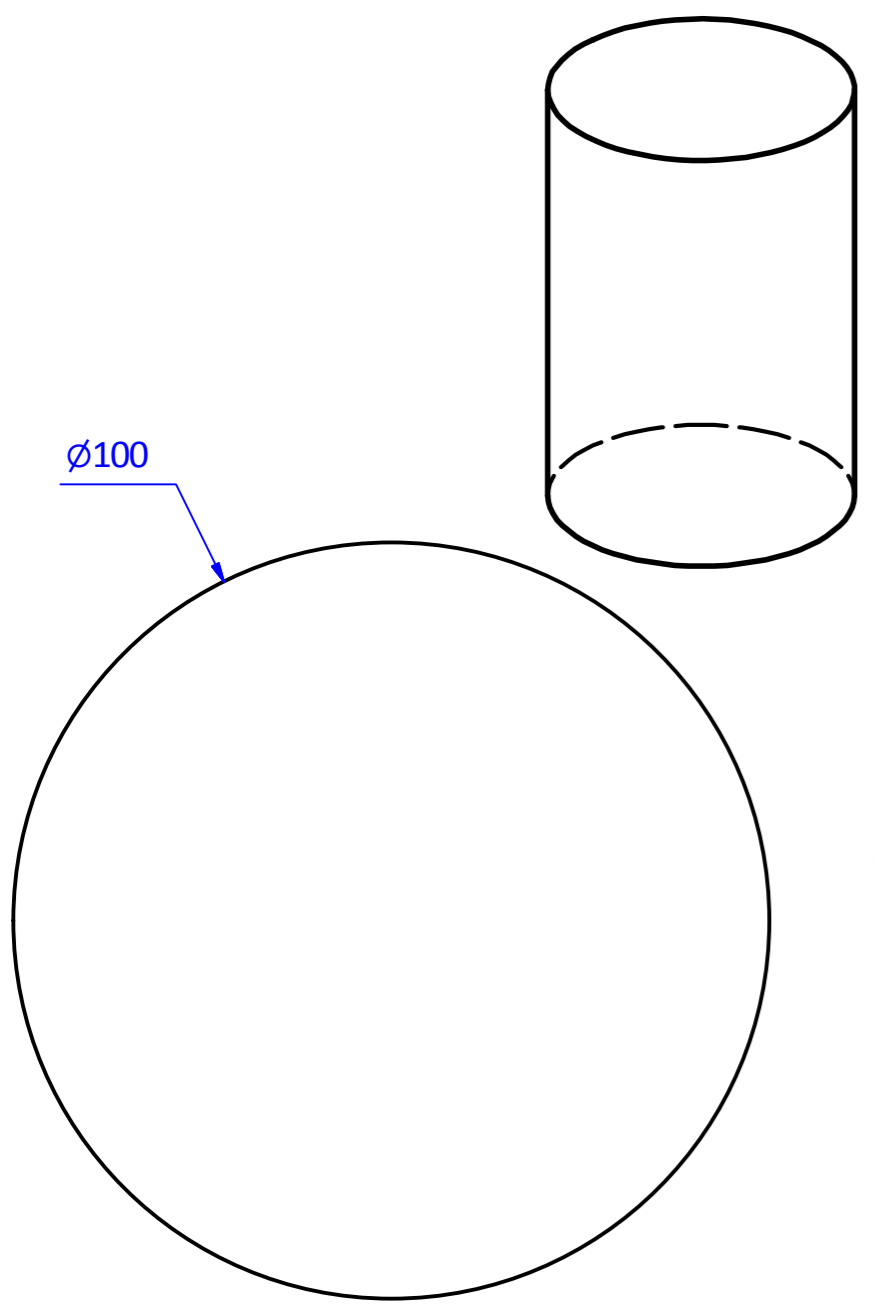

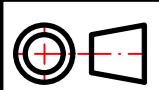

Empty box for name

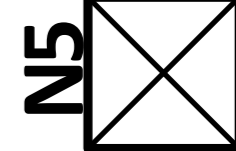

Use this worksheet for your THUMBNAIL ANALYSIS and MINDMAP the 5 W's

The Company wishes to create 3 new ranges for the festive Season. So to help you design this new range perform some primary research using the MINDMAP and the information below.

- (a) A general design to appeal to all customers.
- (b) A elegant design to appeal to a more upmarket customer.
- (c) A vibrant design to appeal to a more youthful customer.

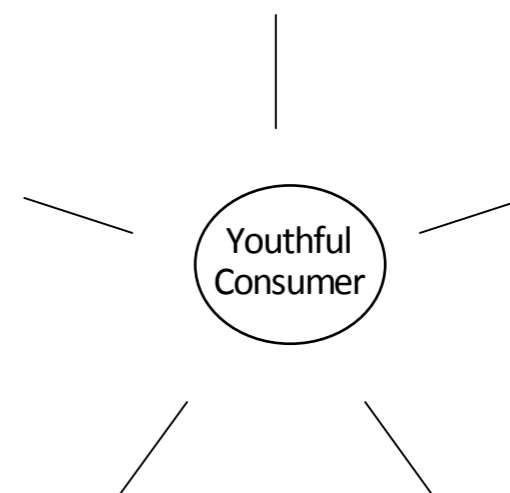
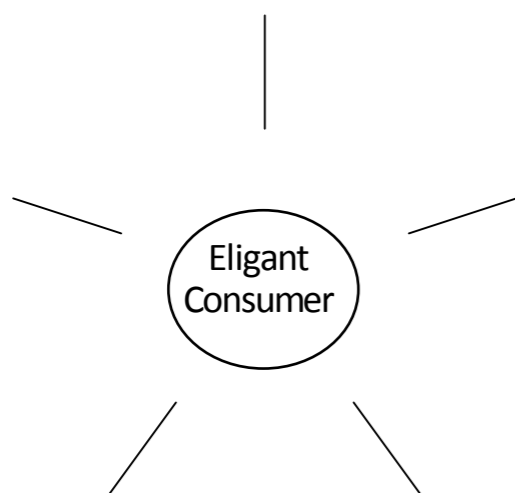
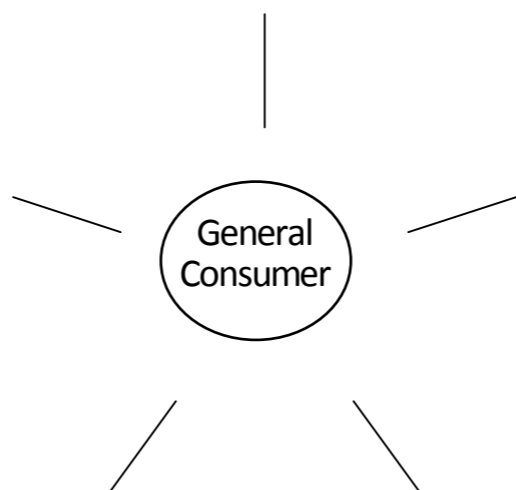

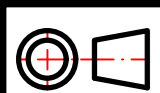

WHATS ON THE BOX

CHOCOLATE CHALLENGE

NAME

N5

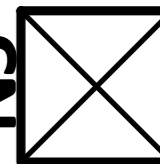

C3

1. Sketch a development for this shape full size

2. Now incorporate a viewing panel into each development so that you can see what is inside the box. Only use straight cuts.

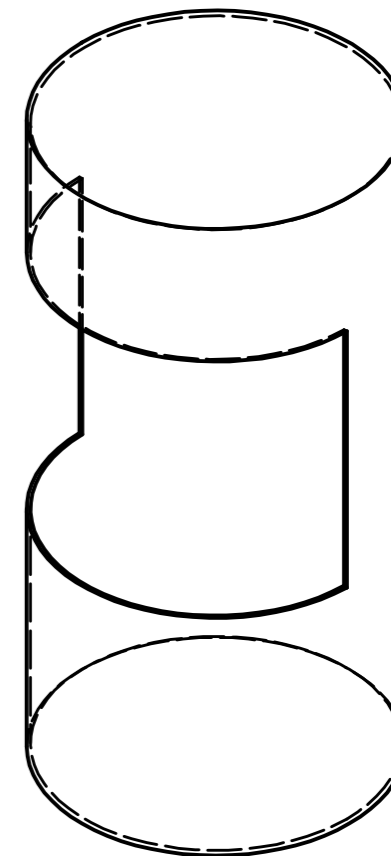

L

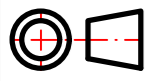

WHATS ON THE BOX

CHOCOLATE CHALLENGE

NAME

N5

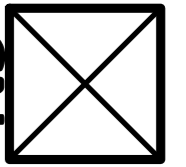

C4

Use this page to create your THUMBNAILS

- (a) A general design to appeal to all customers.
- (b) A elegant design to appeal to a more upmarket customer.
- (c) A vibrant design to appeal to a more youthful customer.

NB. YOU MAY FIND AN ANALYSIS USING A MIND MAP OR THE W's WILL AID YOUR DESIGN CREATION

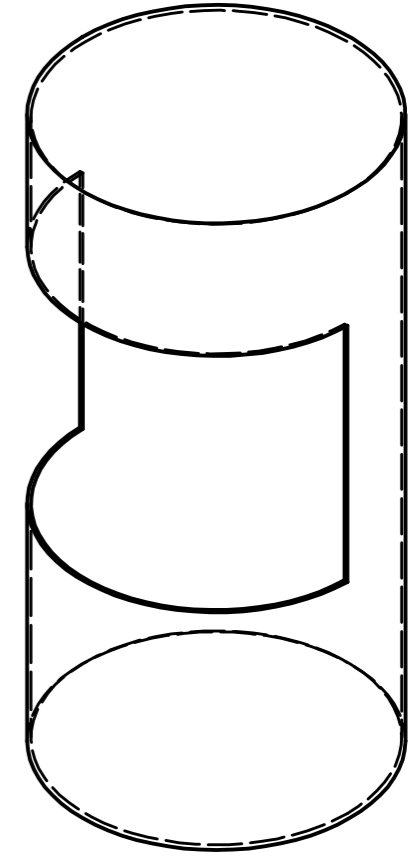

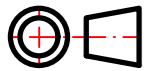

WHATS ON THE BOX

CHOCOLATE CHALLENGE

NAME

N5

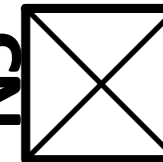

C5

1. Sketch a development for each shape full size
2. Now incorporate a viewing panel into each development so that you can see what is inside the box. Only use straight cuts.
3. Create a range of thumbnail designs for each of the development on the next worksheet.
 - (a) A general design to appeal to all customers.
 - (b) A elegant design to appeal to a more upmarket customer.
 - (c) A vibrant design to appeal to a more youthful customer.

NB. YOU MAY FIND AN ANALYSIS USING A MIND MAP OR THE W's WILL AID YOUR DESIGN CREATION

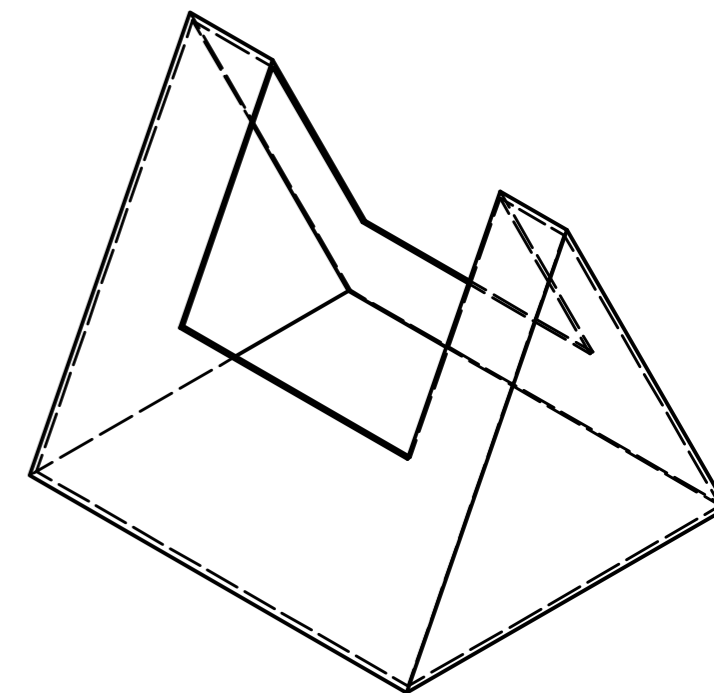

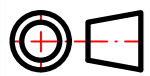

WHATS ON THE BOX

CHOCOLATE CHALLENGE

NAME

N5

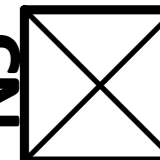

C6

Use this page to create your THUMBNAILS

- (a) A general design to appeal to all customers.
- (b) A elegant design to appeal to a more upmarket customer.
- (c) A vibrant design to appeal to a more youthful customer.

NB. YOU MAY FIND AN ANALYSIS USING A MIND MAP OR THE W's WILL AID YOUR DESIGN CREATION

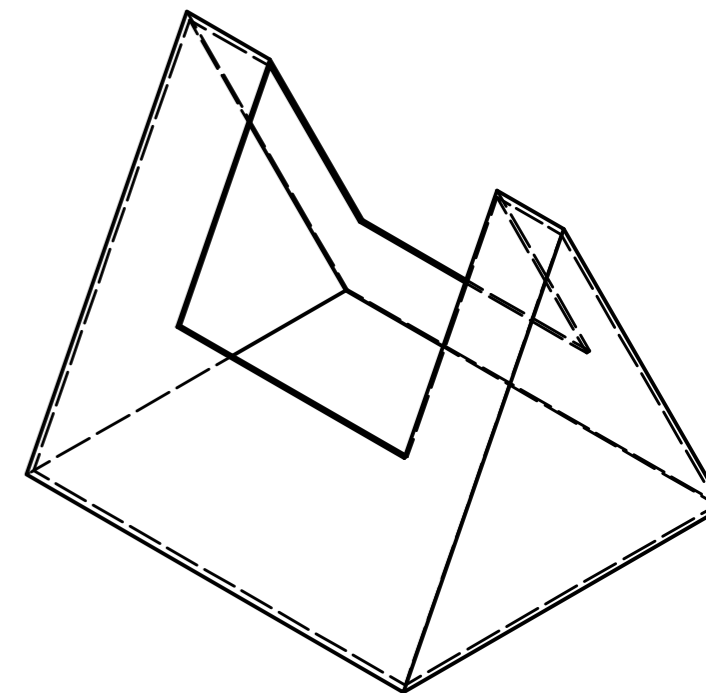

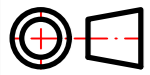

WHATS ON THE BOX

CHOCOLATE CHALLENGE

NAME

N5

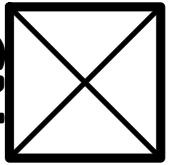

C7

1. Sketch a development for this shape full size
2. Now incorporate a viewing panel into each development so that you can see what is inside the box. Only use straight cuts.

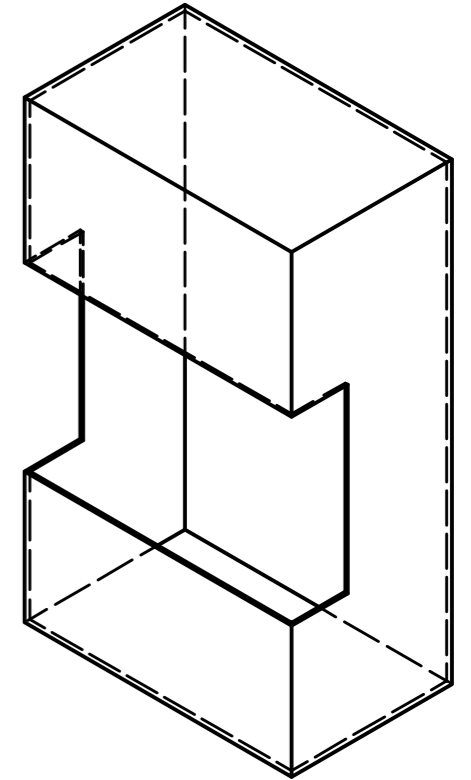

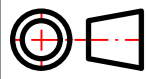

WHATS ON THE BOX

CHOCOLATE CHALLENGE

NAME

N5

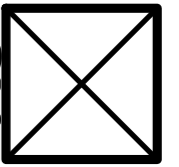

C8

Use this page to create your THUMBNAILS

- (a) A general design to appeal to all customers.
- (b) A elegant design to appeal to a more upmarket customer.
- (c) A vibrant design to appeal to a more youthful customer.

NB. YOU MAY FIND AN ANALYSIS USING A MIND MAP OR THE W's WILL AID YOUR DESIGN CREATION

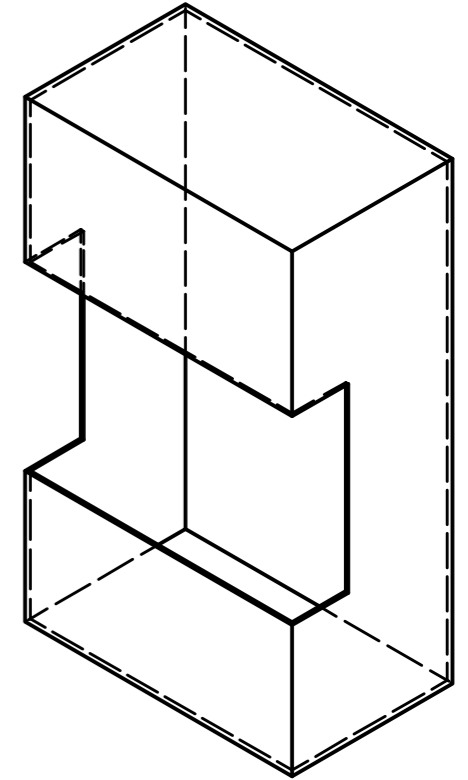

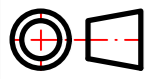

WHATS IN THE BOX

CHOCOLATE CHALLENGE

NAME



CREATE AN ISOMETRIC OF YOUR SKETCHED DEVELOPMENTS WITH THE ADDED CUT AND ONE OF THE SELECTED DESIGNS.

ONCE THIS IS COMPLETE CHOOSE ONE OF THE DESIGNS TO CREATE A DEVELOPMENT USING CARD AND DTP TO CREATE THE DECAL OF THE BOX.

