

FOR OFFICIAL USE

--	--	--	--	--	--

Section B Total Marks

--

X012/11/02

NATIONAL THURSDAY, 28 MAY
QUALIFICATIONS 9.00 AM – 11.00 AM
2015

CHEMISTRY
INTERMEDIATE 2

Fill in these boxes and read what is printed below.

Full name of centre

--

Town

--

Forename(s)

--

Surname

--

Date of birth

Day Month Year

--	--	--	--	--	--

Scottish candidate number

--	--	--	--	--	--	--	--	--	--

Number of seat

--

Necessary data will be found in the Chemistry Data Booklet for Standard Grade and Intermediate 2.

Section A – Questions 1–30 (30 marks)

Instructions for completion of **Section A** are given on page two.

For this section of the examination you must use an **HB pencil**.

Section B (50 marks)

All questions should be attempted.

The questions may be answered in any order but all answers are to be written in the spaces provided in this answer book, **and must be written clearly and legibly in ink**.

Rough work, if any should be necessary, should be written in this book, and then scored through when the fair copy has been written. If further space is required, a supplementary sheet for rough work may be obtained from the Invigilator.

Additional space for answers will be found at the end of the book. If further space is required, supplementary sheets may be obtained from the Invigilator and should be inserted inside the **front** cover of this booklet.

Before leaving the examination room you must give this book to the Invigilator. If you do not, you may lose all the marks for this paper.



Read carefully

- 1 Check that the answer sheet provided is for **Chemistry Intermediate 2 (Section A)**.
- 2 For this section of the examination you must use an **HB pencil** and, where necessary, an eraser.
- 3 Check that the answer sheet you have been given has **your name, date of birth, SCN** (Scottish Candidate Number) and **Centre Name** printed on it.
Do not change any of these details.
- 4 If any of this information is wrong, tell the Invigilator immediately.
- 5 If this information is correct, **print** your name and seat number in the boxes provided.
- 6 The answer to each question is **either** A, B, C or D. Decide what your answer is, then, using your pencil, put a horizontal line in the space provided (see sample question below).
- 7 There is **only one correct** answer to each question.
- 8 Any rough working should be done on the question paper or the rough working sheet, **not** on your answer sheet.
- 9 At the end of the examination, put the **answer sheet for Section A inside the front cover of this answer book.**

Sample Question

To show that the ink in a ball-pen consists of a mixture of dyes, the method of separation would be

- A chromatography
- B fractional distillation
- C fractional crystallisation
- D filtration.

The correct answer is **A**—chromatography. The answer **A** has been clearly marked in **pencil** with a horizontal line (see below).



Changing an answer

If you decide to change your answer, carefully erase your first answer and using your pencil, fill in the answer you want. The answer below has been changed to **D**.



SECTION A

1. Which of the following is an element?

- A Water
- B Methane
- C Fluorine
- D Ammonia

2. Which of the following elements has similar chemical properties to argon?

- A Zinc
- B Potassium
- C Krypton
- D Chlorine

3. Which line in the table shows the approximate percentage composition of air?

	Nitrogen	Oxygen	Carbon dioxide	Noble gases
A	78	21	0.03	1
B	21	78	1	0.03
C	1	21	78	0.03
D	0.03	78	1	21

4. Vinegar can be made by dissolving ethanoic acid in water.

Which term describes the water used when making the vinegar?

- A Solute
- B Solvent
- C Solution
- D Saturated

5. The graph below shows the variation of concentration of a reactant with time as a reaction proceeds.

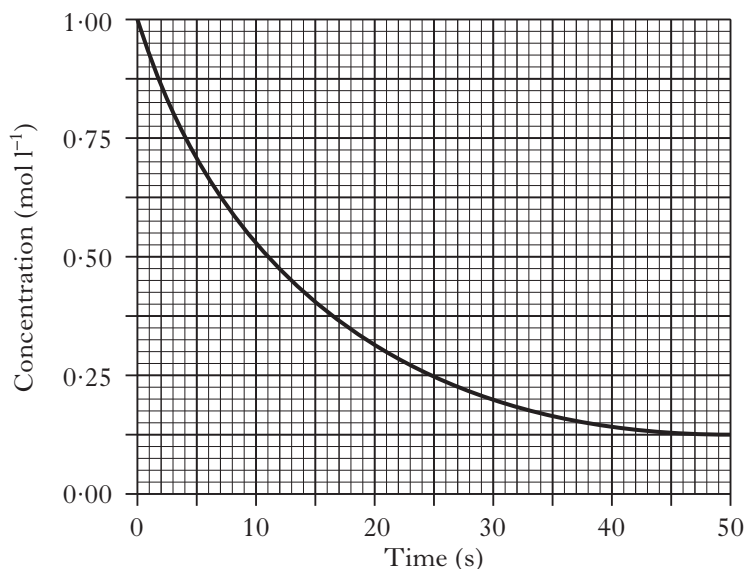

During the first 25 s, the average reaction rate, in $\text{mol l}^{-1} \text{s}^{-1}$, is

- A 0.01
- B 0.02
- C 0.03
- D 0.04.

6. Which of the following pairs of reactants would produce hydrogen most slowly?

- A Magnesium powder and 4 mol l^{-1} hydrochloric acid
- B Magnesium powder and 2 mol l^{-1} hydrochloric acid
- C Magnesium ribbon and 4 mol l^{-1} hydrochloric acid
- D Magnesium ribbon and 2 mol l^{-1} hydrochloric acid

7. An atom is neutral because

- A the number of electrons equals the total number of protons plus neutrons
- B the number of neutrons equals the total number of electrons plus protons
- C the number of protons equals the number of neutrons
- D the number of electrons equals the number of protons.

8. 2,8,8 is the electron arrangement for an atom of an element belonging to the
- halogens
 - noble gases
 - alkali metals
 - transition metals.
9. A compound of iron has the formula $\text{Fe}(\text{NO}_3)_3$.
The charge on the iron ion in this compound is
- 1+
 - 3+
 - 1-
 - 3-
10. 0.2 mol of gas has a mass of 12.8 g.
Which of the following could be the molecular formula for the gas?
- SO_2
 - CO
 - CO_2
 - NH_3
11. In a displacement reaction, **1 mole** of aluminium was added to excess copper(II) sulphate solution.
- $$2\text{Al}(\text{s}) + 3\text{CuSO}_4(\text{aq}) \longrightarrow 3\text{Cu}(\text{s}) + \text{Al}_2(\text{SO}_4)_3(\text{aq})$$
- How many moles of copper are produced in this reaction?
- 3.0
 - 2.0
 - 1.5
 - 1.0.
12. Which air pollutant found in car exhausts is **not** produced as a result of incomplete combustion of the fuel?
- Nitrogen dioxide
 - Carbon monoxide
 - Carbon
 - Unburned hydrocarbons
13. Which of the following is the least viscous?
- Diesel
 - Petrol
 - Kerosene
 - Lubricating oil

14. Three members of the cycloalkene homologous series are:

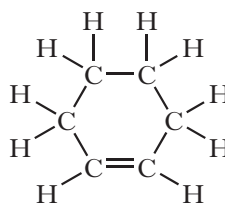
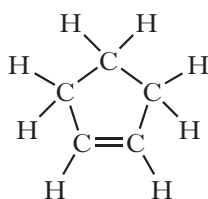
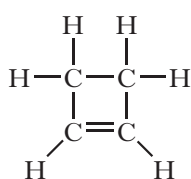

The general formula for this homologous series is

- $\text{C}_n\text{H}_{2n-2}$
- $\text{C}_n\text{H}_{2n-4}$
- C_nH_{2n}
- $\text{C}_n\text{H}_{2n+2}$.

15.

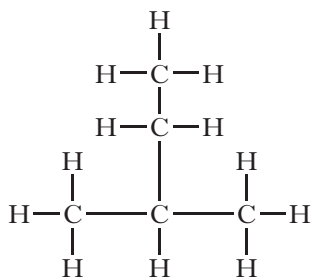

The name of the above compound is

- A 1,1-dimethylpropane
- B 2-ethylpropane
- C 2-methylbutane
- D 3-methylbutane.

16. Which of the following molecules is an isomer of heptane?

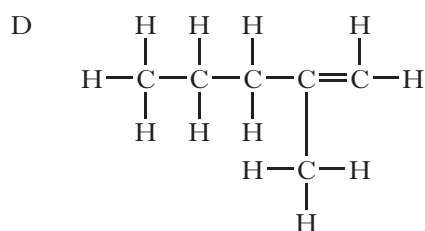
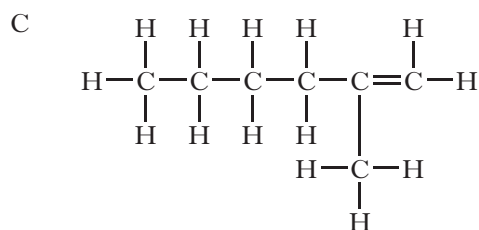
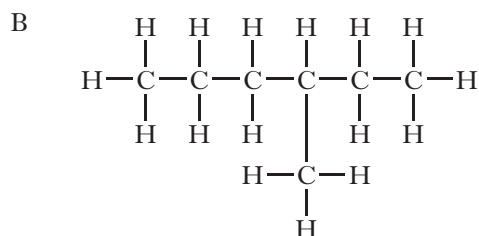
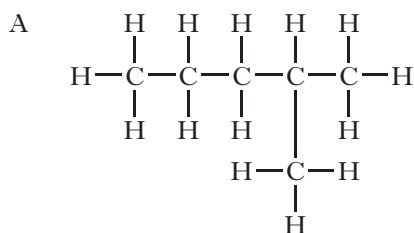

17. Which of the following compounds fits the general formula, C_nH_{2n} , and will rapidly decolourise bromine solution?

- A Cyclopentane
- B Cyclopentene
- C Pentane
- D Pentene

18. A hydrocarbon was cracked.

The equation for one reaction that takes place is shown.

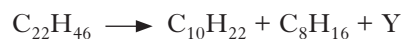

What is the molecular formula for Y?

- A C_3H_8
- B C_4H_8
- C C_4H_{10}
- D C_5H_{12}

19. Which process is represented by the equation below?

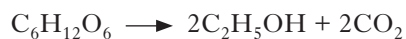

- A Fermentation
- B Combustion
- C Condensation
- D Photosynthesis

20. Which polymer dissolves readily in water?

- A Polystyrene
- B Nylon
- C Poly(ethenol)
- D Kevlar

[Turn over

21. Part of the structure of a polymer is drawn below.

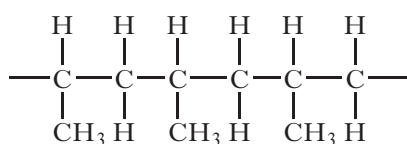

The monomer used to make this polymer is

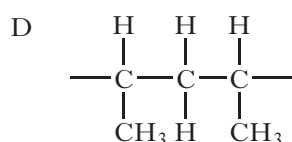
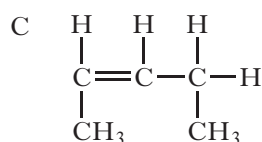
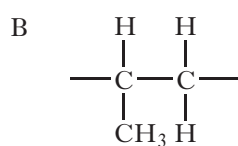
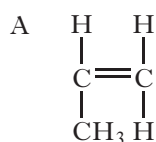

22. Which of the following molecular formulae could be that for a carbohydrate?

- A $\text{C}_6\text{H}_6\text{O}$
 B $\text{C}_6\text{H}_6\text{O}_6$
 C $\text{C}_6\text{H}_8\text{O}_6$
 D $\text{C}_6\text{H}_{12}\text{O}_6$

23. What is the ratio of glycerol molecules to fatty acid molecules produced on the hydrolysis of a fat or oil?

- A 1 : 1
 B 1 : 2
 C 1 : 3
 D 1 : 4

24. Which of the following oxides, when shaken with water, would leave the pH unchanged?

(You may wish to use page 5 of the data booklet to help you.)

- A Carbon dioxide
 B Copper oxide
 C Sodium oxide
 D Sulphur dioxide

25. Which compound would **not** neutralise hydrochloric acid?

- A Sodium carbonate
 B Sodium chloride
 C Sodium hydroxide
 D Sodium oxide

26. In which of the following test tubes will a gas be produced?

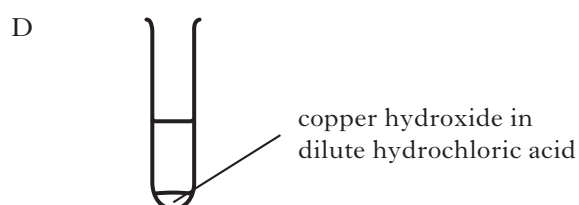
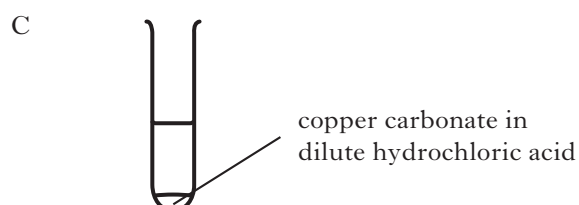
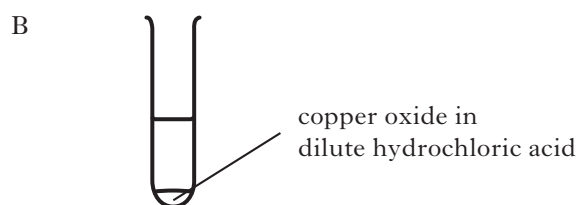
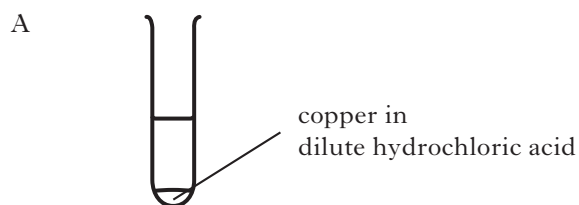

27. Hydrogen gas
- A burns with a pop
 - B relights a glowing splint
 - C turns damp pH paper red
 - D turns limewater cloudy.

28. Which of the following salts could **not** be used as a fertiliser to supply the element nitrogen?
- A Ammonium nitrate
 - B Ammonium sulphate
 - C Potassium nitrate
 - D Potassium sulphate.

29. The diagram below shows what happens when two solutions are mixed.

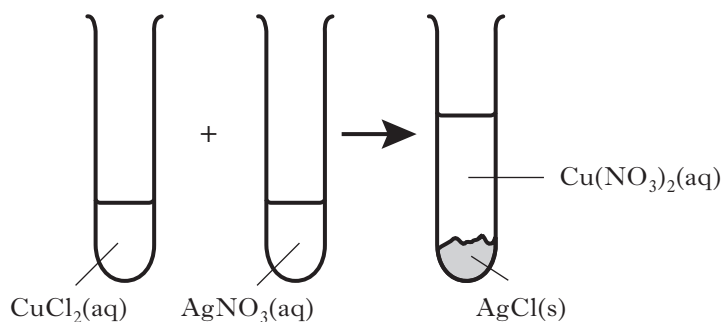

Which of the following terms describe the reaction that has taken place?

- A Addition
- B Neutralisation
- C Precipitation
- D Redox

30. The table contains information about calcium and calcium chloride.

	Melting Point (°C)	Density (g cm⁻³)
Calcium	842	1.54
Calcium chloride	772	2.15

When molten calcium chloride is electrolysed at 800°C the calcium appears as a

- A solid on the surface of the molten calcium chloride
- B liquid on the surface of the molten calcium chloride
- C solid at the bottom of the molten calcium chloride
- D liquid at the bottom of the molten calcium chloride.

Candidates are reminded that the answer sheet for Section A MUST be placed INSIDE the front cover of this answer book.

[Turn over

SECTION B**50 marks are available in this section of the paper.****All answers must be written clearly and legibly in ink.**

1. The element polonium was discovered by the scientist Marie Curie.
An isotope of polonium is shown.



- (a) How many neutrons are present in an atom of ${}_{84}^{210}\text{Po}$?

1

- (b) What is meant by the term isotopes?

1

Marks

1. (continued)

- (c) The isotope $^{210}_{84}\text{Po}$ is radioactive and the level of radioactivity decreases over time as shown.

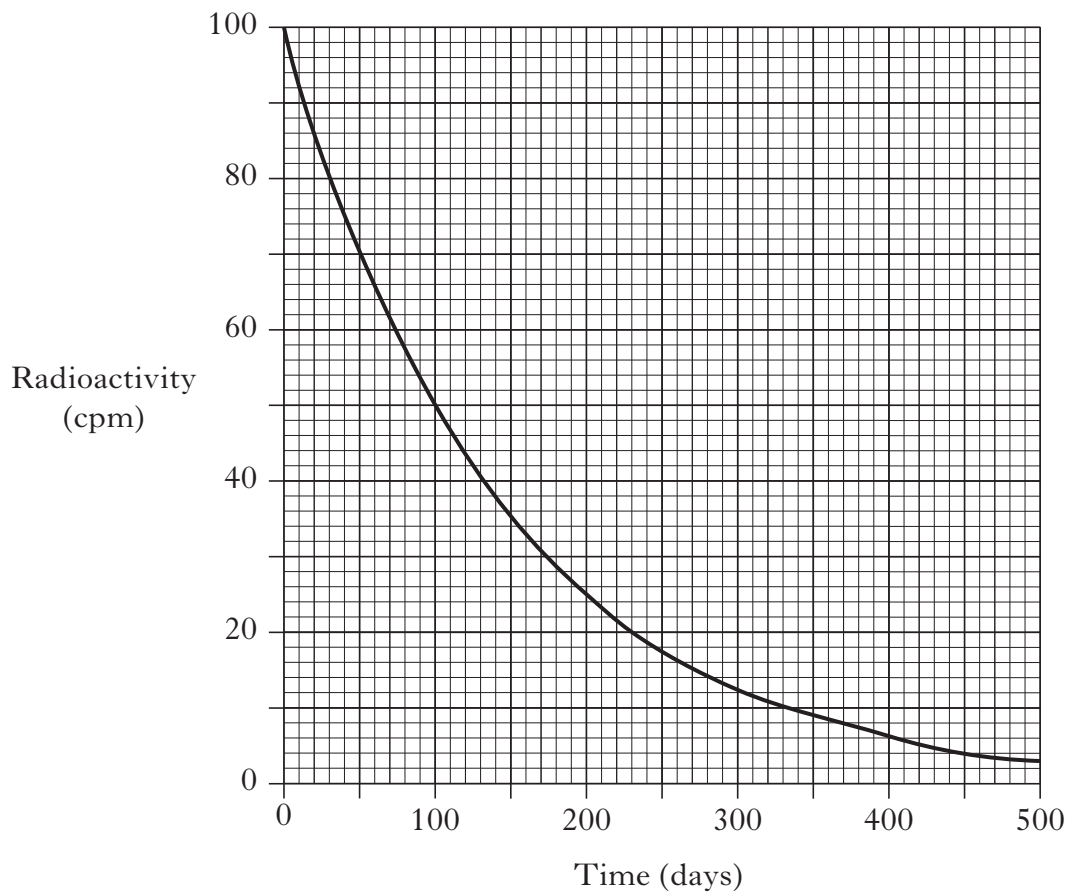

How long would it take for the radioactivity to fall from 100 cpm to 20 cpm?

_____ days **1**
(3)

[Turn over

Marks

2. Chloroform, CHCl_3 , was once widely used as an anaesthetic.
A diagram of a molecule of chloroform is shown.

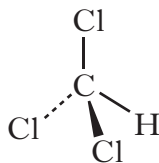

- (a) What term is used to describe the **shape** of this molecule?

1

- (b) One use of chloroform today is in the production of chlorodifluoromethane, CHClF_2 , and hydrogen chloride, HCl .

- (i) **Circle** the correct words to complete the sentence.

Chlorodifluoromethane exists as molecules. The bonds between

the molecules are $\left\{ \begin{array}{l} \text{weak} \\ \text{strong} \end{array} \right\}$, the bonds within the molecules are

$\left\{ \begin{array}{l} \text{weak} \\ \text{strong} \end{array} \right\}$.

1

- (ii) Hydrogen chloride contains a polar covalent bond.

Why is the bond in hydrogen chloride described as polar covalent?

1

(3)

Marks

3. Chlorine gas can be formed in the laboratory by adding concentrated hydrochloric acid to potassium permanganate. The gas is bubbled through water, to remove any unreacted hydrochloric acid, and then concentrated sulphuric acid to dry it. The chlorine gas is then collected in a gas jar.

(a) Label the diagram for the preparation and collection of chlorine.

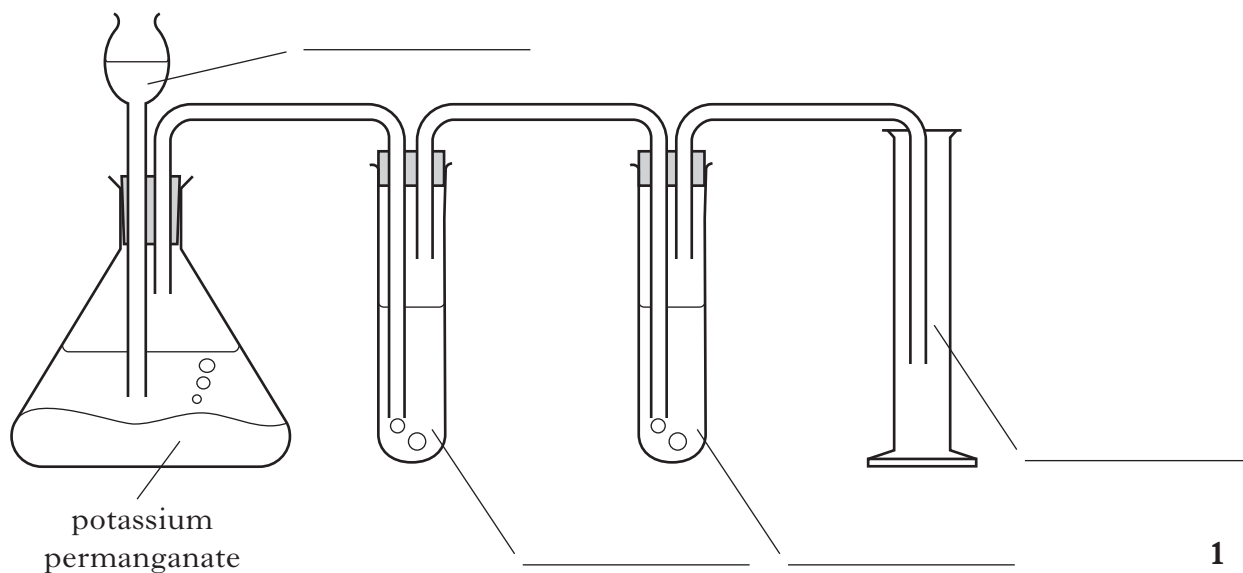

- (b) Draw a diagram to show how the outer electrons are arranged in a molecule of chlorine, Cl_2 .

1
(2)

[Turn over

Marks

4. Hydrogen gas can be used as a fuel.

(a) What is meant by a fuel?

_____ 1

(b) When sodium hydride, NaH, reacts with water, hydrogen and compound **X** are formed.



(i) Name compound **X**.

_____ 1

(ii) Write the **ionic** formula for sodium hydride.

1
(3)

Marks

5. Titanium can be used in the manufacture of bike frames. Titanium is extracted from the ore titanium oxide in several stages.



- (a) The first stage involves converting titanium oxide to titanium chloride, TiCl_4 .

Titanium chloride is a liquid at room temperature.

Suggest the **type** of bonding present in titanium chloride.

_____ 1

- (b) The second stage involves reacting the titanium chloride with sodium in an atmosphere of argon gas.



- (i) Balance this equation.

1

- (ii) What does this reaction indicate about the reactivity of titanium compared to sodium?

_____ 1

- (iii) Suggest why the reaction is carried out in an atmosphere of argon.

_____ 1

(4)

7. Fruit juices such as apple juice contain amino acids.

Marks

(a) Chromatography is a technique which can be used to identify the amino acids present in apple juice. Samples of some known amino acids are spotted on the base line as well as a sample of apple juice. A solvent travels up the paper carrying each amino acid at a different rate.

The amino acids in the apple juice can be identified as they will travel the same distance as the known amino acids.

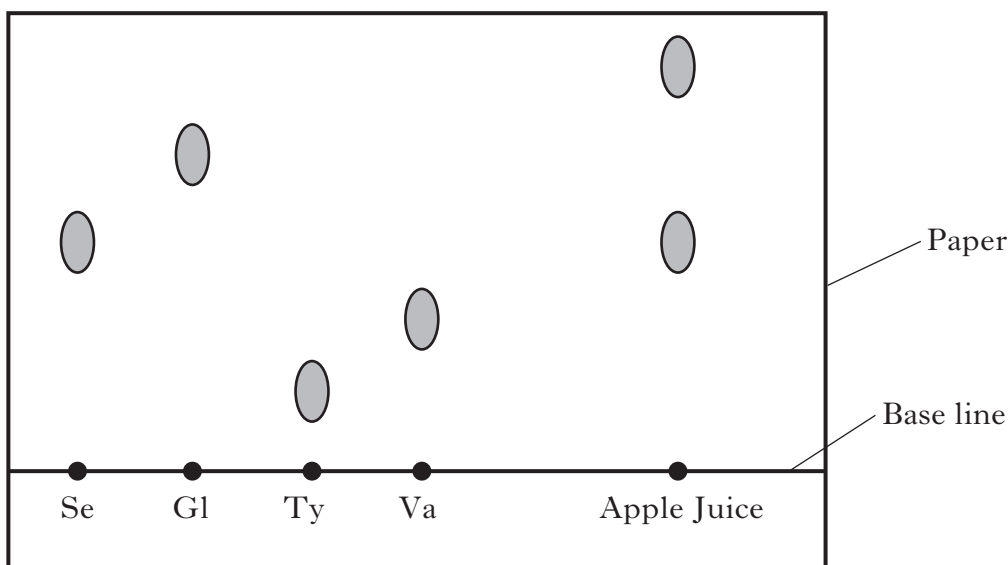

Amino Acid Key: Se = Serine Gl = Glycine
Ty = Tyrosine Va = Valine

The apple juice contains 2 amino acids.

(i) Name the amino acid in the apple juice which can be identified.

_____ 1

(ii) Why can one of the amino acids present in the apple juice **not** be identified?

_____ 1

(b) The body can take the amino acids in apple juice and join them together to form proteins.

Name the link formed when amino acids join together.

_____ 1
(3)

Marks

8. Succinic acid is a natural antibiotic.

The structure of succinic acid is shown.

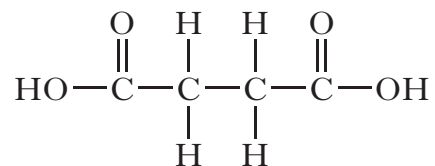

- (a) Name the functional group present in succinic acid.

1

- (b) Succinic acid can form a polymer with ethane-1,2-diol.

The structure of ethane-1,2-diol is shown.

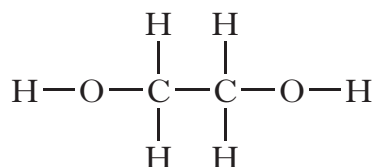

- (i) What type of polymerisation would take place between succinic acid and ethane-1,2-diol?

1

- (ii) Draw the repeating unit of the polymer formed between succinic acid and ethane-1,2-diol.

1**(3)**

Marks

9. Butter is an example of a fat of animal origin while olive oil is of vegetable origin.



- (a) Why are fats and oils an important part of a balanced diet?

1

- (b) The table lists the melting points of both butter and olive oil.

Fat/Oil	Melting point (°C)
butter	35
olive oil	-6

Why does olive oil have a lower melting point than butter?

1

- (c) Oils can be converted into fats. The oils are reacted with hydrogen using the transition metal nickel as a catalyst.

What **type** of catalyst is the nickel?

1

(3)

[Turn over

Marks

10. The ester methyl butanoate smells of pineapple and is used in air fresheners.

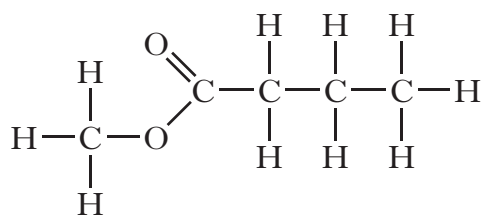

- (a) After some time, the smell fades due to the methyl butanoate being broken down.

Name the process by which methyl butanoate is broken down.

_____ 1

- (b) Draw a structural formula for the alcohol formed when methyl butanoate is broken down.

_____ 1
(2)

Marks

11. A student set up the following apparatus to measure the voltage of cells using different combinations of metals.

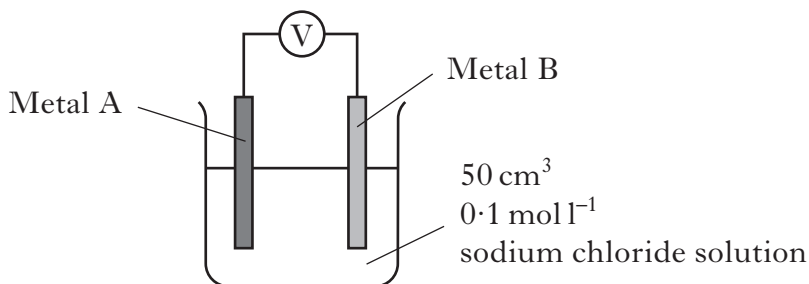

- (a) State **one** factor which would have to be kept the same to make this investigation fair.

1

- (b) Voltages were produced by the following combinations of metals.

Metal A	Metal B	Voltage (V)
magnesium	lead	2.25
magnesium	iron	1.94
magnesium	zinc	1.62
magnesium	aluminium	0.72

- (i) What effect does the reactivity of a metal have on the voltage it produces with magnesium?

1

- (ii) Predict the voltage which would be produced when Metal A is magnesium and Metal B is copper.

_____ V

1

- (c) What is the purpose of the sodium chloride solution?

1

(4)

Marks

12. A student was asked to carry out an experiment to determine the concentration of a copper(II) sulphate solution.

Part of the work card used is shown.

Determination of the Concentration of Copper(II) Sulphate Solution

- 1 Weigh an empty crucible
- 2 Add 100 cm³ copper(II) sulphate solution
- 3 Evaporate the solution to dryness
- 4 Weigh the crucible containing dry copper(II) sulphate

- (a) Suggest how the student could have evaporated the solution to dryness.

_____ 1

- (b) The student found that the 100 cm³ solution contained 3.19 g of copper(II) sulphate, CuSO₄.

Calculate the concentration of the solution in mol l⁻¹.

_____ mol l⁻¹ 2
(3)

Marks

13. When aluminium is exposed to air it corrodes.

(a) Some structures have aluminium and iron parts held together by bolts.

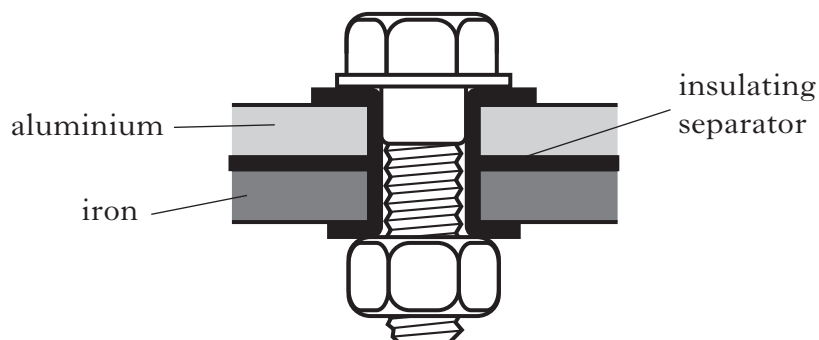

Why would the aluminium corrode more quickly if the separator was not present?

1

(b) The corrosion of aluminium is an example of oxidation.

Write an ion-electron equation for the oxidation of aluminium.

1

(c) During the corrosion of aluminium, it forms a layer of aluminium oxide.

How does this layer protect the aluminium from further corrosion?

1

(3)

[Turn over

14. A student carried out a PPA to prepare the salt, magnesium sulphate.

(a) Part of the student's PPA assessment sheet is shown.

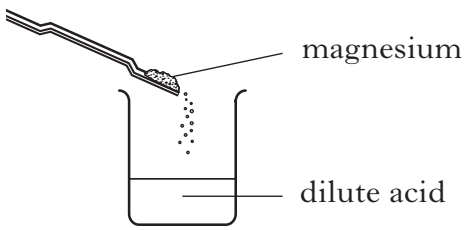
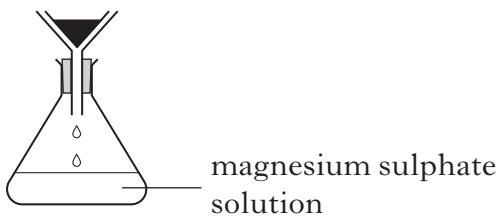
Intermediate 2		Unit 3
Chemistry	Preparation of a Salt	PPA1
Assessment Sheet		
Aim To prepare a pure sample of magnesium sulphate.		
Procedure		
Step 1 reaction		
Step 2 filtration		

(i) Name the acid used to make this salt.

_____ 1

(ii) How would the student know when to stop adding magnesium in Step 1?

_____ 1

(iii) Why was the reaction mixture filtered in Step 2?

_____ 1

Marks

14. (continued)

- (b) The pH of a salt depends on whether the acid and base used to make it are weak or strong.

Base	Acid	Salt	pH
sodium hydroxide	hydrochloric acid	sodium chloride	7
sodium hydroxide	ethanoic acid	sodium ethanoate	12
ammonia	hydrochloric acid	ammonium chloride	3
sodium hydroxide	citric acid	sodium citrate	12

From this information, what type of acid is citric acid?

1
(4)

[Turn over

Marks

15. Vitamin C is found in fruits and vegetables.

(a) Vitamin C is an acid and has a pH value of less than 7.

What is meant by an acid?

1

(b) Using iodine solution, a student carried out titrations to determine the concentration of vitamin C in orange juice.

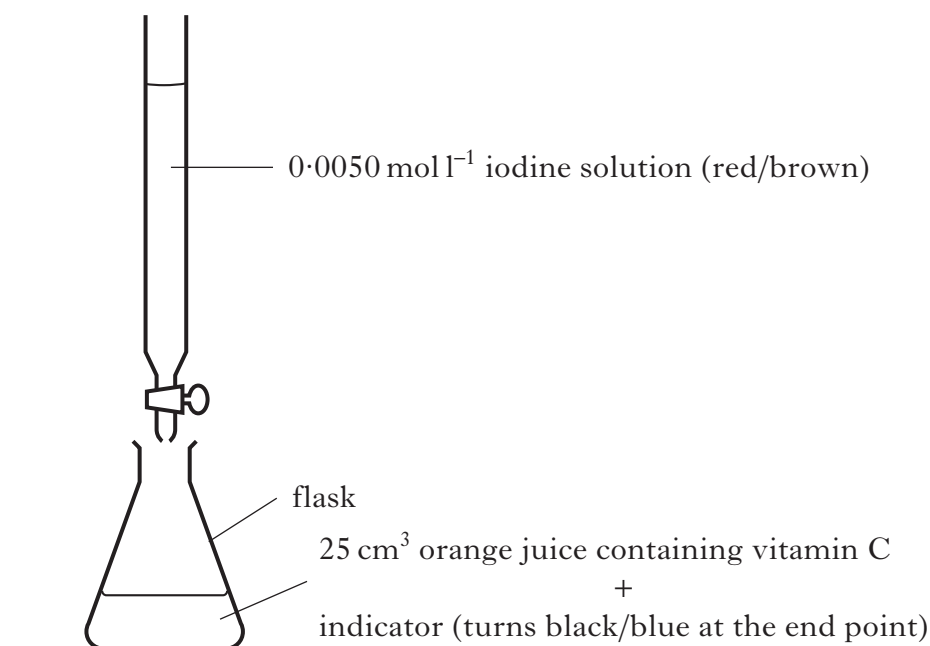

(i) Name the indicator used in this titration.

1

The results of the titration are given in the table.

Titration	Initial burette reading (cm ³)	Final burette reading (cm ³)	Titre (cm ³)
1	1.2	18.0	16.8
2	18.0	33.9	15.9
3	0.5	16.6	16.1

(ii) What average volume should be used in calculating the concentration of vitamin C?

_____ cm³

1

Marks

15. (b) (continued)

- (iii) The equation for the reaction between vitamin C and iodine solution is shown.



Calculate the concentration of vitamin C in the orange juice.

_____ mol l⁻¹ 2
(5)

[Turn over

Marks

16. The diagram shows a cell which can produce electricity.

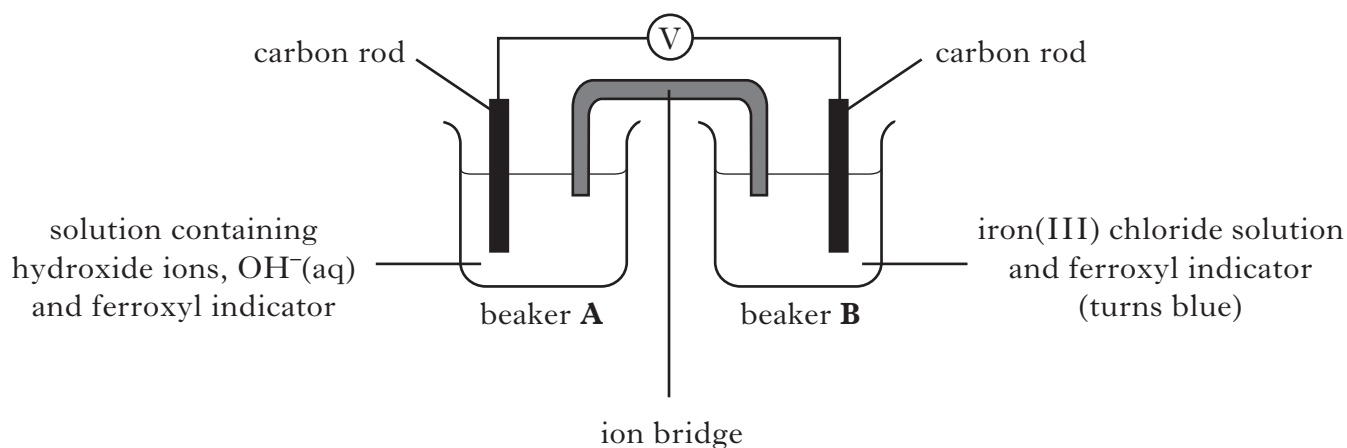

In beaker **A** hydroxide ions are converted into water molecules:



(a) What colour would be seen in beaker **A**?

1

(b) On the diagram, clearly mark the path and the direction of the electron flow.

1

(2)

[END OF QUESTION PAPER]

ADDITIONAL SPACE FOR ANSWERS

--	--

ACKNOWLEDGEMENTS

Section B, Question 5 – Rudy Umans/shutterstock.com

Section B, Question 9 – Robyn Mackenzie/shutterstock.com

Valentyn Vokov/shutterstock.com