

S1 Unit 1 – Electricity



Static Electricity

Electrical Circuits

Measuring Voltage
and Current

Fruit Cell Batteries

Education Scotland Experiences, and Outcomes

SCN 3-09a:

- Having measured the current and voltage in series and parallel circuits, I can design a circuit to show the advantages of parallel circuits in an everyday application.

SCN 3-10a:

- I can help to design simple chemical cells and use them to investigate the factors which affect the voltage produced.

Static Electricity

24/09/2024

Page 3

Starter:

Write down everything you know about electricity



Learning Intentions:

- I am learning about static electricity

Success Criteria

- I can state the two types of charge
- I can describe what happens when two charges are next to each other



Why...

- Do you sometimes get a “shock” when you close a car door?
- Will a balloon stick to a wall once you’ve rubbed it on your head?
- Do surfaces sometimes get even dustier once they have been dusted?

*Because of
Static Electricity!*

Positive and negative charges

All substances are made of Atoms. These are often called particles.

Atoms contain even smaller particles called protons, neutrons and electrons. Protons have a positive charge, electrons have a negative charge and neutrons have no charge.



Positive and negative charges

If an atom **gains** an electron it becomes negatively charged.

If an atom **loses** an electron it becomes positively charged.

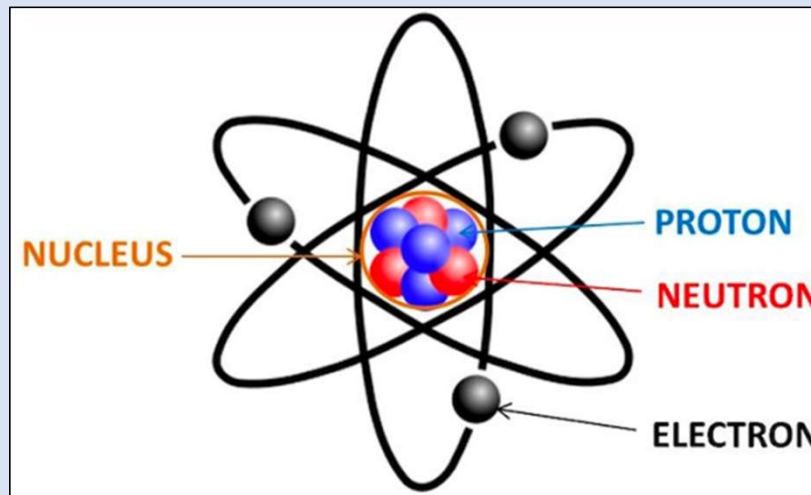

Charged Particles

- Everything has two types of particles in it, **positively** charged particles and **negatively** charged particles.
- When two objects rub together, sometimes some of the charges move from one surface to the other. They are then said to be charged.

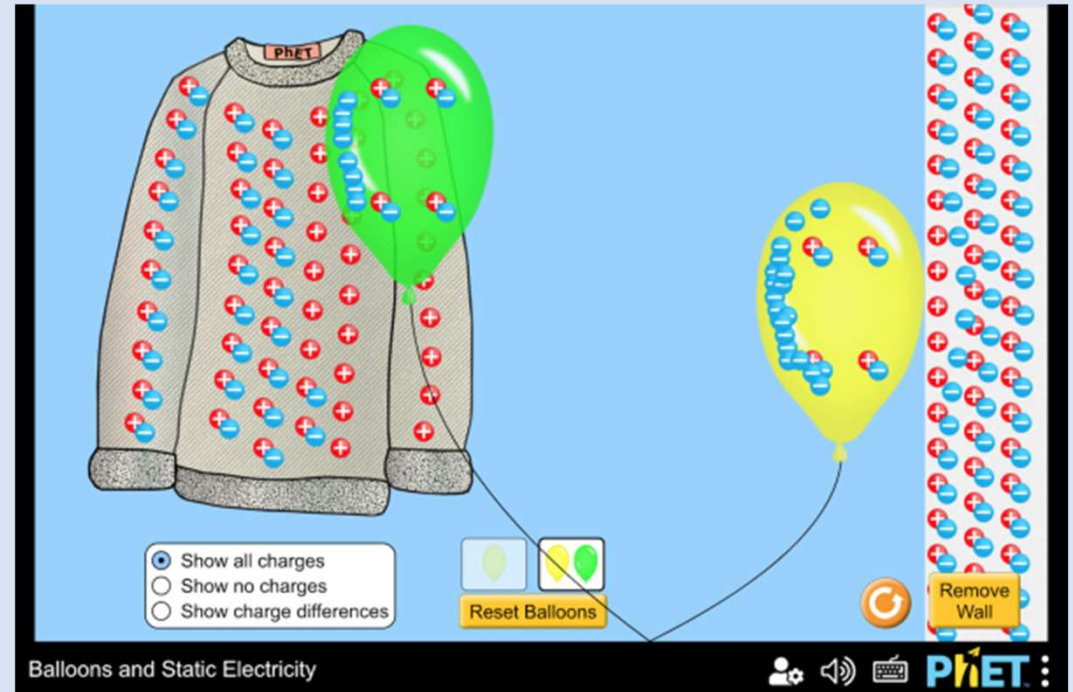

[Balloons and Static Electricity](https://phet.colorado.edu/sims/html/balloons-and-static-electricity/latest/balloons-and-static-electricity_en.html)

https://phet.colorado.edu/sims/html/balloons-and-static-electricity/latest/balloons-and-static-electricity_en.html

Static Electricity

Aim: To investigate the effects of static electricity

Method:

Experiment 1

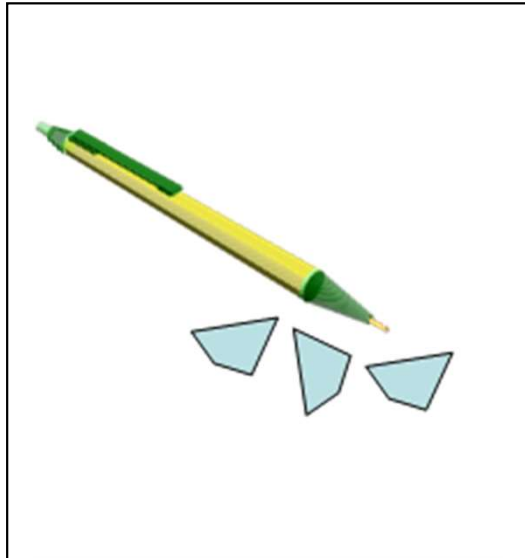

Experiment 2

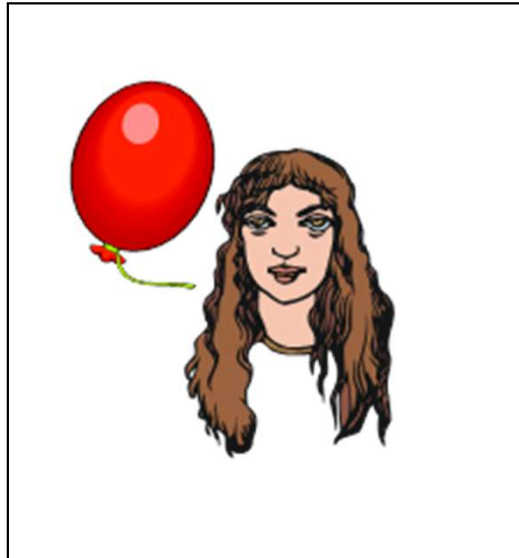

Experiment 3

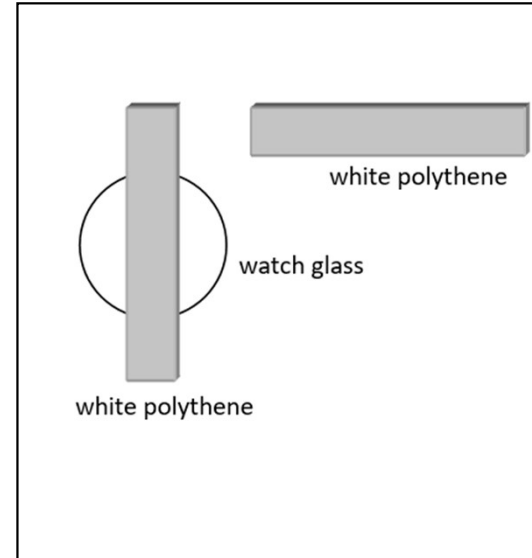

Aim: To investigate the effects of static electricity

Method:

1. Rub your pen with a piece of cloth
2. Try to pick up small pieces of paper
3. Observe what happens

Experiment 1

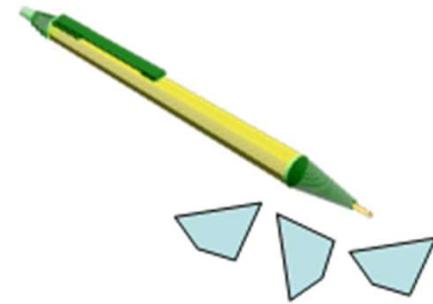

Method:

1. Blow up a balloon
2. Rub the balloon on your head
3. Observe what happens

Experiment 2

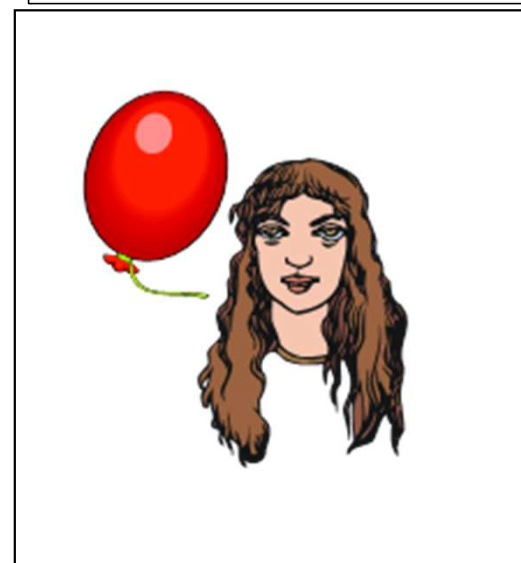

Method:

1. Rub the plastic rod with the cloth
2. Place the other rod on top of a watch glass
3. Observe what happens when the rods almost touch

Experiment 3

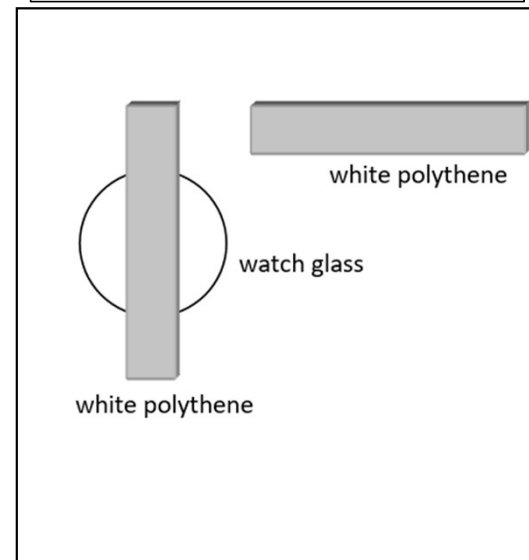

Static Electricity

Results: *answer the following questions*

1. What happens with the pen and paper?
2. What happens with the hair and the balloon?
3. What happens with the rods?
4. Try to explain your answers to the above questions



Static Electricity



Conclusion:

Charges that are the same repel (push away) from each other.

Charges that are different attract (move towards) each other.

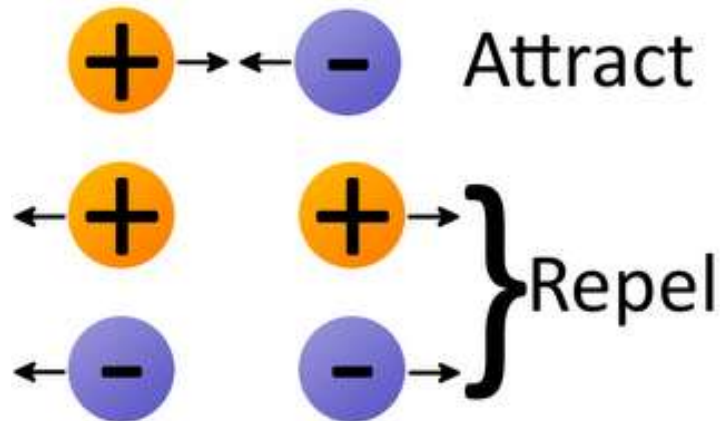

Static Electricity

Activity: Watch the video and note down three facts

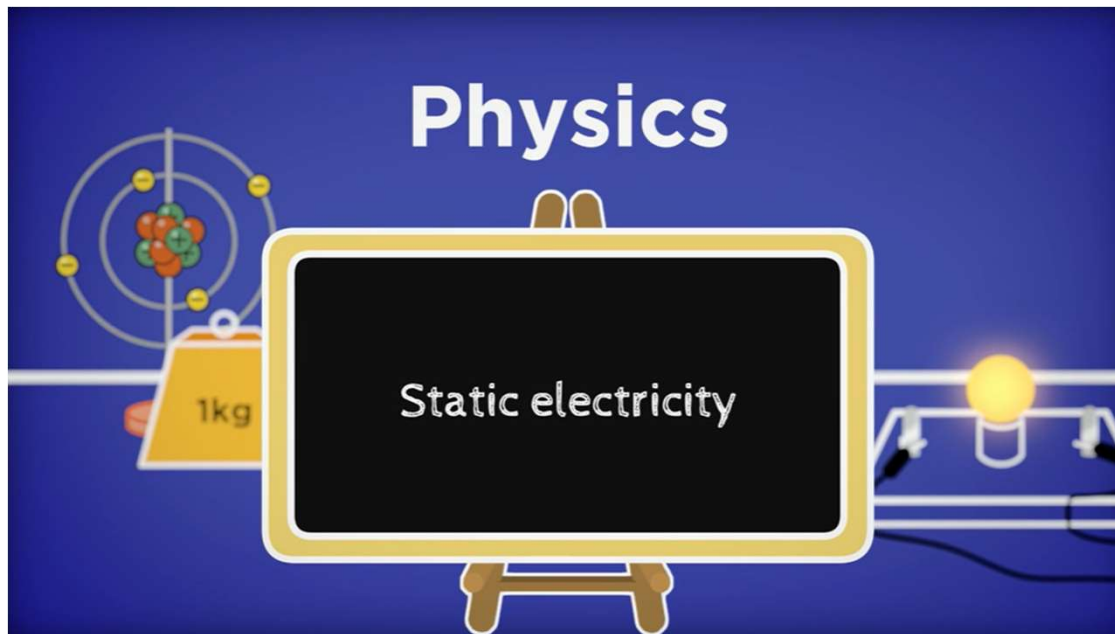

Be
prepared
to share!

<https://www.bbc.co.uk/bitesize/articles/zshqqfr#z7rbbqt>

Static Electricity

24/09/2024

Plenary:

Today I learnt

.....

Success Criteria

- I can state the two types of charge
- I can describe what happens when two charges are next to each other

Tick me at the
end if ***you can***

...

Starter:

1. State the two types of charge.
2. Describe what happens when two charges are next to each other.

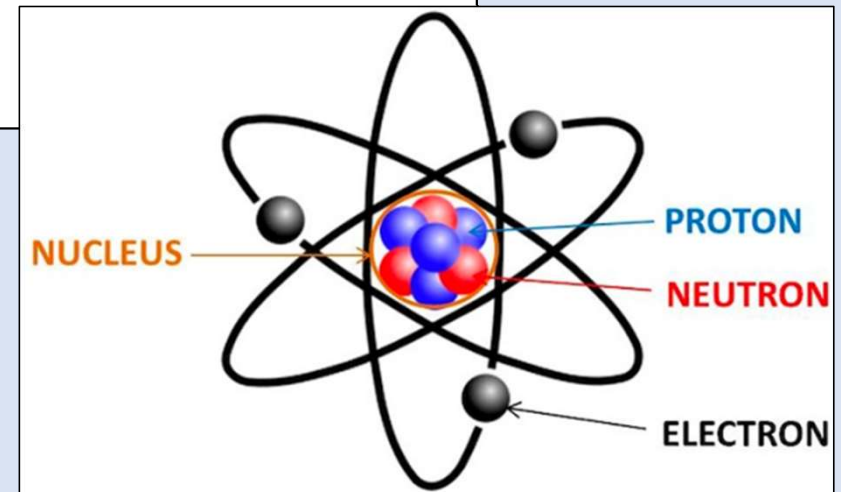

Learning Intentions:

- I am learning about static electricity

Success Criteria

I can explain static electricity in terms of charge

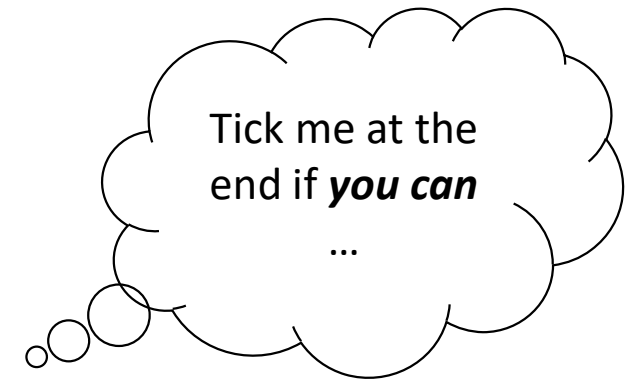

Van de Graaff Generator

A Van de Graaff generator produces Static electricity, which makes your hair stand on end. Static electricity is caused when electrons are transferred from one insulator to another by friction. This causes an uneven number of protons and electrons in a material.



Van de Graaff Generator



https://www.youtube.com/watch?v=rNEY3Yv9kC8&ab_channel=SpanglerScienceTV

Van de Graaff Generator

Uses the fact that like charges repel.

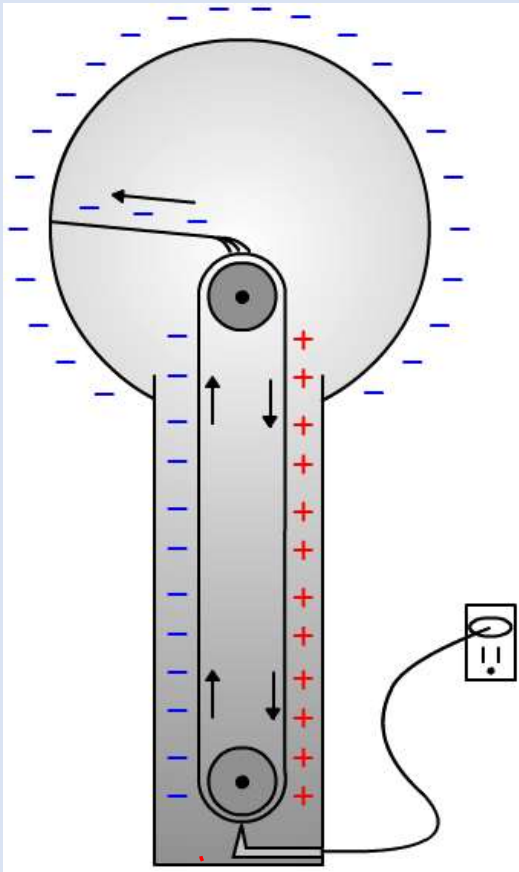

A pulley drives an insulating belt given a **negative charge** by a power supply.

The **negative charge** to spread to the dome.

The voltages generated are enough to make your hair stand on end!

Like charges on individual hairs makes them **repel** each other and stand away from your head.

By standing on a wooden or plastic stool you are isolated from ground so that the **charge** will build up on you.

Van de Graaff Generator

Aim: To investigate the effects of a Van de Graaff generator on different objects



Van de Graaff Generator

Method: *draw a labelled diagram of the Van de Graaf Generator.*

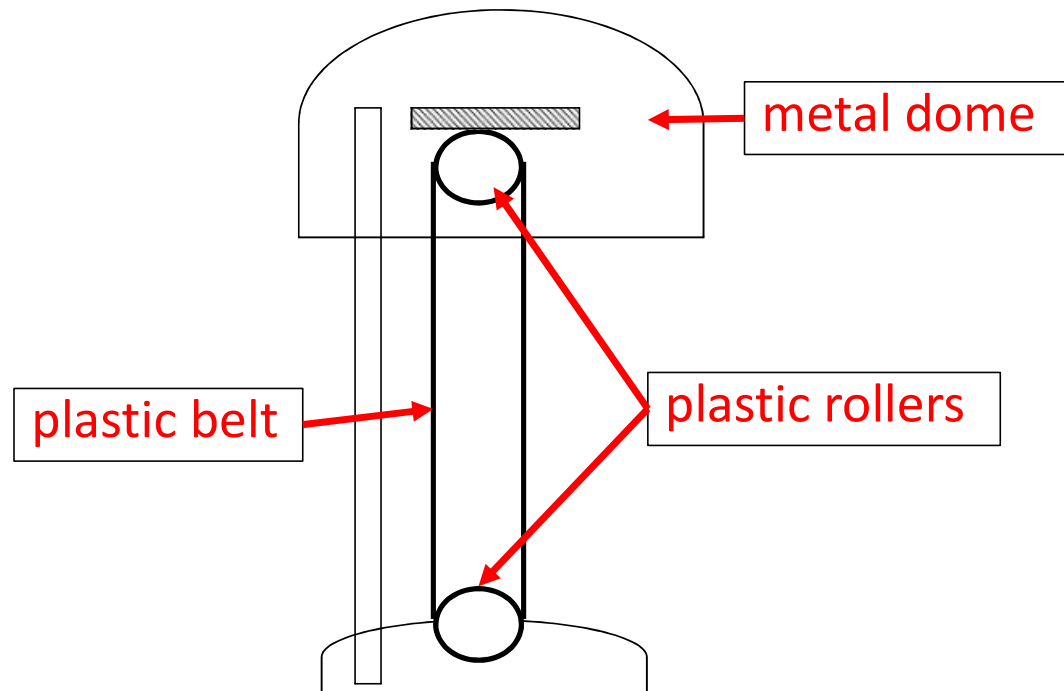

Van de Graaff Generator

Results:

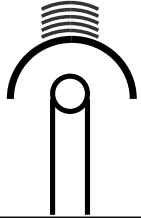
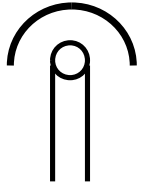
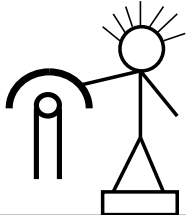
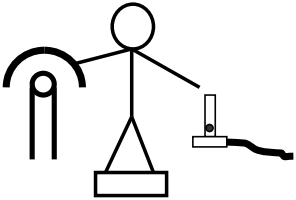
Experiment	Describe what you saw	Explain why
Foil cups 		
Sawdust 		
Hair 		
Gas tap 		



Use words like positive, negative, attract and repel in your explanations

Van de Graaff Generator

Conclusion:

When two different materials are rubbed together they become electrically charged.

Electrically charged objects can attract small objects.

A positively charged object and a negatively charged object will attract.

Two positively charged objects will repel

Two negatively charged objects will repel

Word bank: attract, repel, rubbed, positively, repel, negatively

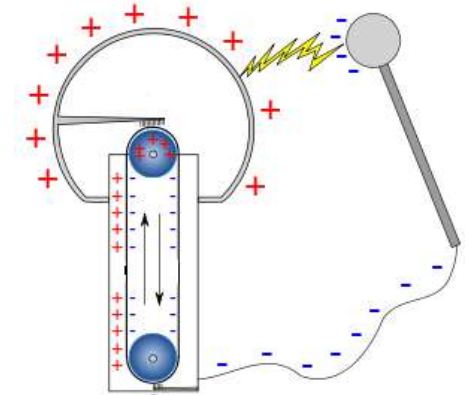

Van de Graaff Generator

24/09/2024

Plenary:

Explain static electricity in terms of charge!

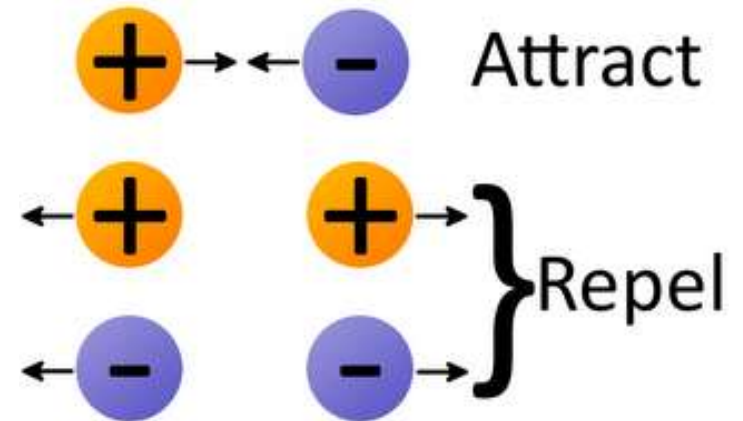

Success Criteria

- I can explain static electricity in terms of charge

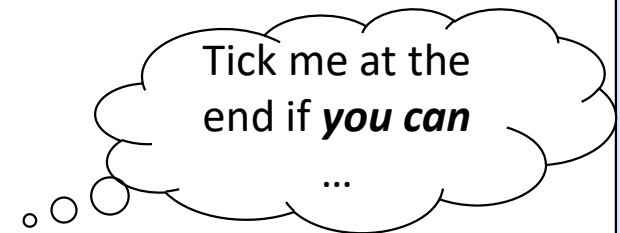

Starter:

When you flip a light switch on, the room instantly lights up. How do you think the switch tells the light bulb to turn on? Write or draw your answer below:



Learning Intentions:

- I am learning about drawing electrical circuits.

Success Criteria

- I can identify the symbols for components in an electrical circuit.
- I can draw simple electrical circuits.

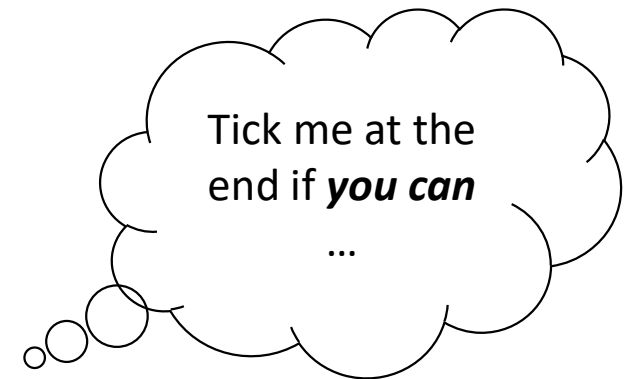

Electrical Circuits

Items that are connected into an electrical circuit are called **components**.

1. Why do you think it is called a “circuit”?
2. What has to happen to make the circuit work?
3. How easy is it to draw the components?

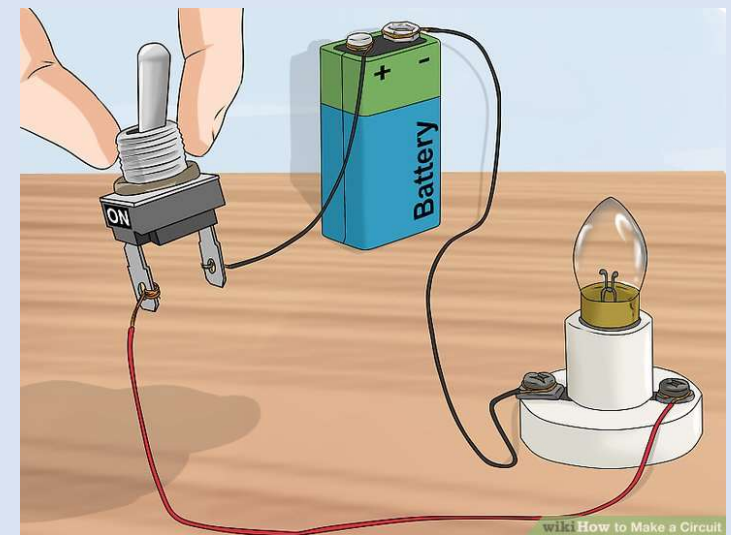

Electrical Circuits

Pictures are:

- difficult to draw
- not always easy to understand

Symbols are:

- easy to draw
- easy to understand

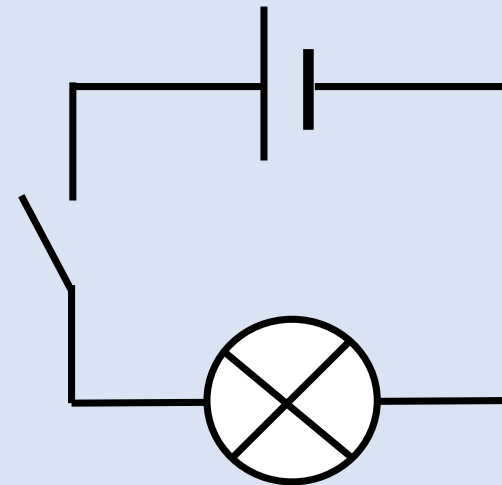
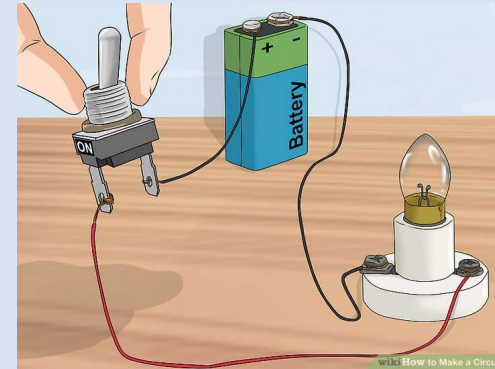

Circuit Diagrams

- When we draw circuits, we draw them like so:

Battery

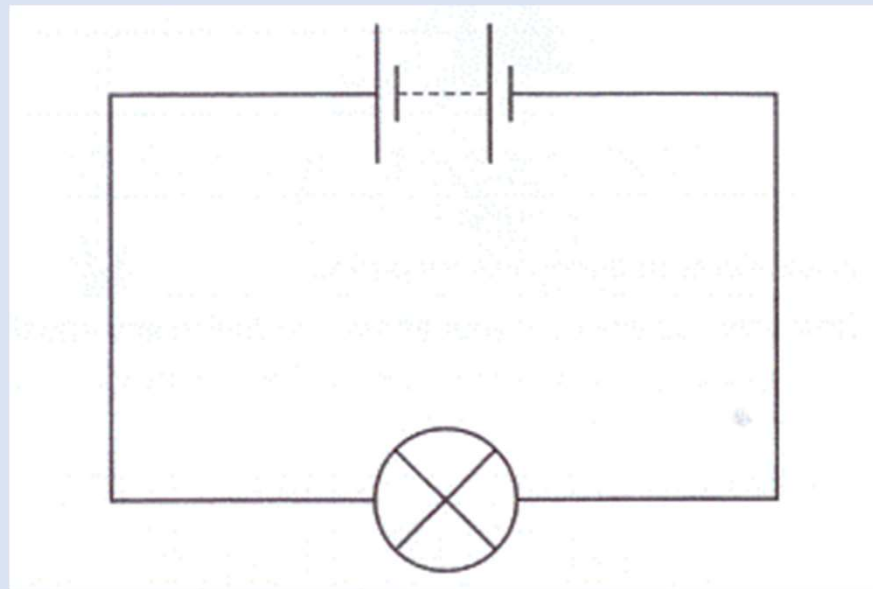

Lamp

Circuit Diagrams

When you are drawing a circuit diagram, there are some basic rules to follow:

Connecting wires are drawn with a **ruler**

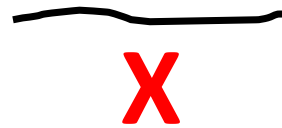

Components don't turn corners, wires do.

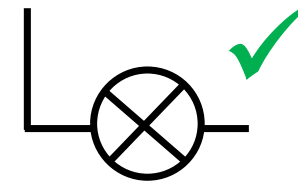
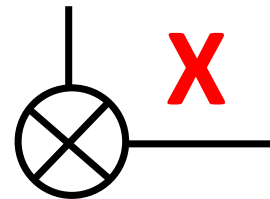



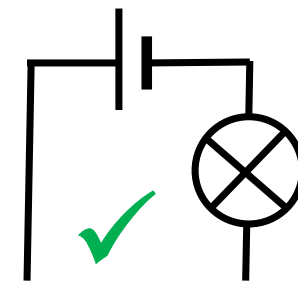
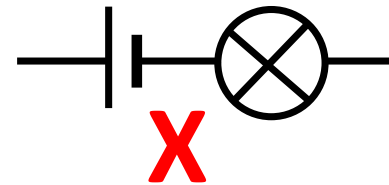







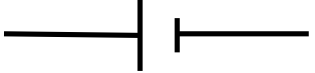



The battery is usually on the top line of the diagram, on its own.



Electrical Symbols

Page 8

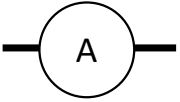
Draw the correct symbol for each of the components.

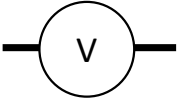
Component Name	Picture	Symbol
Cell		
Battery (of cells)		
Connecting wire		
Lamp		
Switch		
Resistor		
Ammeter		
Voltmeter		



Circuit Diagrams

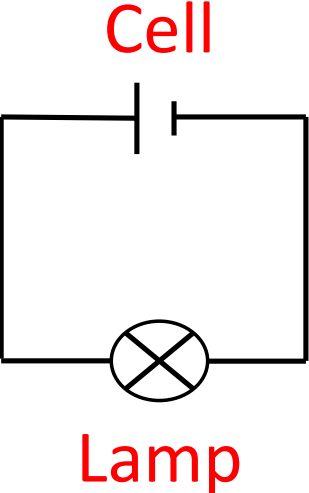

Components	Circuit Diagram
Cell and a lamp	 <p>The diagram shows a rectangular circuit loop. At the top is a cell symbol, consisting of a long vertical line on the left and a shorter, thicker vertical line on the right. Below the cell is a lamp symbol, represented by a circle with an 'X' inside. The word 'Cell' is written in red above the cell symbol, and the word 'Lamp' is written in red below the lamp symbol.</p>

Remember to label your components

Circuit Diagrams

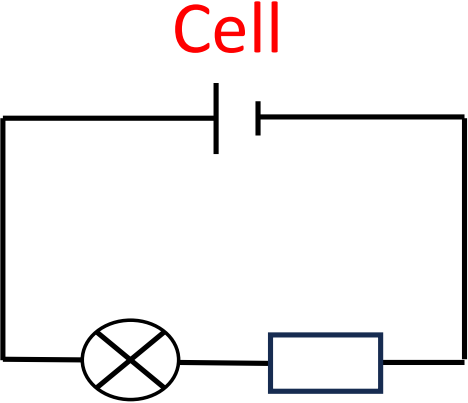

Components	Circuit Diagram
Cell, lamp and resistor	 <p data-bbox="1420 614 1532 667">Cell</p> <p data-bbox="1272 1050 1420 1102">Lamp</p> <p data-bbox="1496 1050 1715 1102">Resistor</p>

Remember to label your components

Circuit Diagrams



Components	Circuit Diagram
Battery, resistor, lamp and switch	<p>The diagram shows a rectangular circuit loop. At the top horizontal wire is a battery symbol, consisting of four cells (long and short vertical lines). Below the battery is the label "Battery" in red. At the bottom horizontal wire, a resistor (represented by a rectangle) and a lamp (represented by a circle with an 'X' inside) are connected in series. Below the resistor is the label "Resistor" in red, and below the lamp is the label "Lamp" in red. On the right vertical wire, there is a switch symbol. To the right of the switch is the label "Switch" in red.</p>

Remember to label your components

Extra Practice: Circuit Diagrams

On your show me boards, draw this circuit

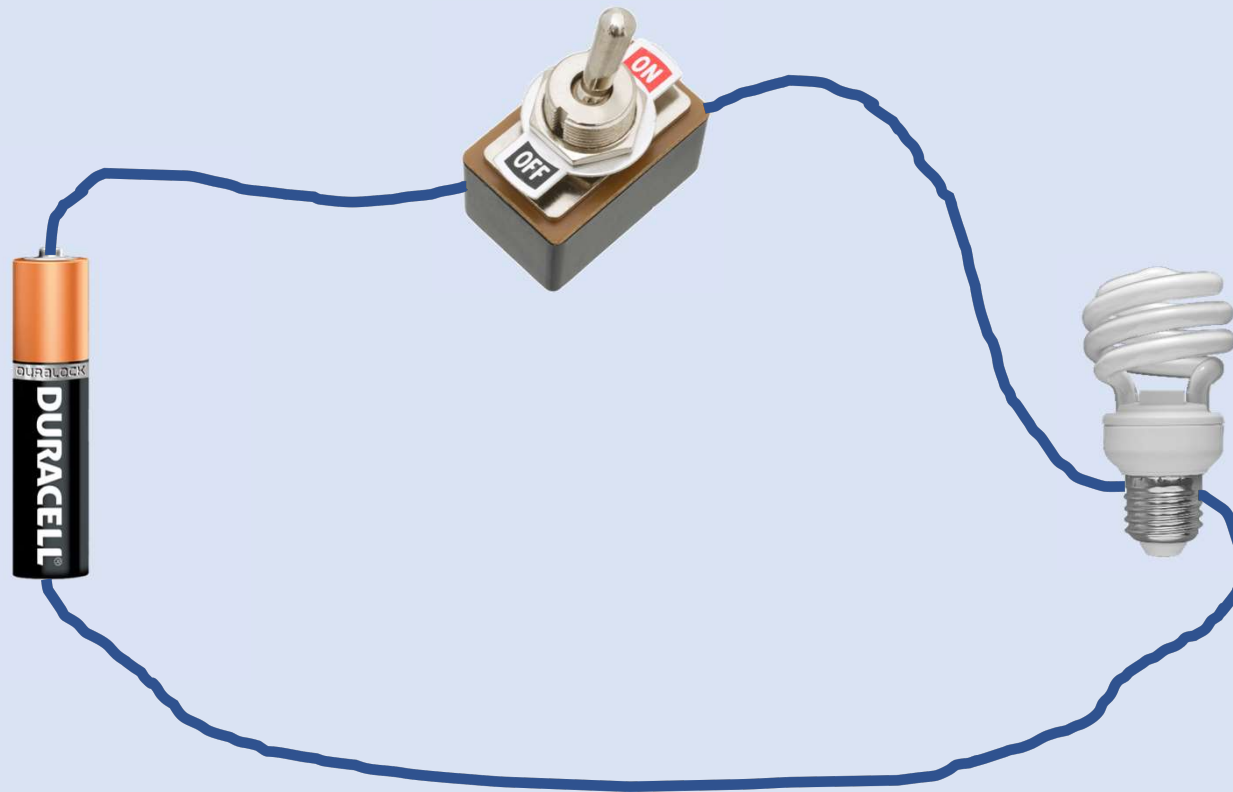

Extra Practice: Circuit Diagrams

Answer

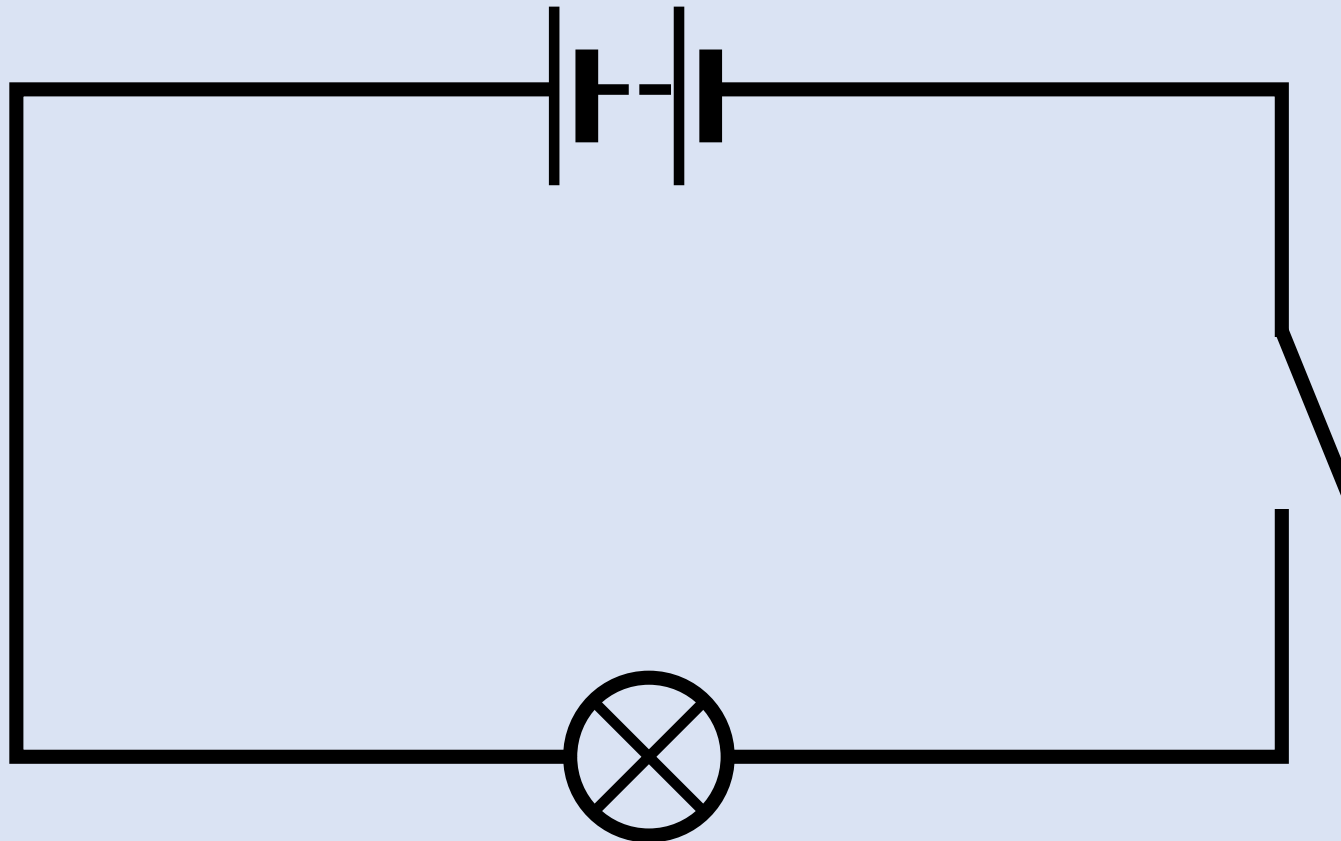

Extra Practice: Circuit Diagrams

On your show me boards, draw this circuit

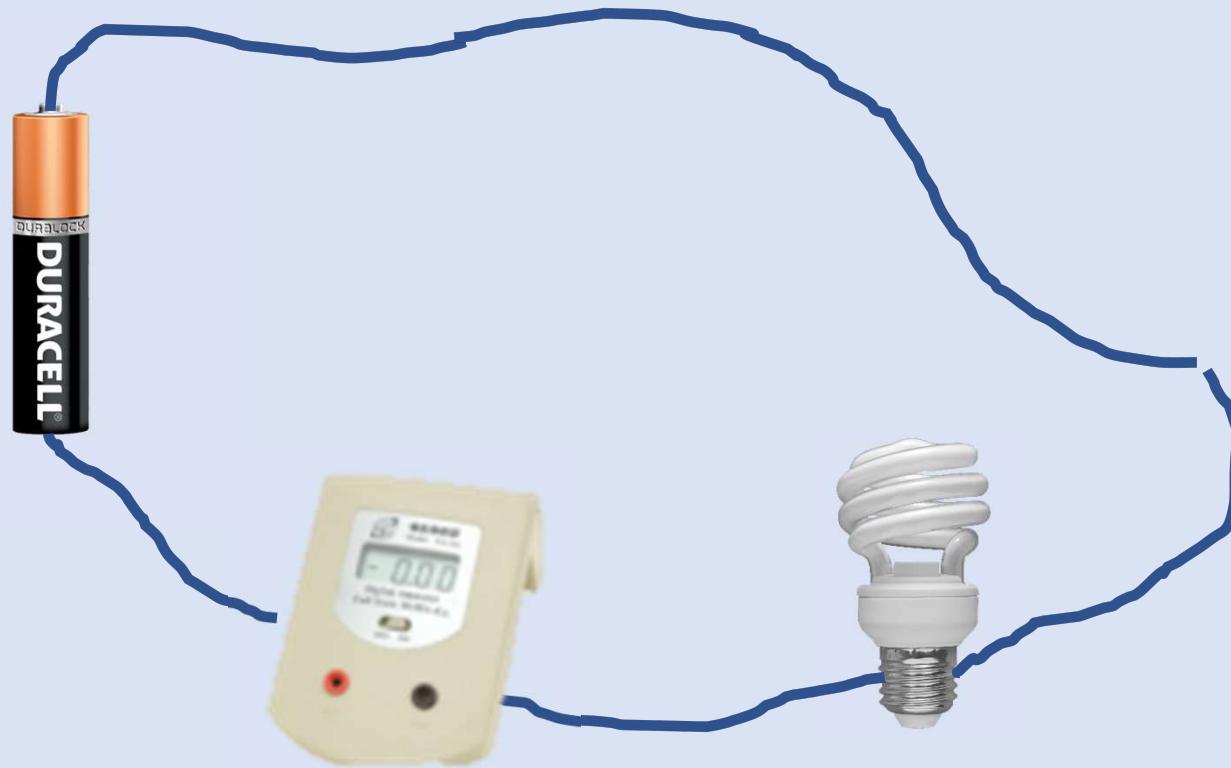

Extra Practice: Circuit Diagrams

Answer

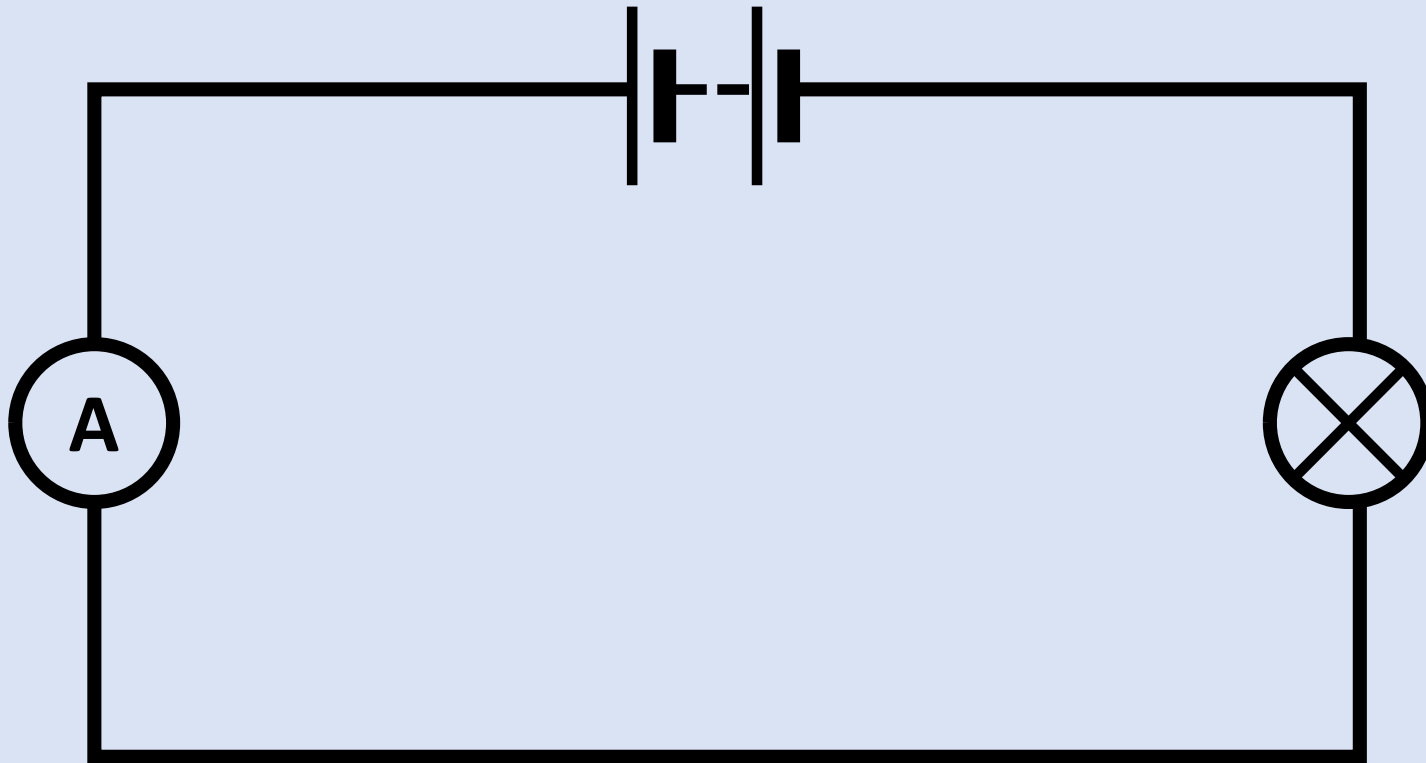

Extra Practice: Circuit Diagrams

On your show me boards, draw this circuit



Extra Practice: Circuit Diagrams

Answer

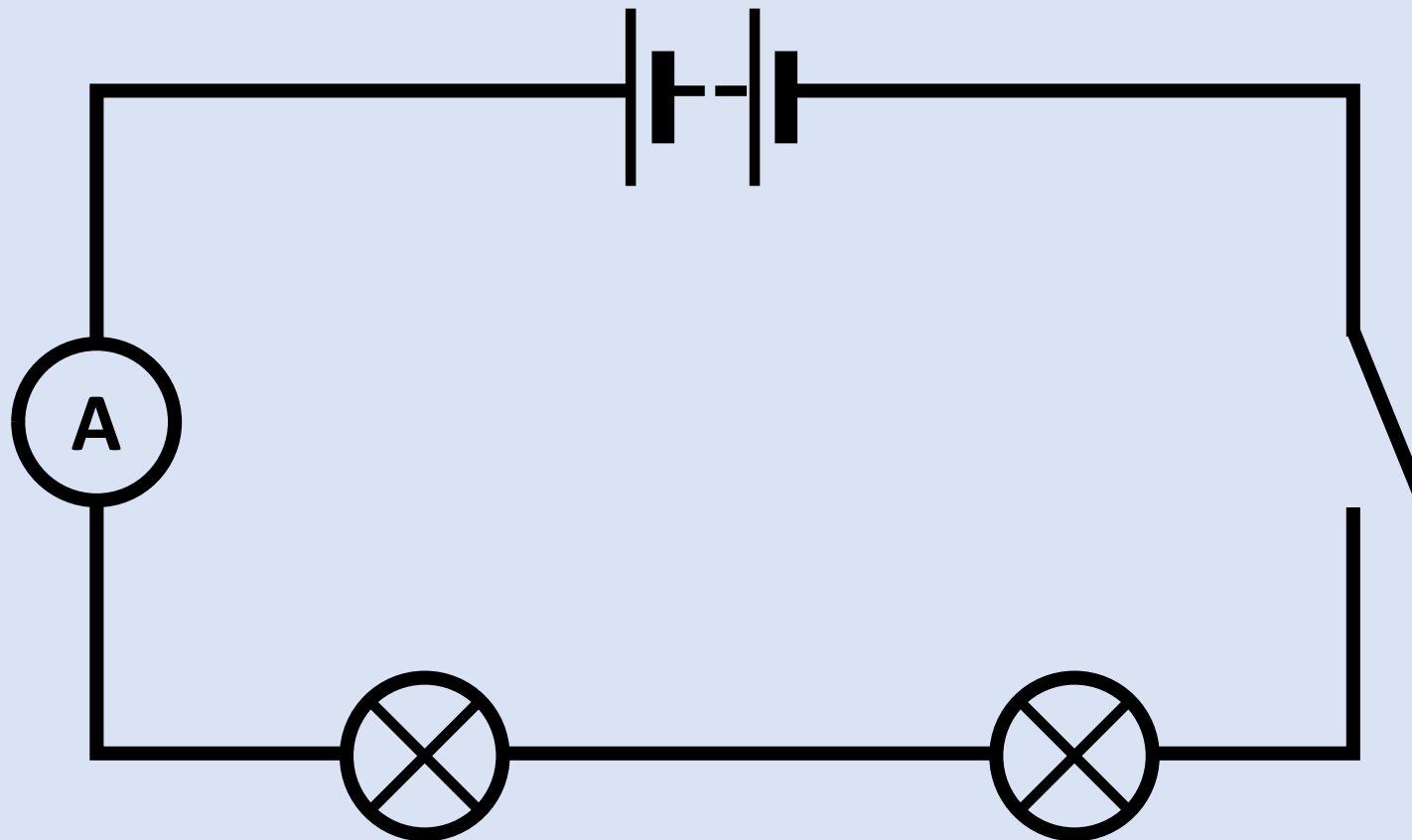

Design a circuit for your partner

- Describe a circuit to your partner and get them to draw what you describe on a Show Me Board.
- You are not allowed to start drawing until the person has finished describing the circuit.



The Story of Electricity

Activity: Watch the video and note down three facts

Shock and Awe - Spark



Be
prepared
to share!

[Shock and Awe: The Story of Electricity- Spark \(1 of 3\) - video Dailymotion](#)

Electrical Circuits

24/09/2024

Plenary: Match the components to the circuit symbol

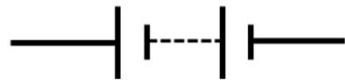

Switch

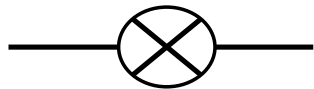

Ammeter

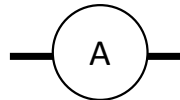

Battery



Lamp

Success Criteria

- I can identify the symbols for components in an electrical circuit.
- I can draw simple electrical circuits.

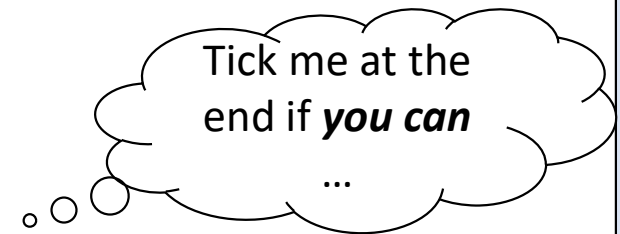

Series Circuits

24/09/2024

Page 10

Starter:

1. What symbol do we use to represent a bulb?

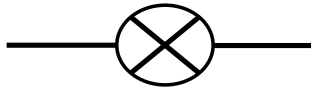

2. What symbol do we use to represent a battery?

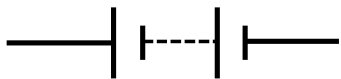

3. What symbol do we use to represent a switch?



4. When we draw wires, what do we need to use?

A ruler!

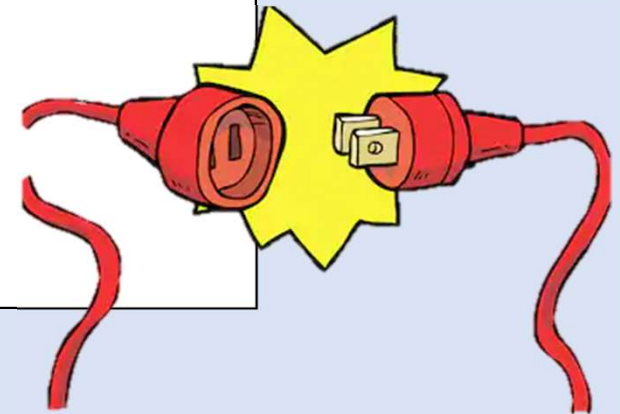

Learning Intentions:

- I am learning about series circuits.

Success Criteria

- I can describe what a series circuit is.
- I can build a series circuit.

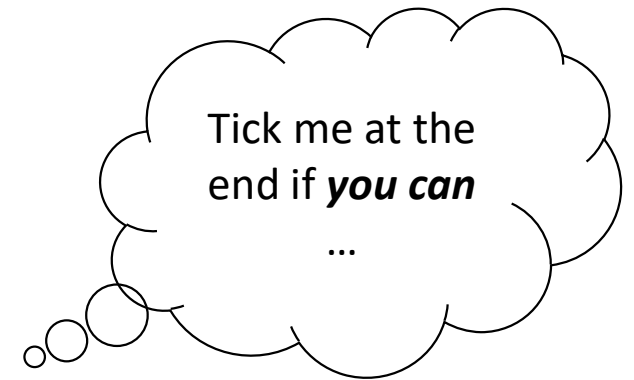

Lamps in a Series Circuit

Draw and build each of these series circuits and answer the questions

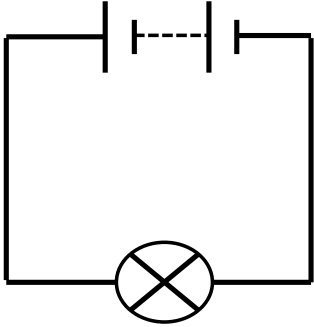
Components	Circuit Diagram
<p data-bbox="499 903 987 962">2 Cells and 1 lamp</p>	<p data-bbox="1413 703 1608 762">2 Cells</p>  <p data-bbox="1395 1153 1608 1212">1 Lamp</p>



Lamps in a Series Circuit

Draw and build each of these series circuits and answer the questions

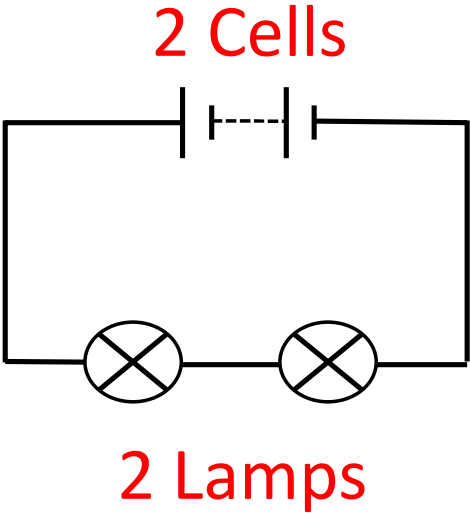
Components	Circuit Diagram
2 Cells and 2 lamps	 <p>The diagram shows a rectangular series circuit. At the top, two cells are connected in series, with the text "2 Cells" written above them in red. At the bottom, two lamps are connected in series, with the text "2 Lamps" written below them in red. The circuit is completed by vertical wires on the left and right sides.</p>



Lamps in a Series Circuit

Draw and build each of these series circuits and answer the questions

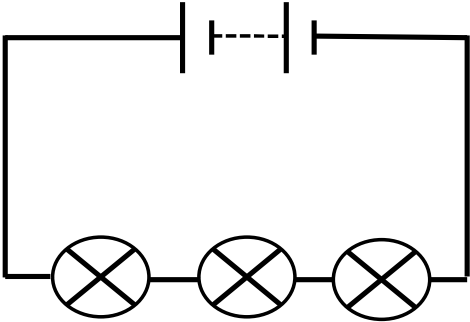
Components	Circuit Diagram
2 Cells and 3 lamps	<p data-bbox="1413 703 1608 762">2 Cells</p>  <p data-bbox="1377 1150 1630 1209">3 Lamps</p> <p>The diagram shows a rectangular series circuit. At the top, two cells are connected in series. Below them, three lamps are connected in series. The circuit is closed on the left and right sides.</p>



Lamps in a Series Circuit

1. What happens when you add more lamps to your circuit?
2. Try to explain your answer to question 1.
3. (a) What happens when you unscrew one of the bulbs?
(b) Does it matter which bulb you unscrew?
4. Try to explain your answer to question 3.



Lamps in a Series Circuit

This circuit has only ONE loop.

This is called a series circuit.

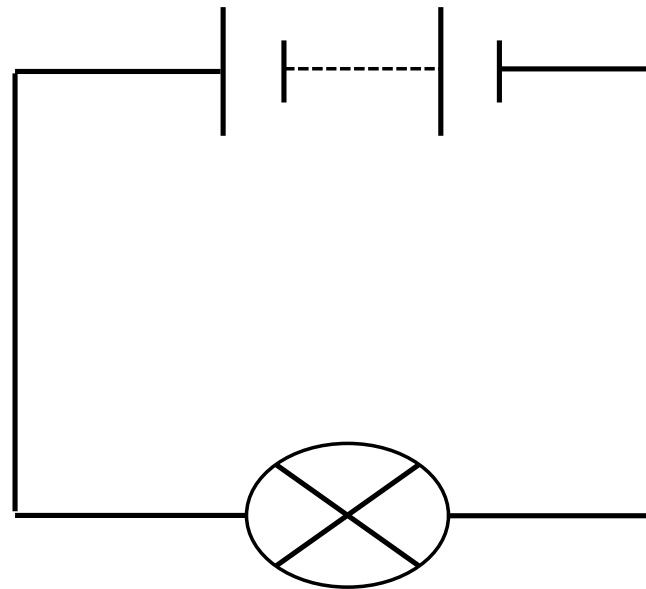

Cells (extension)

Draw each circuit, then build and answer the questions.

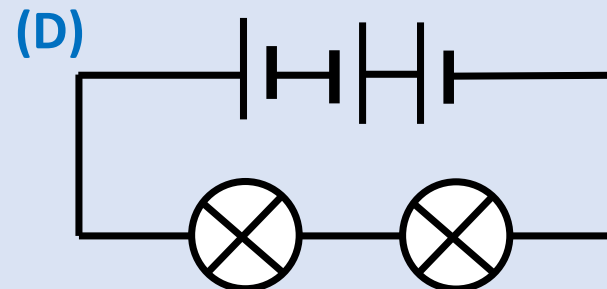
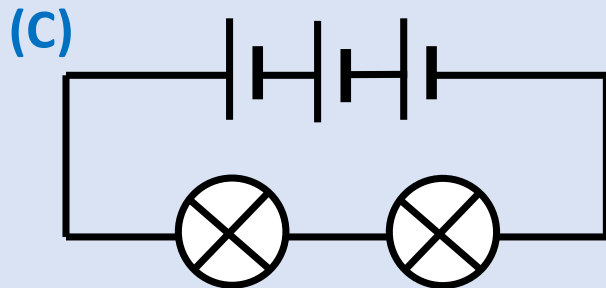
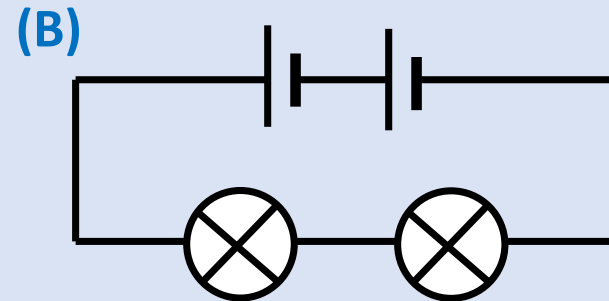
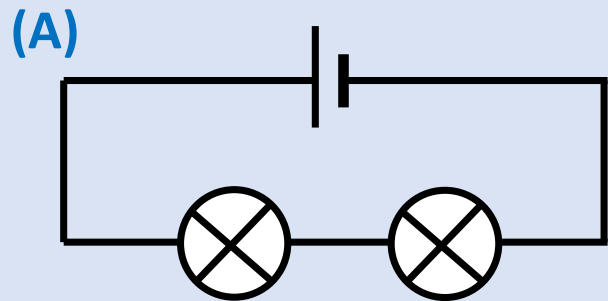

Cells (extension)

Draw each circuit, then build and answer the questions.

1. What happens to the lamps when you add more cells?
2. What happens when you turn one cell around?
3. Try to **explain** your answers to questions 1 and 2.



Series Circuits

24/09/2024

Plenary:

What do you know now about series circuits, that you did not know at the start of the lesson?

Success Criteria

- I can describe what a series circuit is.
- I can build a series circuit.

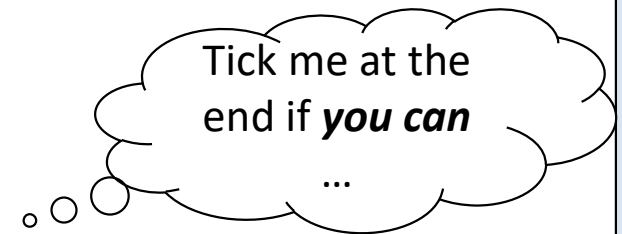

Parallel Circuits

24/09/2024

Page 13

Starter:

1. What happened to the brightness of the lamps when we added more cells to the series circuit?
2. Why?
3. What do we mean by a 'series circuit'?

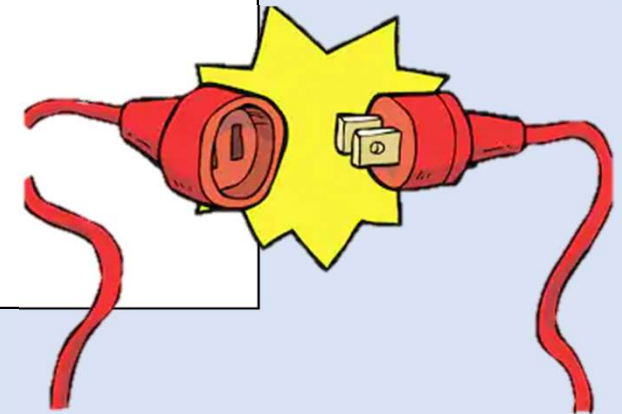

Learning Intentions:

- I am learning about parallel circuits.

Success Criteria

- I can describe the difference between a parallel and a series circuit.
- I can build a parallel circuit.

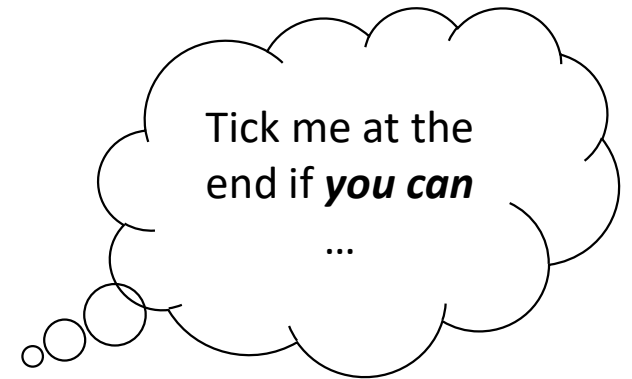

Lamps in a Parallel Circuit

Draw and build each of these parallel circuits and answer the questions

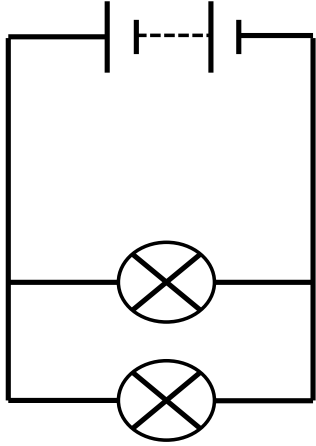
Components	Circuit Diagram
<p>2 Cells and 2 lamps</p>	<p>2 Cells</p>  <p>2 Lamps</p>



Lamps in a Parallel Circuit

Draw and build each of these Parallel circuits and answer the questions

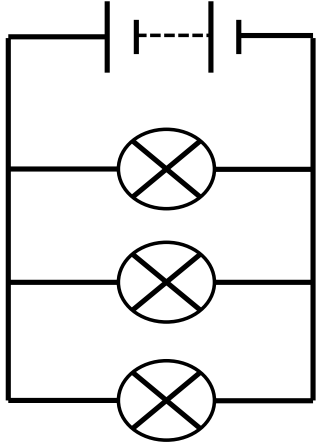
Components	Circuit Diagram
<p>2 Cells and 3 lamps</p>	<p>2 Cells</p>  <p>3 Lamps</p>



Lamps in Parallel Circuits

Draw each circuit, then build and answer the questions.

1. What happens when you add more lamps to this circuit?
2. (a) What happens when you unscrew one of the bulbs?
(b) Does it matter which bulb you unscrew?
3. Try to explain your answer to question 2.



Lamps in a Parallel Circuit

This circuit has more than one loop.
This is called a parallel circuit.

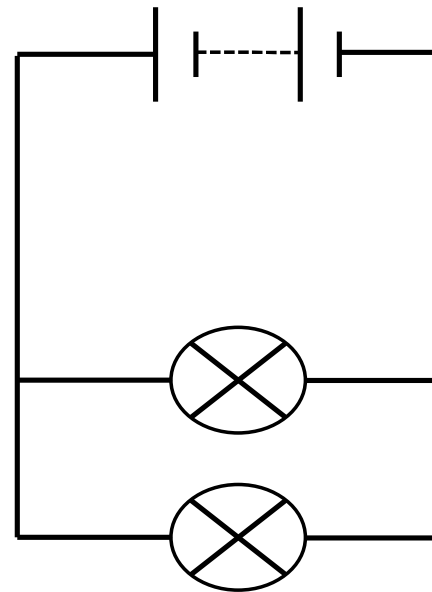

Parallel Circuits

24/09/2024

Plenary: What do you think?



Success Criteria

- I can describe the difference between a parallel and a series circuit.
- I can build a parallel circuit.

Tick me at the end if ***you can***

...

Switches in Circuits

24/09/2024

Page 15

Starter:

1. What happened when we unscrewed one of the bulbs in the parallel circuit? Explain why.
2. Describe the difference between series and parallel circuits.

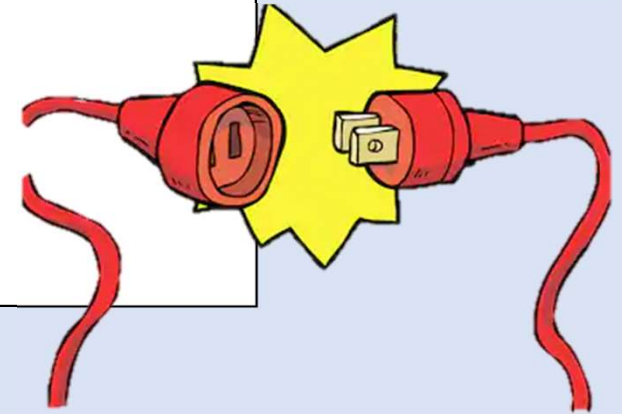
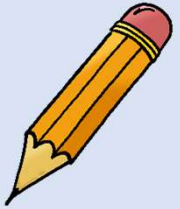

Learning Intentions:

- I am learning about switches in circuits.

Success Criteria

- I can understand switches in circuits.
- I can use circuit diagrams to build switches in circuits.

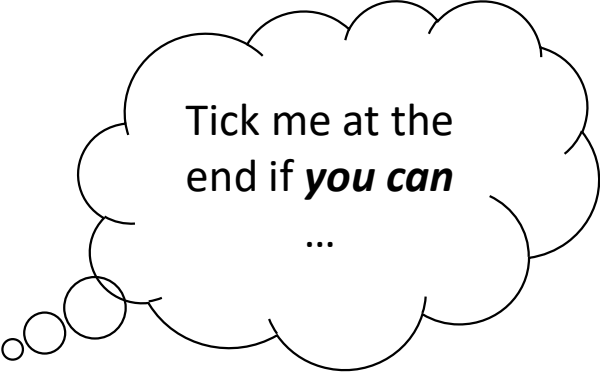

Tick me at the
end if ***you can***

...

Switches in Circuits

Draw and build each of these circuits and answer the questions

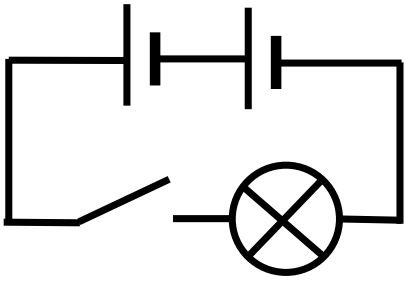
Components	Circuit Diagram
<p>2 Cells, 1 lamp, 1 switch in series</p>	<p>2 Cells</p>  <p>1 switch 1 Lamp</p>



Switches in Circuits

Draw and build each of these circuits and answer the questions

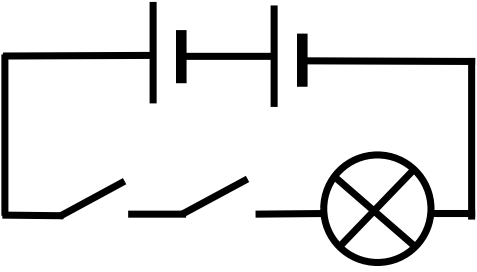
Components	Circuit Diagram
<p>2 Cells, 1 lamp, 2 switches in series</p>	<p>2 Cells</p>  <p>2 switches 1 Lamp</p>



Switches in Circuits

Draw and build each of these circuits and answer the questions

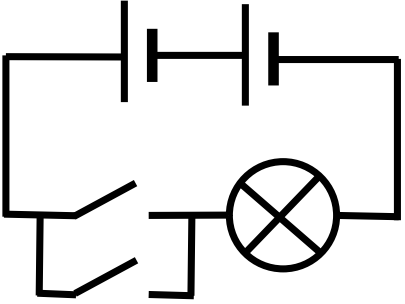
Components	Circuit Diagram
<p>2 Cells, 1 lamp, 2 switches in parallel</p>	<p>2 Cells</p>  <p>2 switches 1 Lamp</p>



Switches in Circuits

Draw each circuit, then build and answer the questions.

1. What do you have to do to light the bulb in each circuit?
2. Try to explain your answer to question 1.

3. Does it matter what “side” the switches are on? Eg:

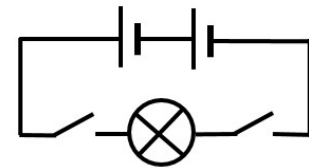

4. Give an example of a situation where you would want to use:
 - (a) two switches in series to make a device work?
 - (b) two switches in parallel to make a device work?



The Doorbell Circuit Challenge

Your task is to design a doorbell system for a person with hearing difficulties. There are three challenges below.

With your partner, talk about your challenge, and decide what you are going to do.

Each pair will:

- a) Build the working circuit
- b) Draw a circuit diagram on a sheet of A4 paper, using correct circuit symbols
- c) Describe how the circuit works (what does each component do).

The Doorbell Circuit Challenge

CHALLENGE 1

When in their living room, the person must know if the front doorbell has been pressed.

CHALLENGE 2

The house has a doorbell at the front door and the back door.

Redesign your circuit to let the person know whether the front or back doorbell is rung.

Draw the circuit diagram after your teacher checks your circuit.

Does your circuit tell you what doorbell – front or back – was rung?

CHALLENGE 3

Extend the system so that it could work in two different rooms.

Your will have to report back to the rest of the class what you have done, and how your design works.

Switches in Circuits

24/09/2024

Plenary: What is wrong with this diagram and why?

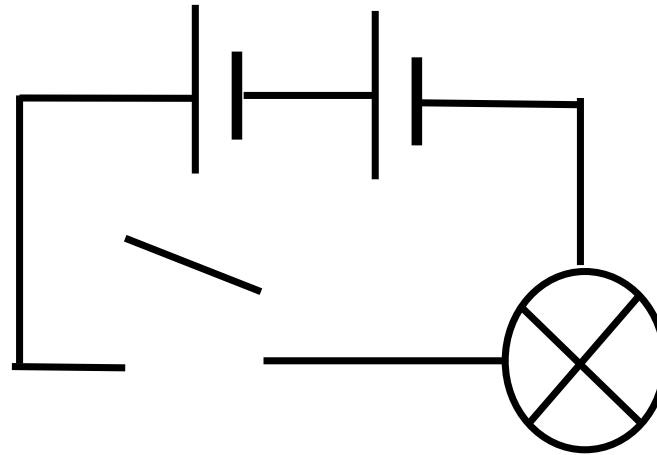

- Switch drawn incorrectly
- Lamp is placed in the corner

Describe to your neighbour what a switch does in a circuit

Success Criteria

- I can understand switches in circuits.
- I can use circuit diagrams to build circuits that use switches.

Tick me at the
end if ***you can***

...

Starter:

1. When two switches are in a series circuit, how do we make the lamp work?
2. When two switches are in parallel, how do we make the lamp work?



Learning Intentions:

- I am learning about voltage and current

Success Criteria

- I can define voltage and current
- I can state how current and voltage are measured

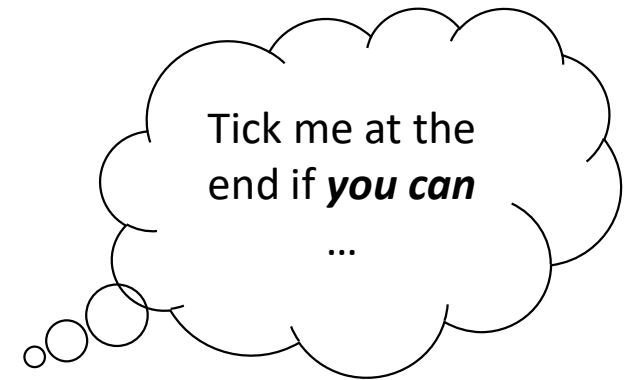

Measuring Current

Electric current is the rate of flow of electrons.

Current is measured using an ammeter.

Voltage is the electric push from a battery. It is the energy given to the charges in the circuit.

Voltage is measured using a voltmeter.



Measuring Current

Complete the diagrams:

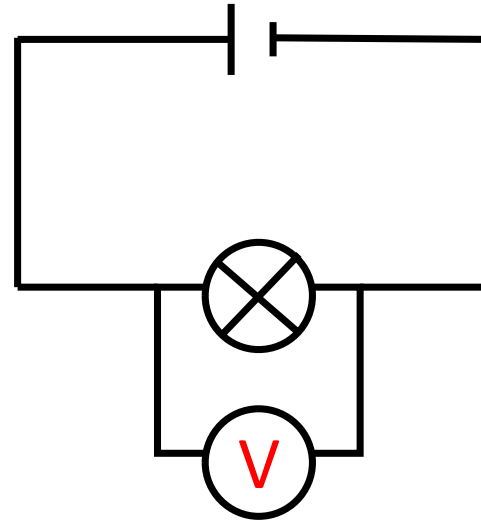
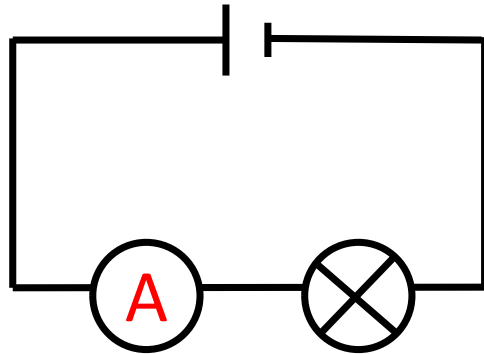

Effect of Number of Cells on Current

Aim: To investigate the effects of changing the number of cells on current in a series circuit.

Method:

1. Build a simple series circuit containing 1 cell, lamp and ammeter
2. Measure the current
3. Add a 2nd cell, measure the current. Repeat for 3 cells.



Effect of Number of Cells on Current

Method:

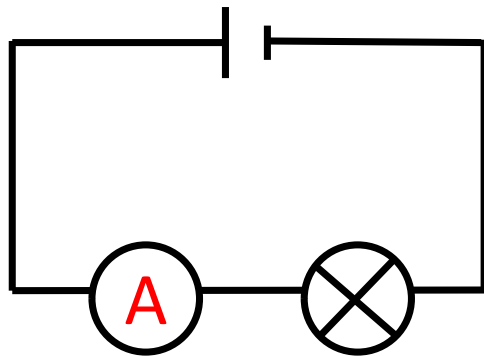

1 cell

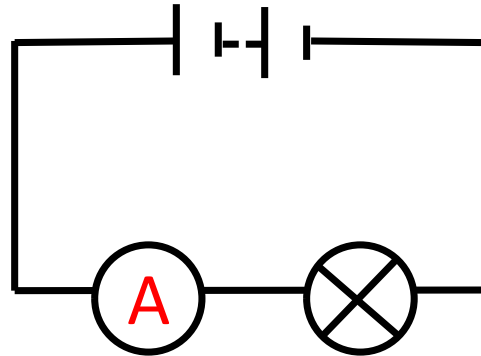

2 cells

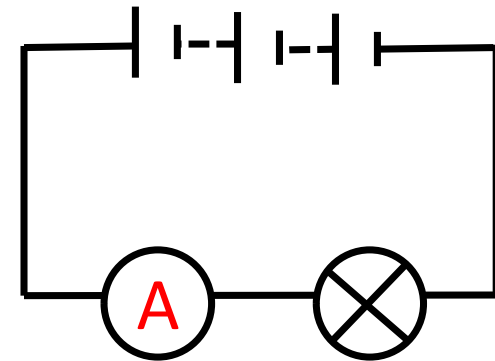

3 cells



Effect of Number of Cells on Current

Results:

Number of cells	Current (A)
1	
2	
3	



Effect of Number of Cells on Current

Conclusion: *What is the answer to your aim?*



Evaluation: *How could you improve your experiment?*

Effect of Number of Cells on Voltage

Aim: To investigate the effects of changing the number of cells on voltage.

Method:

1. Build a simple circuit containing 1 cell, lamp and voltmeter
2. Measure the voltage
3. Add a 2nd cell, measure the voltage. Repeat for 3 cells.



Effect of Number of Cells on Voltage

Method:

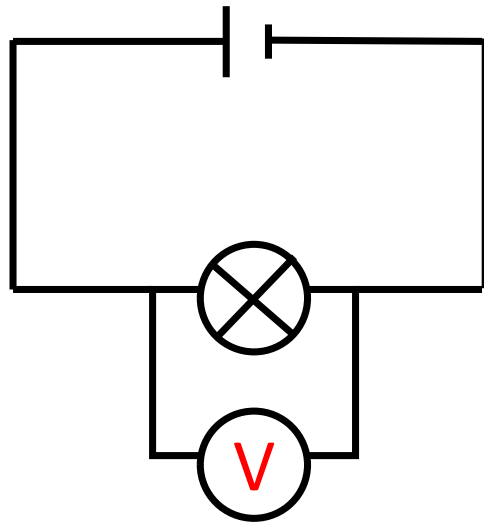

1 cell

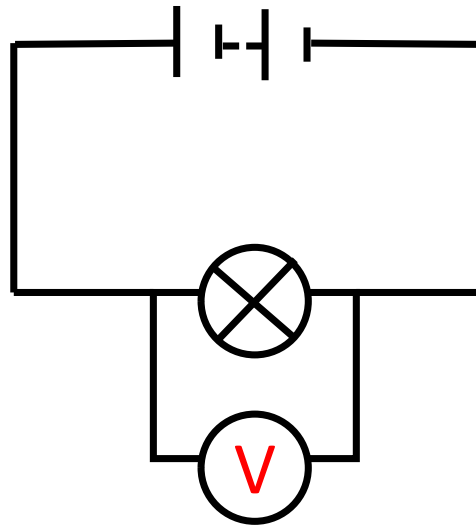

2 cells

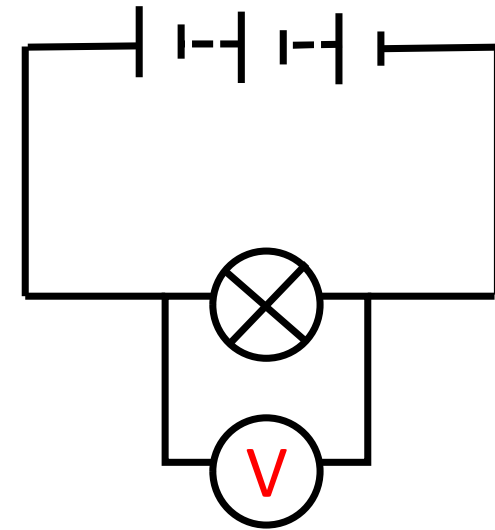

3 cells



Effect of Number of Cells on Voltage

Results:

Number of cells	Voltage (V)
1	
2	
3	



Effect of Number of Cells on Voltage

Conclusion: *What is the answer to your aim?*



Evaluation: *How could you improve your experiment?*

Measuring Voltage and Current

24/09/2024

Plenary: Which of these circuits can you use to measure the voltage of the lamp and why?

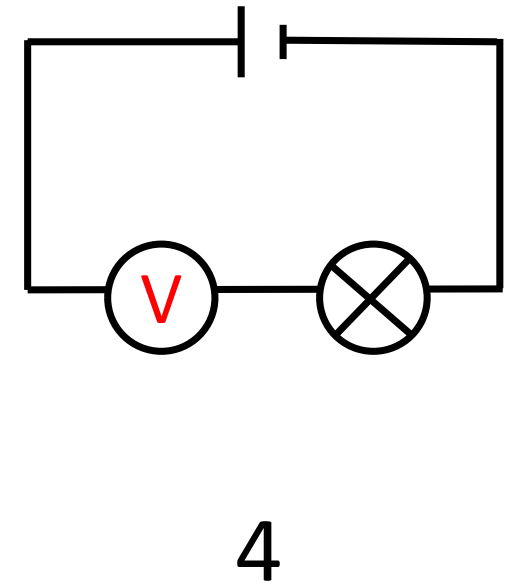
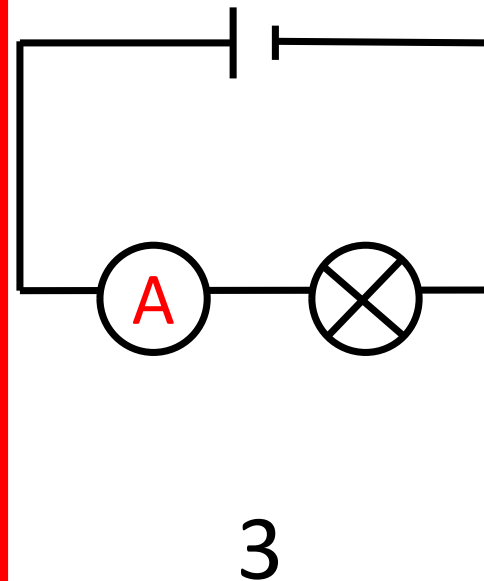
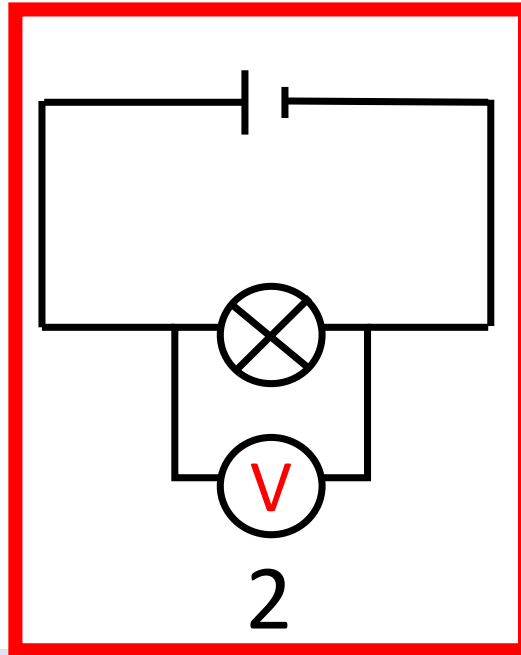
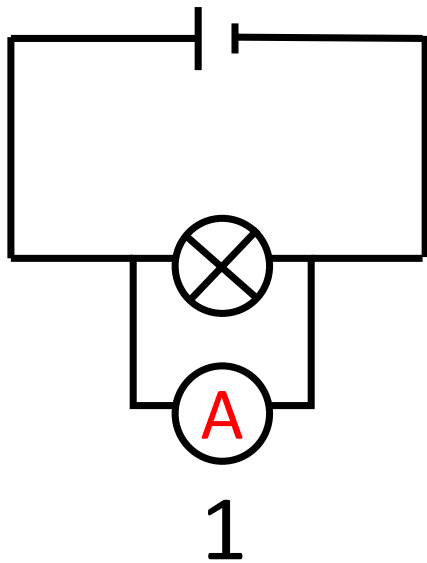

Success Criteria

- I can define voltage and current
- I can state how current and voltage are measured

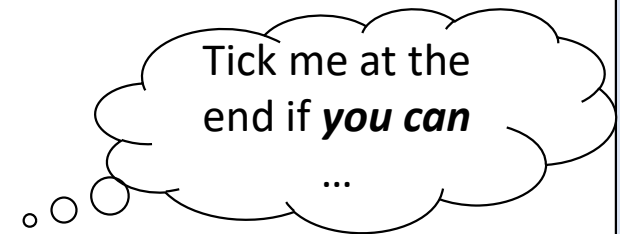

Starter:

Describe what happens to the output voltage as we increase the number of cells in a circuit.



Learning Intentions:

- I am learning about chemical cells

Success Criteria

- I can build a chemical cell
- I can investigate the effect of changing metals on output voltage.

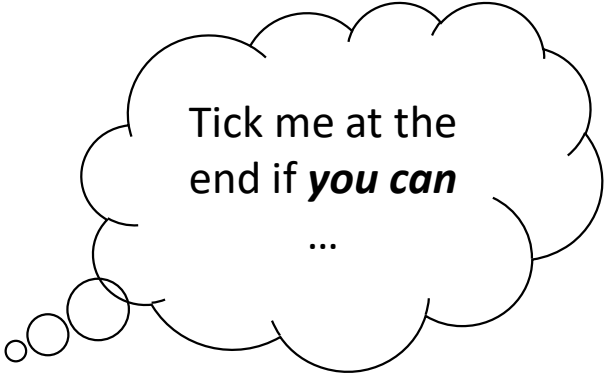

Tick me at the
end if ***you can***

...

What are Chemical Cells?

- Chemical cells use **chemical reactions** to transfer energy by **electricity**.
- Chemical cells include the familiar batteries used in torches and mobile phones.
- There are different designs of chemical cells, with different reactions depending on the type of cell.



Chemical cells produce a voltage until one of the reactants is used up. When this happens, we say the battery 'goes flat'.

Chemical Cells

A cell/battery contains chemicals which give energy. When you use a battery the chemical energy changes into electrical energy.

A simple chemical cell is made using 2 different metals (electrodes) and an electrolyte (a solution which contains charge particles which is used to complete the circuit).



Chemical Cells

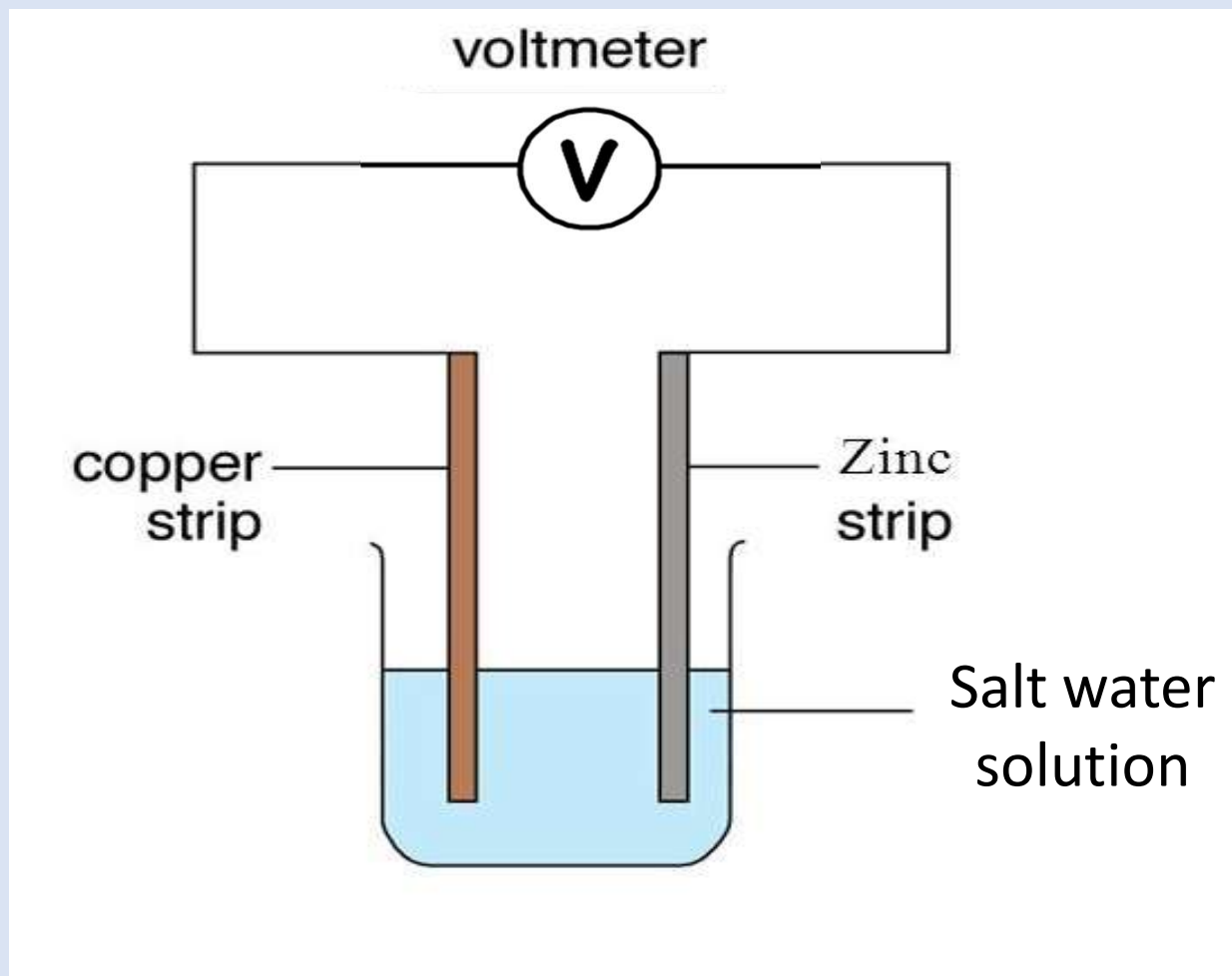

Investigating Chemical Cells

Aim: To investigate which metal electrodes produce the largest output voltage

Method:

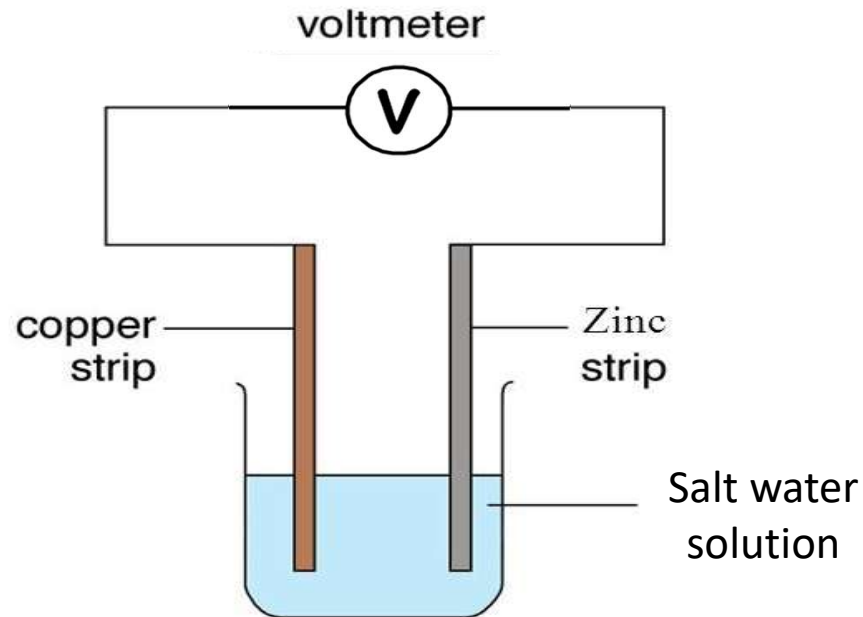

Investigating Chemical Cells

Results:

Metal	Output Voltage (V)
Magnesium	
Tin	
Aluminium	
Lead	
Nickel	



Investigating Chemical Cells

Results:

*Draw a bar graph of
your data*

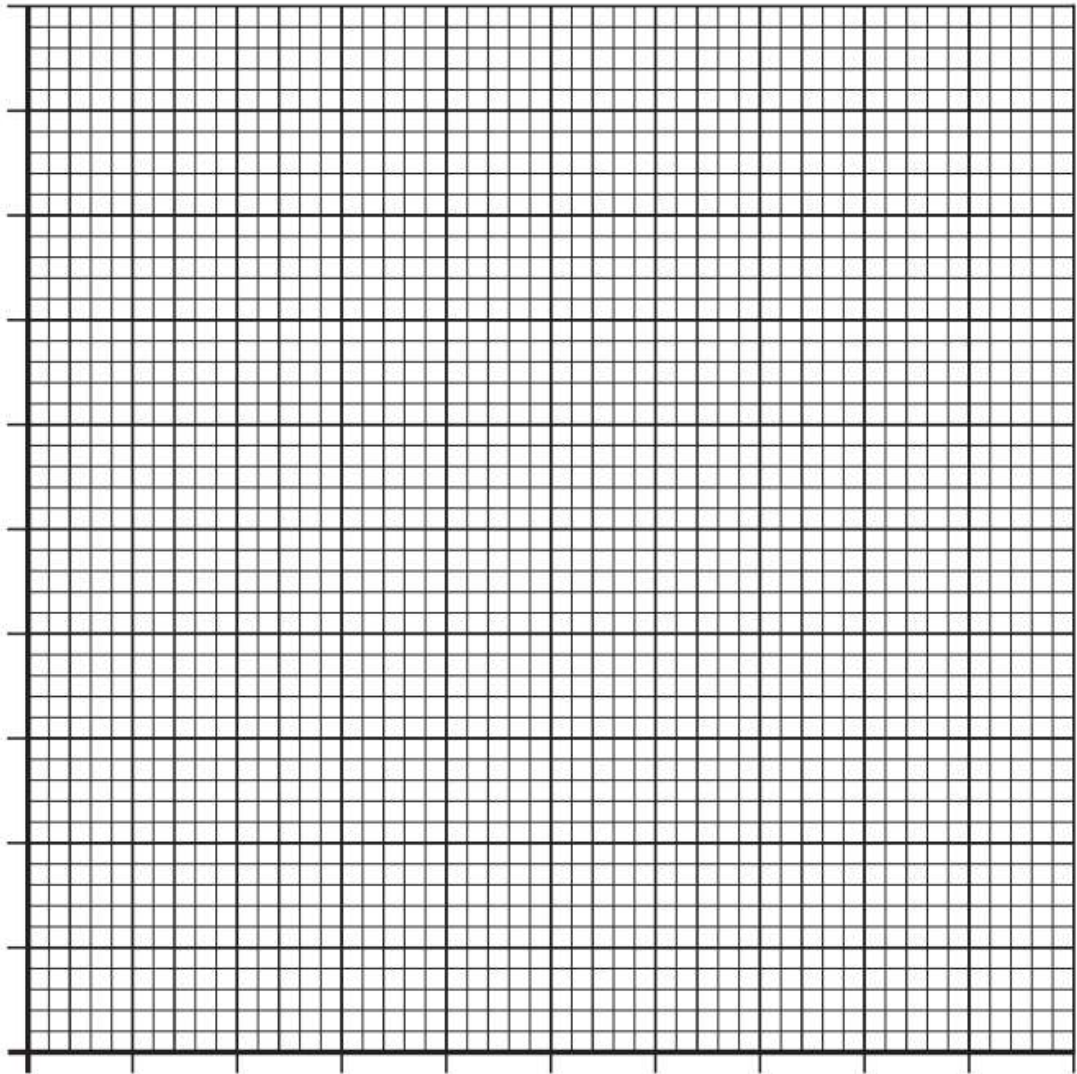

Investigating Chemical Cells

Conclusion: *What is the answer to your aim?*

Evaluation: *How could you improve your experiment?*



Chemical Cells

24/09/2024

Plenary:

I was successful when I

A question I have about today's lesson is

Today I learnt

The part of the lesson I enjoyed the most was.....

The skills I used in today's lesson were.....

One thing I need to remember from today's lesson is.....

Success Criteria

- I can build a chemical cell
- I can investigate the effect of changing metals on the output voltage.

Tick me at the end if **you can**

...

Starter:

1. In chemical cells, which type of energy is chemical energy converted into?

2. Describe what a chemical cell is made up of.



Learning Intentions:

- I am learning how to investigate fruit batteries

Success Criteria

- I can describe how to make a fruit battery
- I can complete an experiment to investigate the best fruit for making batteries

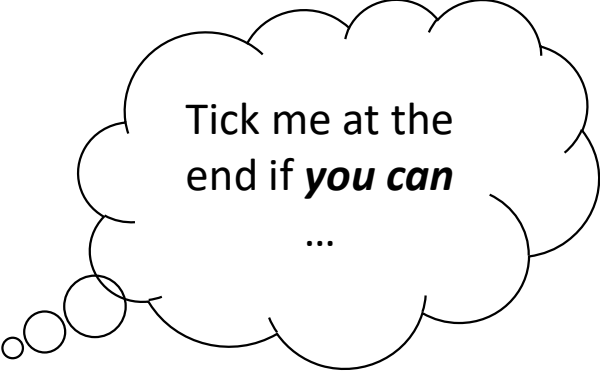

Tick me at the
end if ***you can***

...

Fruit Cell Batteries

Activity: Watch the video and note down three facts

Batteries and their impact

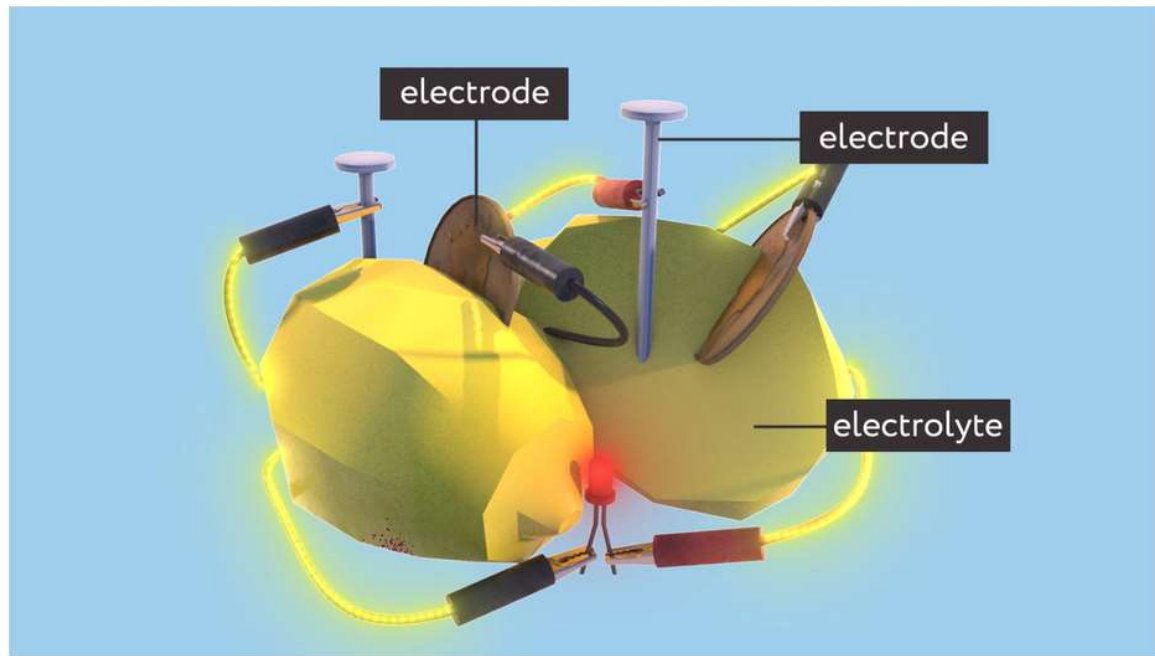

Be
prepared
to share!

<https://www.bbc.co.uk/bitesize/articles/zx4shcw#zrk3bqt>

Fruit Cell Batteries

- You could make your own lemon battery.
- Put a copper penny into the lemon, this will form the **positive electrode**, and a zinc nail for the **negative electrode**.
- These can then be attached to a light bulb or buzzer using alligator clips and wires.
- This experiment can be used to explain how a battery works. A battery requires **three things** – **two electrodes** and an **electrolyte**.

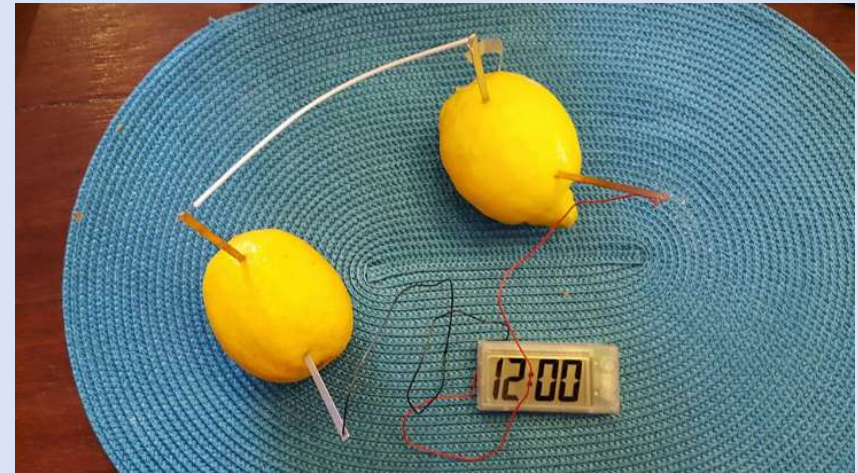

Fruit Cell Batteries

In a fruit battery, the fruit juice is the electrolyte (a liquid that conducts). This allows the electric current or charged particles called electrons flow through it to complete the circuit.

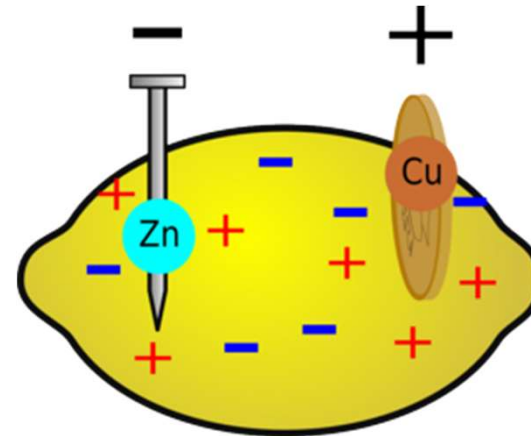

Investigating Fruit Cell Batteries

Aim: To investigate which fruit cell gives the largest output voltage



Method:

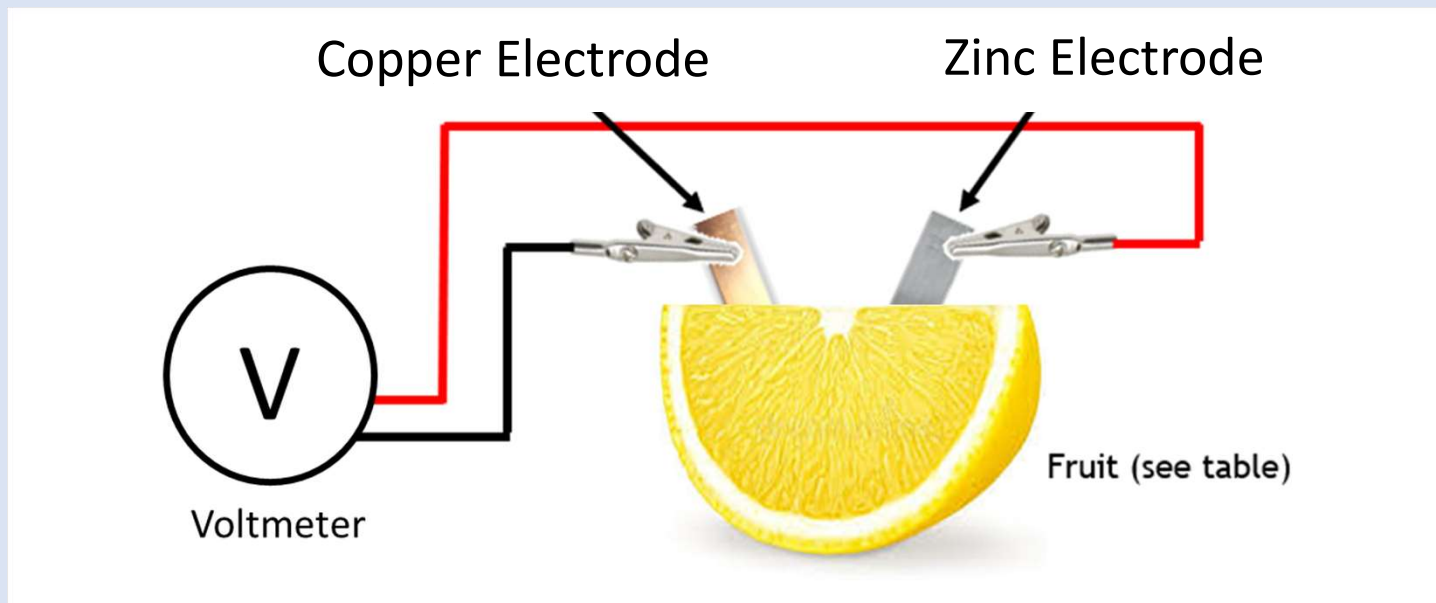

Investigating Fruit Cell Batteries



Results:

Type of Fruit	Output Voltage (V)			
	Replicate 1	Replicate 2	Replicate 3	Average
Lemon				
Orange				
Grapefruit				
Tomato				
Kiwi				

Investigating Fruit Cell Batteries

Results:

*Draw a bar graph of
your data*

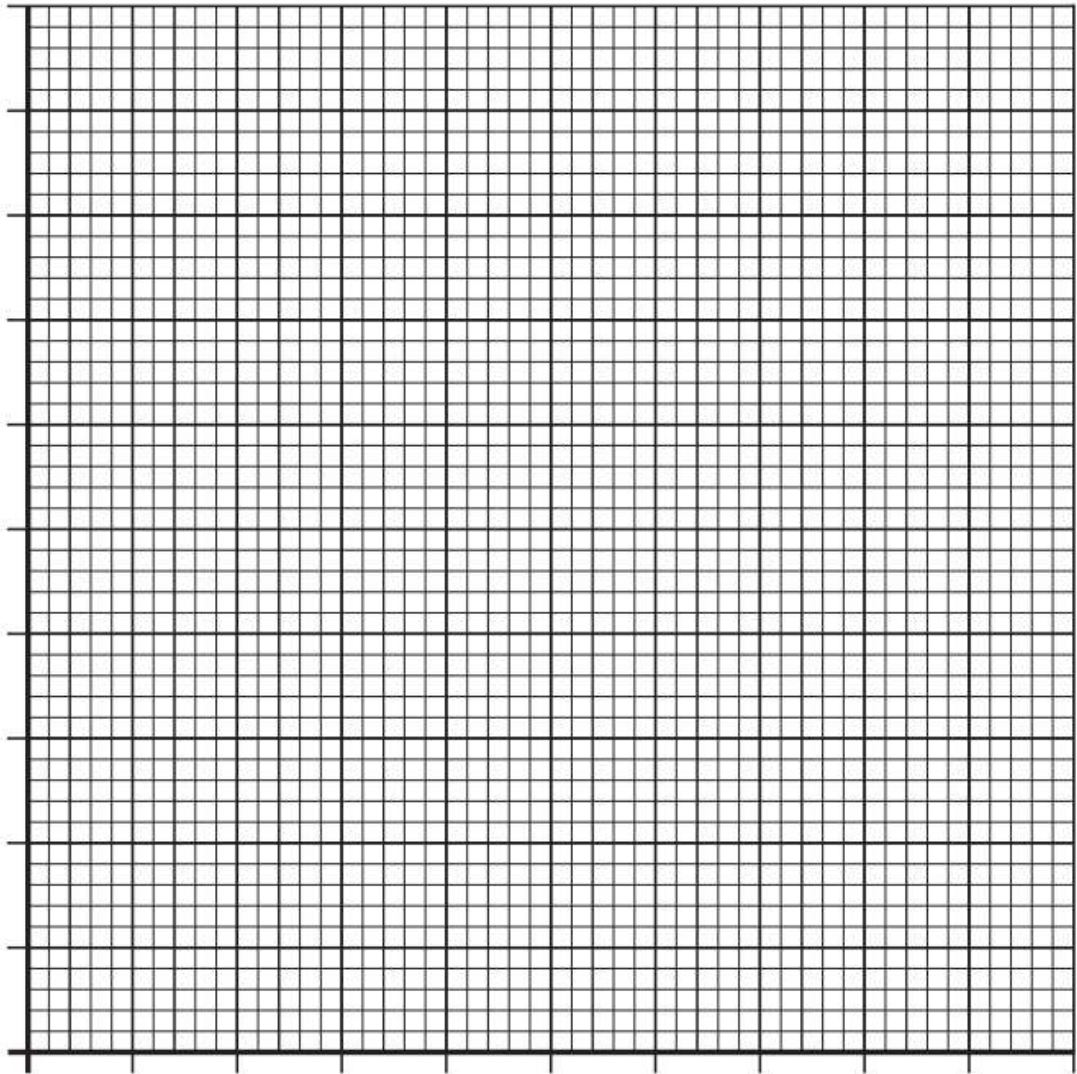

Investigating Fruit Cell Batteries

Conclusion: *What is the answer to your aim?*

Evaluation: *How could you improve your experiment?*



Investigating Fruit Cell Batteries

24/09/2024

Plenary: Which of these items do I need to make a fruit battery and measure the output voltage?



Fruit slice



Power pack



Copper electrode



Zinc electrode



Wooden electrode



Crocodile clips

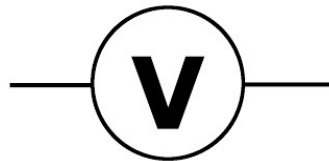

Voltmeter

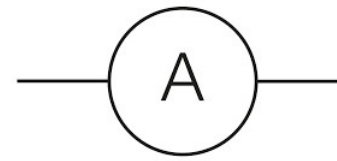

Ammeter

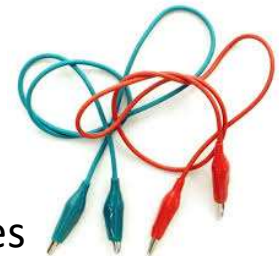

Wires

Success Criteria

- I can describe how to make a fruit battery
- I can complete an experiment to investigate the best fruit for making batteries

Tick me at the end if ***you can***

...