

# X069/201

---

NATIONAL  
QUALIFICATIONS  
2006

WEDNESDAY, 17 MAY  
1.00 PM – 3.00 PM

PHYSICS  
INTERMEDIATE 2

## Read Carefully

Reference may be made to the Physics Data Booklet

- 1 All questions should be attempted.

## Section A (questions 1 to 20)

- 2 Check that the answer sheet is for Physics Intermediate 2 (Section A).
- 3 For this section of the examination you must use an **HB pencil** and, where necessary, an eraser.
- 4 Check that the answer sheet you have been given has **your name, date of birth, SCN** (Scottish Candidate Number) and **Centre Name** printed on it.  
Do not change any of these details.
- 5 If any of this information is wrong, tell the Invigilator immediately.
- 6 If this information is correct, **print** your name and seat number in the boxes provided.
- 7 There is **only one correct** answer to each question.
- 8 Any rough working should be done on the question paper or the rough working sheet, **not** on your answer sheet.
- 9 At the end of the exam, put the **answer sheet for Section A inside the front cover of your answer book.**
- 10 Instructions as to how to record your answers to questions 1–20 are given on page three.

## Section B (questions 21 to 31)

- 11 Answer the questions numbered 21 to 31 in the answer book provided.
- 12 **All answers must be written clearly and legibly in ink.**
- 13 Fill in the details on the front of the answer book.
- 14 Enter the question number clearly in the margin of the answer book beside each of your answers to questions 21 to 31.
- 15 Care should be taken to give an appropriate number of significant figures in the final answers to calculations.



## DATA SHEET

### *Speed of light in materials*

<i>Material</i>	<i>Speed in m/s</i>
Air	$3.0 \times 10^8$
Carbon dioxide	$3.0 \times 10^8$
Diamond	$1.2 \times 10^8$
Glass	$2.0 \times 10^8$
Glycerol	$2.1 \times 10^8$
Water	$2.3 \times 10^8$

### *Speed of sound in materials*

<i>Material</i>	<i>Speed in m/s</i>
Aluminium	5200
Air	340
Bone	4100
Carbon dioxide	270
Glycerol	1900
Muscle	1600
Steel	5200
Tissue	1500
Water	1500

### *Gravitational field strengths*

	<i>Gravitational field strength on the surface in N/kg</i>
Earth	10
Jupiter	26
Mars	4
Mercury	4
Moon	1.6
Neptune	12
Saturn	11
Sun	270
Venus	9

### *Specific heat capacity of materials*

<i>Material</i>	<i>Specific heat capacity in J/kg °C</i>
Alcohol	2350
Aluminium	902
Copper	386
Glass	500
Ice	2100
Iron	480
Lead	128
Oil	2130
Water	4180

### *Specific latent heat of fusion of materials*

<i>Material</i>	<i>Specific latent heat of fusion in J/kg</i>
Alcohol	$0.99 \times 10^5$
Aluminium	$3.95 \times 10^5$
Carbon dioxide	$1.80 \times 10^5$
Copper	$2.05 \times 10^5$
Iron	$2.67 \times 10^5$
Lead	$0.25 \times 10^5$
Water	$3.34 \times 10^5$

### *Melting and boiling points of materials*

<i>Material</i>	<i>Melting point in °C</i>	<i>Boiling point in °C</i>
Alcohol	-98	65
Aluminium	660	2470
Copper	1077	2567
Glycerol	18	290
Lead	328	1737
Iron	1537	2747

### *Specific latent heat of vaporisation of materials*

<i>Material</i>	<i>Specific latent heat of vaporisation in J/kg</i>
Alcohol	$11.2 \times 10^5$
Carbon dioxide	$3.77 \times 10^5$
Glycerol	$8.30 \times 10^5$
Turpentine	$2.90 \times 10^5$
Water	$22.6 \times 10^5$

### *Radiation weighting factors*

<i>Type of radiation</i>	<i>Radiation weighting factor</i>
alpha	20
beta	1
fast neutrons	10
gamma	1
slow neutrons	3

## SECTION A

For questions 1 to 20 in this section of the paper the answer to each question is either A, B, C, D or E. Decide what your answer is, then, using your pencil, put a horizontal line in the space provided—see the example below.

### EXAMPLE

The energy unit measured by the electricity meter in your home is the

- A kilowatt-hour
- B ampere
- C watt
- D coulomb
- E volt.

The correct answer is **A**—kilowatt-hour. The answer **A** has been clearly marked in **pencil** with a horizontal line (see below).

 **A**   **B**   **C**   **D**   **E**  
=   =   =   =   =

### Changing an answer

If you decide to change your answer, carefully erase your first answer and, using your pencil, fill in the answer you want. The answer below has been changed to **E**.

**A**   **B**   **C**   **D**   **E**   
=   =   =   =   =

[Turn over

## SECTION A

Answer questions 1–20 on the answer sheet.

1. A car travels with an initial speed of 10 m/s. It now accelerates steadily to 30 m/s in 5 s.

Which row shows the car's acceleration and average speed during this time?

	<i>Acceleration</i> (m/s <sup>2</sup> )	<i>Average Speed</i> (m/s)
A	2	10
B	2	20
C	4	20
D	4	30
E	8	30

2. Which of these physical quantities are equivalent?

- A Mass *and* weight
- B Mass *and* acceleration due to gravity
- C Weight *and* acceleration due to gravity
- D Weight *and* gravitational field strength
- E Acceleration due to gravity *and* gravitational field strength

3. A space vehicle of mass 120 kg is falling vertically towards a planet. The gravitational field strength at this point is 3.5 N/kg.

The vehicle fires a rocket engine which applies a steady upward force of 660 N to the vehicle.

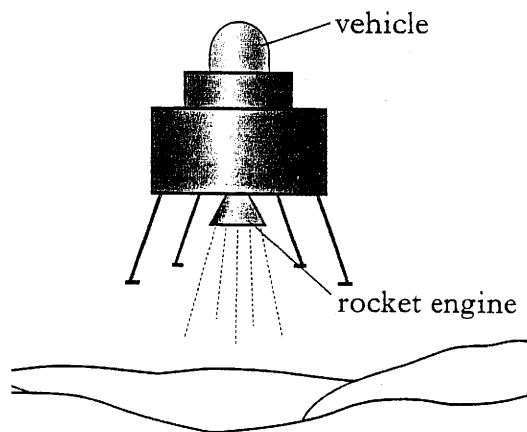

Initially the vehicle will

- A move towards the surface, accelerating
- B move towards the surface at steady speed
- C move towards the surface, decelerating
- D move away from the surface, accelerating
- E move away from the surface at steady speed.

4. A person sits on a chair which rests on the Earth. The person exerts a downward force on the chair.

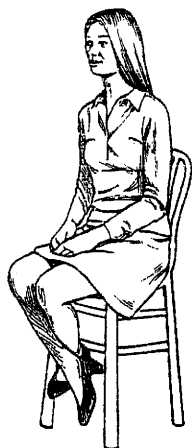

Which of the following is the reaction to this force?

- A The force of the person on the Earth  
 B The force of the person on the chair  
 C The force of the Earth on the person  
 D The force of the chair on the Earth  
 E The force of the chair on the person
5. An electric motor raises a lift of mass 288 kg through a height of 15 m. The input energy to the motor is 54 000 J. The percentage efficiency of the motor is given by

- A  $\frac{288 \times 15 \times 10}{54\,000}$   
 B  $\frac{54\,000 \times 10}{288 \times 15 \times 100}$   
 C  $\frac{288 \times 15 \times 100}{54\,000}$   
 D  $\frac{288 \times 15 \times 10 \times 100}{54\,000}$   
 E  $\frac{54\,000 \times 100}{288 \times 10 \times 15}$

6. A solid substance is placed in an insulated container and heated. The graph shows how the temperature of the substance varies with time.

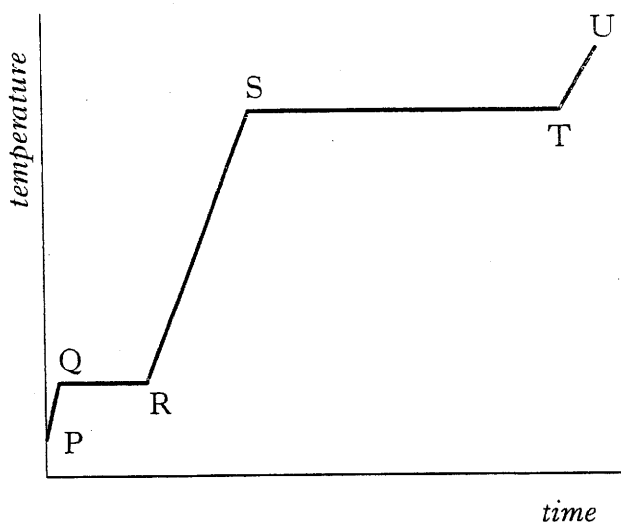

To calculate the specific latent heat of fusion of the substance, a student would use the time from section

- A PQ  
 B QR  
 C RS  
 D ST  
 E TU.
7. Which of the following statements is/are correct?
- I The voltage of a battery is the number of joules of energy it gives to each coulomb of charge.  
 II A battery only has a voltage when it is connected in a complete circuit.  
 III Electrons are free to move within an insulator.
- A I only  
 B II only  
 C III only  
 D II and III only  
 E I, II and III

[Turn over

8. A student suspects that ammeter  $A_1$  may be inaccurate. Ammeter  $A_2$  is known to be accurate.

Which of the following circuits should be used to compare  $A_1$  with  $A_2$ ?

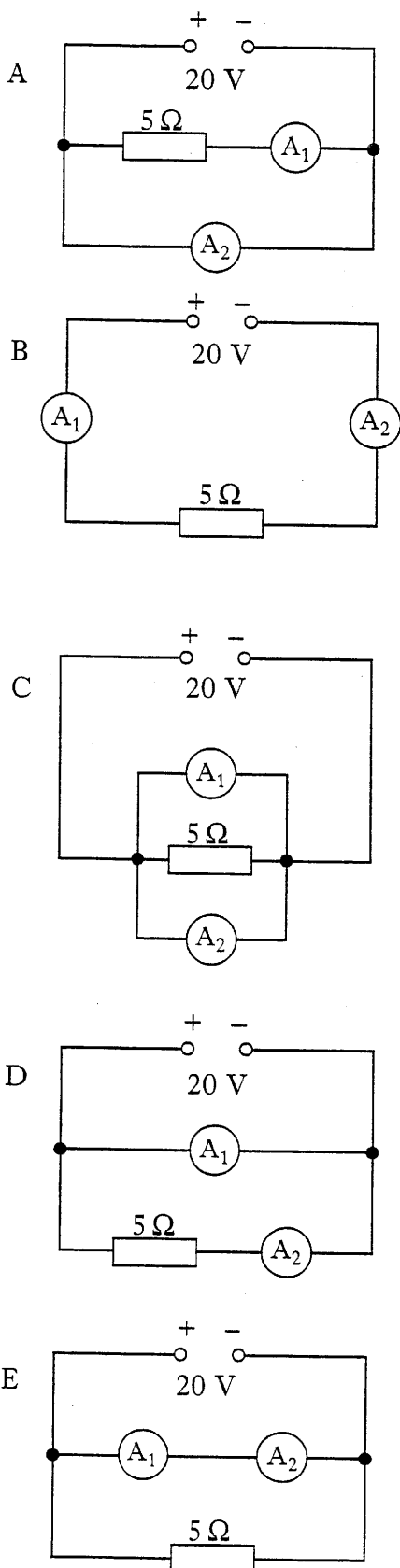

9. A circuit is set up as shown.

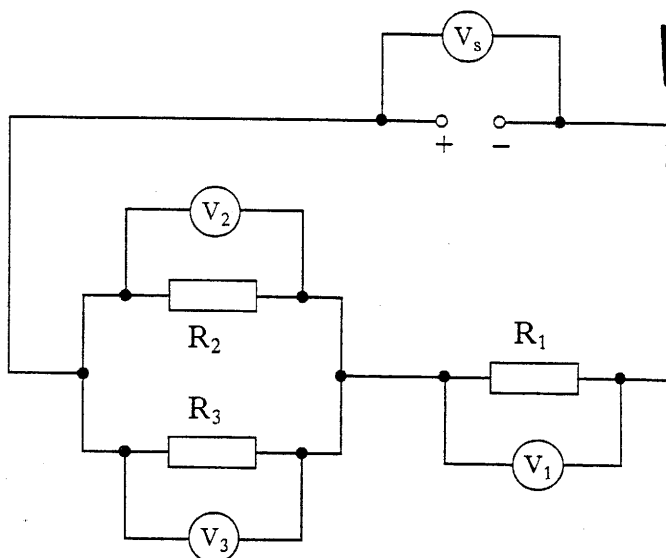

Which of the following statements about the readings on the voltmeters **must always** be true?

- I  $V_1 = V_2$   
 II  $V_2 = V_3$   
 III  $V_s = V_1 + V_2$
- A II only  
 B I and II only  
 C I and III only  
 D II and III only  
 E I, II and III

10. Three resistors are connected as shown.

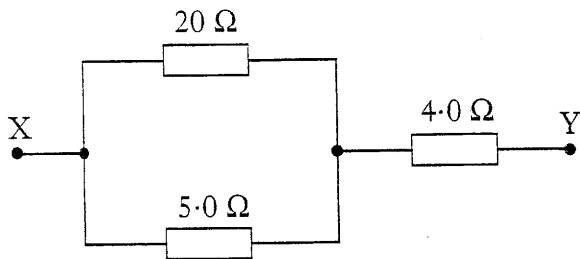

The resistance between X and Y is

- A 0.5 Ω  
 B 2.0 Ω  
 C 4.25 Ω  
 D 8.0 Ω  
 E 29 Ω.
11. A battery is connected in series to a lamp and resistor as shown.

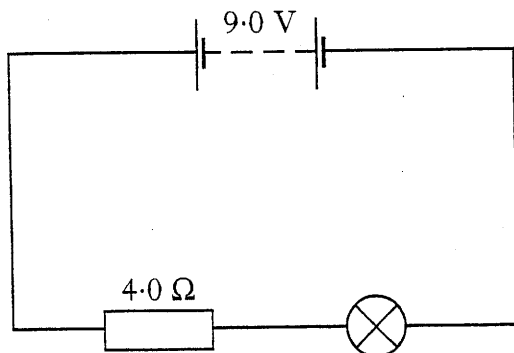

The current in the lamp is 1.5 A.

The power developed in the lamp is

- A 3.0 W  
 B 4.5 W  
 C 6.0 W  
 D 9.0 W  
 E 13.5 W.

12. A student investigates the effect of moving a magnet into and out of a coil.

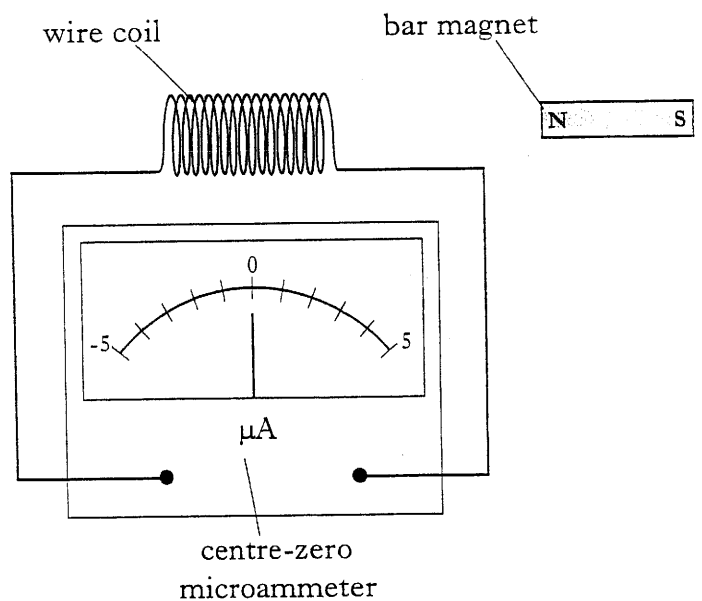

Which of the following statements is/are correct?

- I When the magnet is moving into the coil, the meter shows a current.  
 II The greatest current is measured when the magnet is stationary inside the coil.  
 III When the magnet is moving out of the coil, the meter shows no current.

- A I only  
 B II only  
 C I and II only  
 D II and III only  
 E I, II and III

[Turn over

13. A light-emitting diode (LED) is used to show that a car windscreen heater is switched on.

The supply voltage is 14.5 V. The current through the LED is 5.0 mA, when the potential difference across it is 2.3 V.

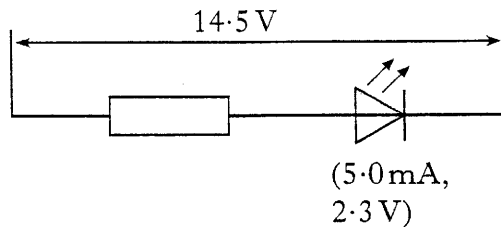

The resistance of the series resistor is

- A 0.46  $\Omega$   
 B 2.90  $\Omega$   
 C 460  $\Omega$   
 D 2440  $\Omega$   
 E 2900  $\Omega$ .
14. An amplifier has a voltage gain of 500. A signal of voltage 3.6 mV and frequency 256 Hz is applied to the input of the amplifier.

Which row shows the voltage and frequency of the signal at the amplifier output?

	Voltage	Frequency
A	7.2 $\mu$ V	256 Hz
B	3.6 mV	128 kHz
C	1.8 V	256 Hz
D	1.8 V	128 kHz
E	1800 V	256 Hz

15. A beam of light has a wavelength of  $4.80 \times 10^{-7}$  m in air. The frequency of this light is

- A  $1.60 \times 10^{-15}$  Hz  
 B  $2.40 \times 10^{-15}$  Hz  
 C  $7.08 \times 10^8$  Hz  
 D  $4.17 \times 10^{14}$  Hz  
 E  $6.25 \times 10^{14}$  Hz.

16. Which of the following statements is/are correct?

- I A long sighted person cannot focus sharply on near objects.  
 II In a short sighted person's eye, rays from a distant object focus behind the retina.  
 III As lens power increases, the focal length decreases.

- A I only  
 B I and II only  
 C I and III only  
 D II and III only  
 E I, II and III

17. A student is asked to write down some types of electromagnetic waves in order of increasing wavelength. The student's answer is **not** correct.

X-rays	Ultraviolet	Infrared	Visible light	Microwaves
--------	-------------	----------	---------------	------------

Which **two** of these should be exchanged to make the student's answer correct?

- A X-rays and infrared  
 B Visible light and infrared  
 C Infrared and ultraviolet  
 D Infrared and microwaves  
 E X-rays and microwaves



18. Below are three statements about radiation.

- I The half life of a radioactive source is half of the time it takes for its activity to reduce to zero.
- II The activity of a radioactive source is the number of decays per minute.
- III The risk of harm from radiation is not the same for all types of tissue.

Which statement or statements is/are true?

- A I only
- B II only
- C III only
- D II and III only
- E I, II and III

19. A worker in a nuclear power station is accidentally exposed to 3.0 mGy of gamma radiation and 0.50 mGy of fast neutrons.

The radiation weighting factor for gamma radiation is 1 and for fast neutrons is 10.

The total equivalent dose received by the worker, in mSv, is

- A 3.50
- B 8.00
- C 11.0
- D 35.0
- E 38.5.

20. The diagram shows a nuclear reactor in a power station.

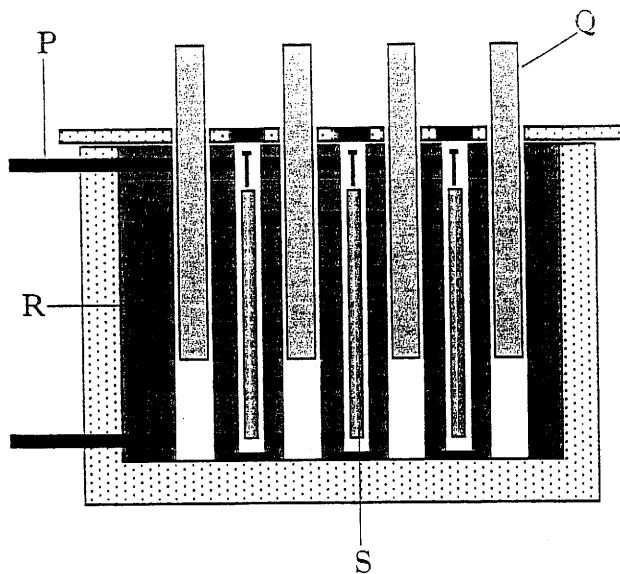

Which row shows the parts of the reactor?

	P	Q	R	S
A	moderator	fuel rod	coolant	control rod
B	control rod	moderator	coolant	fuel rod
C	moderator	control rod	coolant	fuel rod
D	coolant	control rod	moderator	fuel rod
E	coolant	fuel rod	moderator	control rod

[Turn over

[BLANK PAGE]

Write your answers to questions 21–31 in the answer book.

All answers must be written clearly and legibly in ink.

21. In a mountain-bike competition, a competitor starts from rest at the top of a hill. He pedals downhill and after 2.5 s he passes point X which is 3 m lower than the start. The total mass of the bike and competitor is 90 kg.

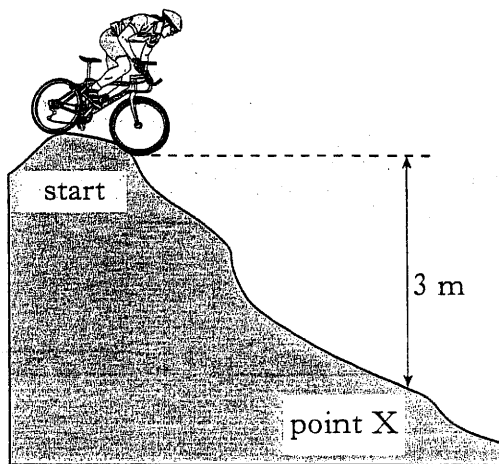

A speed time graph for this part of the competitor's journey is shown below.

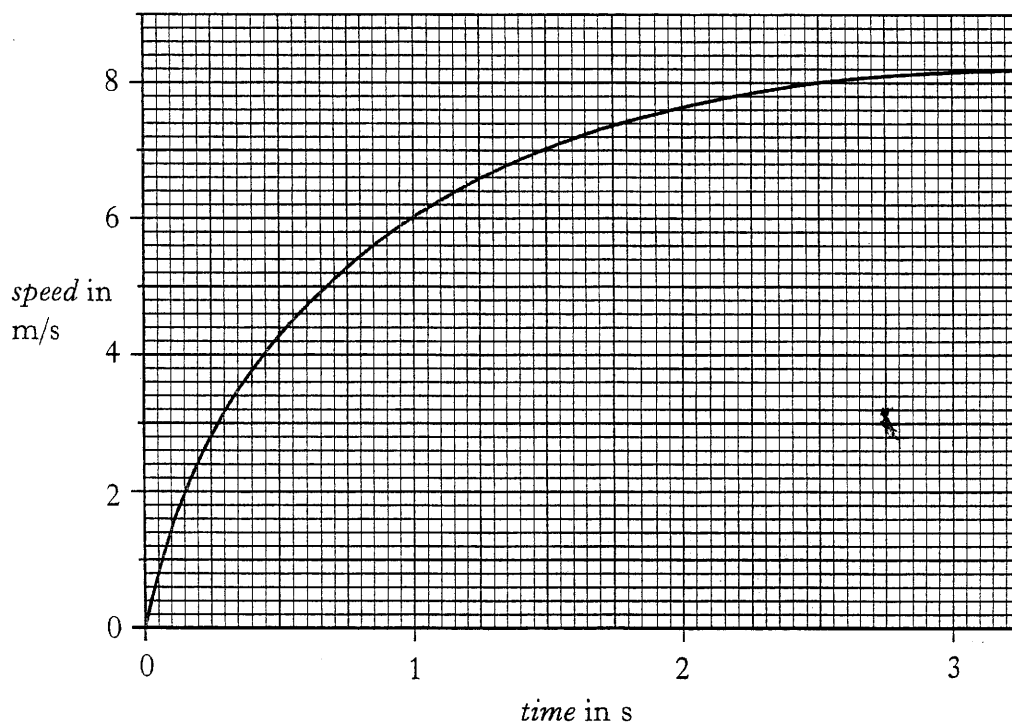

- (a) Calculate the decrease in gravitational potential energy of the competitor and bike between the start and point X. 2
- (b) Calculate the kinetic energy of the competitor and bike at point X. 2
- (c) Explain the difference between your answers to (a) and (b). 2
- (d) (i) What happens to the acceleration of the competitor during the first 2.5 s? 1
- (ii) Explain, in terms of forces, why this happens. 1

(8)

22. A fully laden oil tanker of mass  $7.5 \times 10^8$  kg leaves a loading terminal.

Its engine and propellers produce a forward force of  $6.0 \times 10^6$  N. A tugboat pushes against one side of the tanker as shown. The tug applies a pushing force of  $8.0 \times 10^6$  N.

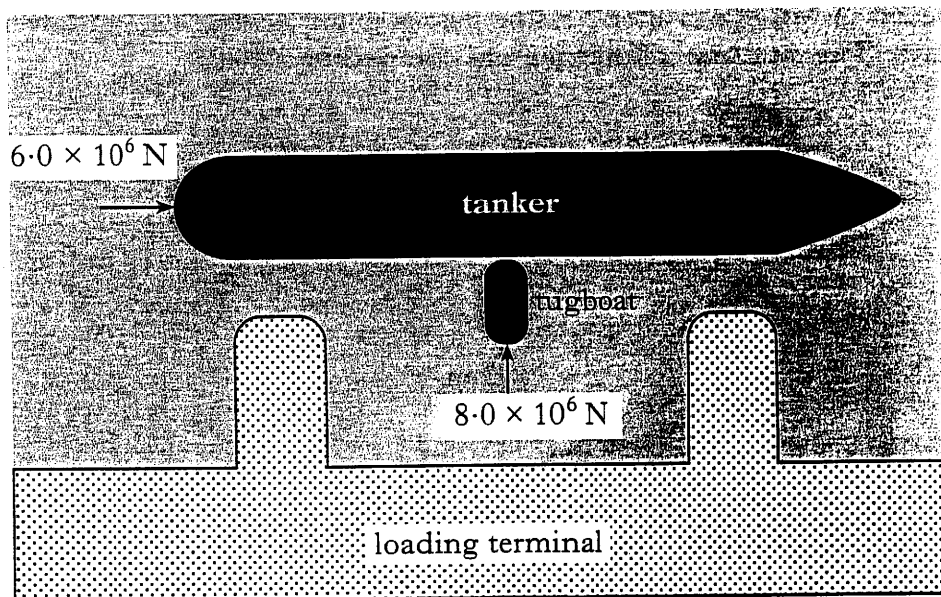

- (a) Using a scale diagram or otherwise, find the size of the resultant of these two forces. 2
- (b) Calculate the initial acceleration of the tanker. 2
- (c) Out in the open sea, the side of the tanker is struck by a wave once every 16 s. The speed of the waves is 12.5 m/s.

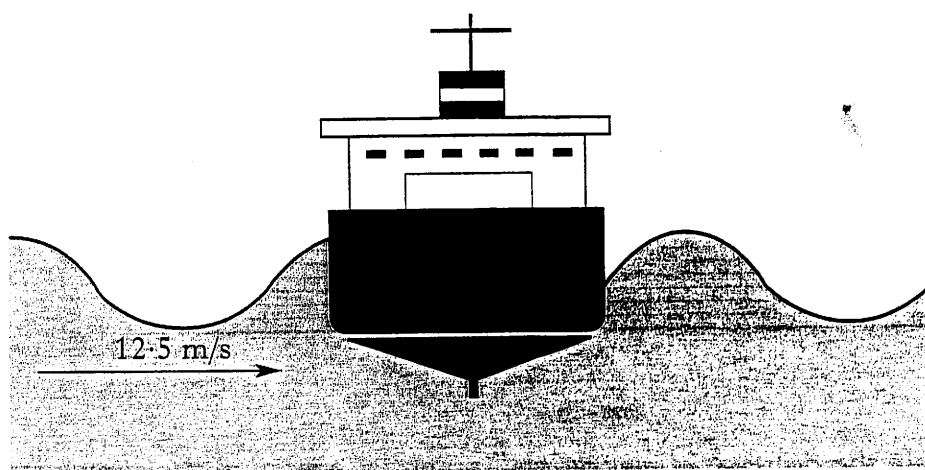

For these waves, calculate:

- (i) the frequency;
- (ii) the wavelength.

1  
2  
(7)

23. In a circus trapeze act, gymnast A has a mass of 60 kg. Gymnast B has a mass of 50 kg.

Gymnast A swings down on the trapeze and collides with gymnast B. They move off together at 4.8 m/s.

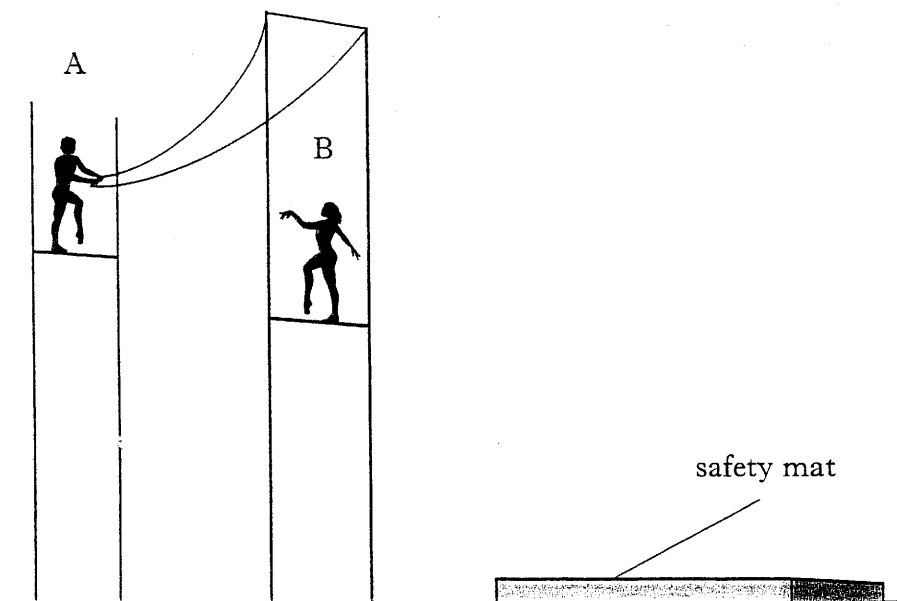

- (a) Calculate the total momentum of the two gymnasts just after the collision. 2
- (b) Calculate the speed of gymnast A just before the collision. 2
- (c) At the point of collision, gymnast A lets go of the trapeze. At this instant, the pair are travelling horizontally. They fall together for 0.65 s until they land on a safety mat.
- (i) Calculate the horizontal distance they travel until they reach the mat. 2
- (ii) Calculate the **vertical** speed with which they strike the mat. 2
- (8)

[Turn over

24. A blacksmith cools a hot iron horse-shoe of mass 0.75 kg by dropping it into water. The mass of the water is 15 kg and its initial temperature is  $17^{\circ}\text{C}$ . Heat energy from the iron warms the water until both iron and water are at  $23^{\circ}\text{C}$ .

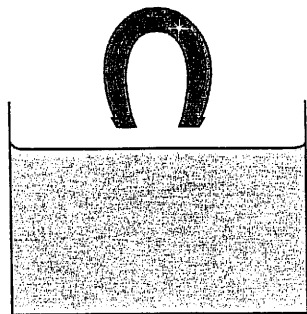

Data on page two will be required for this question.

- (a) Calculate the heat energy absorbed by the water. 2
- (b) Calculate the initial temperature of the horse-shoe. 3
- (c) State **one** assumption required for the calculation in part (b). 1
- (d) What would happen to the temperature rise of the liquid if the blacksmith had replaced the water with the same mass of oil? You **must** explain your answer. 2
- (8)

25. An electric locomotive pulls a car shuttle train through the Channel Tunnel. The maximum power of the locomotive is 7.0 MW.

Current is supplied to the locomotive through an overhead wire at a voltage of 25 kV. A transformer reduces this voltage to 2.0 kV to operate the electric motors. A simplified diagram below shows the circuit.

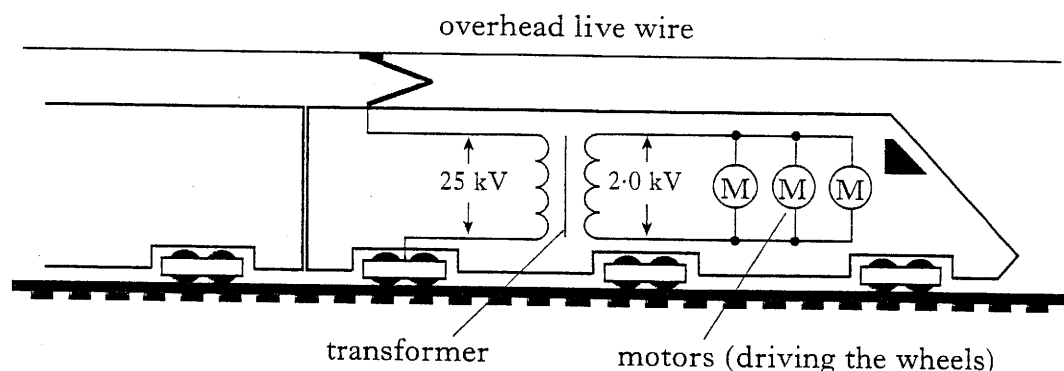

- (a) The secondary coil of the transformer has 400 turns. Calculate the number of turns on the primary coil. 2
- (b) Calculate the current in the secondary coil when the locomotive is at maximum power. 2
- (c) Over part of the journey the train travels at a steady speed. It covers a distance of 540 m in a time of 15 s.

Calculate the maximum pulling force of the locomotive over this part of the journey. 3

(7)

[Turn over

26. (a) Explain the difference between direct current (d.c.) and alternating current (a.c.) in terms of the movement of charges in a conductor.
- (b) A student investigates voltages in the following a.c. circuit, using two oscilloscopes connected as shown.

2

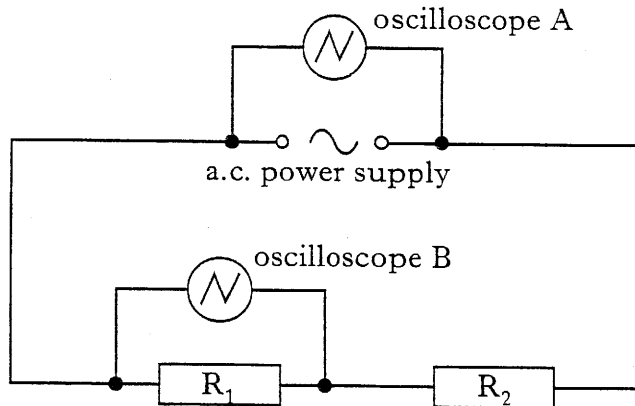

On oscilloscope A, the voltage scale is set at 5 V/cm.

On oscilloscope B, the voltage scale is set at 2 V/cm.

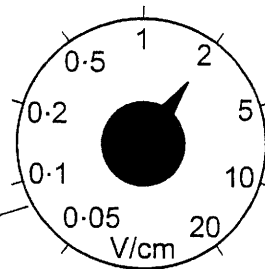
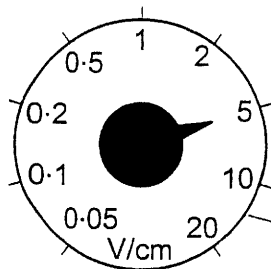
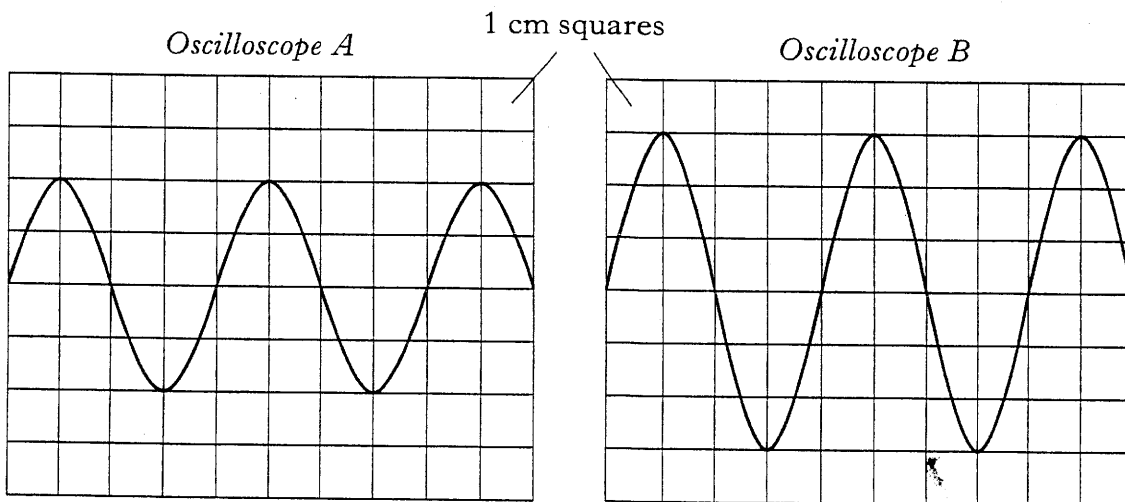

voltage scale settings

What is the peak voltage across

- (i) the power supply terminals? 1
- (ii) resistor  $R_1$ ? 1
- (iii) resistor  $R_2$ ? 1



26. (continued)

- (c) How does the quoted value of the a.c. supply voltage compare to your answer in (b)(i)? 1
- (d) The student now connects some LEDs to a 2 V d.c. supply as shown.

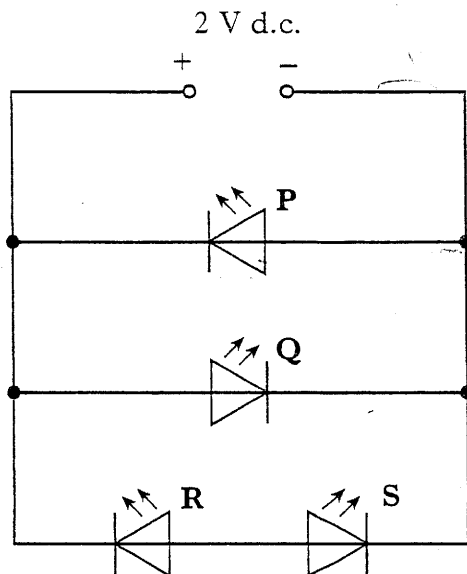

Which of the LEDs P, Q, R and S will light? 1

- (e) The student now replaces the 2 V d.c. supply with a 2 V a.c. supply as shown.

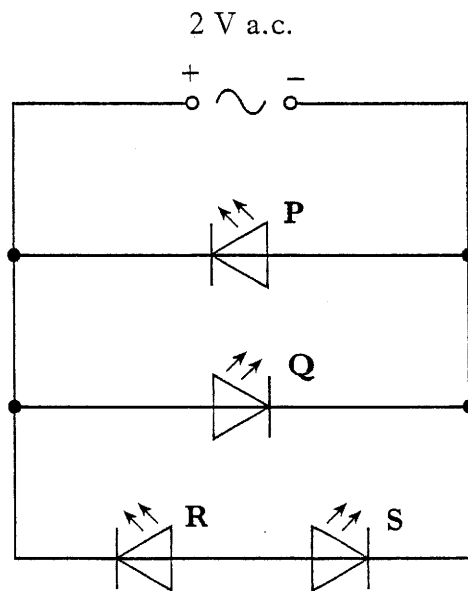

Which LED or LEDs will **now** light? 1

(8)

[Turn over

27. A student investigates solar cells connected in series. She uses a lamp with a dimmer control, a light meter, and a voltmeter as shown.

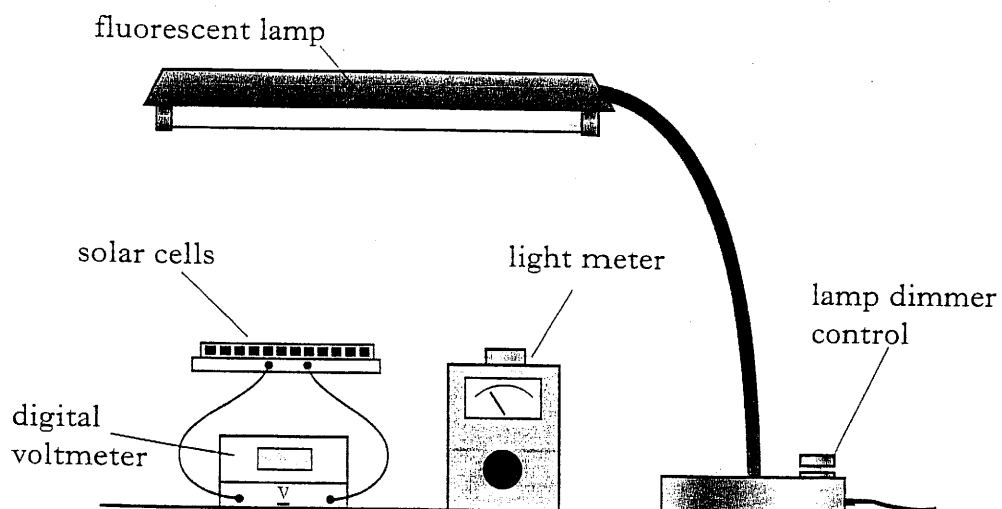

From her results, the student plots the following graph of the output voltage of the solar cells against the reading shown on the light meter.

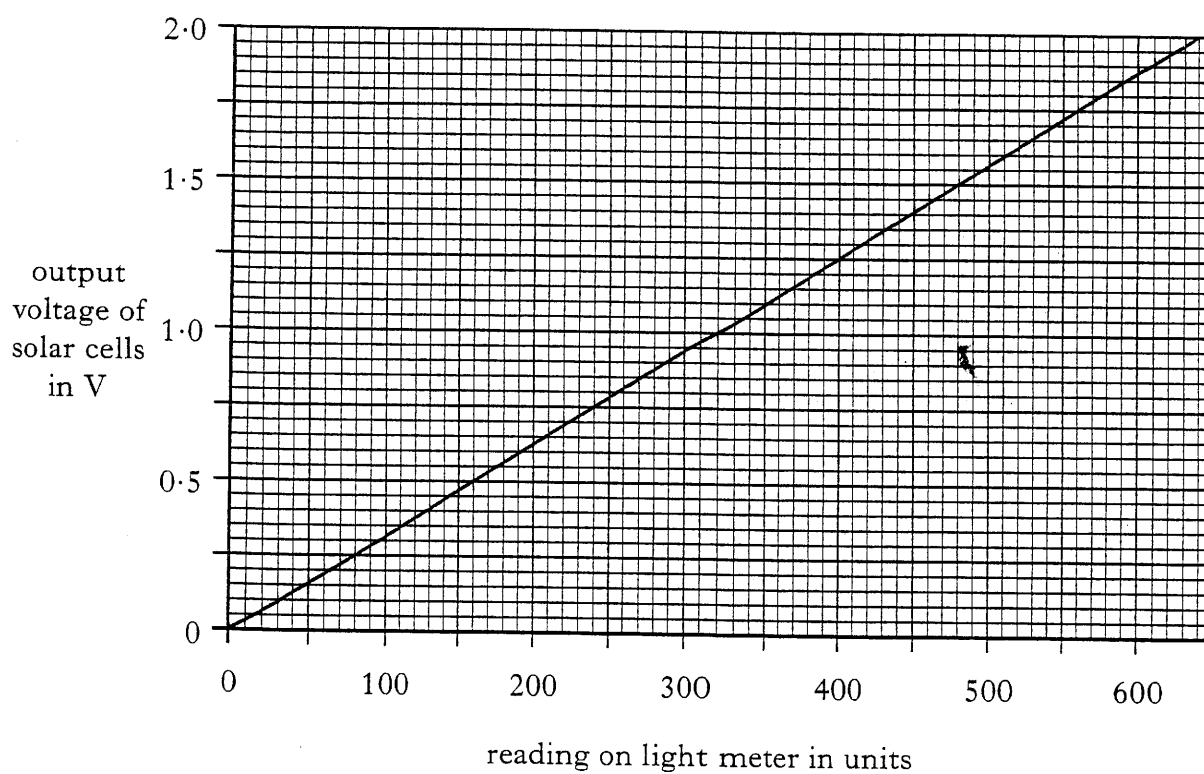

27. (continued)

- (a) What reading on the light meter (in units) gives an output voltage of 0.7 V from the cells? 1
- (b) Why should the cells be positioned at the same height as the light meter? 1
- (c) There are four solar cells connected in series. The circuit symbol for one solar cell is



Sketch a circuit diagram of the solar cells connected to the voltmeter. 1

- (d) The student now constructs the following circuit to show how the solar cells could operate the motor-driven sun shade above a shop window.

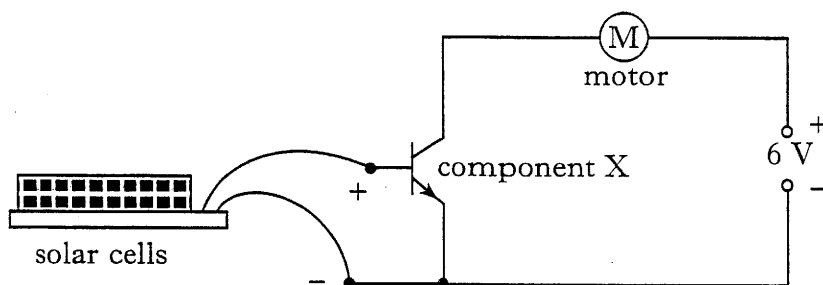

- (i) Name component X. 1
- (ii) Explain how this circuit operates the motor of the sun shade when the sunlight has become sufficiently bright. 3

(7)

[Turn over

28. A student uses a lens of focal length 200 mm to produce a bright, sharp image of a lamp filament on a piece of white card.

The lamp filament is positioned at a distance of 300 mm from the lens.

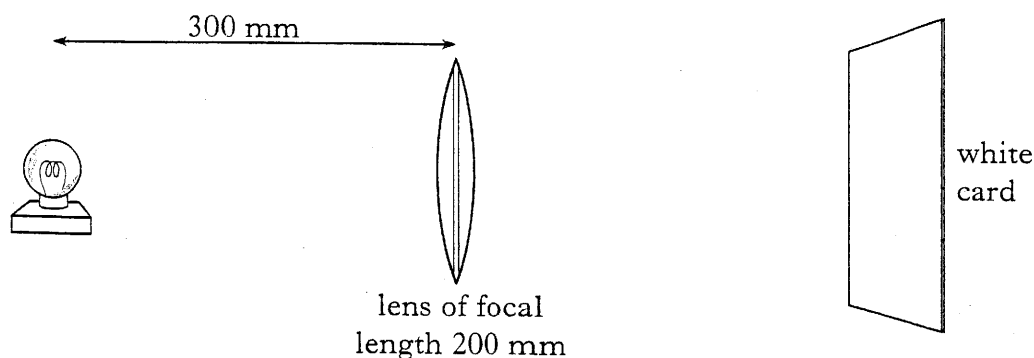

The student completes an accurate scale diagram of this experiment on the graph paper shown below. Points marked F are each one focal length from the lens. Point 2F is two focal lengths away. Two rays of light have been drawn in. The scale is shown. The piece of card and the image have not been shown.

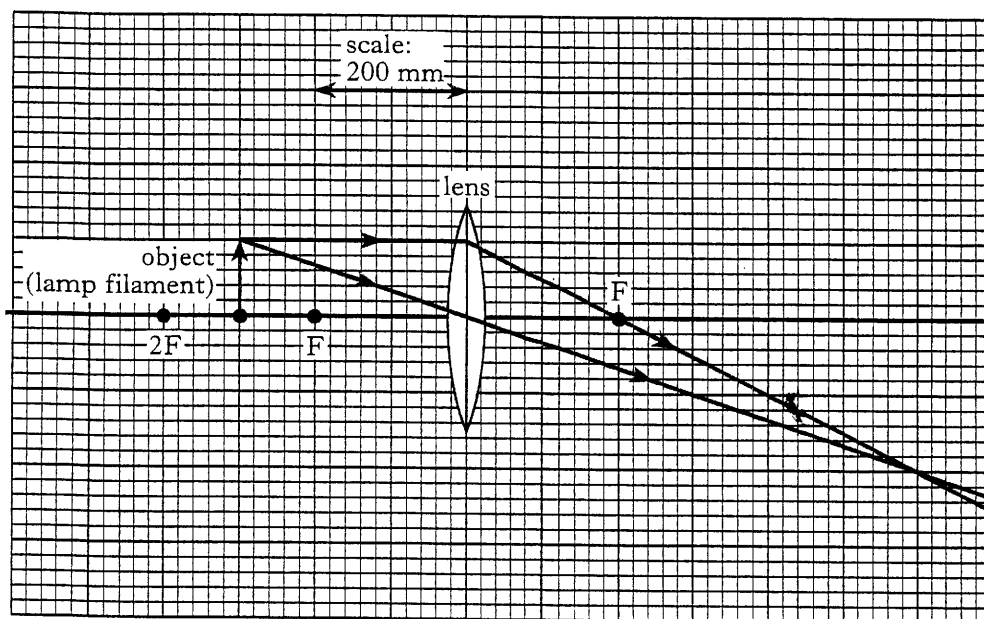

(a) By considering the scale diagram, answer the following questions.

- (i) What is the distance between the lens and the sharply focussed image on the card? 1
- (ii) How does the height of the image compare with the height of the object? 1
- (iii) State **one** other difference between the image and the object. 1

## 28. (continued)

- (b) The student now moves the object further away from the lens. In which direction must the card be moved to keep the image sharp? 1
- (c) Calculate the power of the lens used by the student. 2
- (d) A film projector in a cinema has a lens which forms an image of the film on a large, distant screen. The distance between the lens and the film is adjusted to produce a sharp image.

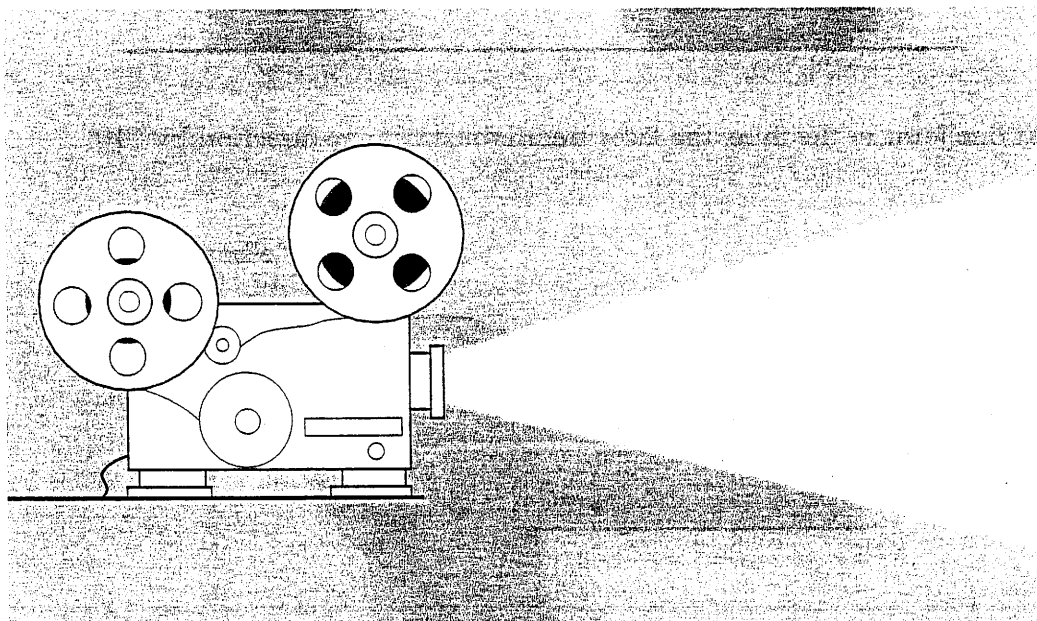

Describe the change which must be made to the distance between the lens and the film if the projector is moved to a smaller cinema where the screen is closer to the projector.

1  
(7)

[Turn over

29. (a) A large industrial laser is used to cut metal sheets in a factory. For safety, the laser beam travels to the metal along hollow tubes with jointed "elbows". There is a plane mirror inside each "elbow" joint.

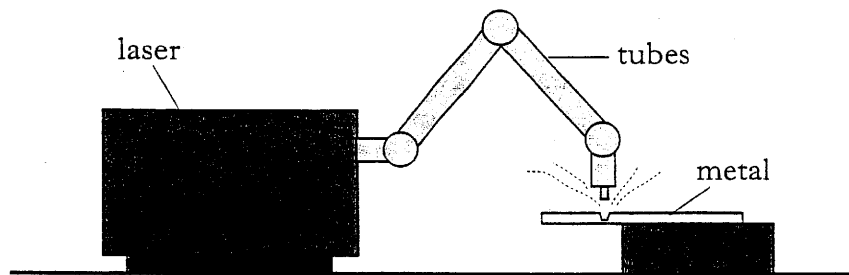

At one joint in the tube, the laser beam must change direction by  $110^\circ$ .

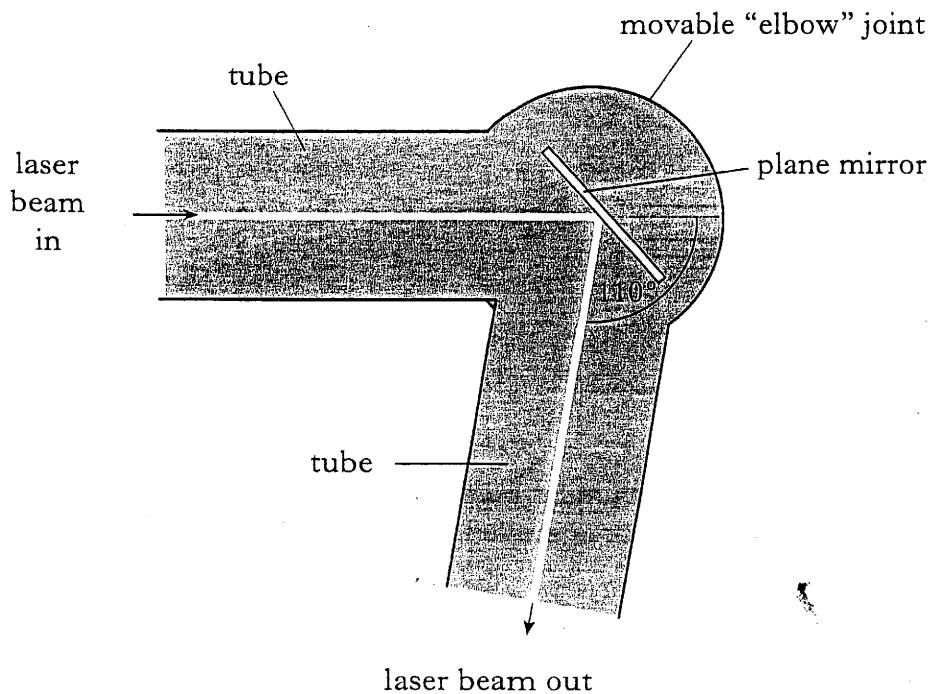

- |      |  |   |
|------|--|---|
| (i)  | What is the angle of incidence of the laser beam at the mirror?  | 1 |
| (ii) | What is the angle of reflection of the laser beam at the mirror? | 1 |

- (b) A student aims a laser beam at a triangular glass prism as shown. The beam changes direction at point X.

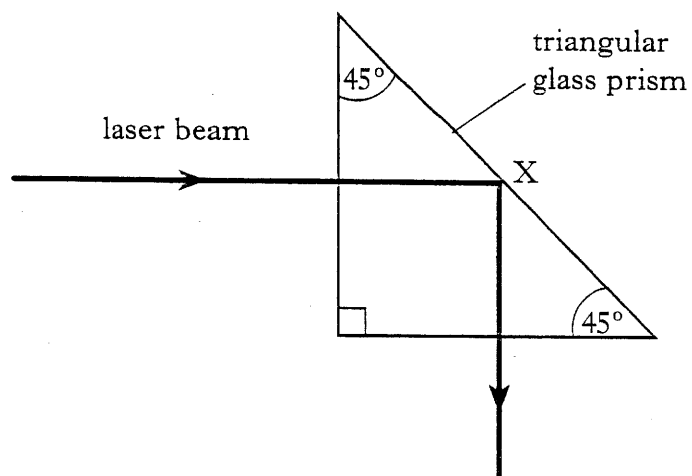

- (i) Name the optical effect which occurs at point X. 1
- (ii) Suggest a suitable value of the critical angle for the type of glass used for this prism. 2

You **must** explain your answer. (5)

[Turn over

30. A spark counter consists of a thin bare wire at a high voltage, mounted on insulators beneath an earthed metal grid. There is an insulating air gap between the wire and the grid. The apparatus is connected to a sensitive microammeter and a high voltage supply as shown. The voltage of the supply is 5 kV.

When a student brings a radioactive source close to the spark counter, the air between the wire and grid is ionised and sparks jump between the wire and the grid.

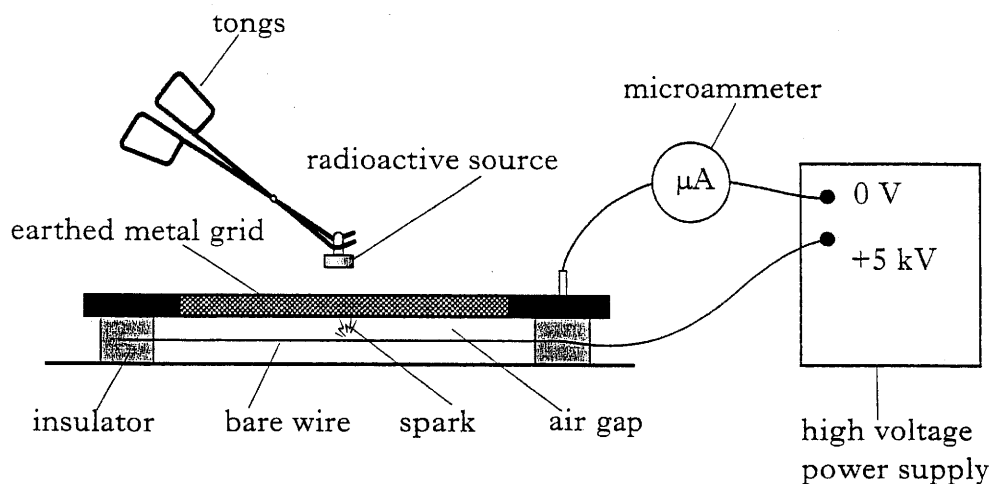

- (a) The radioactive source emits alpha particles and beta particles.  
State what is meant by:
- an alpha particle; 1
  - a beta particle. 1
- (b) The student finds that if the source is 3 cm from the grid, there is almost continuous sparking. When the distance is increased to 6 cm, there are very few sparks.
- Explain what is meant by *ionisation*. 1
  - Which of the two types of radiation in (a) above is more effective at producing sparks? Explain your answer using the student's results. 2
- (c) The student now fixes the source 5 cm above the grid. Over a period of 1 minute, the student counts 87 sparks. During this period the average reading on the microammeter is  $0.29 \mu\text{A}$ .

Calculate the average quantity of charge which is transferred from the wire to the grid by each spark. 3

(8)



31. The table shows properties of some isotopes of the element iodine.

<i>Isotope</i>	<i>Radiation emitted</i>	<i>Half-life</i>
Iodine-127	none	—
Iodine-128	beta	25 minutes
Iodine-129	beta	16 million years
Iodine-131	beta	8.1 days
Iodine-135	beta	6.7 hours

- (a) Explain what is meant by the term *half-life*. 1

- (b) The activity of a sample of iodine-131 is 56.0 MBq.  
How long will it take for its activity to reach 1.75 MBq? 2

- (c) A patient suffers from cancer of the thyroid gland. This cancer is treated with an injection of a radioactive iodine isotope, which becomes concentrated in the thyroid gland. The thyroid receives a large dose of radiation for several hours, but surrounding tissues receive much less. Next day, when the activity of the isotope has decreased to a safe level, the patient can return home.

Which of the above isotopes would be the most suitable to treat the patient?

Explain your answer. 2

- (d) Iodine is a necessary mineral in the diet. Some people do not receive sufficient iodine in their diet to remain healthy.

Which of the above iodine isotopes should be given to such people to supplement their diet?

Explain your answer. 2  
(7)

[END OF QUESTION PAPER]