

# S3 National 5

## Block Test 2 Revision Sheet

### Non-Calculator

#### Fractions

##### Question 1

(a)  $\frac{2}{5} + \frac{1}{5}$

(b)  $\frac{4}{5} + \frac{2}{3}$

(c)  $\frac{8}{9} - \frac{2}{3}$

(d)  $\frac{4}{5} - \frac{3}{8}$

(e)  $2\frac{4}{5} + 3\frac{3}{4}$

(f)  $1\frac{1}{7} + \frac{3}{5}$

(g)  $5\frac{2}{3} - 3\frac{3}{5}$

(h)  $5\frac{1}{3} - 2\frac{3}{4}$

##### Question 2

(a)  $\frac{4}{9} \times \frac{7}{8}$

(b)  $\frac{2}{3} \times \frac{9}{16}$

(c)  $2\frac{1}{3} \times 1\frac{1}{5}$

(d)  $5\frac{5}{6} \times 1\frac{3}{7}$

(e)  $\frac{5}{6} \div \frac{2}{3}$

(f)  $\frac{7}{9} \div \frac{2}{3}$

(g)  $\frac{15}{7} \div \frac{5}{14}$

(h)  $3\frac{5}{9} \div 2\frac{2}{3}$

##### Question 3

Find:

(a)  $\frac{1}{2} + \frac{1}{3} \times \frac{1}{6}$

(b)  $\frac{5}{6} - \frac{1}{5} \times \frac{5}{12}$

(c)  $\frac{3}{4} \left( \frac{1}{3} + \frac{2}{7} \right)$

(d)  $\frac{2}{11}$  of  $5\frac{1}{2} \times \frac{1}{6}$

(e)  $\left( \frac{11}{14} \text{ of } 2\frac{4}{5} \right) \div \frac{3}{4}$

(f)  $1\frac{1}{7}$  of  $\left( 2\frac{3}{4} - \frac{7}{8} \right)$

#### Function Notation

##### Question 1

A function is defined as  $f(x) = x^2 - 4x$ .

Find:

(a)  $f(4)$

(b)  $f(-1)$

(c)  $f(a)$

##### Question 2

A function is defined as  $f(x) = 5x + 3$ . Find the value of  $x$  when:

(a)  $f(x) = 23$

(b)  $f(x) = -2$

(c)  $f(x) = 5$

## Algebraic Expressions

### Question 1

Expand and simplify:

- |                       |                      |                     |
|-----------------------|----------------------|---------------------|
| (a) $3(2a + 1) + a$   | (b) $2(3x + 1) - 2x$ | (c) $5(b + 1) - 11$ |
| (d) $5(2g - 1) + 3$   | (e) $3(3 - 4y) + 7y$ | (f) $3(4c + 1) - 6$ |
| (g) $4(3h + 1) - 10h$ | (h) $a(b + 2) + 2ab$ | (i) $7(2 - 3m) - 8$ |
| (j) $6 + 2(4y - 3)$   | (k) $5a + 2(2a - 3)$ | (l) $7 - 2(2p - 3)$ |
| (m) $6 + 5(3y - 2)$   | (n) $7b - 3(2b - 3)$ | (o) $8 - 2(5y - 3)$ |
| (p) $2x - 3(2x - 5)$  | (q) $3c + 2(1 - 3c)$ | (r) $9 - 2(6g - 1)$ |

### Question 2

Multiply out and collect like terms:

- |                       |                        |                        |
|-----------------------|------------------------|------------------------|
| (a) $(3x - 3)(x - 5)$ | (b) $(a + 1)(2a + 4)$  | (c) $(y - 7)(2y - 2)$  |
| (d) $(3c + 2)(c + 7)$ | (e) $(b - 1)(3b - 8)$  | (f) $(5p + 11)(p + 1)$ |
| (g) $(4z + 2)(z - 3)$ | (h) $(2x + 1)(2x - 3)$ | (i) $(c - 4)(2c + 3)$  |
| (j) $(5p - 7)(p + 4)$ | (k) $(3x - 2)(2x + 1)$ | (l) $(a + 1)(7a + 6)$  |
| (m) $(y - 1)(3y - 1)$ | (n) $(3c + 2)(3c - 2)$ | (o) $(2b + 1)(4b + 2)$ |

### Question 3

Multiply out and collect like terms:

- |                 |                 |                 |
|-----------------|-----------------|-----------------|
| (a) $(x + 1)^2$ | (b) $(w - 3)^2$ | (c) $(a - 4)^2$ |
| (d) $(y - 8)^2$ | (e) $(a + 7)^2$ | (f) $(c - 1)^2$ |

### Question 4

Multiply out and collect like terms:

- |                              |                              |
|------------------------------|------------------------------|
| (a) $(x + 2)(x^2 + 3x - 1)$  | (b) $(p - 3)(p^2 - 3p + 2)$  |
| (c) $(u - 4)(u^2 - 3u - 1)$  | (d) $(3a - 4)(a^2 - 3a - 5)$ |
| (e) $(2n - 3)(4n^2 - n + 5)$ | (f) $(2p - 4)(p^2 + 2p + 4)$ |

### Question 5

Factorise fully:

- |                      |                      |                     |                     |
|----------------------|----------------------|---------------------|---------------------|
| (a) $x^2 - 4x$       | (b) $x^2 + 12x + 35$ | (c) $a^2 - 36$      | (d) $x^2 + 5x - 14$ |
| (e) $x^2 - 12x + 32$ | (f) $x^2 - 9x - 36$  | (g) $5x^2 + 60$     | (h) $x^2 - 8x - 20$ |
| (i) $a^2 - 14a + 40$ | (j) $x^2 + 10x - 24$ | (k) $2d^2 + 9d - 5$ | (l) $3g^2 - 48$     |
| (m) $h^2 + 15h + 14$ | (n) $n^2 + 6n - 16$  | (o) $5p^2 - 2p - 7$ | (p) $2u^2 - 18w^2$  |

## Changing the Subject of the Formula

### Question 1

Change the subject of each formula to  $x$ :

(a)  $y = x + 3$

(b)  $y = x - b$

(c)  $y = kx$

(d)  $y = x - 5t$

(e)  $y = 7x + 4a$

(f)  $y = ax + b$

(g)  $p = qx + 2r$

(h)  $k = h - mx$

### Question 2

Change the subject of each formula to  $x$ :

(a)  $y = \frac{3}{x}$

(b)  $s = \frac{a+2}{x}$

(c)  $a = \frac{x+8}{9}$

(d)  $y = \frac{2}{x} + 1$

(e)  $v^2 = u^2 + 2ax$

(f)  $L = 3 + \sqrt{6x}$

(g)  $2k = \sqrt{(x+4)}$

(h)  $y^2 = \frac{4xz}{t}$

## Straight Line

### Question 1

State the gradient and coordinates of the  $y$ -intercept point for each line below:

(a)  $y = x - 7$

(b)  $y = -5x + 3$

(c)  $5y = 3x - 10$

(d)  $y = -4x$

(e)  $2x + y = 11$

(f)  $2y = x - 5$

(g)  $3y - x = 18$

(h)  $3x + 7y - 21 = 0$

(i)  $4x - 5y = 20$

### Question 2

Write down the equation of the line:

(a) with gradient 4, passing through the point (0,5)

(b) with gradient -2, passing through the point (0,1)

(c) with gradient  $\frac{3}{4}$ , passing through the point (0,-3)

### Question 3

Establish the equation of the line passing through each pair of points below:

(a) A(2, 1) and B(6, 13)

(b) C(3, 4) and D(5, -4)

(c) E(-2, -1) and F(6,3)

(d) G(4, -13) and H(-2, -1)

(e) I(2, 8) and J(10, 12)

(f) K(-3, 2) and L(9, -2)

## Statistics

### Question 1

Find the median, the upper and lower quartiles and the semi-interquartile range for:

(a) 1 2 4 7 7 10 13

(b) 12 13 15 20 23 23 25 26 27

### Question 2

The midday temperatures in Grantford were recorded over a nine day period.  
The temperatures, in  $^{\circ}\text{C}$ , were

4 7 4 3 6 10 9 5 3

(a) Calculate the median and semi-interquartile range for these temperatures.

Over the same nine day period, the midday temperatures in Endoch were also recorded.

The median temperature was  $8^{\circ}\text{C}$ , and the semi-interquartile range was  $1.5^{\circ}\text{C}$ .

(b) Make two valid comments comparing the midday temperatures of Grantford and Endoch during this period.

### Question 3

A cattle farmer records the weight of some of his calves.

The scattergraph shows the relationship between age,  $A$  months, and the weight,  $W$  kilograms, of the calves.

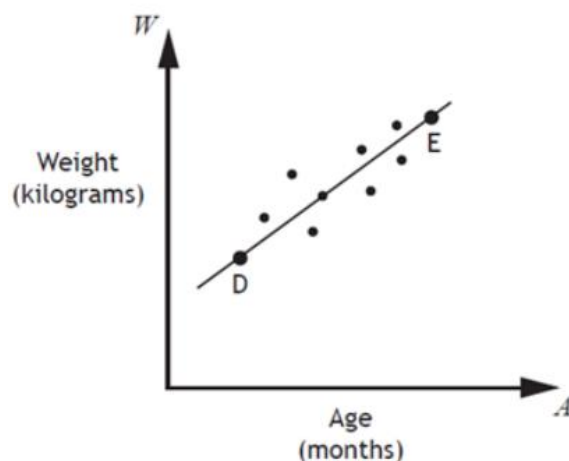

A line of best fit is drawn.

Point D represents a 3 month old calf which weighs 100 kilograms.

Point E represents a 15 month old calf which weighs 340 kilograms.

(a) Find the equation of the line of best fit in terms of  $A$  and  $W$ .

Give the equation in its simplest form.

(b) Use your equation from part (a) to estimate the weight of a one year old calf.

**Show your working.**

#### Question 4

Ten couples took part in a dance competition.  
The couples were given a score in each round.  
The scores in the first round were:

16 27 12 18 26 21 27 22 18 17

- (a) Calculate the median and semi-interquartile range of these scores.  
(b) In the second round, the median was 26 and the semi-interquartile range was 2.5.  
Make two valid comparisons between the scores in the first and second rounds.

### Percentages

#### Question 1

480 000 tickets were sold for a tennis tournament last year.  
This represents 80% of all the available tickets.  
Calculate the total number of tickets that were available for this tournament.

#### Question 2

Marmalade is on special offer.  
Each jar on special offer contains 12.5% more than the standard jar.

A jar on special offer contains 450 g of marmalade.  
How much does the standard jar contain?



### Trigonometry

#### Question 1

In triangle XYZ:

- $XZ = 10$  centimetres
- $YZ = 8$  centimetres
- $\cos Z = \frac{1}{8}$ .

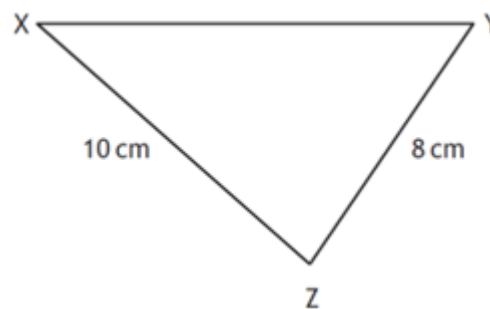

Calculate the length of XY.

#### Question 2

In triangle DEF:

- $DE = 8$  centimetres
- $EF = 12$  centimetres
- $\sin E = \frac{2}{3}$ .

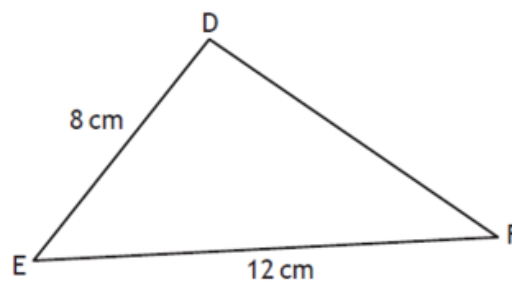

Calculate the area of triangle DEF.

### Question 3

In triangle KLM:

- $KM = 18$  centimetres
- $\sin K = 0.4$
- $\sin L = 0.9$

Calculate the length of LM.

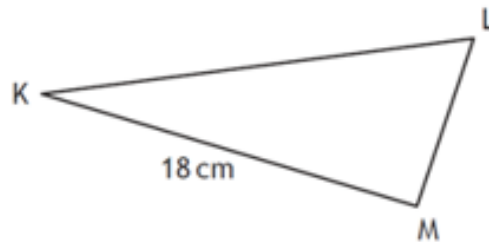

### Volume

#### Question 1

A hanging basket is in the shape of a cone.

The diameter is 20 centimetres and the height is 18 centimetres.

Calculate the volume of the hanging basket.

Take  $\pi = 3.14$ .

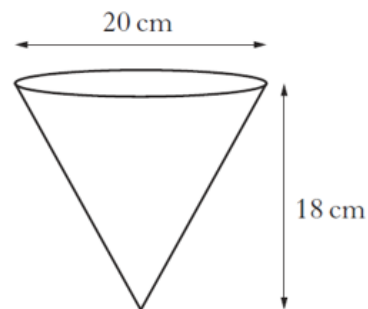

#### Question 2

A tin of tuna is in the shape of a cylinder.

It has diameter 10 centimetres and height 4 centimetres.

Calculate its volume.

Take  $\pi = 3.14$ .

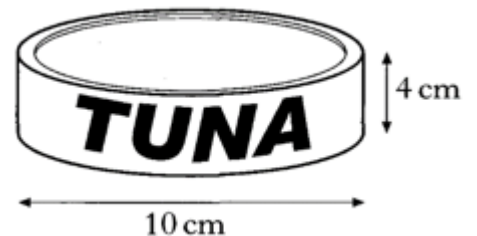

#### Question 3

The diagram shows a cone.

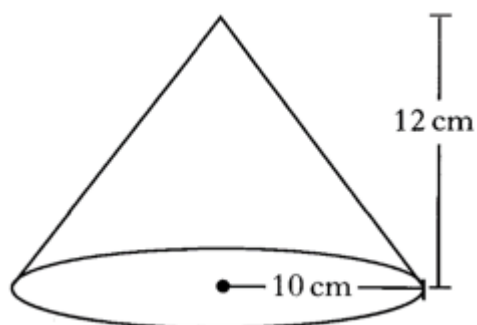

The height is 12 centimetres and the radius of the base is 10 centimetres.

Calculate the volume of the cone.

Take  $\pi = 3.14$ .

**Question 4**

A square based pyramid is shown in the diagram below.

The square base has length 6 centimetres.

The volume is 138 cubic centimetres.

Calculate the height of the pyramid.

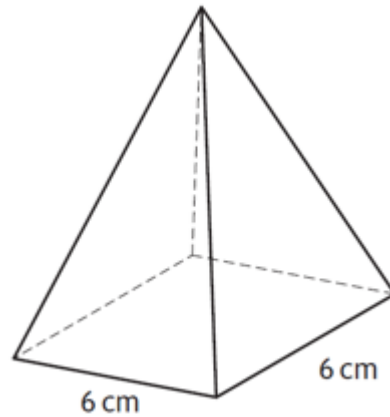
**Scientific Notation****Question 1**

Write each of the following numbers in scientific notation:

- |           |                |         |                     |
|-----------|----------------|---------|---------------------|
| (a) 1 200 | (b) 4 125 000  | (c) 225 | (d) 67 000          |
| (e) 9     | (f) 41 000 000 | (g) 92  | (h) 240 000 000 000 |

**Question 2**

Write each of the following numbers in scientific notation:

- |             |              |                 |                         |
|-------------|--------------|-----------------|-------------------------|
| (a) 0.057   | (b) 0.002 1  | (c) 0.84        | (d) 0.000 000 000 091 5 |
| (e) 0.000 7 | (f) 0.080 04 | (g) 0.000 001 2 |                         |

**Question 3**

Write each of the following numbers out in full:

- |                            |                          |                          |                             |
|----------------------------|--------------------------|--------------------------|-----------------------------|
| (a) $1.6 \times 10^5$      | (b) $2.78 \times 10^3$   | (c) $1.22 \times 10^8$   | (d) $4 \times 10^4$         |
| (e) $2.003 \times 10^2$    | (f) $5.7 \times 10^0$    | (g) $6 \times 10^{-3}$   | (h) $4.52 \times 10^{-6}$   |
| (i) $1.003 \times 10^{-4}$ | (j) $7.2 \times 10^{-5}$ | (k) $2.3 \times 10^{-2}$ | (l) $6.0004 \times 10^{-3}$ |

# Calculator

## Percentages

### Question 1

The Smiths buy a house for £60 000. If it appreciates in value at the rate of 9% per year, how much will it be worth in 5 years time?

### Question 2

Amanda wins some money and decides to spend £200 on some jewellery. If it appreciates at the rate of 2% per year, how much will the jewellery be worth 3 years from now?

### Question 3

In 1990 the world population was estimated to be 5 300 million, and was increasing at the rate of 1.7% per annum.

What will the population be in the year 2000?  
Give your answer correct to **two** significant figures.

### Question 4

Peter buys a car for £3 000. If it depreciates at the rate of 20% per annum, how much will he be able to sell it for in 3 years time?

### Question 5

Brian buys a new car costing £12 600. It depreciates in value by 30% in the first year and by 20% each year after that.

How much will he be able to trade it in for in 3 years time?

### Question 6

An industrial machine costs £176 500.  
Its value depreciates by 4.25% each year.  
How much is it worth after 3 years?  
Give your answer correct to **three** significant figures.

### Question 7

A theatre group sold 4 830 tickets for their show.  
This was 15% more than they sold last year.  
How many tickets did they sell last year?

### Question 8

James paid £297.50 for a laptop in a sale.  
The discount in the sale was 15%.  
Calculate the original price of the laptop.



## Trigonometry

### Question 1

Calculate the value of  $x$  in each triangle below:

(a)

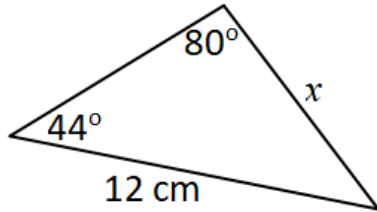

(b)

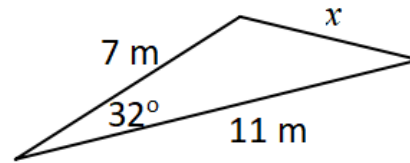

(c)

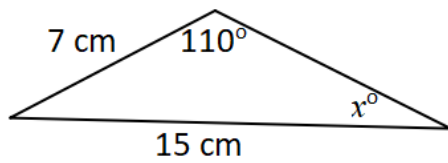

(d)

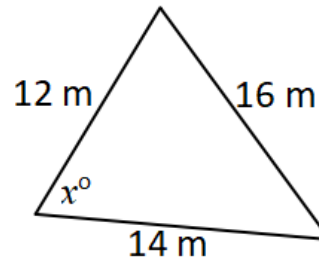

### Question 2

Using the diagram opposite, calculate:

- the length of  $BD$ .
- the length of  $AD$ .
- the area of triangle  $ABC$ .

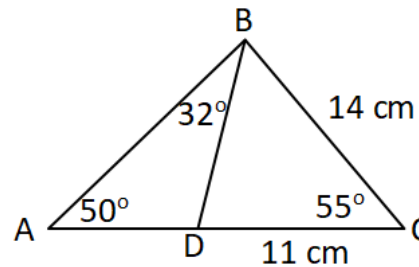

### Question 3

Using the diagram opposite, calculate:

- the length of  $AC$ .
- the size of angle  $BAC$ .
- the size of angle  $ACD$ .
- the length of  $AD$ .
- the area of quadrilateral  $ABCD$ .

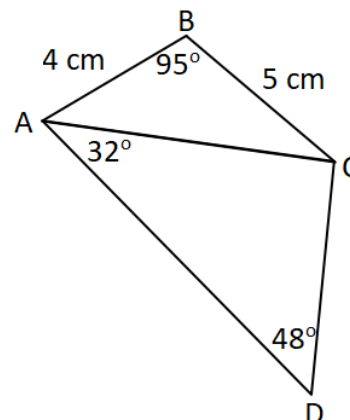

**Question 4**

Calculate the value of  $h$  in the following diagram:

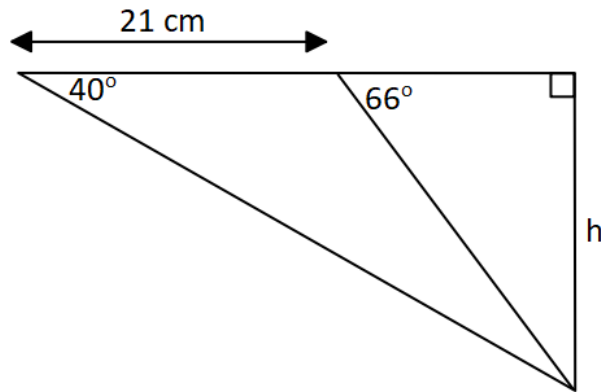

**Question 5**

David walks on a bearing of  $050^\circ$  from hostel A to a viewpoint V, 5 kilometres away.

Hostel B is due east of hostel A.

Susie walks on a bearing of  $294^\circ$  from hostel B to the same viewpoint.

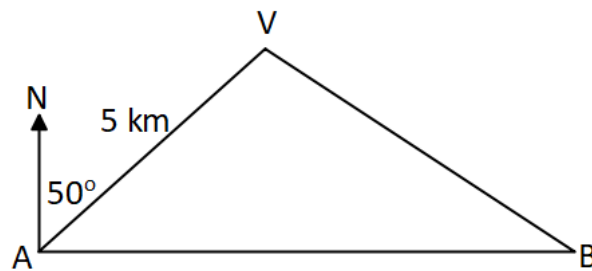

Calculate the length of  $AB$ , the distance between the two hostels.

## Statistics

### Question 1

A frozen food company uses machines to pack sprouts into bags.

A sample of six bags is taken from Machine A and the number of sprouts in each bag is counted.

The results are shown below.

23 19 21 20 19 24

- (a) Calculate the mean and standard deviation of this sample.
- (b) Another sample of six bags is taken from Machine B.  
This sample has a mean of 19 and a standard deviation of 2.3.  
Write down two valid comparisons between the samples.

### Question 2

A runner has recorded her times, in seconds, for six different laps of the running track.

53 57 58 60 55 56

- (a) Calculate:
  - (i) the mean;
  - (ii) the standard deviation;of these lap times.

**Show clearly all your working.**

- (b) She changes her training routine hoping to improve her consistency. After this change, she records her times for another six laps.

The mean is 55 seconds and the standard deviation is 3.2 seconds.  
Has the new training routine improved her consistency?

**Explain clearly your answer.**

## Volume

### Question 1

Calculate the volume of the following shapes:

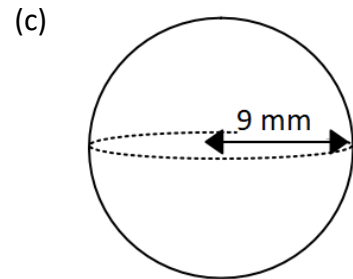
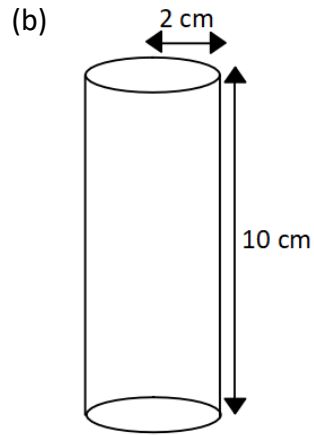
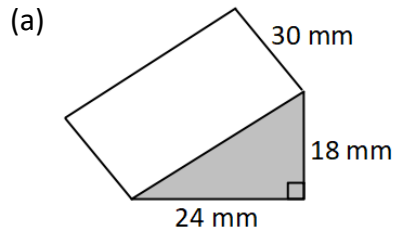

### Question 2

A storage barn is in the shape of a cylinder with a hemisphere on top. Calculate the volume of the storage barn.

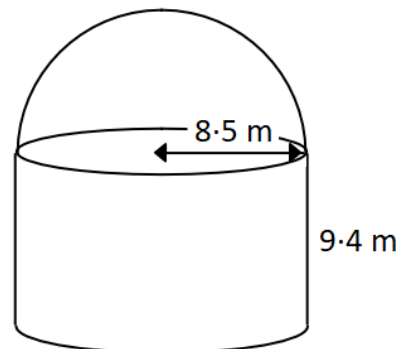

### Question 3

The diagram opposite shows a child's toy in the shape of two cones. Calculate the volume of this shape.

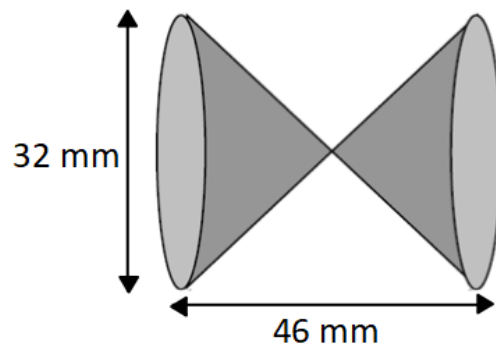

#### Question 4

A mug in the shape of a cylinder has a volume of 400 cubic centimetres. Its diameter is 7.6 centimetres.



Calculate the height of the mug, giving your answer correct to one decimal place.

### Scientific Notation

#### Question 1

Calculate each of the following expressing your answer in scientific notation:

(a)  $(2 \times 10^3) \times (3 \times 10^5)$

(b)  $(9 \times 10^7) \div (1.5 \times 10^2)$

(c)  $\frac{1.28 \times 10^6}{0.4 \times 10^2}$

(d)  $\frac{1.8 \times 10^{-2}}{0.2 \times 10^5}$

#### Question 2

Answer each of the following questions leaving your answers in standard form and correct to 3 significant figures where necessary:

(a) Light travels at  $1.85 \times 10^5$  miles per second. How far will it travel in an hour?

(b) In 1 gram of carbon there are  $6 \times 10^{26}$  atoms. How many carbon atoms are there in 5 kg of pure carbon?

#### Question 3

There are  $3 \times 10^5$  platelets per millilitre of blood.

On average, a person has 5.5 litres of blood.

On average, how many platelets does a person have in their blood?

Give your answer in scientific notation.