



National
Qualifications
SPECIMEN ONLY

SQ35/N5/01

**Physics
Section 1—Questions**

Date — Not applicable

Duration — 2 hours

Instructions for completion of Section 1 are given on Page two of the question paper SQ35/N5/02.

Record your answers on the grid on Page three of your answer booklet

Do NOT write in this booklet.

Before leaving the examination room you must give your answer booklet to the Invigilator. If you do not, you may lose all the marks for this paper.



* S Q 3 5 N 5 0 1 *

DATA SHEET

Speed of light in materials

| Material | Speed in ms^{-1} |
|----------------|---------------------------|
| Air | 3.0×10^8 |
| Carbon dioxide | 3.0×10^8 |
| Diamond | 1.2×10^8 |
| Glass | 2.0×10^8 |
| Glycerol | 2.1×10^8 |
| Water | 2.3×10^8 |

Speed of sound in materials

| Material | Speed in ms^{-1} |
|----------------|---------------------------|
| Aluminium | 5200 |
| Air | 340 |
| Bone | 4100 |
| Carbon dioxide | 270 |
| Glycerol | 1900 |
| Muscle | 1600 |
| Steel | 5200 |
| Tissue | 1500 |
| Water | 1500 |

Gravitational field strengths

| | Gravitational field strength on the surface in N kg^{-1} |
|---------|---|
| Earth | 9.8 |
| Jupiter | 23 |
| Mars | 3.7 |
| Mercury | 3.7 |
| Moon | 1.6 |
| Neptune | 11 |
| Saturn | 9.0 |
| Sun | 270 |
| Uranus | 8.7 |
| Venus | 8.9 |

Specific heat capacity of materials

| Material | Specific heat capacity in $\text{J kg}^{-1} \text{ } ^\circ\text{C}^{-1}$ |
|-----------|---|
| Alcohol | 2350 |
| Aluminium | 902 |
| Copper | 386 |
| Glass | 500 |
| Ice | 2100 |
| Iron | 480 |
| Lead | 128 |
| Oil | 2130 |
| Water | 4180 |

Specific latent heat of fusion of materials

| Material | Specific latent heat of fusion in J kg^{-1} |
|----------------|--|
| Alcohol | 0.99×10^5 |
| Aluminium | 3.95×10^5 |
| Carbon Dioxide | 1.80×10^5 |
| Copper | 2.05×10^5 |
| Iron | 2.67×10^5 |
| Lead | 0.25×10^5 |
| Water | 3.34×10^5 |

Melting and boiling points of materials

| Material | Melting point in $^\circ\text{C}$ | Boiling point in $^\circ\text{C}$ |
|-----------|-----------------------------------|-----------------------------------|
| Alcohol | -98 | 65 |
| Aluminium | 660 | 2470 |
| Copper | 1077 | 2567 |
| Glycerol | 18 | 290 |
| Lead | 328 | 1737 |
| Iron | 1537 | 2737 |

Specific latent heat of vaporisation of materials

| Material | Specific latent heat of vaporisation in J kg^{-1} |
|----------------|--|
| Alcohol | 11.2×10^5 |
| Carbon Dioxide | 3.77×10^5 |
| Glycerol | 8.30×10^5 |
| Turpentine | 2.90×10^5 |
| Water | 22.6×10^5 |

Radiation weighting factors

| Type of radiation | Radiation weighting factor |
|-------------------|----------------------------|
| alpha | 20 |
| beta | 1 |
| fast neutrons | 10 |
| gamma | 1 |
| slow neutrons | 3 |

SECTION 1

1. 1 volt is equivalent to
- A 1 ampere per watt
 - B 1 coulomb per second
 - C 1 joule per coulomb
 - D 1 joule per second
 - E 1 watt per second.
2. A conductor carries a current of 4.0 mA for 250 s.
The total charge passing a point in the conductor is

- A $1.6 \times 10^{-5} \text{ C}$
- B 1.0 C
- C 62.5 C
- D $1.0 \times 10^3 \text{ C}$
- E $6.25 \times 10^4 \text{ C}$.

3. A ball is released from rest and allowed to roll down a curved track as shown.

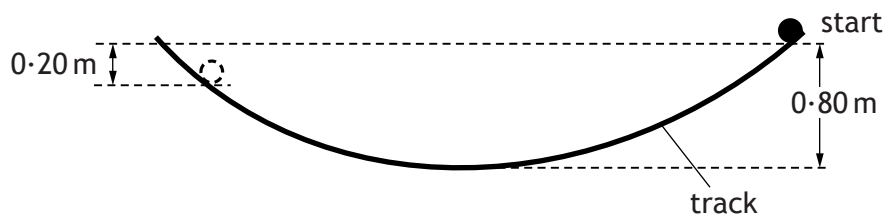

The mass of the ball is 0.50 kg.

The maximum height reached on the opposite side of the track is 0.20 m lower than the height of the starting point.

The amount of energy lost is

- A 0.080 J
- B 0.10 J
- C 0.98 J
- D 2.9 J
- E 3.9 J.

4. In the circuit shown, the current in each resistor is different.

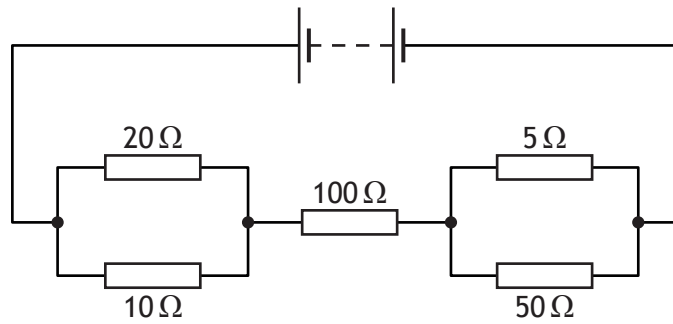

In which resistor is the current smallest?

- A 5 Ω
 - B 10 Ω
 - C 20 Ω
 - D 50 Ω
 - E 100 Ω
5. Three resistors are connected as shown.

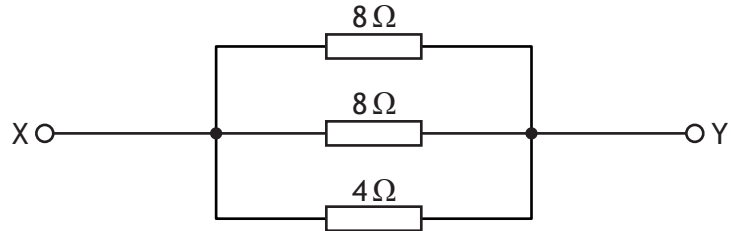

The resistance between X and Y is

- A 0.08 Ω
- B 0.5 Ω
- C 2 Ω
- D 13 Ω
- E 20 Ω.

6. A bicycle pump is sealed at one end and the piston pushed until the pressure of the trapped air increases to $4.00 \times 10^5 \text{ Pa}$.

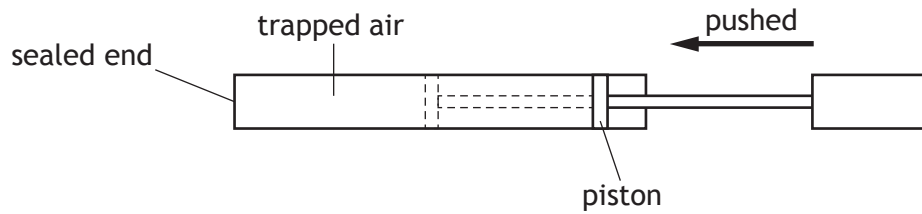

The area of the piston compressing the air is $5.00 \times 10^{-4} \text{ m}^2$.

The force that the trapped air exerts on the piston is

- A $1.25 \times 10^{-9} \text{ N}$
- B $8.00 \times 10^{-1} \text{ N}$
- C $2.00 \times 10^2 \text{ N}$
- D $8.00 \times 10^8 \text{ N}$
- E $2.00 \times 10^{10} \text{ N}$.

7. Which of the following diagrams shows the best method for an experiment to investigate the relationship between pressure and temperature for a fixed mass of gas?

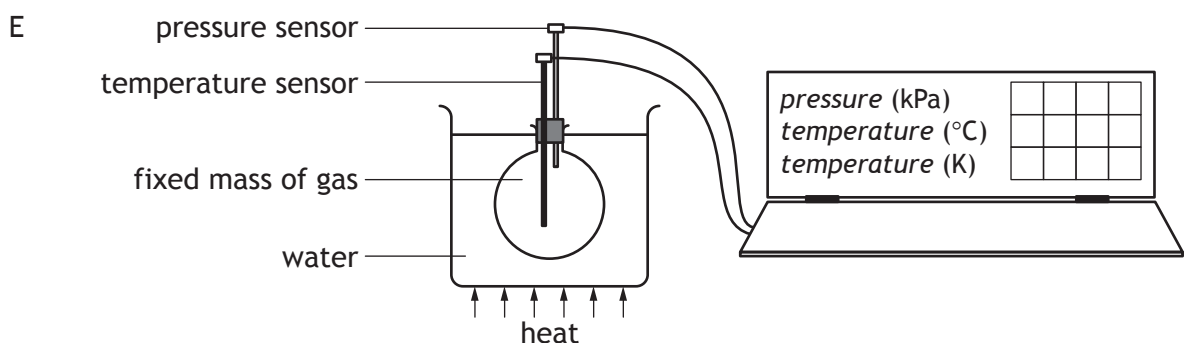
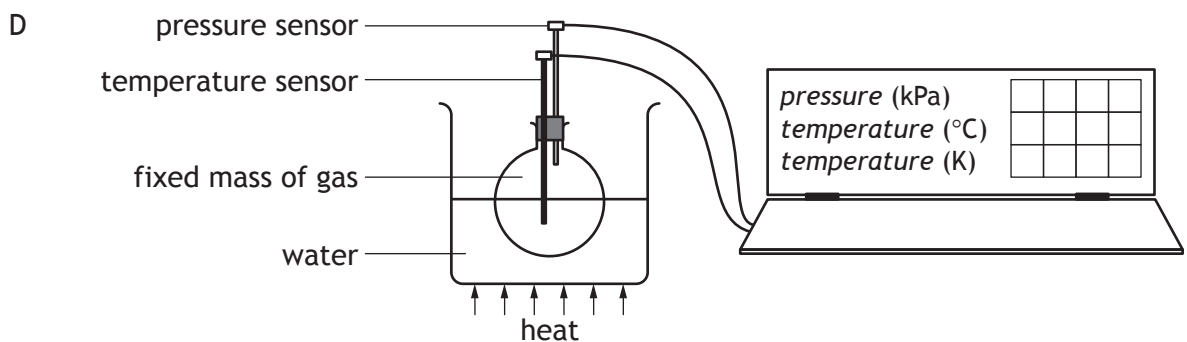
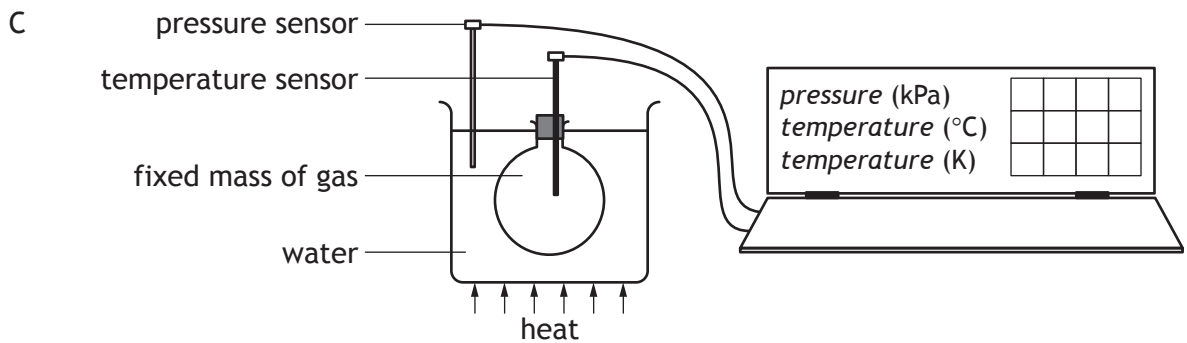
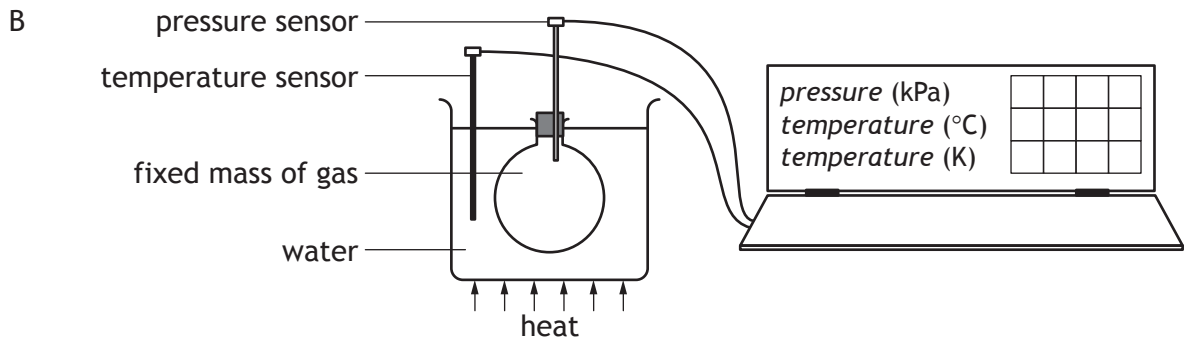
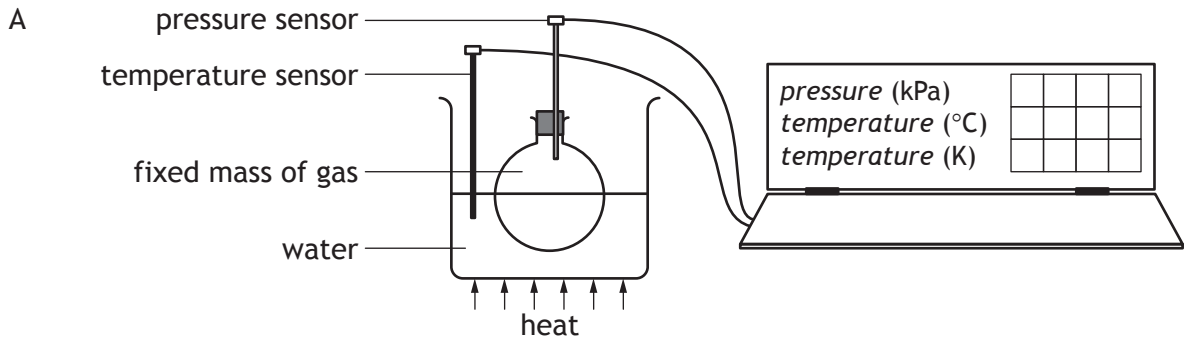

8. A fixed mass of gas is trapped inside a sealed container. The volume of the gas is slowly changed. The temperature of the gas remains constant.

Which graph shows how the pressure p of the gas varies with the volume V ?

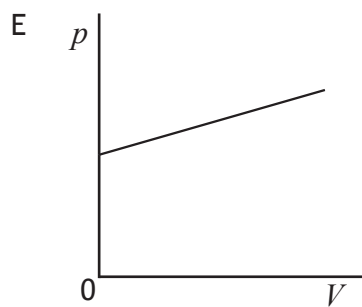
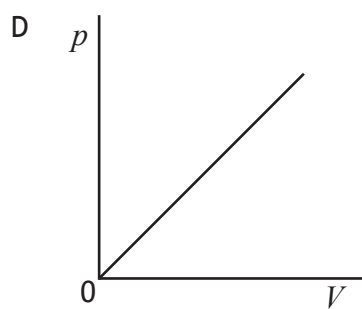
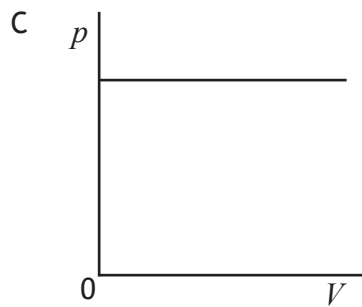
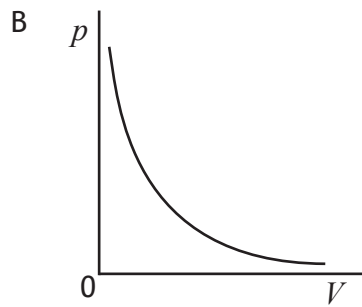
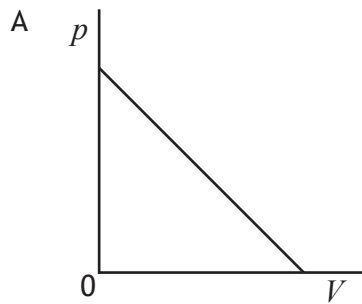

9. A student writes the following statements about electromagnetic waves.

- I Electromagnetic waves all travel at the same speed in air.
- II Electromagnetic waves all have the same frequency.
- III Electromagnetic waves all transfer energy.

Which of these statements is/are correct?

- A I only
- B II only
- C I and III only
- D II and III only
- E I, II and III

10. A satellite orbiting the Earth transmits television signals to a receiver.

The signals take a time of 150 ms to reach the receiver.

The distance between the satellite and the receiver is

- A 2.0×10^6 m
- B 2.25×10^7 m
- C 4.5×10^7 m
- D 2.0×10^9 m
- E 4.5×10^{10} m.

11. A wave machine in a swimming pool generates 15 waves per minute.

The wavelength of these waves is 2.0 m.

The frequency of the waves is

- A 0.25 Hz
- B 0.50 Hz
- C 4.0 Hz
- D 15 Hz
- E 30 Hz.

12. For a ray of light travelling from air into glass, which of the following statements is/are correct?

- I The speed of light always changes.
- II The speed of light sometimes changes.
- III The direction of light always changes.
- IV The direction of light sometimes changes.

- A I only
- B III only
- C I and III only
- D I and IV only
- E II and IV

13. A ray of red light is incident on a glass block as shown.

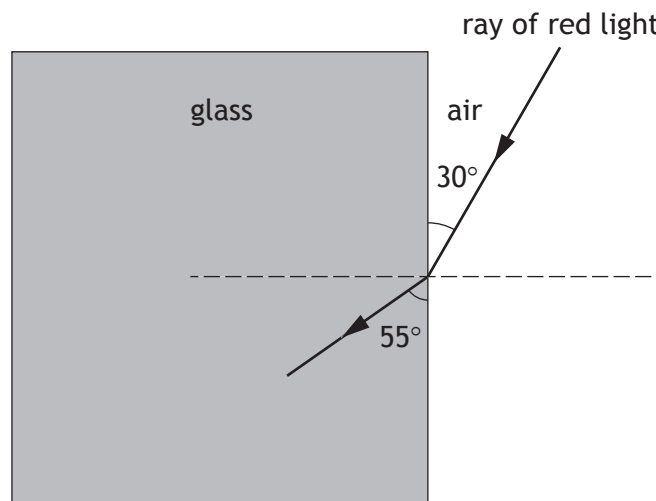

Which row in the table shows the values of the angle of incidence and angle of refraction?

| | <i>Angle of incidence</i> | <i>Angle of refraction</i> |
|---|---------------------------|----------------------------|
| A | 35° | 60° |
| B | 30° | 55° |
| C | 30° | 35° |
| D | 60° | 55° |
| E | 60° | 35° |

14. A student writes the following statements about the activity of a radioactive source.
- I The activity decreases with time.
 - II The activity is measured in becquerels.
 - III The activity is the number of decays per second.

Which of these statements is/are correct?

- A I only
 - B II only
 - C I and II only
 - D II and III only
 - E I, II and III
15. A worker in a nuclear power station is exposed to 3.0 mGy of gamma radiation and 0.50 mGy of fast neutrons.
- The radiation weighting factor for gamma radiation is 1 and for fast neutrons is 10.
- The total equivalent dose, in mSv, received by the worker is
- A 3.50
 - B 8.00
 - C 30.5
 - D 35.0
 - E 38.5.
16. Which of the following contains two scalar quantities?
- A Force and mass
 - B Weight and mass
 - C Displacement and speed
 - D Distance and speed
 - E Displacement and velocity

17. A student sets up the apparatus as shown.

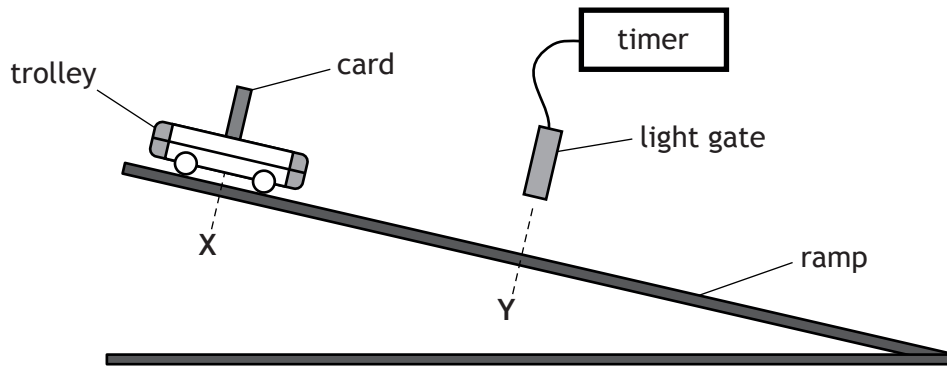

The trolley is released from X and moves down the ramp.

The following measurements are recorded.

time for card to pass through light gate = 0.08 s

distance from X to Y = 0.5 m

length of card = 40 mm

The instantaneous speed of the trolley at Y is

- A 0.5 m s^{-1}
- B 1.6 m s^{-1}
- C 2.0 m s^{-1}
- D 3.2 m s^{-1}
- E 6.3 m s^{-1} .

18. As a car approaches a village the driver applies the brakes. The speed-time graph of the car's motion is shown.

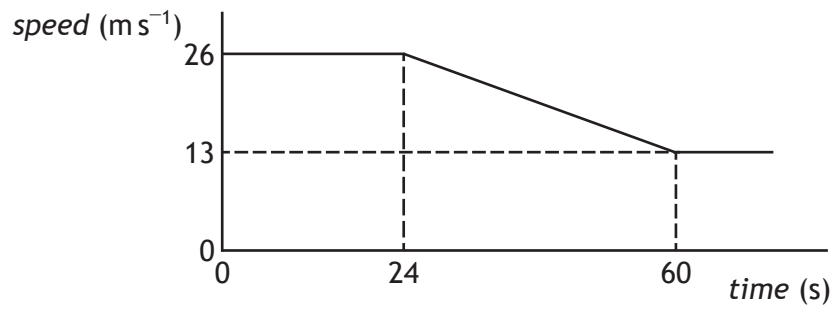

The brakes are applied for

- A 13 s
 - B 20 s
 - C 24 s
 - D 36 s
 - E 60 s.
19. The Mars Curiosity Rover has a mass of 900 kg.



Which row of the table gives the mass and weight of the Rover on Mars?

| | Mass (kg) | Weight (N) |
|---|-----------|------------|
| A | 243 | 243 |
| B | 243 | 900 |
| C | 900 | 900 |
| D | 900 | 3330 |
| E | 900 | 8820 |

20. An aircraft engine exerts a force on the air.

Which of the following completes the “Newton pair” of forces?

- A The force of the air on the aircraft engine
- B The force of friction between the aircraft engine and the air
- C The force of friction between the aircraft and the aircraft engine
- D The force of the Earth on the aircraft engine
- E The force of the aircraft engine on the Earth

**[END OF SECTION 1. NOW ATTEMPT THE QUESTIONS IN SECTION 2
OF YOUR QUESTION AND ANSWER BOOKLET]**



National
Qualifications
SPECIMEN ONLY

SQ35/N5/11

**Physics
Relationships Sheet**

Date — Not applicable



* S Q 3 5 N 5 1 1 *

$$E_p = mgh$$

$$d = vt$$

$$E_k = \frac{1}{2}mv^2$$

$$v = f\lambda$$

$$Q = It$$

$$T = \frac{1}{f}$$

$$V = IR$$

$$A = \frac{N}{t}$$

$$R_T = R_1 + R_2 + \dots$$

$$D = \frac{E}{m}$$

$$\frac{1}{R_T} = \frac{1}{R_1} + \frac{1}{R_2} + \dots$$

$$H = Dw_R$$

$$V_2 = \left(\frac{R_2}{R_1 + R_2} \right) V_s$$

$$\dot{H} = \frac{H}{t}$$

$$\frac{V_1}{V_2} = \frac{R_1}{R_2}$$

$$s = vt$$

$$P = \frac{E}{t}$$

$$d = \bar{v}t$$

$$P = IV$$

$$s = \bar{v}t$$

$$P = I^2R$$

$$a = \frac{v-u}{t}$$

$$P = \frac{V^2}{R}$$

$$W = mg$$

$$E_h = cm\Delta T$$

$$F = ma$$

$$p = \frac{F}{A}$$

$$E_w = Fd$$

$$\frac{pV}{T} = \text{constant}$$

$$E_h = ml$$

$$p_1V_1 = p_2V_2$$

$$\frac{p_1}{T_1} = \frac{p_2}{T_2}$$

$$\frac{V_1}{T_1} = \frac{V_2}{T_2}$$

[END OF SPECIMEN RELATIONSHIPS SHEET]

FOR OFFICIAL USE



National
Qualifications
SPECIMEN ONLY

Mark

SQ35/N5/02

**Physics Section 1—
Answer Grid and
Section 2**

Date — Not applicable

Duration — 2 hours



* S Q 3 5 N 5 0 2 *

Fill in these boxes and read what is printed below.

Full name of centre

Town

Forename(s)

Surname

Number of seat

Date of birth

Day

Month

Year

Scottish candidate number

Total marks — 110

SECTION 1 — 20 marks

Attempt ALL questions in this section.

Instructions for completion of Section 1 are given on Page two.

SECTION 2 — 90 marks

Attempt ALL questions in this section.

Read all questions carefully before answering.

Use blue or black ink. Do NOT use gel pens.

Write your answers in the spaces provided. Additional space for answers and rough work is provided at the end of this booklet. If you use this space, write clearly the number of the question you are answering. Any rough work must be written in this booklet. You should score through your rough work when you have written your fair copy.

Before leaving the examination room you must give this booklet to the Invigilator. If you do not, you may lose all the marks for this paper.



* S Q 3 5 N 5 0 2 0 1 *

The questions for Section 1 are contained in the booklet Physics Section 1 — Questions. Read these and record your answers on the grid on Page three opposite.

1. The answer to each question is **either** A, B, C, D or E. Decide what your answer is, then fill in the appropriate bubble (see sample question below).
2. There is **only one correct** answer to each question.
3. Any rough working should be done on the rough working sheet.

Sample Question

The energy unit measured by the electricity meter in your home is the:

- A ampere
- B kilowatt-hour
- C watt
- D coulomb
- E volt.

The correct answer is **B**—kilowatt-hour. The answer **B** bubble has been clearly filled in (see below).

| | | | | |
|-----------------------|----------------------------------|-----------------------|-----------------------|-----------------------|
| A | B | C | D | E |
| <input type="radio"/> | <input checked="" type="radio"/> | <input type="radio"/> | <input type="radio"/> | <input type="radio"/> |

Changing an answer

If you decide to change your answer, cancel your first answer by putting a cross through it (see below) and fill in the answer you want. The answer below has been changed to **D**.

| | | | | |
|-----------------------|----------------------------------|-----------------------|----------------------------------|-----------------------|
| A | B | C | D | E |
| <input type="radio"/> | <input checked="" type="radio"/> | <input type="radio"/> | <input checked="" type="radio"/> | <input type="radio"/> |

If you then decide to change back to an answer you have already scored out, put a tick (✓) to the **right** of the answer you want, as shown below:

| | | | | | | | | | | |
|-----------------------|----------------------------------|-----------------------|----------------------------------|-----------------------|----|-----------------------|----------------------------------|-----------------------|-----------------------|-----------------------|
| A | B | C | D | E | or | A | B | C | D | E |
| <input type="radio"/> | <input checked="" type="radio"/> | <input type="radio"/> | <input checked="" type="radio"/> | <input type="radio"/> | | <input type="radio"/> | <input checked="" type="radio"/> | <input type="radio"/> | <input type="radio"/> | <input type="radio"/> |



SECTION 1 — Answer Grid

| | A | B | C | D | E |
|----|-----------------------|-----------------------|-----------------------|-----------------------|-----------------------|
| 1 | <input type="radio"/> | <input type="radio"/> | <input type="radio"/> | <input type="radio"/> | <input type="radio"/> |
| 2 | <input type="radio"/> | <input type="radio"/> | <input type="radio"/> | <input type="radio"/> | <input type="radio"/> |
| 3 | <input type="radio"/> | <input type="radio"/> | <input type="radio"/> | <input type="radio"/> | <input type="radio"/> |
| 4 | <input type="radio"/> | <input type="radio"/> | <input type="radio"/> | <input type="radio"/> | <input type="radio"/> |
| 5 | <input type="radio"/> | <input type="radio"/> | <input type="radio"/> | <input type="radio"/> | <input type="radio"/> |
| 6 | <input type="radio"/> | <input type="radio"/> | <input type="radio"/> | <input type="radio"/> | <input type="radio"/> |
| 7 | <input type="radio"/> | <input type="radio"/> | <input type="radio"/> | <input type="radio"/> | <input type="radio"/> |
| 8 | <input type="radio"/> | <input type="radio"/> | <input type="radio"/> | <input type="radio"/> | <input type="radio"/> |
| 9 | <input type="radio"/> | <input type="radio"/> | <input type="radio"/> | <input type="radio"/> | <input type="radio"/> |
| 10 | <input type="radio"/> | <input type="radio"/> | <input type="radio"/> | <input type="radio"/> | <input type="radio"/> |
| 11 | <input type="radio"/> | <input type="radio"/> | <input type="radio"/> | <input type="radio"/> | <input type="radio"/> |
| 12 | <input type="radio"/> | <input type="radio"/> | <input type="radio"/> | <input type="radio"/> | <input type="radio"/> |
| 13 | <input type="radio"/> | <input type="radio"/> | <input type="radio"/> | <input type="radio"/> | <input type="radio"/> |
| 14 | <input type="radio"/> | <input type="radio"/> | <input type="radio"/> | <input type="radio"/> | <input type="radio"/> |
| 15 | <input type="radio"/> | <input type="radio"/> | <input type="radio"/> | <input type="radio"/> | <input type="radio"/> |
| 16 | <input type="radio"/> | <input type="radio"/> | <input type="radio"/> | <input type="radio"/> | <input type="radio"/> |
| 17 | <input type="radio"/> | <input type="radio"/> | <input type="radio"/> | <input type="radio"/> | <input type="radio"/> |
| 18 | <input type="radio"/> | <input type="radio"/> | <input type="radio"/> | <input type="radio"/> | <input type="radio"/> |
| 19 | <input type="radio"/> | <input type="radio"/> | <input type="radio"/> | <input type="radio"/> | <input type="radio"/> |
| 20 | <input type="radio"/> | <input type="radio"/> | <input type="radio"/> | <input type="radio"/> | <input type="radio"/> |



* S Q 3 5 N 5 0 2 0 3 *

[BLANK PAGE]



SECTION 2 — 90 marks

Attempt ALL questions

MARKS

DO NOT
WRITE IN
THIS
MARGIN

1. (a) A student sets up the following circuit.

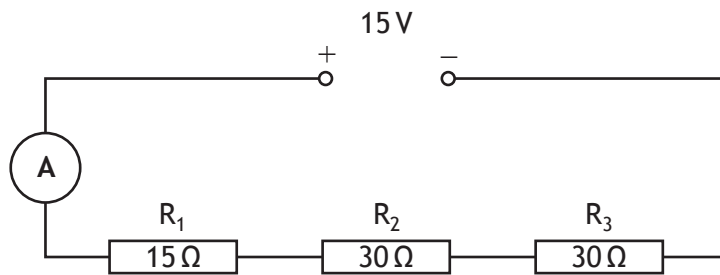

- (i) Calculate the current in the circuit.

4

Space for working and answer

- (ii) Calculate the potential difference across resistor R₁.

3

Space for working and answer



1. (continued)

(b) The circuit is now rearranged as shown below.

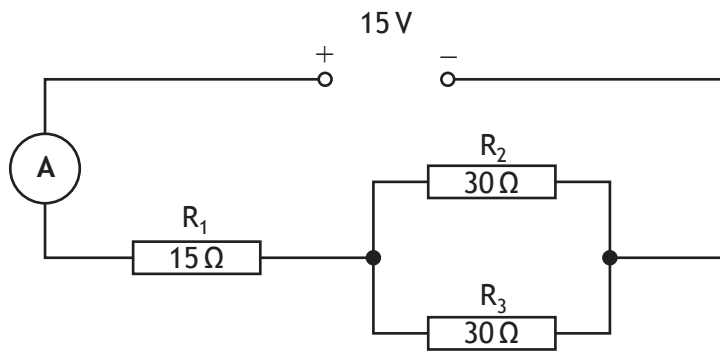

State how the reading on the ammeter compares to your answer in (a)(i). **5**

Justify your answer by calculation.

Space for working and answer

Total marks 12

2. A technician sets up a water bath for an experiment to study fermentation at different temperatures.

The rating plate of the water bath is shown.

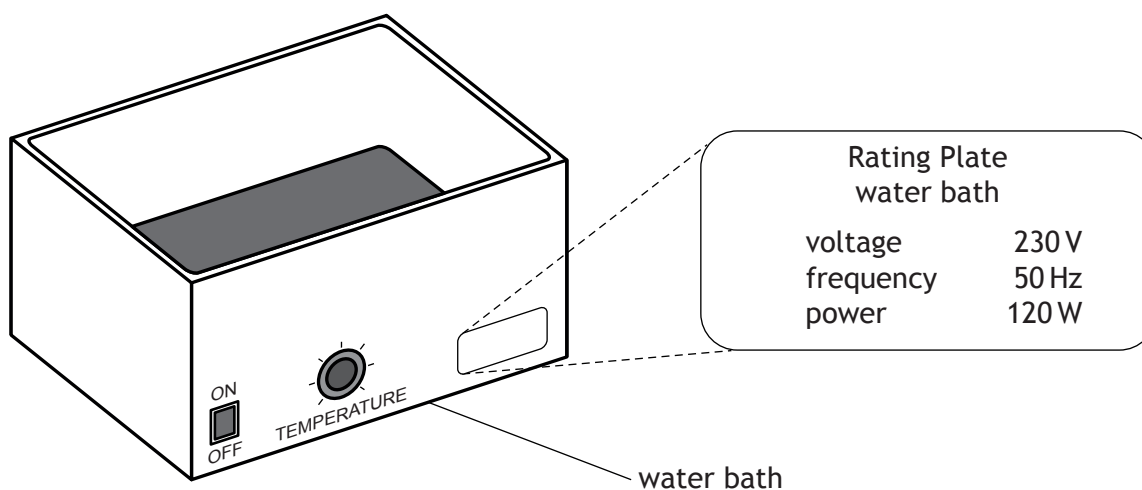

- (a) The water bath contains 3.0 kg of water at an initial temperature of 15 °C.

The specific heat capacity of the water is 4180 J kg⁻¹ °C⁻¹.

Calculate the energy required to raise the temperature of the water to 45 °C.

3

Space for working and answer

- (b) Calculate the minimum time required to heat the water to 45 °C.

3

Space for working and answer



MARKS DO NOT
WRITE IN
THIS
MARGIN

2. (continued)

(c) In practice it requires more time than calculated to heat the water.

(i) Explain why more time is required.

1

(ii) Suggest one way of reducing this additional time.

1

Total marks 8



* S Q 3 5 N 5 0 2 0 8 *

3. Extreme temperatures have been known to cause some electricity supply pylons to collapse.

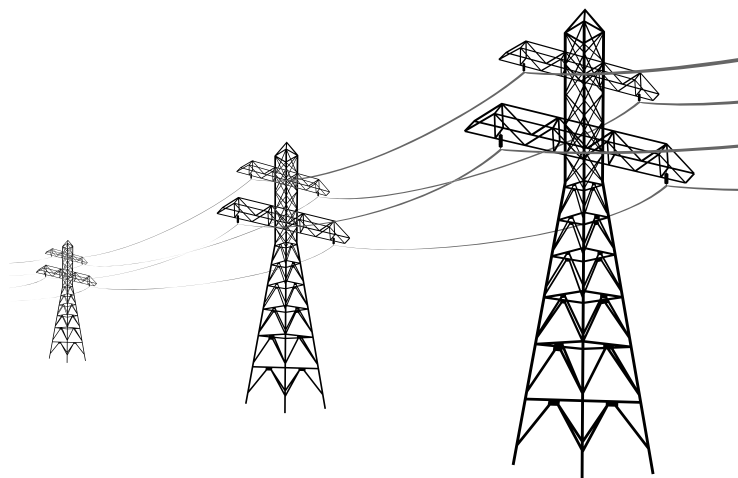

Using your knowledge of physics, comment on why this happens.

3



4. Architects need to know how well different materials insulate buildings. This can be determined using U -values.

The U -value is defined as the rate at which heat energy is transferred through one square metre of building material when the temperature difference is one degree Celsius.

The rate of heat transfer through a material can be determined using:

$$\text{rate of heat transfer} = U\text{-value} \times \text{area} \times \text{difference in temperature}$$

The tables below give information for two houses.

House P



| House P | U -value ($\text{W m}^{-2} \text{ } ^\circ\text{C}^{-1}$) | Total area (m^2) |
|-----------------------|--|-----------------------------|
| Uninsulated roof | 2.0 | 150 |
| Cavity walls | 1.9 | 300 |
| Single glazed windows | 5.6 | 50 |

House Q



| House Q | U -value ($\text{W m}^{-2} \text{ } ^\circ\text{C}^{-1}$) | Total area (m^2) |
|-----------------------|--|-----------------------------|
| Insulated roof | 0.5 | 150 |
| Filled cavity walls | 0.6 | 500 |
| Double glazed windows | 2.8 | 80 |



4. (continued)

- (a) Complete the sentence below by circling the correct answer.

1

The $\left\{ \begin{array}{l} \text{higher} \\ \text{lower} \end{array} \right\}$ the U-value, the better the material is as a heat insulator.

- (b) Show by calculation that house P has the highest rate of heat transfer through the walls when the outside temperature is 2 °C and the inside temperature in both houses is 18 °C.

4

Space for working and answer



4. (continued)

- (c) Glass transmits infrared radiation and visible light. The percentage transmitted depends on the type and thickness of the glass. The data from tests on two different types of glass is displayed in the graph below.

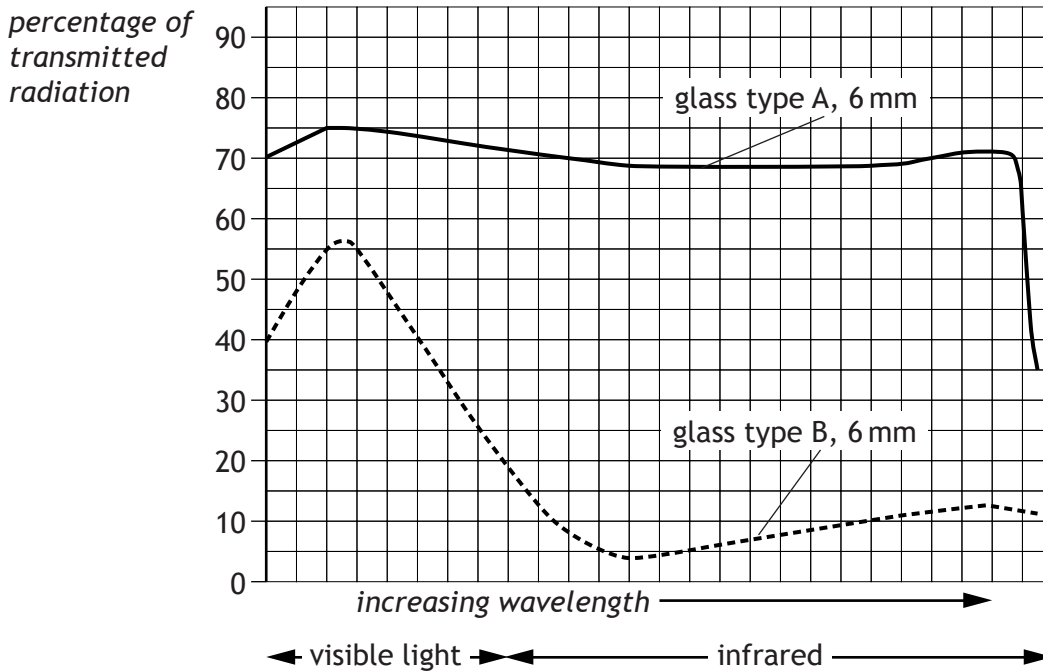

A glass conservatory is being built on house Q. The homeowner wants the inside of the conservatory to remain as cool as possible throughout the summer.

Using information from the graph, explain which type of glass should be used.

2

Total marks 7

5. A pair of neutron stars which orbit one another will over time move closer together and eventually join.

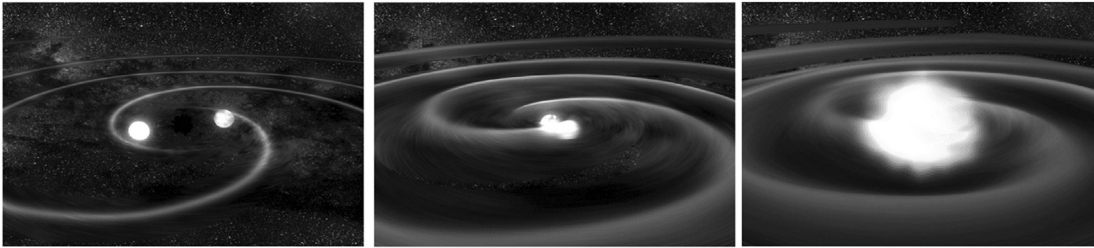

Astronomers believe that as the neutron stars move closer, they emit energy in the form of gravitational waves. It is predicted that gravitational wave detectors will produce the graphs shown.

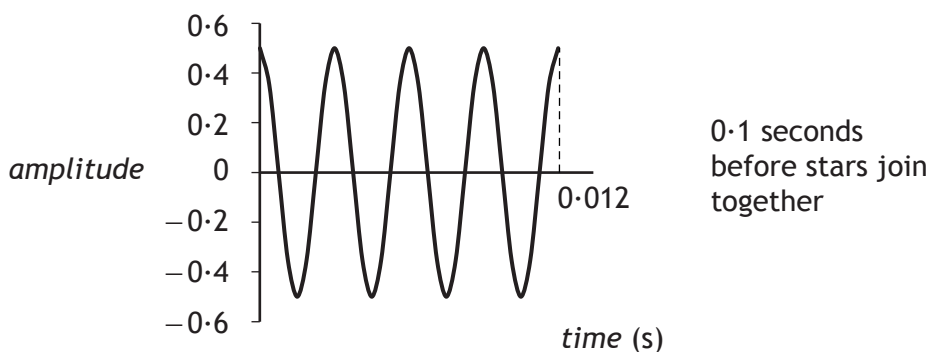
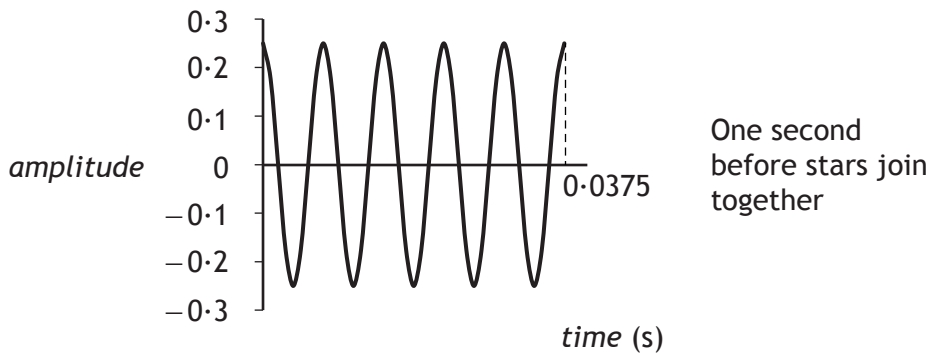
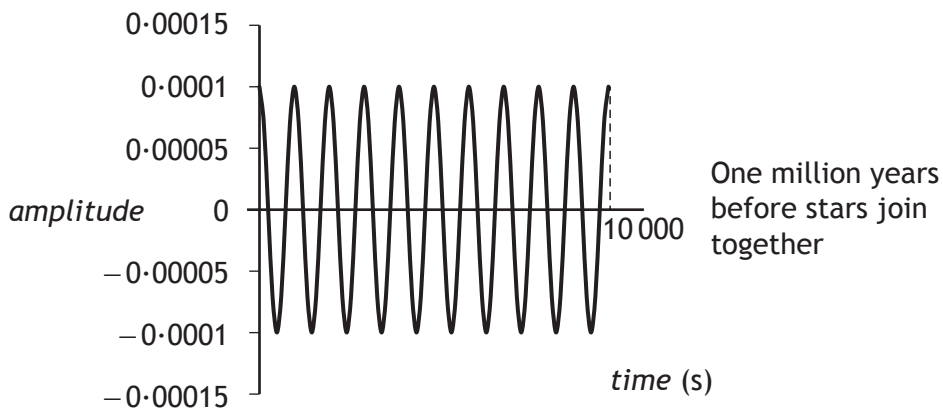

5. (continued)

- (a) Use the graphs to complete the following table. The first row has already been completed.

4

| <i>Time before the stars join</i> | <i>Period of gravitational waves (s)</i> | <i>Frequency of gravitational waves (Hz)</i> |
|-----------------------------------|--|--|
| 1 million years | 1000 | 0.001 |
| 1 second | | |
| 0.1 second | | |

Space for working

- (b) State what happens to the frequency of the gravitational waves as the neutron stars move closer together.

1

- (c) The orbital speed, in metres per second, of the rotating neutron stars is given by the equation:

$$v = \frac{2\pi R}{T}$$

where T is the orbital period in seconds and R is half the distance between the stars in metres.

Calculate the orbital speed of the neutron stars when they are 340 000 km apart and the orbital period is 1150 s.

2

Space for working and answer

Total marks 7



6. A water wave is diffracted when it passes through a gap in a barrier. The wavelength of the wave is 10 mm. The gap is less than 10 mm.

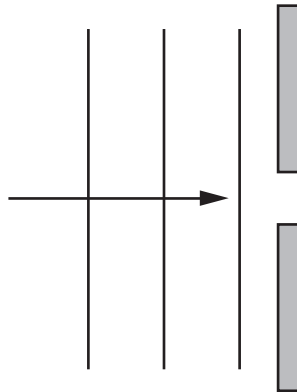

(a) Complete the diagram above to show the pattern of the wave to the right of the barrier. 2

(b) The diagram below represents the electromagnetic spectrum.

| | | | | | | |
|------------------|----------|--------------------|---------------|-------------------|--------|-----------------|
| Radio & TV waves | A | Infrared radiation | Visible light | Ultraviolet light | X-rays | Gamma radiation |
|------------------|----------|--------------------|---------------|-------------------|--------|-----------------|

(i) Identify radiation A. 1

(ii) Apart from diffraction, state one property that all electromagnetic waves have in common. 1

Total marks 4

7. Trees continually absorb carbon-14 when they are alive. When a tree dies the carbon-14 contained in its wood is not replaced. Carbon-14 is radioactive and decays by beta emission.

- (a) Following the tree's death, the activity of the carbon-14 within a **25 mg** sample of its wood changes as shown.

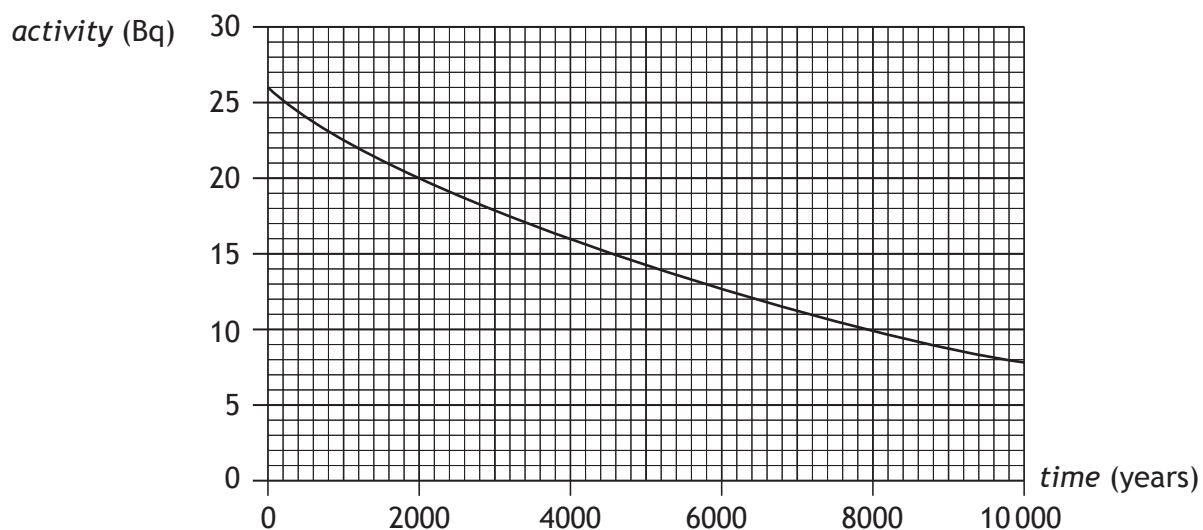

- (i) Use the graph to determine the half-life of carbon-14. 2

- (ii) Calculate the time taken for the activity of this sample of carbon-14 to fall to 6.5 Bq. 3

Space for working and answer



MARKS

DO NOT
WRITE IN
THIS
MARGIN

7. (a) (continued)

- (iii) During an archaeological dig, a 125 mg sample of the same type of wood was obtained. The activity of this sample was 40 Bq.

Estimate the age of this sample.

3

Space for working and answer

- (b) Explain why this method could not be used to estimate the age of a tree that died 100 years ago.

1

Total marks 9



* S Q 3 5 N 5 0 2 1 7 *

8. A technician uses a radioactive source to investigate the effect of gamma rays on biological tissue.



- (a) State what is meant by the term *gamma rays*. 1
- (b) The wavelength of a gamma ray is 6.0×10^{-13} m.
Calculate the frequency of the gamma ray. 3
Space for working and answer
- (c) In one experiment, a biological tissue sample of mass 0.10 kg receives an absorbed dose of $50 \mu\text{Gy}$.
Calculate the energy absorbed by the tissue. 3
Space for working and answer





8. (continued)

- (d) The radioactive source must be stored in a lead-lined container.
Explain why a lead-lined container should be used.

MARKS

DO NOT
WRITE IN
THIS
MARGIN

1

Total marks 8



* S Q 3 5 N 5 0 2 1 9 *

9. An aircraft is making a journey between two airports. A graph of the aircraft's velocity during take-off is shown below.

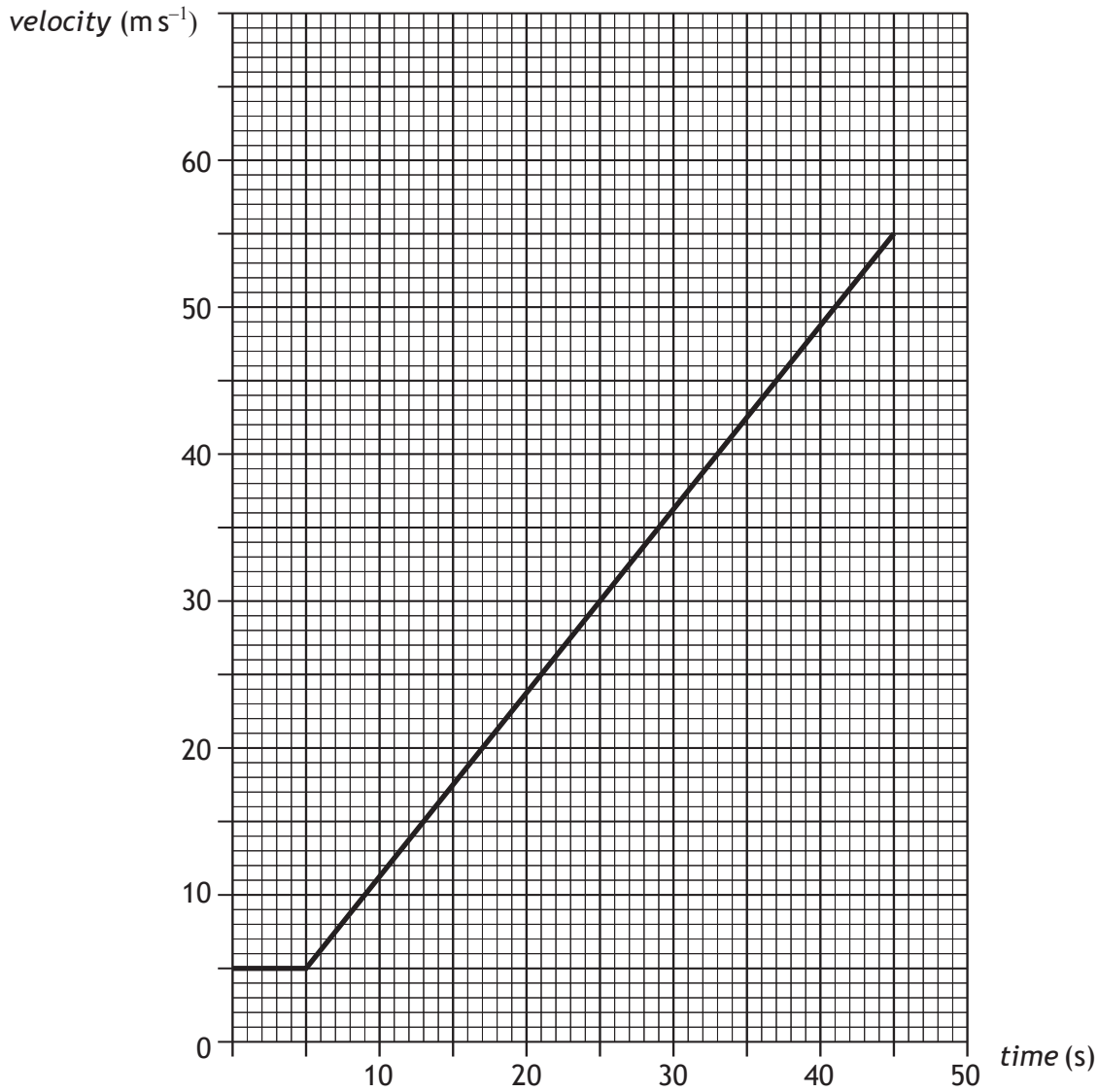

(a) Calculate the acceleration during take-off.

3

Space for working and answer



* S Q 3 5 N 5 0 2 2 0 *

9. (continued)

- (b) (i) During flight, the aircraft is travelling at a velocity of 150 m s^{-1} due north and then encounters a crosswind of 40 m s^{-1} due east.

By scale diagram, or otherwise, determine the resultant velocity of the aircraft.

4

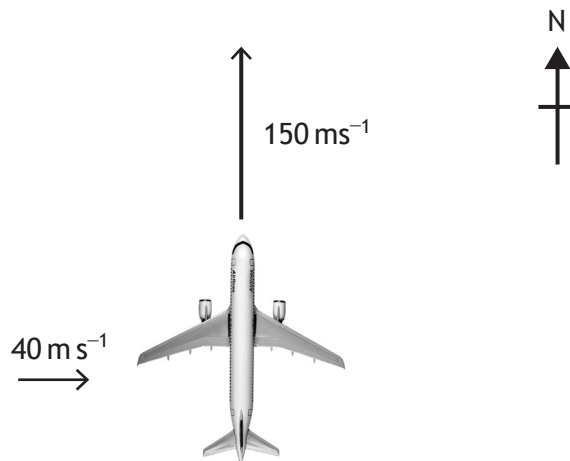

Space for working and answer



MARKS

DO NOT
WRITE IN
THIS
MARGIN

9. (b) (continued)

(ii) Describe what action the pilot could take to ensure that the aircraft remains travelling north at 150 m s^{-1} .

2

(c) The aircraft arrives at the destination airport.

This airport has three runways of different lengths to accommodate different sizes of aircraft.

Explain why larger aircraft require a much longer runway to land safely. 2

Total marks 11



* S Q 3 5 N 5 0 2 2 2 *

10. The Soyuz Spacecraft is used to transport astronauts to the International Space Station (ISS). The spacecraft contains three parts that are launched together.

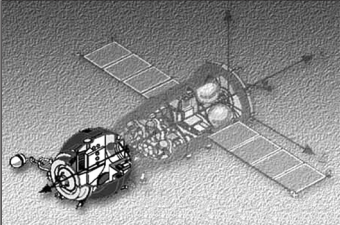
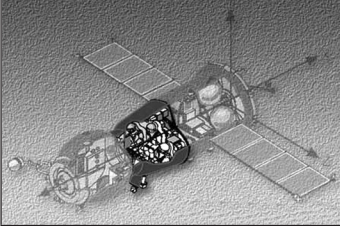
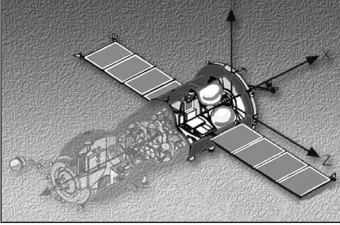
| | <i>Part</i> | <i>Mass (kg)</i> |
|--|--|------------------|
|  | Orbital Module | 1300 |
|  | Descent Module (including astronauts) | 2950 |
|  | Instrumentation/ Propulsion Module | 2900 |

- (a) When the spacecraft leaves the ISS, its propulsion module produces a force of 1430 N.

Calculate the acceleration of the spacecraft as it leaves the ISS.

4

Space for working and answer



10. (continued)

- (b) On the return flight, the Orbital Module and the Instrumentation/ Propulsion Module are jettisoned. Instead of returning to Earth, they burn up in the atmosphere at a very high temperature.

Explain why these Modules burn up on re-entry into the atmosphere.

2

- (c) After the Descent Module has re-entered the atmosphere, its speed is dramatically reduced.

- (i) Four parachutes are used to slow the Module's rate of descent from 230 m s^{-1} to 80 m s^{-1} .

Explain, in terms of forces, how the parachutes reduce the speed of the Module.

2



10. (c) (continued)

- (ii) Just before touchdown, small engines fire on the bottom of the Module, slowing it down further. The work done by the engines is 80 kJ over a distance of 5 m.

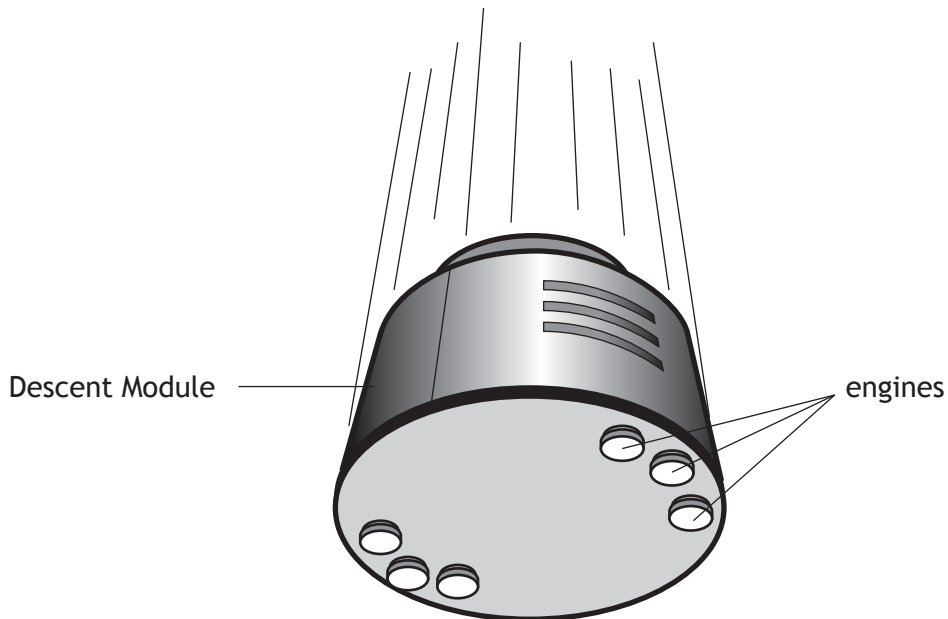

Calculate the force produced by the engines.

3

Space for working and answer

Total marks 11



11. Read the passage below and answer the questions that follow.

**Dragonfish nebula conceals
giant cluster of young stars**



The Dragonfish nebula may contain the Milky Way's most massive cluster of young stars. Scientists from the University of Toronto found the first hint of the cluster in 2010 in the form of a big cloud of ionised gas 30000 light years from Earth. They detected the gas from its microwave emissions, suspecting that radiation from massive stars nearby had ionised the gas.

Now the scientists have identified a cluster of 400 massive stars in the heart of the gas cloud using images from an infrared telescope. The cluster probably contains more stars which are too small and dim to detect.

The surrounding cloud of ionised gas is producing more microwaves than the clouds around other star clusters in our galaxy. This suggests that the Dragonfish nebula contains the brightest and most massive young cluster discovered so far, with a total mass of around 100000 times the mass of the Sun.

(a) Name the galaxy mentioned in the passage.

1

(b) Show that the Dragonfish nebula is approximately 2.84×10^{20} m away from Earth.

3

Space for working and answer



11. (continued)

(c) Complete the sentence by circling the correct words.

Compared to infrared radiation, microwaves have a $\left\{ \begin{array}{l} \text{longer} \\ \text{shorter} \end{array} \right\}$
wavelength which means they have a $\left\{ \begin{array}{l} \text{higher} \\ \text{lower} \end{array} \right\}$ frequency.

1

(d) A line spectrum from a nebula is shown below.



spectral lines from gases in the nebula



nitrogen

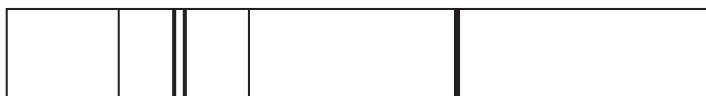

helium

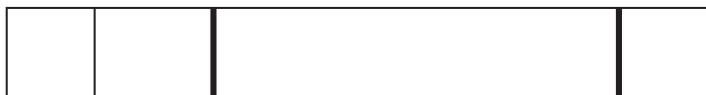

hydrogen

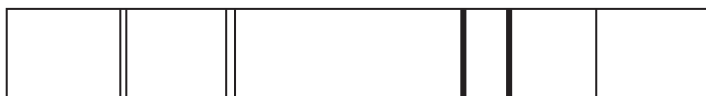

krypton

Identify the elements present in the nebula.

2

Total marks 7



12. In October 2012, a skydiver jumped from a balloon at a height of 39 km above the surface of the Earth.

He became the first person to jump from this height.

He also became the first human to fall at speeds higher than the speed of sound in air.



Using your knowledge of physics, comment on the challenges faced by the skydiver when making this jump.

3

Space for answer

[END OF SPECIMEN QUESTION PAPER]



* S Q 3 5 N 5 0 2 2 8 *

ADDITIONAL SPACE FOR ROUGH WORKING AND ANSWERS

MARKS

DO NOT
WRITE IN
THIS
MARGIN



* S Q 3 5 N 5 0 2 2 9 *

ADDITIONAL SPACE FOR ROUGH WORKING AND ANSWERS

MARKS

DO NOT
WRITE IN
THIS
MARGIN



* S Q 3 5 N 5 0 2 3 0 *

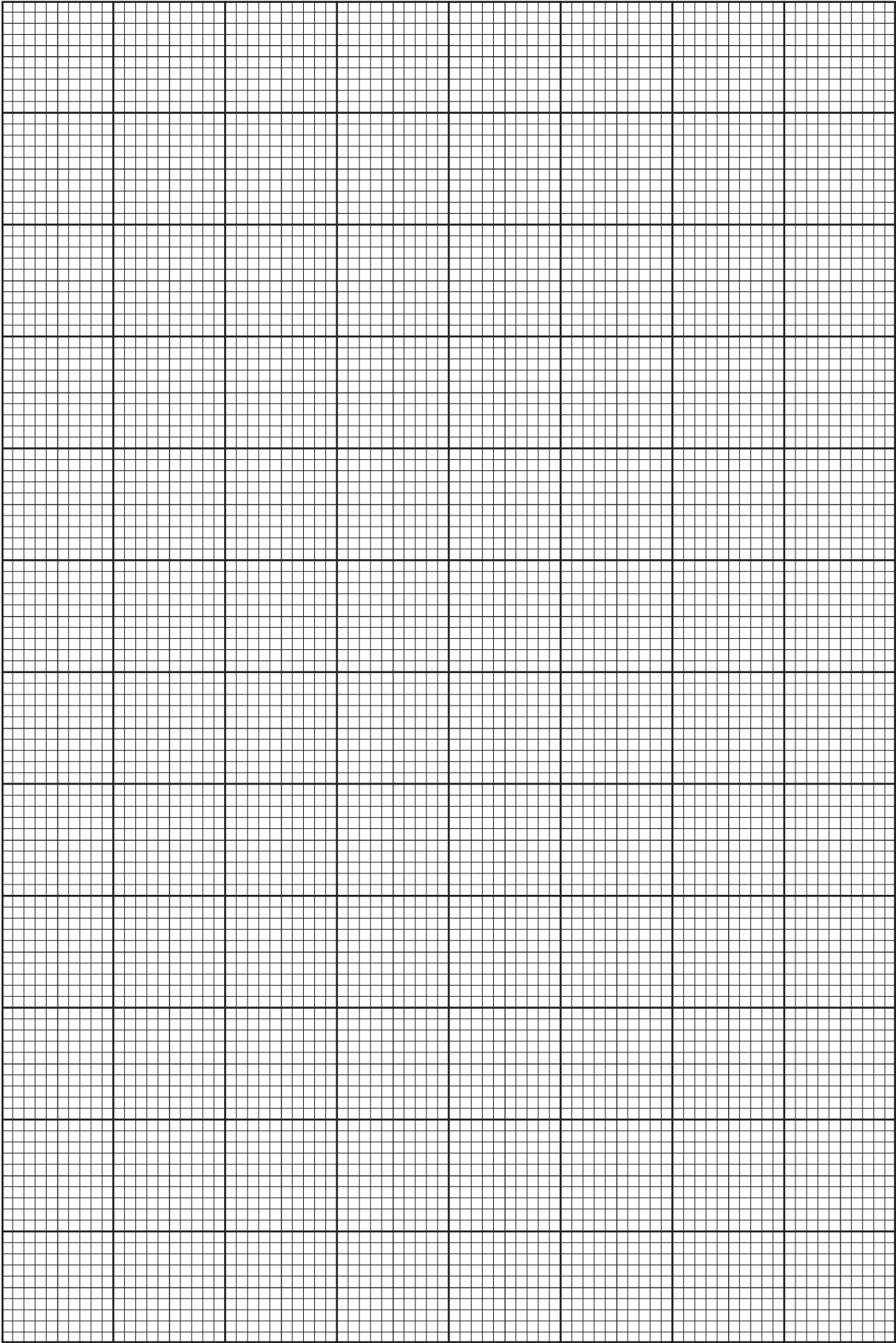

* S Q 3 5 N 5 0 2 3 1 *

Acknowledgement of Copyright

Section 2 Question 11 Extract is adapted from an article titled “Dragonfish nebula conceals giant star cluster” taken from the New Scientist Magazine, 26 January 2011. Reproduced by kind permission of New Scientist.



National
Qualifications
SPECIMEN ONLY

SQ29/N5/01

Physics

Marking Instructions

These Marking Instructions have been provided to show how SQA would mark this Specimen Question Paper.

The information in this publication may be reproduced to support SQA qualifications only on a non-commercial basis. If it is to be used for any other purpose, written permission must be obtained from SQA's Marketing team on marketing@sqa.org.uk.

Where the publication includes materials from sources other than SQA (ie secondary copyright), this material should only be reproduced for the purposes of examination or assessment. If it needs to be reproduced for any other purpose it is the user's responsibility to obtain the necessary copyright clearance.

Part One: General Marking Principles for National 5 Physics

This information is provided to help you understand the general principles you must apply when marking candidate responses to questions in this Paper. These principles must be read in conjunction with the specific Marking Instructions for each question. The marking schemes are written to assist in determining the “minimal acceptable answer” rather than listing every possible correct and incorrect answer.

- (a) Marks for each candidate response must always be assigned in line with these general marking principles and the specific Marking Instructions for the relevant question.
- (b) Marking should always be positive, ie marks should be awarded for what is correct and not deducted for errors or omissions.
- (c) There are no half marks awarded.
- (d) Where a candidate makes an error at an early stage in a multi-stage calculation, credit should be given for correct follow-on working in subsequent stages if allowed by the Marking Instructions. The same principle should be applied in questions which require several stages of non-mathematical reasoning.
- (e) Unless a numerical question specifically requires evidence of working to be shown, full marks should be awarded for a correct final answer (including unit) on its own.
- (f) Where a wrong answer (for which no credit has been given) is carried forward to another step, credit will be given provided the end result is used correctly.
- (g) Credit should be given where a diagram or sketch conveys correctly the response required by the question. It will usually require clear and correct labels (including the use of standard symbols).
- (h) Mark to be awarded when a candidate writes down the relevant formula but does not substitute any values into the formula.
- (i) Mark to be awarded for correct substitution.
- (j) Mark should be awarded for non-standard symbols where the symbols are defined and the relationship is correct, or where the substitution shows that the relationship used is correct. This must be clear and unambiguous.
- (k) Rounding to an expected number of significant figures, the mark can be awarded for answers which have up to two figures more or one figure less than the expected answer.
- (l) Marks should be awarded regardless of spelling as long as the meaning is unambiguous.

(m) Marking in calculations

Question:

The current in a resistor is 1.5 amperes when the potential difference across it is 7.5 volts. Calculate the resistance of the resistor. (3 marks)

| Candidate answer | Mark + Comment |
|--|---|
| 1. $V = IR$ | 1 mark, formula |
| $7.5 = 1.5R$ | 1 mark, substitution |
| $R = 5.0 \Omega$ | 1 mark, correct answer |
| 2. 5.0Ω | 3 marks: correct answer |
| 3. 5.0 | 2 marks: unit missing |
| 4. 4.0Ω | 0 marks: no evidence, wrong answer |
| 5. $__ \Omega$ | 0 marks: no working or final answer |
| 6. $R = \frac{V}{I} = \frac{7.5}{1.5} = 4.0 \Omega$ | 2 marks: arithmetic error |
| 7. $R = \frac{V}{I} = 4.0 \Omega$ | 1 mark: formula only |
| 8. $R = \frac{V}{I} = ____ \Omega$ | 1 mark: formula only |
| 9. $R = \frac{V}{I} = \frac{7.5}{1.5} = ____ \Omega$ | 2 marks: formula & subs, no final answer |
| 10. $R = \frac{V}{I} = \frac{7.5}{1.5} = 4.0$ | 2 marks: formula & subs, wrong answer |
| 11. $R = \frac{V}{I} = \frac{1.5}{7.5} = 5.0 \Omega$ | 1 mark: formula but wrong substitution |
| 12. $R = \frac{V}{I} = \frac{75}{1.5} = 5.0 \Omega$ | 1 mark: formula but wrong substitution |
| 13. $R = \frac{I}{V} = \frac{7.5}{1.5} = 5.0 \Omega$ | 0 marks: wrong formula |
| 14. $V = IR$ $7.5 = 1.5 \times R$ $R = 0.2 \Omega$ | 2 marks: formula & subs, arithmetic error |
| 15. $V = IR$ $R = \frac{I}{V} = \frac{1.5}{7.5} = 0.2 \Omega$ | 1 mark: formula only wrong rearrangement of symbols |

Part Two: Marking Instructions for each question

Section 1

| Question | Response | Mark |
|-----------------|-----------------|-------------|
| 1 | C | 1 |
| 2 | B | 1 |
| 3 | C | 1 |
| 4 | D | 1 |
| 5 | C | 1 |
| 6 | C | 1 |
| 7 | E | 1 |
| 8 | B | 1 |
| 9 | C | 1 |
| 10 | C | 1 |
| 11 | A | 1 |
| 12 | D | 1 |
| 13 | E | 1 |
| 14 | E | 1 |
| 15 | B | 1 |
| 16 | D | 1 |
| 17 | A | 1 |
| 18 | D | 1 |
| 19 | D | 1 |
| 20 | A | 1 |

Section 2

| Question | | | Expected response | Max Mark | Additional guidance |
|----------|---|----|--|----------|---|
| 1 | a | i | $R_t = R_1 + R_2 + R_3$ $= (30 + 30 + 15) = 75 (\Omega)$ (1) $I = \frac{V}{R}$ (1) $= \frac{15}{75}$ (1) $= 0.2 \text{ A}$ (1) | 4 | For calculation in $I = \frac{V}{R}$ use answer consistent with intermediate answer for R_t |
| 1 | a | ii | $V = IR$ (1) $= 15 \times 0.2$ (1) $= 3 \text{ V}$ (1) | 3 | or consistent with (a)(i) |
| 1 | b | | Total circuit resistance is less so the reading on the ammeter will increase. (1) Resistors in parallel: $\frac{1}{R_t} = \frac{1}{R_1} + \frac{1}{R_2}$ (1) $\frac{1}{R_t} = \frac{1}{30} + \frac{1}{30}$ (1) $R_t = 15 (\Omega)$ (1) Total resistance = $(15 + 15) = 30 \Omega$ (1) | 5 | Alternative: Reading on the ammeter will increase $I = \frac{V}{R}$ $= \frac{15}{30}$ $= 0.2 \text{ A}$ |
| 2 | a | | $E_h = cm\Delta T$ (1) $= 4180 \times 3 \times 30$ (1) $= 376\,200 \text{ J}$ (1) | 3 | |
| 2 | b | | $E_h = Pt$ (1) $376\,200 = 120 \times t$ (1) $t = 3135 \text{ s}$ (1) | 3 | |
| 2 | c | i | Energy loss to surroundings | 1 | |
| 2 | c | ii | Top open – use a cover/lid etc | 1 | |

| | | | |
|---|--|--|--|
| 3 | | <p>Demonstrates no understanding 0 marks</p> <p>Demonstrates limited understanding 1 marks</p> <p>Demonstrates reasonable understanding 2 marks</p> <p>Demonstrates good understanding 3 marks</p> <p>This is an open-ended question.</p> <p>1 mark: The student has demonstrated a limited understanding of the physics involved. The student has made some statement(s) which is/are relevant to the situation, showing that at least a little of the physics within the problem is understood.</p> <p>2 marks: The student has demonstrated a reasonable understanding of the physics involved. The student makes some statement(s) which is/are relevant to the situation, showing that the problem is understood.</p> <p>3 marks: The maximum available mark would be awarded to a student who has demonstrated a good understanding of the physics involved. The student shows a good comprehension of the physics of the situation and has provided a logically correct answer to the question posed. This type of response might include a statement of the principles involved, a relationship or an equation, and the application of these to respond to the problem. This does not mean the answer has to be what might be termed an “excellent” answer or a “complete” one.</p> | <p>3 Open-ended question: a variety of physics arguments can be used to answer this question.</p> <p>Marks are awarded on the basis of whether the answer overall demonstrates “no”, “limited”, “reasonable” or “good” understanding.</p> |
|---|--|--|--|

| 4 | a | | Lower | 1 | | | | | | | | | | | | | |
|-----------------------------------|--|--|---|-----------------------------------|--|--|-----------------|------|-------|----------|------------|---------|------------|---------------------------|-----------------------------|---|---|
| 4 | b | | House P: (rate of heat transfer) $= 1.9 \times 300 \times 16$ (1) $= 9120 \text{ W}$ (1) House Q: (rate of heat transfer) $= 0.6 \times 500 \times 16$ (1) $= 4800 \text{ W}$ (1) | 4 | | | | | | | | | | | | | |
| 4 | c | | Type B (1) Type B glass transmits less infrared radiation than Type A glass. (1) | 2 | | | | | | | | | | | | | |
| 5 | a | | <table border="1"> <thead> <tr> <th><i>Time before the stars join</i></th> <th><i>Period of gravitational waves (s)</i></th> <th><i>Frequency of gravitational waves (Hz)</i></th> </tr> </thead> <tbody> <tr> <td>1 million years</td> <td>1000</td> <td>0.001</td> </tr> <tr> <td>1 second</td> <td>0.0075 (1)</td> <td>133 (1)</td> </tr> <tr> <td>0.1 second</td> <td>0.003 (1) or 0.0030</td> <td>300 or (1) 330 or 333</td> </tr> </tbody> </table> | <i>Time before the stars join</i> | <i>Period of gravitational waves (s)</i> | <i>Frequency of gravitational waves (Hz)</i> | 1 million years | 1000 | 0.001 | 1 second | 0.0075 (1) | 133 (1) | 0.1 second | 0.003 (1) or 0.0030 | 300 or (1) 330 or 333 | 4 | 1 mark for each correct period. 1 mark for each correct frequency. If answers for period wrong, allow answers for frequency consistent with period answers. |
| <i>Time before the stars join</i> | <i>Period of gravitational waves (s)</i> | <i>Frequency of gravitational waves (Hz)</i> | | | | | | | | | | | | | | | |
| 1 million years | 1000 | 0.001 | | | | | | | | | | | | | | | |
| 1 second | 0.0075 (1) | 133 (1) | | | | | | | | | | | | | | | |
| 0.1 second | 0.003 (1) or 0.0030 | 300 or (1) 330 or 333 | | | | | | | | | | | | | | | |
| 5 | b | | The gravitational wave frequency increases. | 1 | No dotted line from part (a). | | | | | | | | | | | | |
| 5 | c | | $R = \frac{3.4 \times 10^8}{2} = 1.7 \times 10^8$ $v = \frac{2 \times \pi}{T} R$ $= \frac{2 \times \pi}{1150} \times 1.7 \times 10^8 \quad (1)$ $= 9.3 \times 10^5 \text{ ms}^{-1} \quad (1)$ | 2 | Equation is given so 1 mark for correct substitution. 1 mark for final answer including unit. | | | | | | | | | | | | |

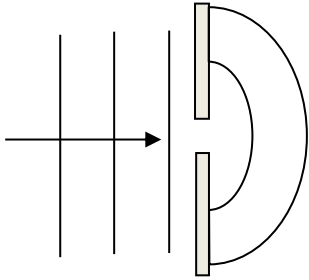
| | | | | | |
|---|---|-----|--|---|--|
| 6 | a | |  | 2 | Circular wavefronts (1) Wavelength after the gap is the same as before the gap. A minimum of two wavefronts must be drawn. (1) |
| | b | i | Microwaves | 1 | |
| 6 | b | ii | They all travel at the same speed through a vacuum OR in air. OR They all exhibit interference OR reflection OR refraction OR propagation. | 1 | |
| 7 | a | i | Identify 13 Bq as half of the initial activity. (1) Half-life is 5800 years. (1) | 2 | (Or choosing another activity value and halving it.) |
| 7 | a | ii | $26 \rightarrow 13 \rightarrow 6.5 = 2$ half-lives (1) total time = 2×5800 (1) $= 11\,600$ years (1) | 3 | Or consistent with (a)(i). |
| 7 | a | iii | Activity of 125 mg sample is 40 Bq. Activity of 8 mg of sample = $1/5$ OR $\frac{25}{125} \times 40$ (1) $= 8$ (Bq) (1) (From graph, 8 Bq is at 9800 years.) Sample is approximately 9800 years old. (1) | 3 | 1 mark for identifying $1/5$ (or $25/125$). 1 mark for calculating activity of 25 mg sample. 1 mark for selecting value from graph. |
| 7 | b | | The half-life of carbon 14 is 5800 years. For 100 years the very small reduction in the activity would be difficult to measure accurately. | 1 | |

| | | | | | |
|----------|---|--|---|----------|--|
| 8 | a | | Gamma rays are electromagnetic waves. | 1 | |
| 8 | b | | $f = \frac{v}{\lambda} \quad (1)$ $= \frac{3 \times 10^8}{6 \times 10^{-13}} \quad (1)$ $= 5 \times 10^{20} \text{ Hz} \quad (1)$ | 3 | |
| 8 | c | | $D = \frac{E}{m} \quad (1)$ $50 \times 10^{-6} = \frac{E}{0.1} \quad (1)$ $E = 5 \times 10^{-6} \text{ J} \quad (1)$ | 3 | |
| 8 | d | | Gamma rays are absorbed by the lead. | 1 | |

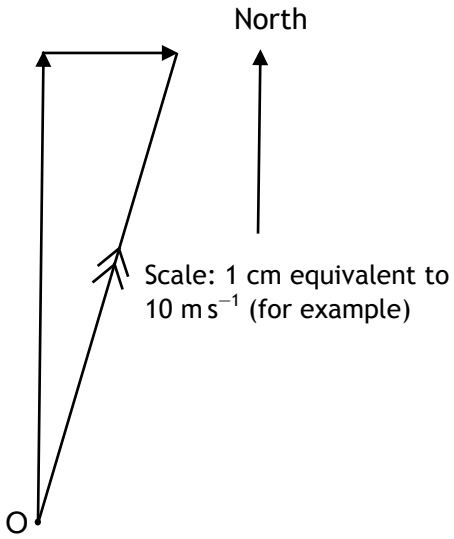
| | | | | |
|---|---|---|---|---|
| 9 | a | $a = \frac{v-u}{t} \quad (1)$ $= \frac{55-5}{40} \quad (1)$ $= 1.25 \text{ms}^{-2} \quad (1)$ | 3 | |
| 9 | b | <p data-bbox="320 450 344 483">i</p>  <p data-bbox="616 450 692 483">North</p> <p data-bbox="523 707 839 775">Scale: 1 cm equivalent to 10 m s⁻¹ (for example)</p> | 4 | <p data-bbox="975 439 1214 472">By scale diagram:</p> <p data-bbox="975 506 1385 573">1 mark for correct diagram to: scale, length and angle.</p> <p data-bbox="975 573 1437 674">1 mark for adding correctly showing resultant direction (arrow needed).</p> <p data-bbox="975 674 1326 741">1 mark for velocity within tolerance</p> <p data-bbox="975 741 1193 775">$v = 155 \pm 3 \text{ m s}^{-1}$</p> <p data-bbox="975 775 1453 842">1 mark for bearing within tolerance</p> <p data-bbox="975 842 1406 875">015 ± 2 (or 15 ± 2° East of North)</p> <p data-bbox="975 887 1174 920">By calculation:</p> <p data-bbox="975 920 1430 954">$v^2 = 150^2 + 40^2 \quad (1)$</p> <p data-bbox="1031 976 1430 1010">$= 155 \text{ m s}^{-1} \quad (1)$</p> <p data-bbox="975 1021 1430 1055">$\tan x = 0.27 \quad (1)$</p> <p data-bbox="975 1066 1430 1155">bearing = 015 (or 15° E of N) (1)</p> |
| 9 | b | <p data-bbox="320 1200 344 1234">ii</p> <p data-bbox="376 1200 839 1234">Change speed to 155 m s⁻¹ (1)</p> <p data-bbox="376 1234 839 1290">At bearing of 345 (or 15° West of North) (1)</p> | 2 | Or consistent with (b)(i) |
| 9 | c | <p data-bbox="376 1335 839 1402">aircraft has increased mass (1) so has reduced deceleration (1)</p> <p data-bbox="376 1435 416 1469">OR</p> <p data-bbox="376 1503 839 1536">aircraft takes longer to stop (1) so longer distance required (1)</p> | 2 | Or any other appropriate answer. |

| | | | | | |
|----|---|----|---|---|---|
| 10 | a | | <p>Total mass = 1300 + 2950 + 2900 = 7150 kg (1)</p> <p>$F = ma$ (1)</p> <p>$1430 = 7150 \times a$ (1)</p> <p>$a = 0.2 \text{ m s}^{-2}$ (1)</p> | 4 | |
| 10 | b | | <p>(force of) friction (is created) on the surface of the modules (1)</p> <p>causes heat energy to be produced (1)</p> | 2 | |
| 10 | c | i | <p>upward force is increased (by parachutes) (1)</p> <p>producing an unbalanced force upward (1)</p> | 2 | |
| 10 | c | ii | <p>$E_w = Fd$ (1)</p> <p>$80\,000 = F \times 5$ (1)</p> <p>$F = 16\,000 \text{ N}$ (1)</p> | 3 | |
| 11 | a | | Milky Way | 1 | |
| 11 | b | | <p>$d = vt$ (1)</p> <p>$= 3 \times 10^8 \times (365 \times 24 \times 60 \times 60)$ $\times 30000$ (1) + (1)</p> <p>$= 2.84 \times 10^{20} \text{ m}$</p> | 3 | <p>1 mark for initial equation</p> <p>1 data mark awarded for obtaining value for speed of light from Data Sheet</p> <p>1 mark for correct substitution of time</p> |
| 11 | c | | <p>Longer</p> <p>Lower</p> | 1 | 1 mark for both correct |
| 11 | d | | <p>Helium (1)</p> <p>Hydrogen (1)</p> | 2 | |

| | | | |
|----|--|---|---|
| 12 | | <p>Demonstrates no Understanding (0)</p> <p>Demonstrates limited understanding (1)</p> <p>Demonstrates reasonable understanding (2)</p> <p>Demonstrates good understanding (3)</p> <p>This is an open ended question. 1 mark: The student has demonstrated a limited understanding of the physics involved. The student has made some statement(s) which is/are relevant to the situation, showing that at least a little of the physics within the problem is understood.</p> <p>2 marks: The student has demonstrated a reasonable understanding of the physics involved. The student makes some statement(s) which is/are relevant to the situation, showing that the problem is understood.</p> <p>3 marks: The maximum available mark would be awarded to a student who has demonstrated a good understanding of the physics involved. The student shows a good comprehension of the physics of the situation and has provided a logically correct answer to the question posed. This type of response might include a statement of the principles involved, a relationship or an equation, and the application of these to respond to the problem. This does not mean the answer has to be what might be termed an “excellent” answer or a “complete” one.</p> | <p>3</p> <p>Open ended question – a variety of physics arguments can be used to answer this question.</p> <p>Marks are awarded on the basis of whether the answer overall demonstrates “no”, “limited”, “reasonable” or “good” understanding.</p> |
|----|--|---|---|

[END OF SPECIMEN MARKING INSTRUCTIONS]