

# X069/301

---

NATIONAL  
QUALIFICATIONS  
2011

MONDAY, 23 MAY  
1.00 PM – 3.30 PM

PHYSICS  
HIGHER

## Read Carefully

Reference may be made to the Physics Data Booklet.

- 1 All questions should be attempted.

### Section A (questions 1 to 20)

- 2 Check that the answer sheet is for Physics Higher (Section A).
- 3 For this section of the examination you must use an **HB pencil** and, where necessary, an eraser.
- 4 Check that the answer sheet you have been given has **your name, date of birth, SCN** (Scottish Candidate Number) and **Centre Name** printed on it.  
Do not change any of these details.
- 5 If any of this information is wrong, tell the Invigilator immediately.
- 6 If this information is correct, **print** your name and seat number in the boxes provided.
- 7 There is **only one correct** answer to each question.
- 8 Any rough working should be done on the question paper or the rough working sheet, **not** on your answer sheet.
- 9 At the end of the exam, put the **answer sheet for Section A inside the front cover of your answer book**.
- 10 Instructions as to how to record your answers to questions 1–20 are given on page three.

### Section B (questions 21 to 30)

- 11 Answer the questions numbered 21 to 30 in the answer book provided.
- 12 **All answers must be written clearly and legibly in ink.**
- 13 Fill in the details on the front of the answer book.
- 14 Enter the question number clearly in the margin of the answer book beside each of your answers to questions 21 to 30.
- 15 Care should be taken to give an appropriate number of significant figures in the final answers to calculations.
- 16 Where additional paper, eg square ruled paper, is used, write your name and SCN (Scottish Candidate Number) on it and place it inside the front cover of your answer booklet.



**DATA SHEET**  
COMMON PHYSICAL QUANTITIES

| <i>Quantity</i>                        | <i>Symbol</i> | <i>Value</i>                        | <i>Quantity</i>  | <i>Symbol</i> | <i>Value</i>                       |
|--|---------------|-------------------------------------|------------------|---------------|------------------------------------|
| Speed of light in vacuum               | $c$           | $3.00 \times 10^8 \text{ m s}^{-1}$ | Mass of electron | $m_e$         | $9.11 \times 10^{-31} \text{ kg}$  |
| Magnitude of the charge on an electron | $e$           | $1.60 \times 10^{-19} \text{ C}$    | Mass of neutron  | $m_n$         | $1.675 \times 10^{-27} \text{ kg}$ |
| Gravitational acceleration on Earth    | $g$           | $9.8 \text{ m s}^{-2}$              | Mass of proton   | $m_p$         | $1.673 \times 10^{-27} \text{ kg}$ |
| Planck's constant                      | $h$           | $6.63 \times 10^{-34} \text{ J s}$  |                  |               |                                    |

**REFRACTIVE INDICES**

The refractive indices refer to sodium light of wavelength 589 nm and to substances at a temperature of 273 K.

| <i>Substance</i> | <i>Refractive index</i> | <i>Substance</i> | <i>Refractive index</i> |
|------------------|-------------------------|------------------|-------------------------|
| Diamond          | 2.42                    | Water            | 1.33                    |
| Crown glass      | 1.50                    | Air              | 1.00                    |

**SPECTRAL LINES**

| <i>Element</i> | <i>Wavelength/nm</i> | <i>Colour</i> | <i>Element</i> | <i>Wavelength/nm</i> | <i>Colour</i> |
|----------------|----------------------|---------------|----------------|----------------------|---------------|
| Hydrogen       | 656                  | Red           | Cadmium        | 644                  | Red           |
|                | 486                  | Blue-green    |                | 509                  | Green         |
|                | 434                  | Blue-violet   |                | 480                  | Blue          |
|                | 410                  | Violet        | <i>Lasers</i>  |                      |               |
|                | 397                  | Ultraviolet   | <i>Element</i> | <i>Wavelength/nm</i> | <i>Colour</i> |
|                | 389                  | Ultraviolet   | Carbon dioxide | 9550 }<br>10590 }    | Infrared      |
| Sodium         | 589                  | Yellow        | Helium-neon    | 633                  | Red           |

**PROPERTIES OF SELECTED MATERIALS**

| <i>Substance</i> | <i>Density/kg m<sup>-3</sup></i> | <i>Melting Point/K</i> | <i>Boiling Point/K</i> |
|------------------|----------------------------------|------------------------|------------------------|
| Aluminium        | $2.70 \times 10^3$               | 933                    | 2623                   |
| Copper           | $8.96 \times 10^3$               | 1357                   | 2853                   |
| Ice              | $9.20 \times 10^2$               | 273                    | ....                   |
| Sea Water        | $1.02 \times 10^3$               | 264                    | 377                    |
| Water            | $1.00 \times 10^3$               | 273                    | 373                    |
| Air              | 1.29                             | ....                   | ....                   |
| Hydrogen         | $9.0 \times 10^{-2}$             | 14                     | 20                     |

The gas densities refer to a temperature of 273 K and a pressure of  $1.01 \times 10^5 \text{ Pa}$ .

## SECTION A

For questions 1 to 20 in this section of the paper the answer to each question is either A, B, C, D or E. Decide what your answer is, then, using your pencil, put a horizontal line in the space provided—see the example below.

### EXAMPLE

The energy unit measured by the electricity meter in your home is the

- A kilowatt-hour
- B ampere
- C watt
- D coulomb
- E volt.

The correct answer is **A**—kilowatt-hour. The answer **A** has been clearly marked in **pencil** with a horizontal line (see below).

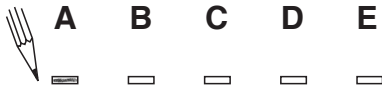

### Changing an answer

If you decide to change your answer, carefully erase your first answer and, using your pencil, fill in the answer you want. The answer below has been changed to **E**.



[Turn over

SECTION A

Answer questions 1–20 on the answer sheet.

1. Which of the following is a scalar quantity?

- A velocity
- B acceleration
- C mass
- D force
- E momentum

2. A vehicle is travelling in a straight line. Graphs of velocity and acceleration against time are shown.

Which pair of graphs could represent the motion of the vehicle?

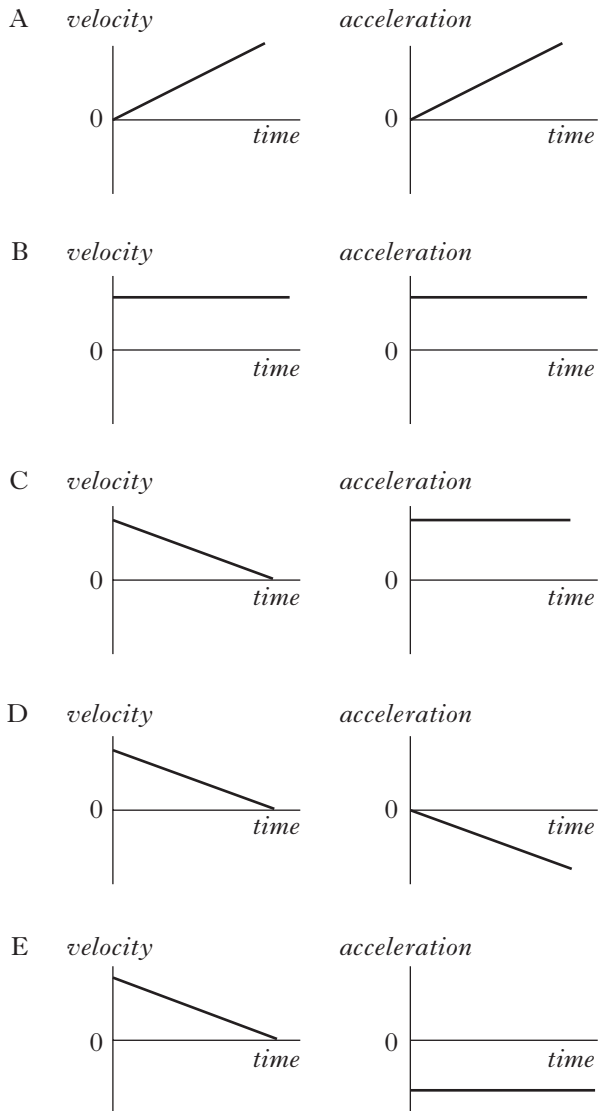

3. A car of mass 1200 kg pulls a horsebox of mass 700 kg along a straight, horizontal road. They have an acceleration of  $2.0 \text{ m s}^{-2}$ .

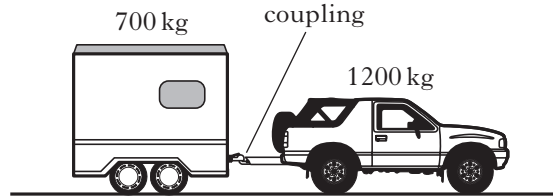

Assuming that the frictional forces are negligible, the tension in the coupling between the car and the horsebox is

- A 500 N
- B 700 N
- C 1400 N
- D 2400 N
- E 3800 N.

4. Two trolleys travel towards each other in a straight line along a frictionless surface.

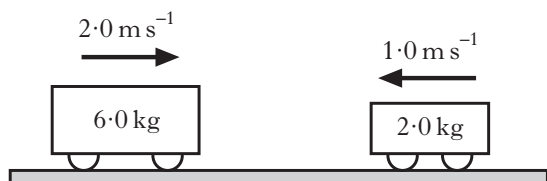

The trolleys collide. After the collision the trolleys move as shown below.

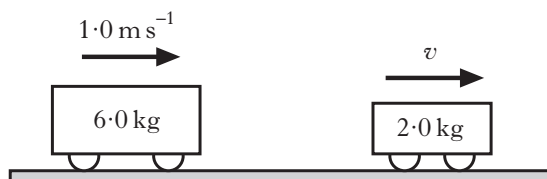

Which row in the table gives the total momentum and the total kinetic energy **after** the collision?

|   | Total momentum/<br>$\text{kg m s}^{-1}$ | Total kinetic energy/<br>J |
|---|---|----------------------------|
| A | 10                                      | 7.0                        |
| B | 10                                      | 13                         |
| C | 10                                      | 20                         |
| D | 14                                      | 13                         |
| E | 14                                      | 7.0                        |

5. An aircraft cruises at an altitude at which the external air pressure is  $0.40 \times 10^5 \text{ Pa}$ . The air pressure inside the aircraft cabin is maintained at  $1.0 \times 10^5 \text{ Pa}$ . The area of an external cabin door is  $2.0 \text{ m}^2$ .

What is the outward force on the door due to the pressure difference?

- A  $0.30 \times 10^5 \text{ N}$   
 B  $0.70 \times 10^5 \text{ N}$   
 C  $1.2 \times 10^5 \text{ N}$   
 D  $2.0 \times 10^5 \text{ N}$   
 E  $2.8 \times 10^5 \text{ N}$

6. A cylinder of height  $1.0 \text{ m}$  is held stationary in a swimming pool. The top of the cylinder is at a depth of  $1.5 \text{ m}$  below the surface of the water.

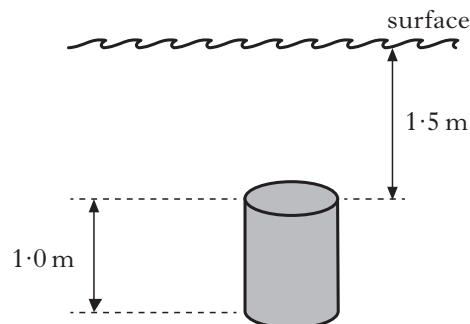

The density of the water is  $1.0 \times 10^3 \text{ kg m}^{-3}$ .

The pressure due to the water exerted on the top surface of the cylinder is

- A  $1.5 \times 10^3 \text{ N m}^{-2}$   
 B  $4.9 \times 10^3 \text{ N m}^{-2}$   
 C  $9.8 \times 10^3 \text{ N m}^{-2}$   
 D  $14.7 \times 10^3 \text{ N m}^{-2}$   
 E  $24.5 \times 10^3 \text{ N m}^{-2}$ .

7. A fixed mass of gas is heated inside a rigid container. As its temperature changes from  $T_1$  to  $T_2$  the pressure increases from  $1.0 \times 10^5 \text{ Pa}$  to  $2.0 \times 10^5 \text{ Pa}$ .

Which row in the table shows possible values for  $T_1$  and  $T_2$ ?

|   | $T_1$              | $T_2$               |
|---|--------------------|---------------------|
| A | $27^\circ\text{C}$ | $327^\circ\text{C}$ |
| B | $30^\circ\text{C}$ | $60^\circ\text{C}$  |
| C | $80^\circ\text{C}$ | $40^\circ\text{C}$  |
| D | $303 \text{ K}$    | $333 \text{ K}$     |
| E | $600 \text{ K}$    | $300 \text{ K}$     |

[Turn over

8. One volt is equivalent to one

- A farad per coulomb
- B ampere per ohm
- C joule per ampere
- D joule per ohm
- E joule per coulomb.

9. A Wheatstone bridge circuit is set up as shown.

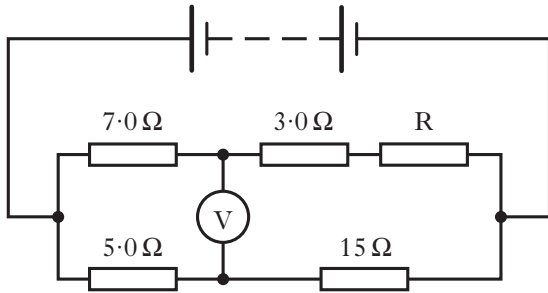

The reading on the voltmeter is zero.

The value of resistor  $R$  is

- A  $3.0\ \Omega$
- B  $4.0\ \Omega$
- C  $18\ \Omega$
- D  $21\ \Omega$
- E  $24\ \Omega$ .

10. A Wheatstone bridge circuit is set up as shown.

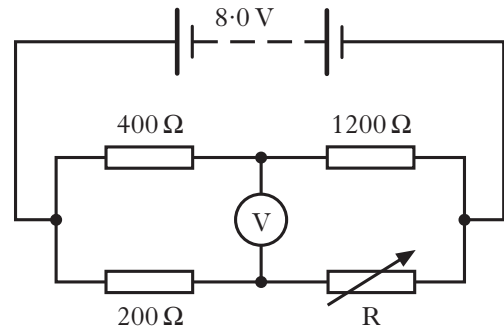

When the variable resistor  $R$  is set at  $600\ \Omega$  the bridge is balanced. When  $R$  is set at  $601\ \Omega$  the reading on the voltmeter is  $+2.5\ \text{mV}$ .

$R$  is now set at  $598\ \Omega$ .

The reading on the voltmeter is

- A  $-7.5\ \text{mV}$
- B  $-5.0\ \text{mV}$
- C  $-2.5\ \text{mV}$
- D  $+5.0\ \text{mV}$
- E  $+7.5\ \text{mV}$ .

11. The output of a  $50\ \text{Hz}$  a.c. supply is connected to the input of an oscilloscope. The trace produced on the screen of the oscilloscope is shown.

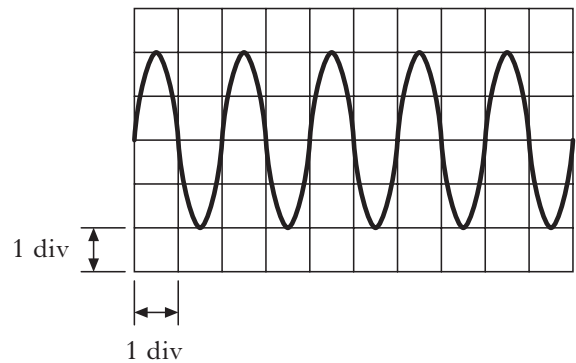

The time-base control of the oscilloscope is set at

- A  $1\ \text{ms/div}$
- B  $10\ \text{ms/div}$
- C  $20\ \text{ms/div}$
- D  $100\ \text{ms/div}$
- E  $200\ \text{ms/div}$ .

12. An a.c. supply with an output voltage of 6.0 V r.m.s. is connected to a 3.0 Ω resistor.

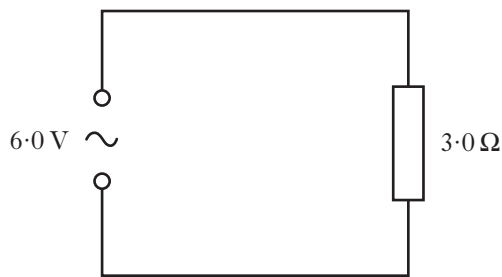

Which row in the table shows the peak voltage across the resistor and the peak current in the circuit?

|   | Peak voltage/V       | Peak current/A       |
|---|----------------------|----------------------|
| A | $6\sqrt{2}$          | $2\sqrt{2}$          |
| B | $6\sqrt{2}$          | 2                    |
| C | 6                    | 2                    |
| D | $\frac{6}{\sqrt{2}}$ | $\frac{2}{\sqrt{2}}$ |
| E | 6                    | $2\sqrt{2}$          |

13. In an experiment to find the capacitance of a capacitor, a student makes the following measurements.

potential difference across capacitor =  $(10.0 \pm 0.1)$  V

charge stored by capacitor =  $(500 \pm 25)$  μC

Which row in the table gives the capacitance of the capacitor and the percentage uncertainty in the capacitance?

|   | Capacitance/μF | Percentage uncertainty |
|---|----------------|------------------------|
| A | 0.02           | 1                      |
| B | 0.02           | 5                      |
| C | 50             | 1                      |
| D | 50             | 5                      |
| E | 5000           | 6                      |

14. A capacitor is connected to an a.c. supply and a.c. ammeter as shown.

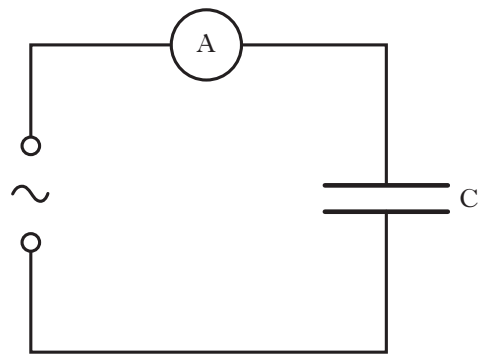

The supply has a constant peak voltage, but its frequency can be varied.

Which graph shows how the current  $I$  varies with the frequency  $f$  of the supply?

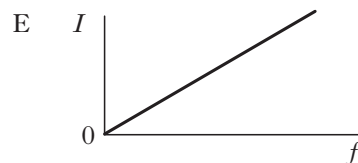
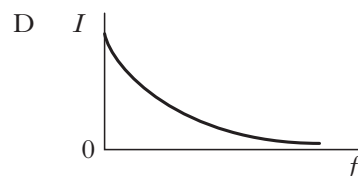
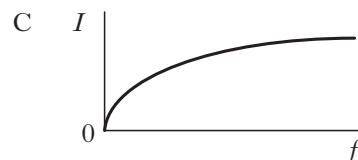
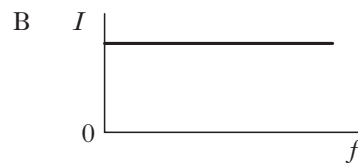
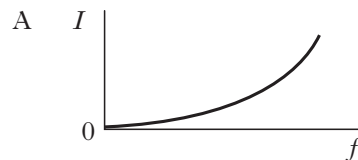

[Turn over

15. Two identical loudspeakers,  $L_1$  and  $L_2$ , are connected to a signal generator as shown.

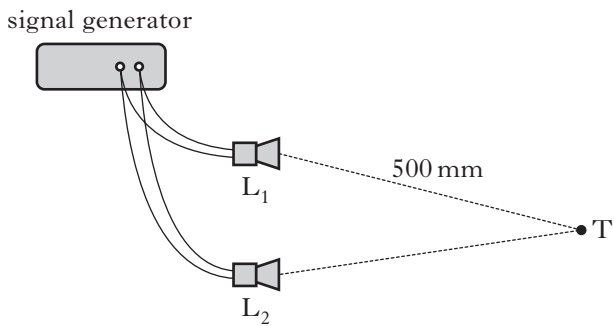

An interference pattern is produced.

A minimum is detected at point  $T$ .

The wavelength of the sound is 40 mm.

The distance from  $L_1$  to  $T$  is 500 mm.

The distance from  $L_2$  to  $T$  is

- A 450 mm
  - B 460 mm
  - C 470 mm
  - D 480 mm
  - E 490 mm.
16. The irradiance of light from a point source is  $20 \text{ W m}^{-2}$  at a distance of 5.0 m from the source.
- What is the irradiance of the light at a distance of 25 m from the source?
- A  $0.032 \text{ W m}^{-2}$
  - B  $0.80 \text{ W m}^{-2}$
  - C  $4.0 \text{ W m}^{-2}$
  - D  $100 \text{ W m}^{-2}$
  - E  $500 \text{ W m}^{-2}$

17. The diagram below represents part of the process of stimulated emission in a laser.

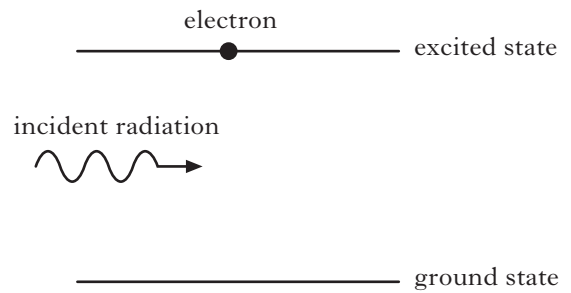

Which statement best describes the emitted radiation?

- A Out of phase and emitted in the same direction as the incident radiation.
  - B Out of phase and emitted in the opposite direction to the incident radiation.
  - C Out of phase and emitted in all directions.
  - D In phase and emitted in the same direction as the incident radiation.
  - E In phase and emitted in the opposite direction to the incident radiation.
18. In an n-type semiconductor
- A the majority charge carriers are electrons
  - B the majority charge carriers are holes
  - C the majority charge carriers are protons
  - D there are more protons than electrons
  - E there are more electrons than protons.



19. The following statement represents a nuclear decay.

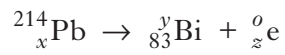

Which row in the table shows the correct values of  $x$ ,  $y$  and  $z$  for this decay?

|   | $x$ | $y$ | $z$ |
|---|-----|-----|-----|
| A | 82  | 210 | -1  |
| B | 82  | 214 | -1  |
| C | 84  | 214 | 1   |
| D | 85  | 210 | 2   |
| E | 85  | 214 | 2   |

20. The graph shows how the corrected count rate from a radioactive source varies with the thickness of a material placed between the source and a detector.

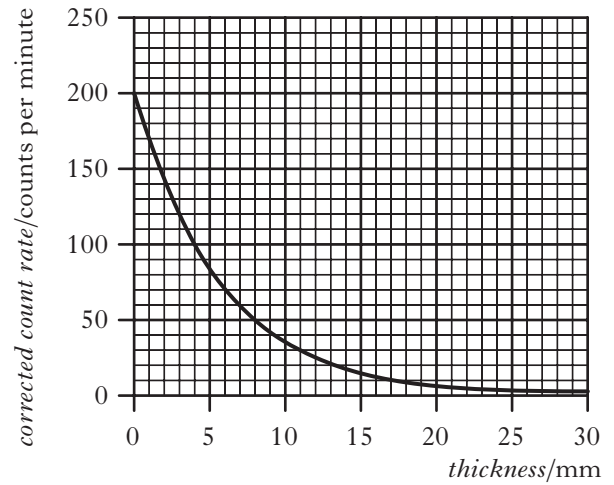

The half value thickness of the material is

- A 4 mm
- B 14 mm
- C 28 mm
- D 100 mm
- E 200 mm.

**[Turn over**

SECTION B

Marks

Write your answers to questions 21 to 30 in the answer book.

21. A student investigates the motion of a ball projected from a launcher. The launcher is placed on the ground and a ball is fired vertically upwards. The vertical speed of the ball as it leaves the top of the launcher is  $7.0 \text{ m s}^{-1}$ . The effects of air resistance can be ignored.

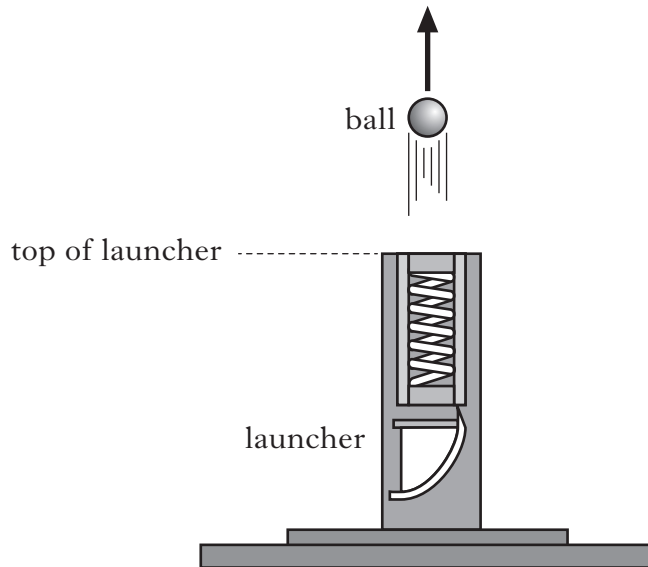

- (a) (i) Calculate the maximum height above the top of the launcher reached by the ball. 2
- (ii) Show that the time taken for the ball to reach its maximum height is  $0.71 \text{ s}$ . 1

## 21. (continued)

- (b) The student now fixes the launcher to a trolley. The trolley travels horizontally at a constant speed of  $1.5 \text{ m s}^{-1}$  to the right.

The launcher again fires the ball vertically upwards with a speed of  $7.0 \text{ m s}^{-1}$ .

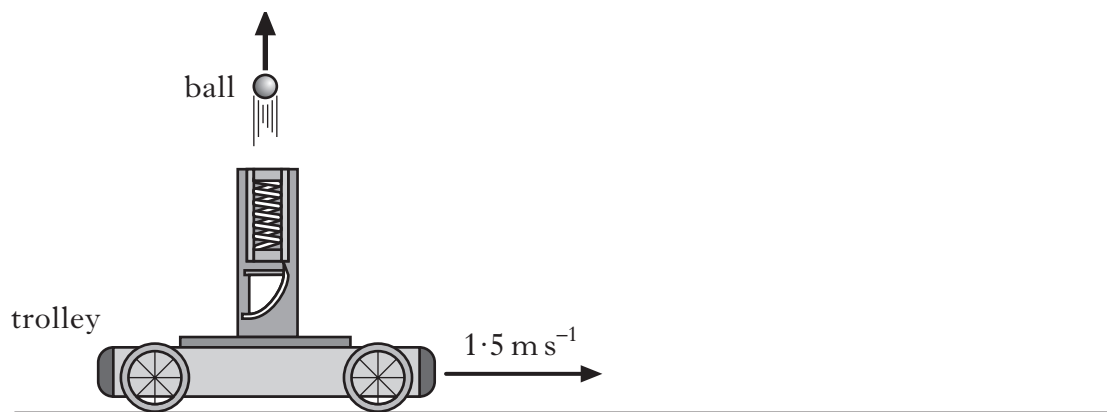

- (i) Determine the velocity of the ball after  $0.71 \text{ s}$ . 1
- (ii) The student asks some friends to predict where the ball will land relative to the moving launcher. They make the following statements.

*Statement X: The ball will land behind the launcher.*

*Statement Y: The ball will land in front of the launcher.*

*Statement Z: The ball will land on top of the launcher.*

Which of the statements is correct?

You must justify your answer. 2

(6)

[Turn over

22. An experiment is set up to investigate the motion of a cart as it collides with a force sensor.

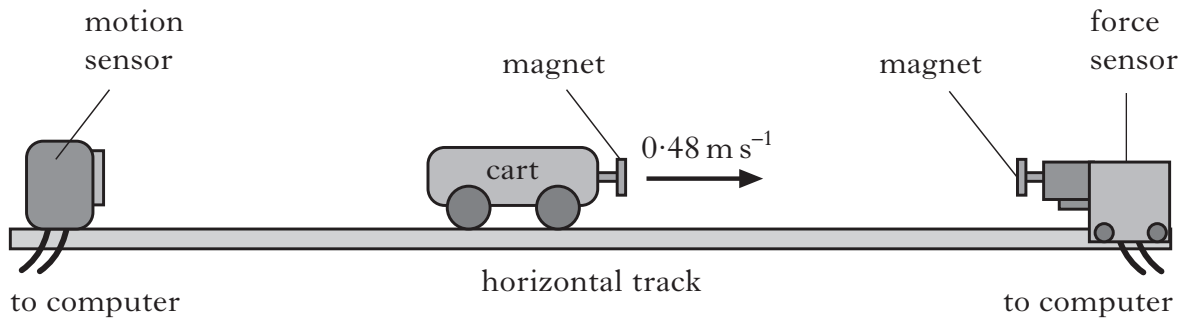

The cart moves along the horizontal track at  $0.48 \text{ m s}^{-1}$  to the right.

As the cart approaches the force sensor, the magnets repel each other and exert a force on the cart.

The computer attached to the force sensor displays the following force-time graph for this collision.

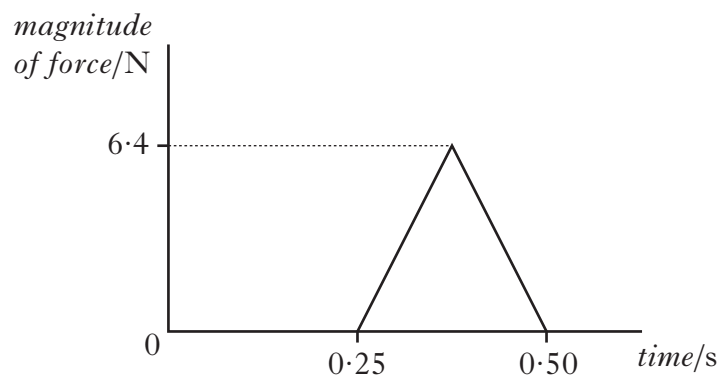

The computer attached to the motion sensor displays the following velocity-time graph for the cart.

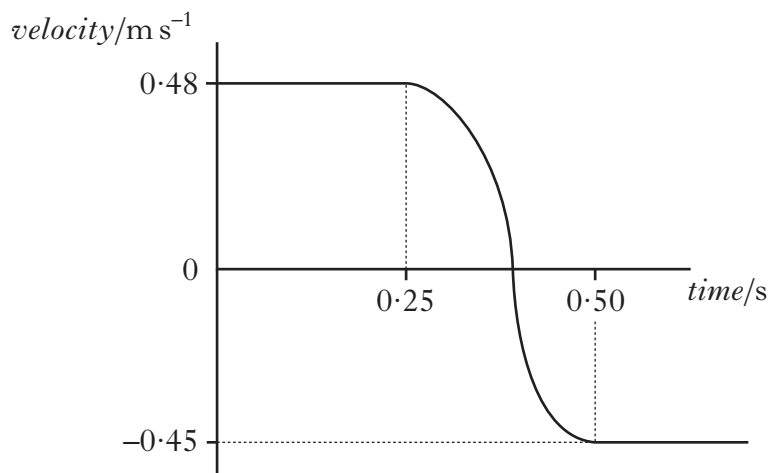

**22. (continued)**

- (a) (i) Calculate the magnitude of the impulse on the cart during the collision. **2**
- (ii) Determine the magnitude and direction of the change in momentum of the cart. **1**
- (iii) Calculate the mass of the cart. **2**

- (b) The experiment is repeated using different magnets which produce a greater average force on the cart during the collision. As before, the cart is initially travelling at  $0.48 \text{ m s}^{-1}$  to the right and the collision causes the same change in its velocity.

Copy the force-time graph shown and, on the same axes, draw another graph to show how the magnitude of the force varies with time in this collision.

Numerical values are not required but you must label each graph clearly. **2**

**(7)****[Turn over**

23. A technician uses the equipment shown to calculate a value for the density of air at room temperature.

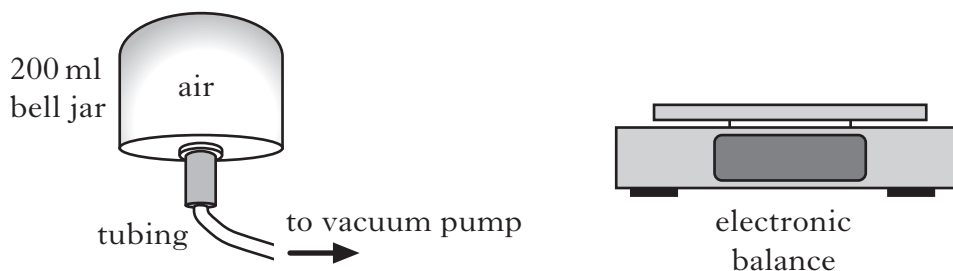

The mass of the bell jar is measured when it is full of air. The vacuum pump is then used to remove air from the bell jar. The mass of the bell jar is measured again.

The following measurements are obtained.

$$\text{Mass before air is removed} = 111.49 \text{ g}$$

$$\text{Mass after air is removed} = 111.26 \text{ g}$$

$$\text{Volume of bell jar} = 200 \text{ ml} = 2.0 \times 10^{-4} \text{ m}^3$$

- (a) (i) Use these measurements to calculate a value for the density of air in  $\text{kg m}^{-3}$ . 2
- (ii) The accepted value for the density of air at this temperature is  $1.29 \text{ kg m}^{-3}$ . Explain why the technician's answer is different from the accepted value. 1
- (b) Air is allowed back into the bell jar until it reaches a pressure of  $1.01 \times 10^5 \text{ Pa}$ . The technician now uses a syringe to remove 50 ml of the air from the bell jar.

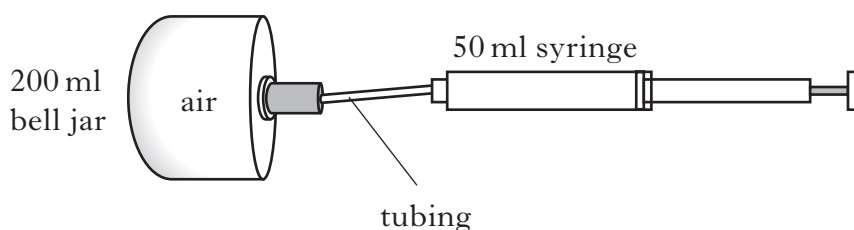

The temperature of the air remains constant.

- (i) Calculate the new pressure of the air inside the bell jar. 2
- (ii) Use the kinetic model to explain this change in pressure after removing air with the syringe. 2

(7)

24. (a) A supply of e.m.f.  $10.0\text{ V}$  and internal resistance  $r$  is connected in a circuit as shown in Figure 1.

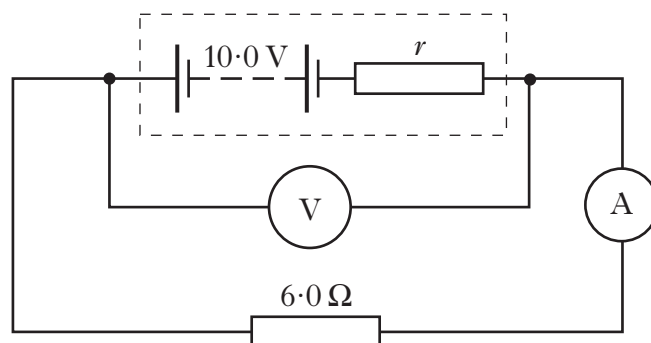

Figure 1

The meters display the following readings.

Reading on ammeter =  $1.25\text{ A}$

Reading on voltmeter =  $7.50\text{ V}$

- (i) What is meant by an *e.m.f. of  $10.0\text{ V}$* ? 1
- (ii) Show that the internal resistance,  $r$ , of the supply is  $2.0\ \Omega$ . 1
- (b) A resistor R is connected to the circuit as shown in Figure 2.

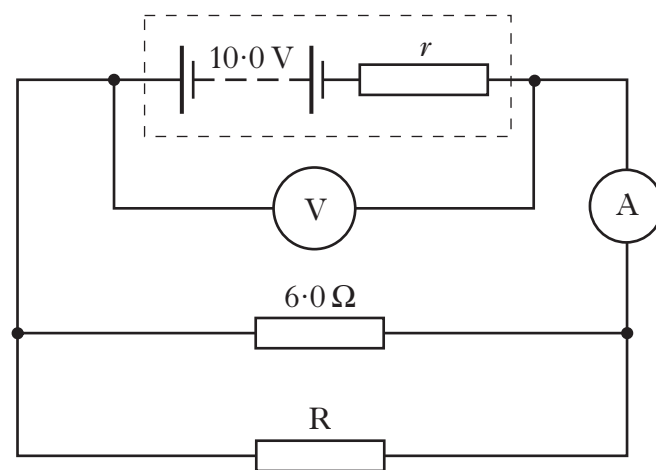

Figure 2

The meters now display the following readings.

Reading on ammeter =  $2.0\text{ A}$

Reading on voltmeter =  $6.0\text{ V}$

- (i) Explain why the reading on the voltmeter has decreased. 2
- (ii) Calculate the resistance of resistor R. 3
- (7)**

25. A student carries out an experiment using a circuit which includes a capacitor with a capacitance of  $200\ \mu\text{F}$ .

(a) Explain what is meant by a *capacitance of  $200\ \mu\text{F}$* .

1

(b) The capacitor is used in the circuit shown to measure the time taken for a ball to fall vertically between two strips of metal foil.

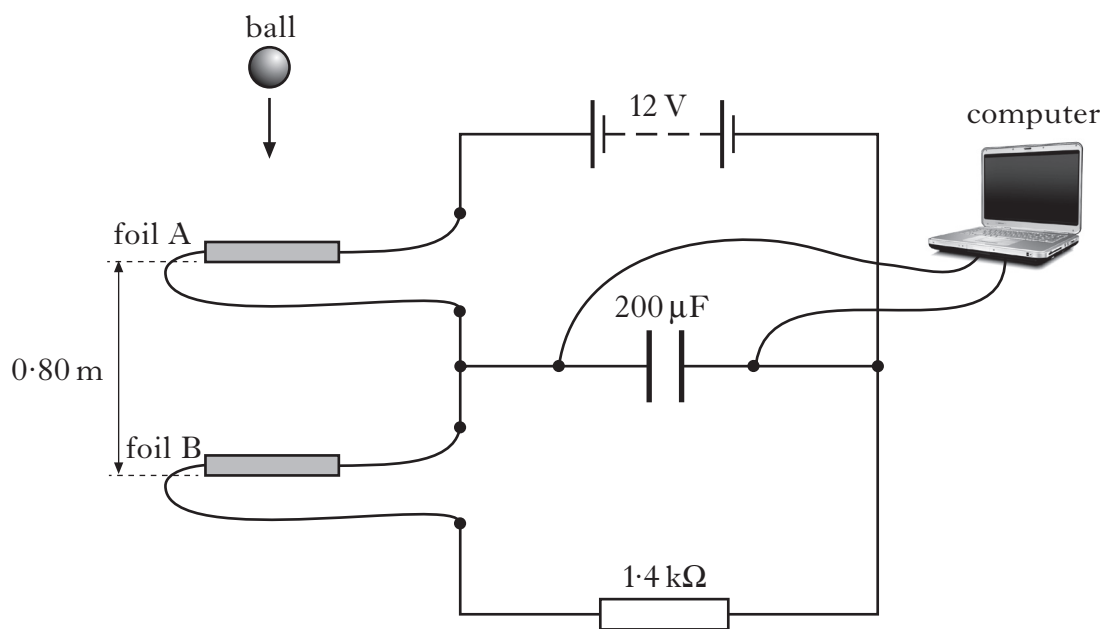

The ball is dropped from rest above foil A. It is travelling at  $1.5\ \text{ms}^{-1}$  when it reaches foil A. It breaks foil A, then a short time later breaks foil B. These strips of foil are  $0.80\ \text{m}$  apart.

The computer displays a graph of potential difference across the capacitor against time as shown.

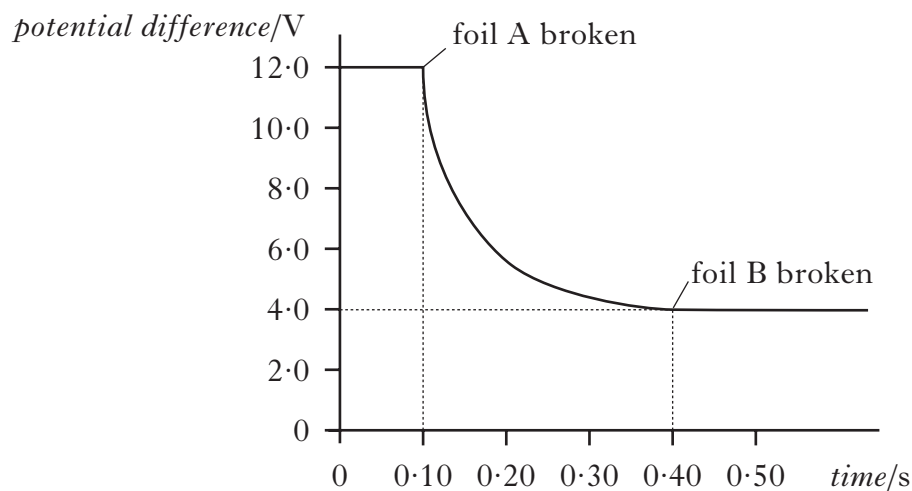

(i) Calculate the current in the  $1.4\ \text{k}\Omega$  resistor at the moment foil A is broken.

2

(ii) Calculate the **decrease** in the energy stored in the capacitor during the time taken for the ball to fall from foil A to foil B.

3



25. (continued)

- (c) The measurements from this experiment are now used to estimate the acceleration due to gravity.
- (i) What is the time taken for the ball to fall from foil A to foil B? 1
  - (ii) Use the results of this experiment to calculate a value for the acceleration due to gravity. 2
  - (iii) The distance between the two foils is now increased and the experiment repeated. Explain why this gives a more accurate result for the acceleration due to gravity. 1
- (10)**

**[Turn over**

26. (a) An op-amp is connected in a circuit as shown.

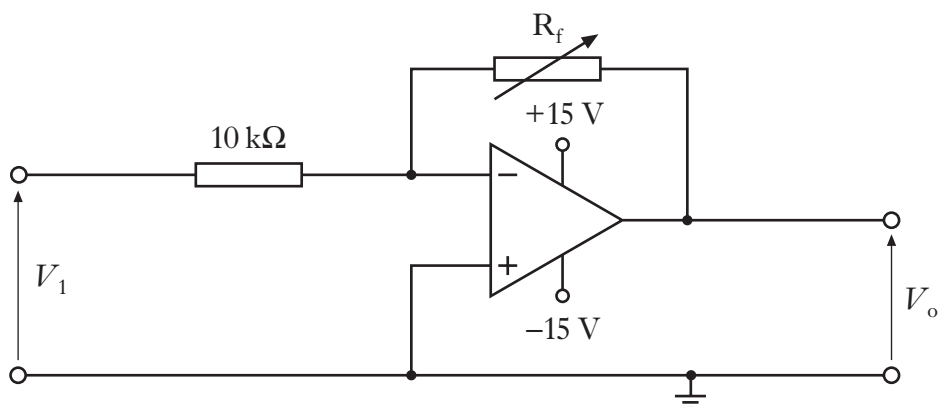

The resistance of the feedback resistor  $R_f$  is varied between  $20\text{ k}\Omega$  and  $120\text{ k}\Omega$ .

The graph shows how the output voltage  $V_o$  varies as the resistance of the feedback resistor is increased.

output voltage  $V_o/\text{V}$

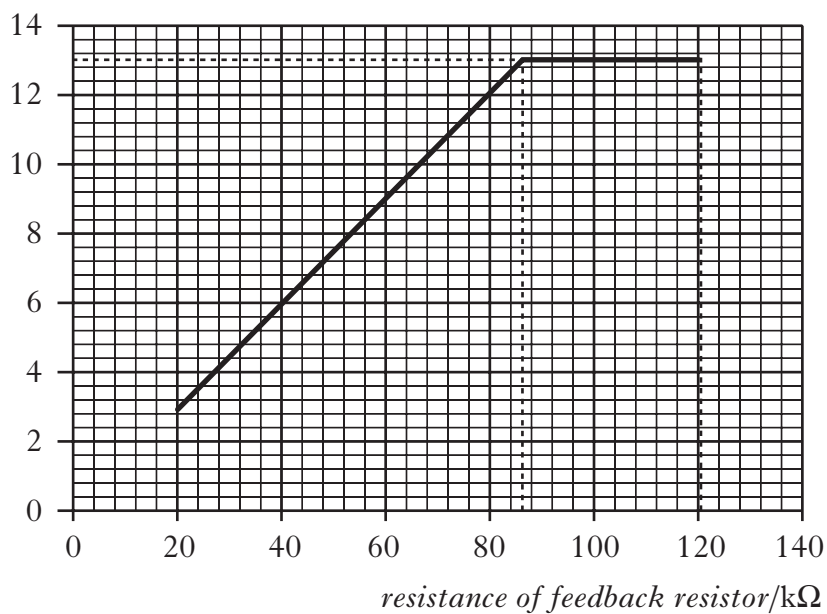

- (i) In which mode is the op-amp being used? 1
- (ii) Calculate the input voltage  $V_1$ . 2
- (iii) Explain why the output voltage  $V_o$  does not increase above 13 V. 1

26. (continued)

(b) The op-amp is now connected in a different circuit as shown.

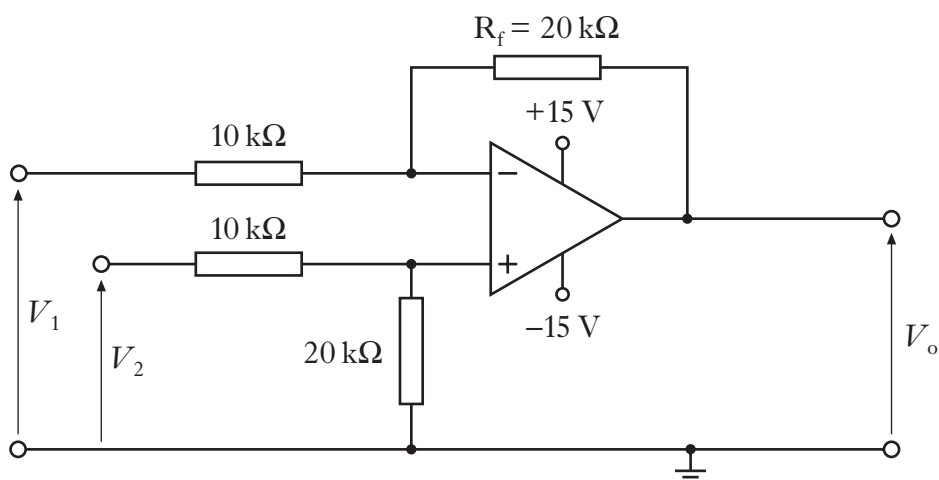

The input voltages  $V_1$  and  $V_2$  are now varied and the corresponding output voltage  $V_o$  is measured.

Graph 1 shows the input voltage  $V_1$  for the first 3 seconds.

Graph 2 shows the input voltage  $V_2$  for the first 3 seconds.

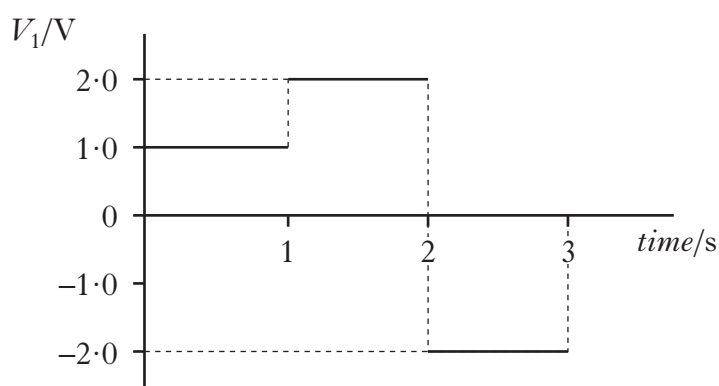

Graph 1

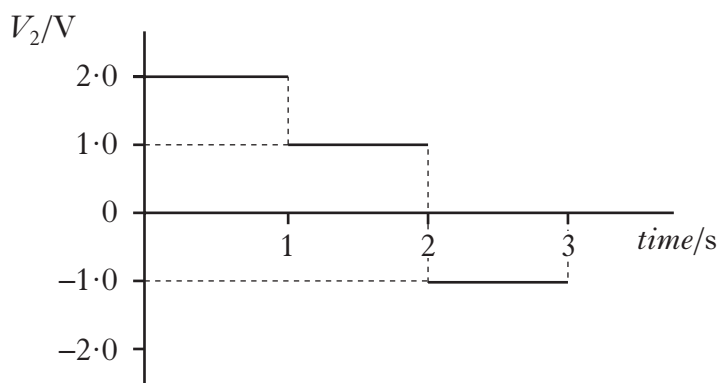

Graph 2

Sketch a graph to show the output voltage  $V_o$  from the op-amp for the first 3 seconds.

Numerical values are required on both the voltage and time axes.

3  
(7)

27. (a) A ray of red light is incident on a block of glass as shown.

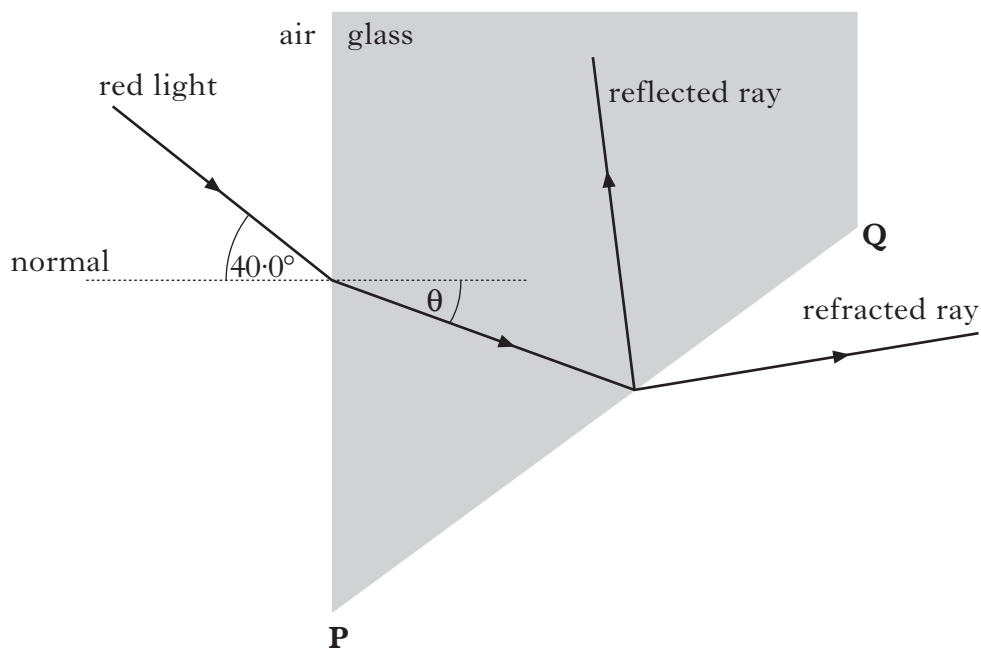

The refractive index of the glass for this light is 1.66.

- (i) Calculate the value of the angle  $\theta$  shown in the diagram. 2
- (ii) The direction of the incident light ray is now changed so that the refracted ray emerges along face **PQ** as shown.

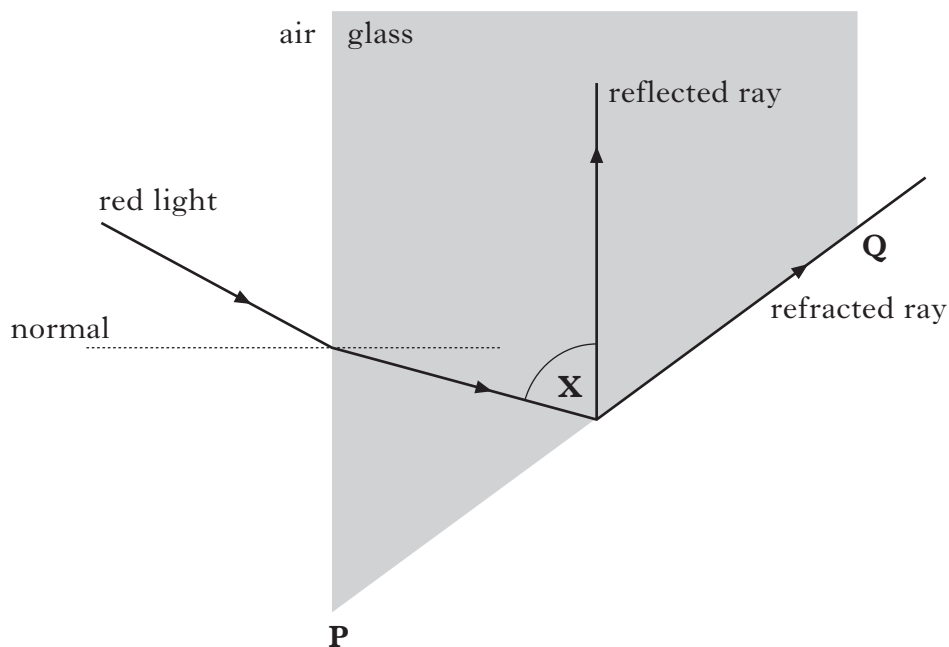

- (A) Calculate the critical angle for the red light in this glass. 2
- (B) Determine the size of angle **X** shown in the diagram. 1

27. (continued)

(b) The ray of red light is now replaced with a ray of blue light.

This ray of blue light is directed towards the block along the same path as the ray of red light in part (a)(ii).

Is this ray of blue light refracted at face **PQ**?

Justify your answer.

2

(7)

[Turn over

28. (a) The first demonstration of the interference of light was performed by Thomas Young in 1801.

What does the demonstration of interference prove about light?

1

- (b) A grating is placed in a colourless liquid in a container. Laser light is incident on the grating along the normal. The spacing between the lines on the grating is  $5.0 \times 10^{-6}$  m. Interference occurs and the maxima produced are shown in the diagram.

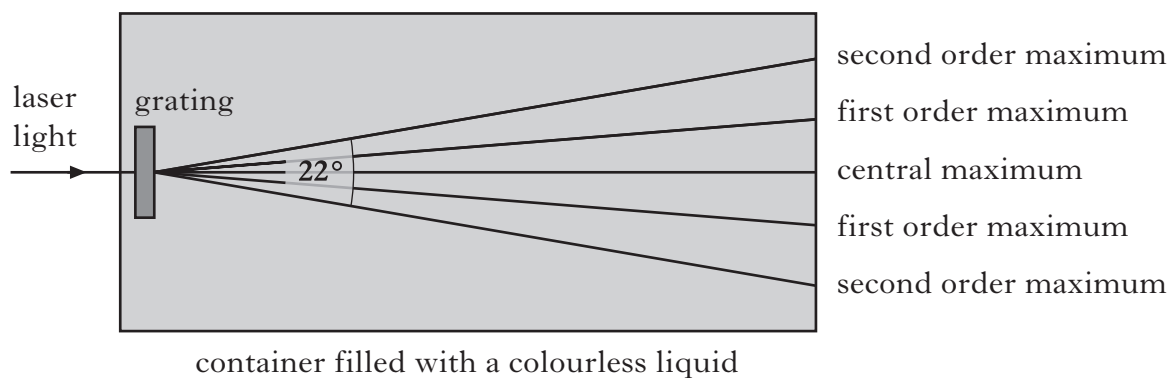

- (i) Calculate the wavelength of the laser light in the liquid.
- (ii) The refractive index of the colourless liquid decreases as the temperature of the liquid increases.

2

The liquid is now heated.

What effect does this have on the spacing between the maxima?

You must justify your answer.

2

(5)

29. A metal plate emits electrons when certain wavelengths of electromagnetic radiation are incident on it.

Marks

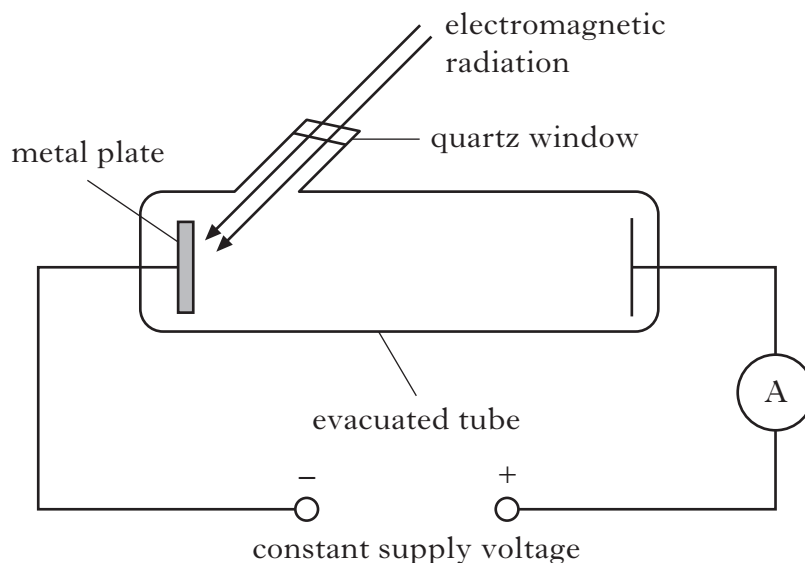

The work function of the metal is  $2.24 \times 10^{-19}$  J.

- (a) Electrons are released when electromagnetic radiation of wavelength 525 nm is incident on the surface of the metal plate.

(i) Show that the energy of each photon of the incident radiation is  $3.79 \times 10^{-19}$  J.

2

(ii) Calculate the maximum kinetic energy of an electron released from the surface of the metal plate.

1

- (b) The frequency of the incident radiation is now varied through a range of values. The maximum kinetic energy of electrons leaving the metal plate is determined for each frequency.

A graph of this maximum kinetic energy against frequency is shown.

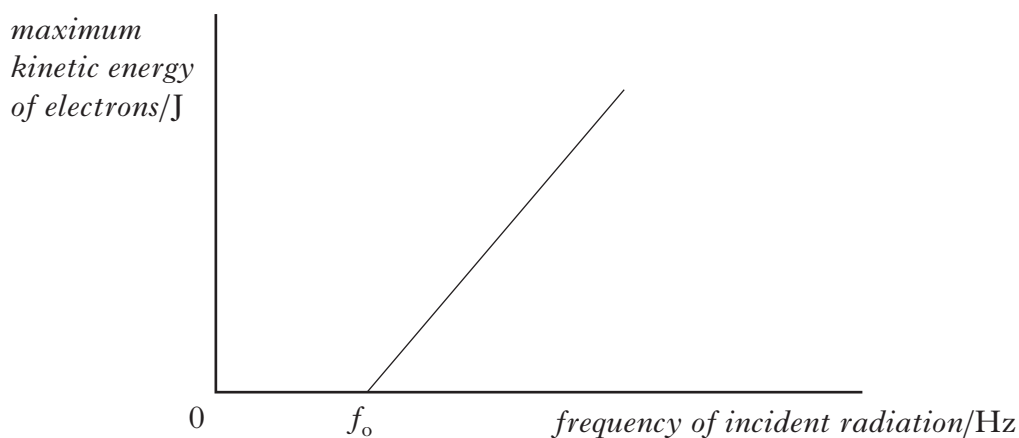

(i) Explain why the kinetic energy of the electrons is zero below the frequency  $f_0$ .

1

(ii) Calculate the value of the frequency  $f_0$ .

2

(6)

[Turn over for Question 30 on Page twenty-four

30. (a) The Sun is the source of most of the energy on Earth. This energy is produced by nuclear reactions which take place in the interior of the Sun.

One such reaction can be described by the following statement.

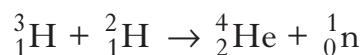

The masses of the particles involved in this reaction are shown in the table.

| <i>Particle</i>   | <i>Mass/kg</i>          |
|-------------------|-------------------------|
| ${}^3_1\text{H}$  | $5.005 \times 10^{-27}$ |
| ${}^2_1\text{H}$  | $3.342 \times 10^{-27}$ |
| ${}^4_2\text{He}$ | $6.642 \times 10^{-27}$ |
| ${}^1_0\text{n}$  | $1.675 \times 10^{-27}$ |

- (i) Name this type of nuclear reaction. 1
- (ii) Calculate the energy released in this reaction. 3
- (b) The Sun emits a continuous spectrum of visible light. When this light passes through hydrogen atoms in the Sun's outer atmosphere, certain wavelengths are absorbed.

The diagram shows some of the energy levels for the hydrogen atom.

|       |  |                                     |
|-------|--|-------------------------------------|
| $E_3$ |  | $-1.360 \times 10^{-19} \text{ J}$  |
| $E_2$ |  | $-2.416 \times 10^{-19} \text{ J}$  |
| $E_1$ |  | $-5.424 \times 10^{-19} \text{ J}$  |
| $E_0$ |  | $-21.760 \times 10^{-19} \text{ J}$ |

- (i) One of the wavelengths absorbed by the hydrogen atoms results in an electron transition from energy level  $E_1$  to  $E_3$ .  
Calculate this wavelength. 3
- (ii) The absorption of this wavelength produces a faint dark line in the continuous spectrum from the Sun.  
In which colour of the spectrum is this dark line observed? 1
- (8)**

[END OF QUESTION PAPER]