



FOR OFFICIAL USE

--	--	--	--	--	--

National
Qualifications
2018

Mark

--

X862/75/01

Practical Woodworking

MONDAY, 28 MAY

2:30 PM – 3:30 PM



* X 8 6 2 7 5 0 1 *

Fill in these boxes and read what is printed below.

Full name of centre

--

Town

--

Forename(s)

--

Surname

--

Number of seat

--

Date of birth

Day

--	--

Month

--	--

Year

--	--

Scottish candidate number

--	--	--	--	--	--	--	--	--	--

Total marks — 60

Attempt ALL questions.

Write your answers clearly in the spaces provided in this booklet. Additional space for answers is provided at the end of this booklet. If you use this space you must clearly identify the question number you are attempting.

Use **blue** or **black** ink.

Before leaving the examination room you must give this booklet to the Invigilator; if you do not, you may lose all the marks for this paper.



* X 8 6 2 7 5 0 1 0 1 *

Total marks — 60
Attempt ALL questions

1. A mirror is shown below.

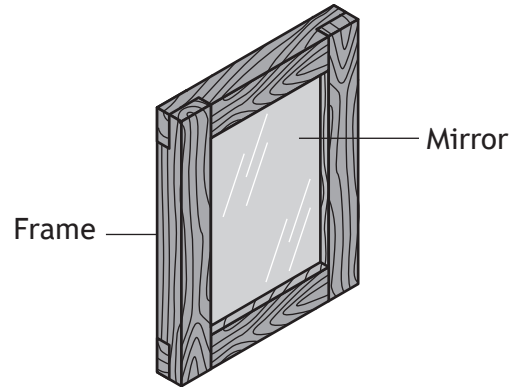

The mirror frame is made using corner halving joints.

As part of the design process various other joints were considered, three of which are shown.

(a) Name the joints shown.

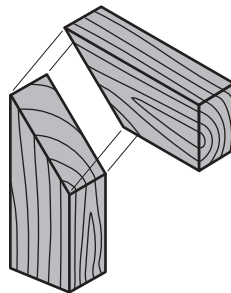

(i) _____

1

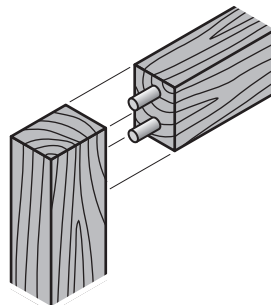

(ii) _____

1



1. (a) (continued)

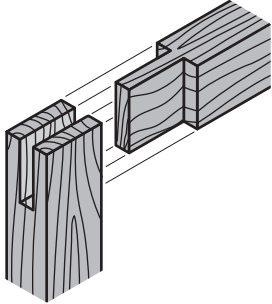

(iii) _____

1

[Turn over



1. (continued)

The corner halving joint used in the mirror frame is shown below.

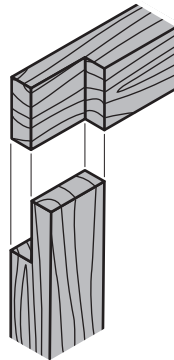

An important part of making any joint is marking out.

There are four stages in the marking out process.

- (b) Describe three stages in the **marking out** process in the table below. You may use sketches to support your answer.

The stages must be in the correct order.

The final stage is completed for you.

3

Sequence	Process
Stage 1	
Stage 2	
Stage 3	
Stage 4	Mark the waste wood.

1. (continued)

The mirror frame is recessed to allow the mirror to be fitted, as shown below.

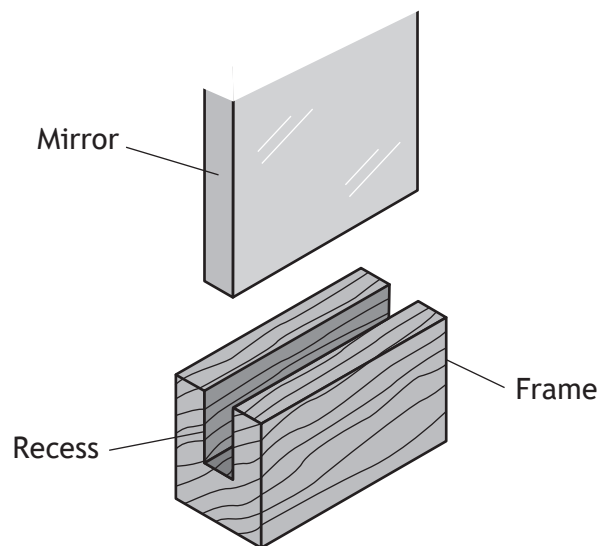

The tool shown below is used to cut the recess.

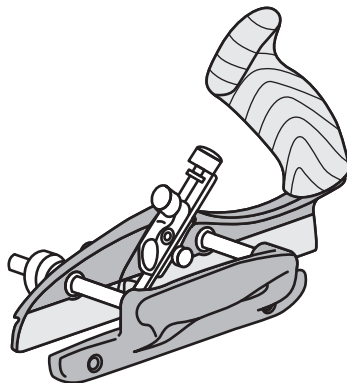

(c) Name this tool.

1

[Turn over



1. (continued)

Various types of woods were considered to make the mirror frame.

- (d) Complete the table below identifying if the woods listed are hardwood or softwood.

The first one is completed for you.

4

Wood	Hardwood/Softwood
Meranti	Hardwood
Oak	(i)
Ash	(ii)
Cedar	(iii)
Larch	(iv)

It was decided to use softwood to make the mirror frame.

- (e) Describe two environmental reasons for selecting a softwood **instead** of a hardwood.

2

1 _____

2 _____

The mirror frame requires a finish to be applied which will protect the wood and show off the natural wood grain.

- (f) State a suitable finish.

1



[Turn over for next question

DO NOT WRITE ON THIS PAGE



* X 8 6 2 7 5 0 1 0 7 *

2. A table is shown below.

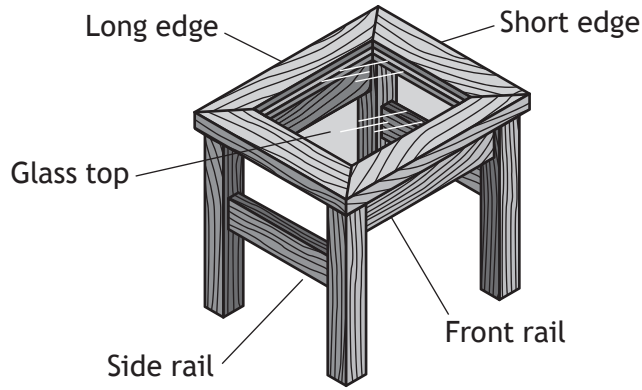

The diagram below shows the working drawings for the table.

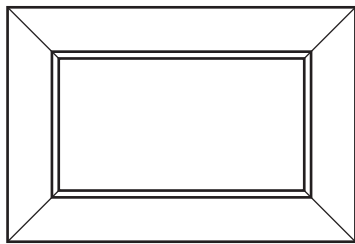

Plan

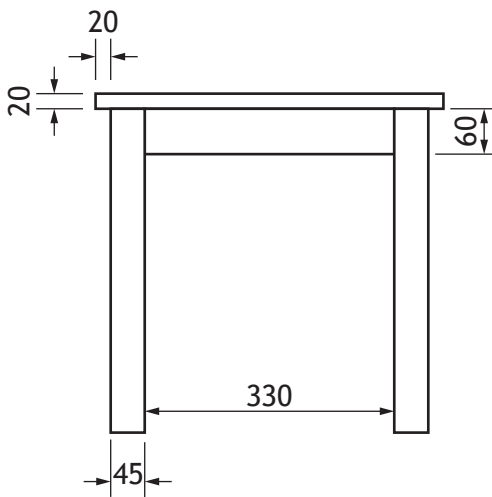

Elevation

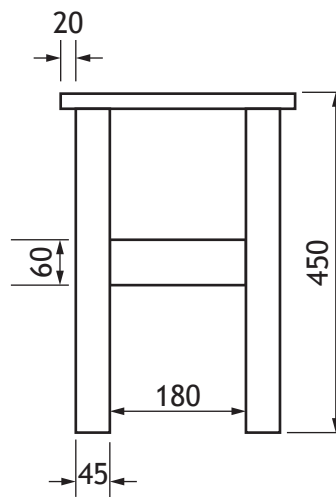

End Elevation

Front rail

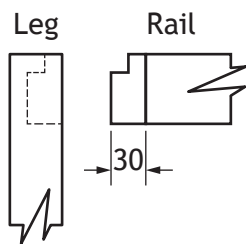

Side rail

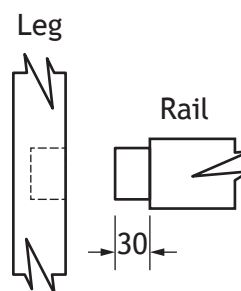

Note: The rails are joined to the legs using the joints shown in the drawings above. All sizes are in millimetres.

DO NOT
WRITE IN
THIS
MARGIN



* X 8 6 2 7 5 0 1 0 8 *

2. (continued)

- (a) Complete the cutting list below, using the information provided in the working drawings shown opposite.

6

Part	Number	Length	Breadth	Thickness
Table top long edge	2		50	20
Table top short edge	2		50	20
Front Rails	2		60	18
Side Rails	2			18
Legs	4		45	45

Various machines are used to make the table.

- (b) Name the machines shown below.

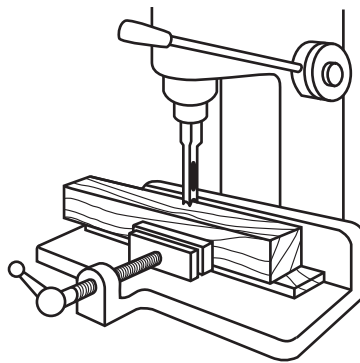

(i) _____ 1

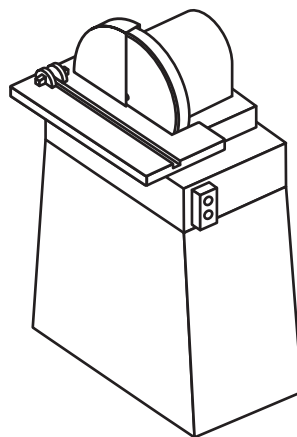

(ii) _____ 1



2. (continued)

The table top has glass inserted, as shown below.

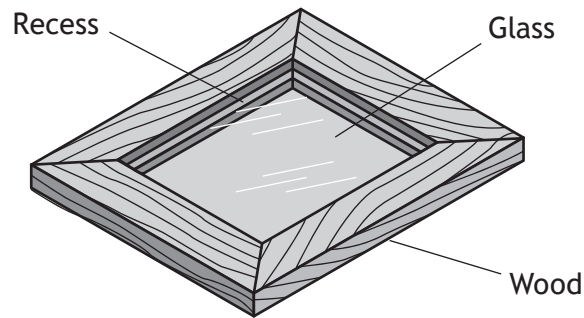

Exploded view

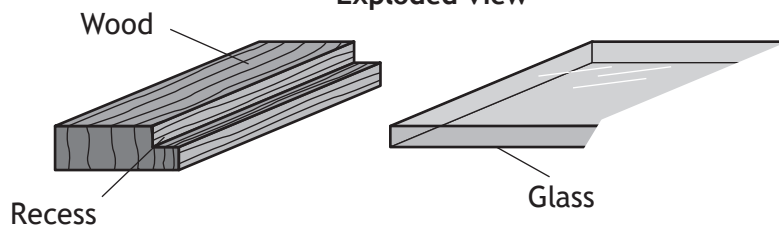

Assembled view

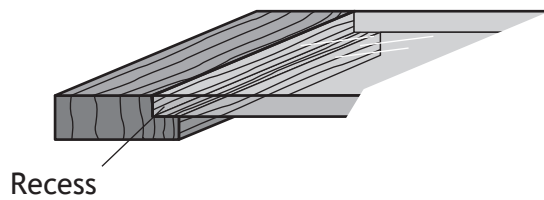

The hand tool shown below is used to cut the recess.

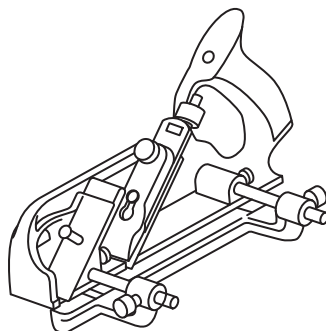

(c) Name this tool.

1



2. (continued)

The tool shown below is used during the assembly of the table top.

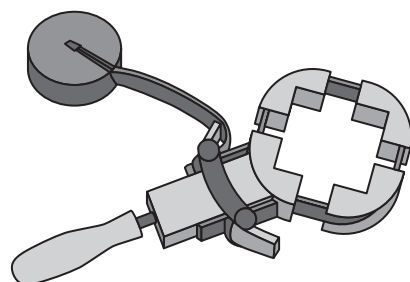

(d) Name this tool.

1

Before final assembly, the table top is dry cramped.

(e) Explain the purpose of dry cramping.

1

Glue is used to assemble the table.

(f) State the name of a wood glue.

1

Before a finish is applied to the table it is prepared using different grades of glass paper: fine, medium and coarse.

(g) State which grade of glass paper is used **first**.

1

(h) Explain the purpose of wetting the wood before starting the **final** stage of sanding.

1

[Turn over



3. A wooden tealight holder is shown below.

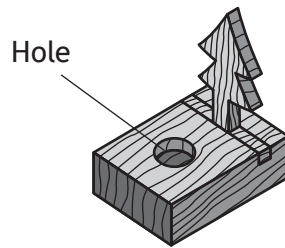

The diagrams below show the machine and forstner bit used to cut the hole in the tealight holder.

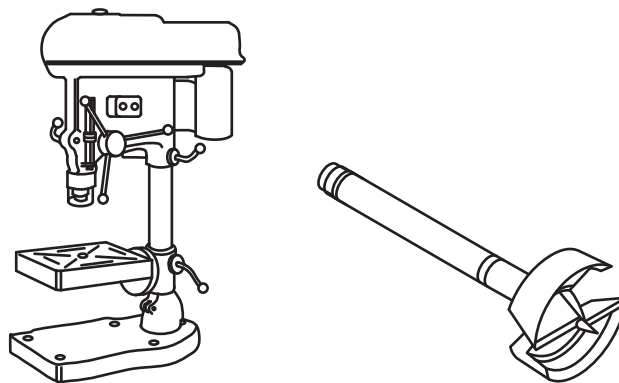

(a) (i) Name this machine. 1

(ii) Explain why the forstner bit, shown above, was used to create the hole. 1

3. (continued)

Health and safety is a priority when using the machine shown opposite.

- (b) Describe three health and safety checks that would be carried out **on the machine** before switching it on.

3

1 _____

2 _____

3 _____

[Turn over



* X 8 6 2 7 5 0 1 1 3 *

3. (continued)

The tealight holder is joined, as shown below.

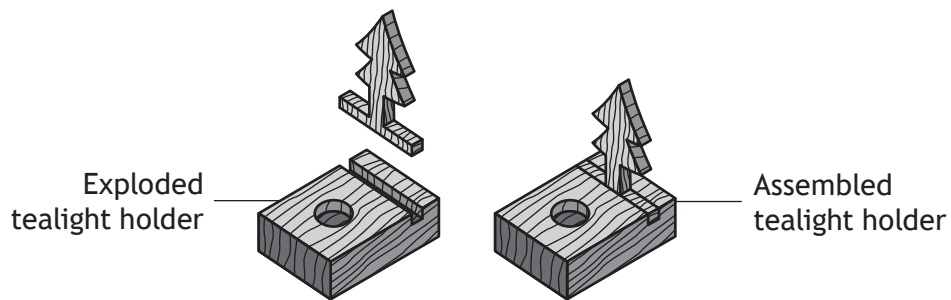

(c) Name this joint.

1



3. (continued)

Diagram A shows the marked out joint used in the tealight holder. Diagram B shows the wood that is removed.

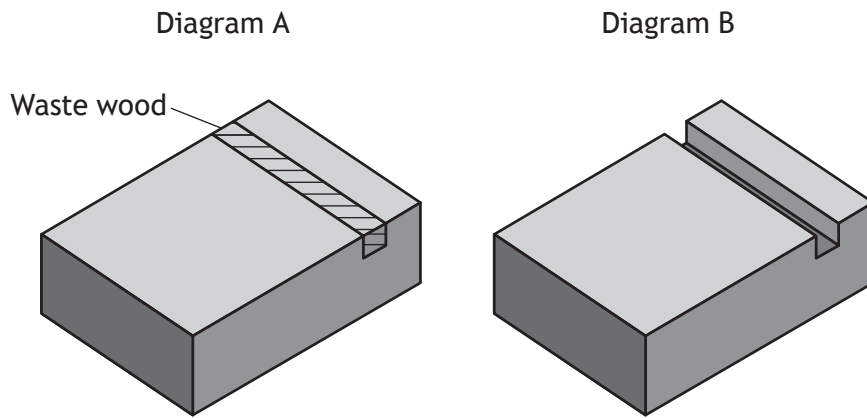

- (d) Describe three stages in **cutting and removing** the wood from the joint shown above. You may use sketches to support your answer.

3

<p>Stage 1</p>
<p>Stage 2</p>
<p>Stage 3</p>

3. (continued)

The tealight holder, shown below, is manufactured using various hand tools.

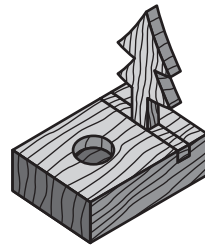

(e) Name the tools shown below and describe what they are used for.

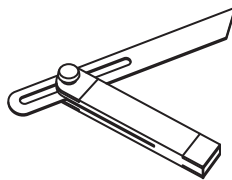

(i) Name

1

(ii) Use

1

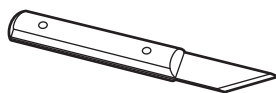

(iii) Name

1

(iv) Use

1



3. (continued)

- (f) Explain the purpose of the brass back on the tenon saw shown below.

1

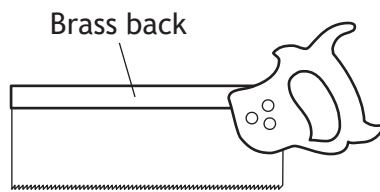

[Turn over



* X 8 6 2 7 5 0 1 1 7 *

4. A wooden bowl is shown below.

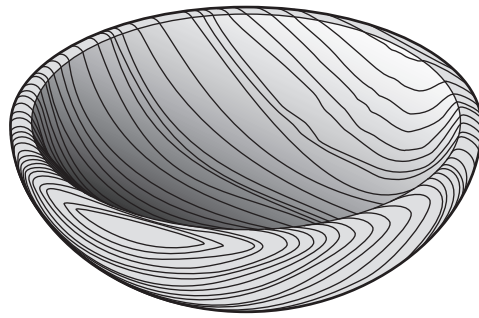

The bowl is made from one piece of material called a blank, shown below.

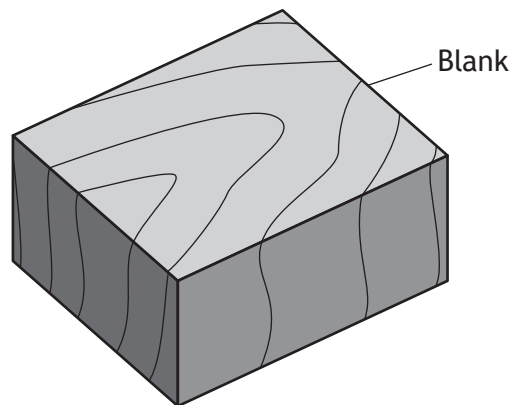

The blank has to be prepared for the turning process before it is mounted on the woodturning lathe.



* X 8 6 2 7 5 0 1 1 8 *

4. (continued)

- (a) Describe two stages in the process of **marking out** the blank.

You may use sketches to support your answer.

The stages must be in the correct order.

2

Stage 1

Stage 2

[Turn over



* X 8 6 2 7 5 0 1 1 9 *

4. (continued)

In preparing the top surface of the wooden blank before marking it out, a smoothing plane is used.

A diagram of the smoothing plane is shown below.

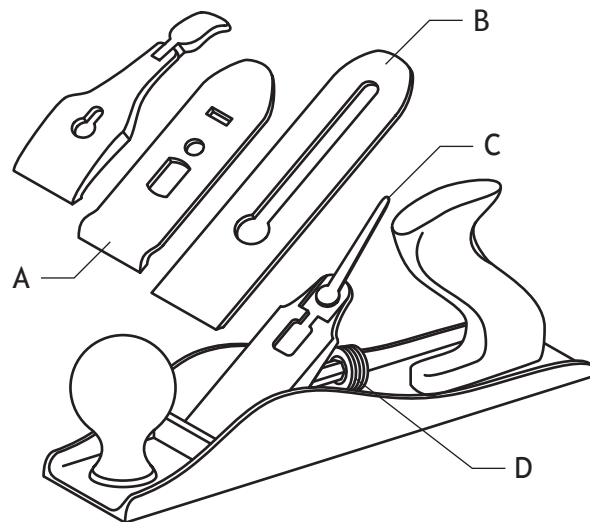

(b) Name parts A, B, C and D of the smoothing plane.

4

- A _____
- B _____
- C _____
- D _____

The attachment for mounting the bowl on the woodturning lathe is shown below.

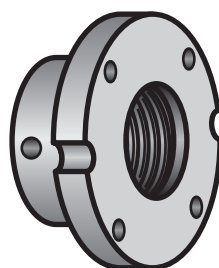

(c) Name this attachment.

1



4. (continued)

The attachment is mounted onto the woodturning lathe shown below.

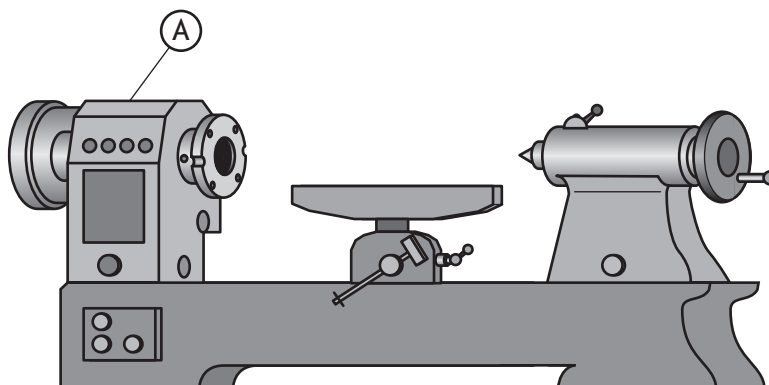

(d) Name part A shown above.

1

The tools shown are used to help shape the bowl on the woodturning lathe.

(e) Name the tools shown below.

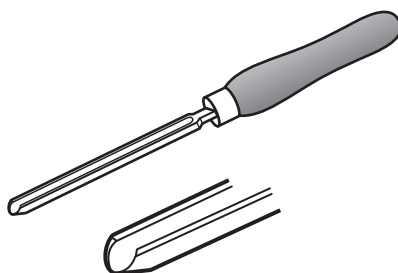

(i) _____

1

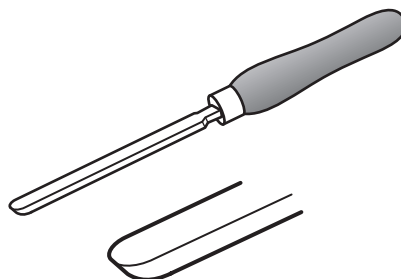

(ii) _____

1

[Turn over



* X 8 6 2 7 5 0 1 2 1 *

4. (continued)

When shaping wood on the woodturning lathe it is important for safety reasons to have the cutting tool at the correct height.

(f) Identify the correct tool height by ticking **one** of the boxes below.

1

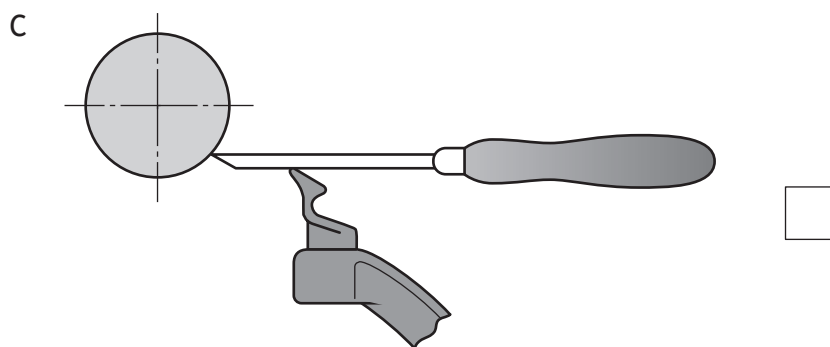
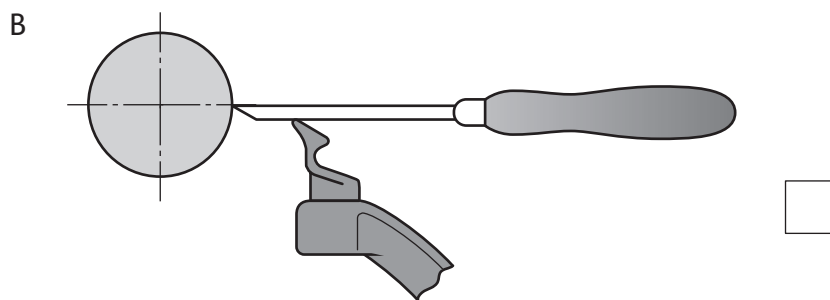
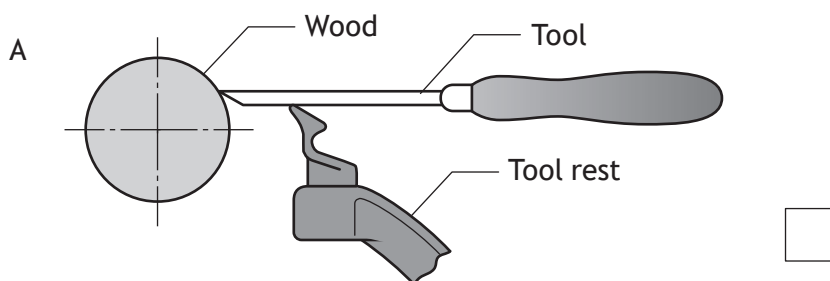

* X 8 6 2 7 5 0 1 2 2 *

4. (continued)

A varnish finish is to be applied to the bowl. The bowl is prepared for varnishing while still on the woodturning lathe.

- (g) Describe three actions that will ensure a good quality **surface finish** is achieved **before** applying the varnish.

3

1 _____

2 _____

3 _____

Health and safety in a workshop is a priority.

- (h) Describe three **personal** safety precautions you would take **before** switching on the woodturning lathe.

3

1 _____

2 _____

3 _____



* X 8 6 2 7 5 0 1 2 3 *

4. (continued)

The bowl is made from wood left over from another project.

- (i) Explain the reason why this is environmentally friendly.

1

[END OF QUESTION PAPER]



* X 8 6 2 7 5 0 1 2 4 *

MARKS

DO NOT
WRITE IN
THIS
MARGIN

ADDITIONAL SPACE FOR ANSWERS



* X 8 6 2 7 5 0 1 2 5 *

MARKS

DO NOT
WRITE IN
THIS
MARGIN

ADDITIONAL SPACE FOR ANSWERS



* X 8 6 2 7 5 0 1 2 6 *

[BLANK PAGE]

DO NOT WRITE ON THIS PAGE



* X 8 6 2 7 5 0 1 2 7 *

[BLANK PAGE]

DO NOT WRITE ON THIS PAGE



* X 8 6 2 7 5 0 1 2 8 *