

1. What do the following scales mean?

1:4 _____

5:1 _____

1:50 _____

3:4 _____

2. Write the scale to show the following sizes.

½ size _____

10x larger _____

200x smaller _____

1/3 size _____

3. Draw the 3rd angle projection symbol in the space below.

4. Add the following dimensions to the bracket shown to British Standards.

- i. The width of the top of the block.
- ii. The radius of the arc at the bottom.
- iii. The diameter of the larger circle.
- iv. The distance from the left hand side to the centre line of the first hole on the top.
- v. The height of the bracket.

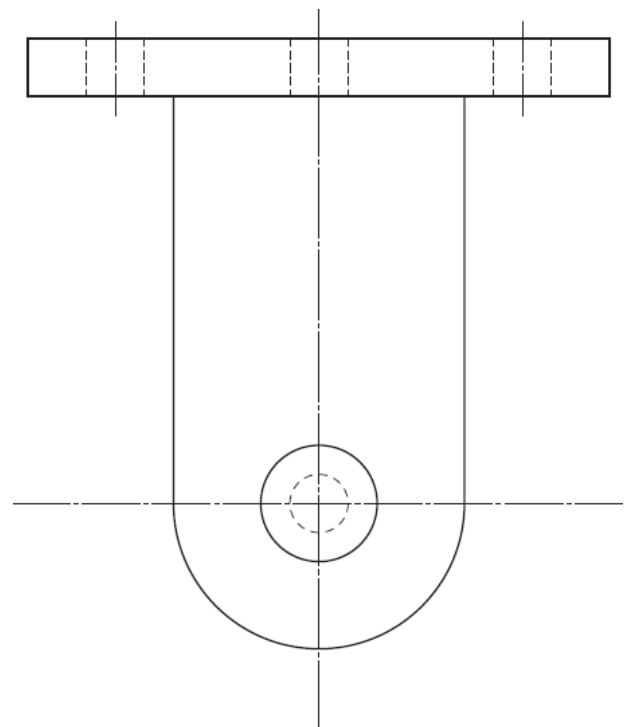

5. Below the Elevation, End Elevation and plan of a bracket are shown. Also shown are 12 Sectional Views of the bracket.

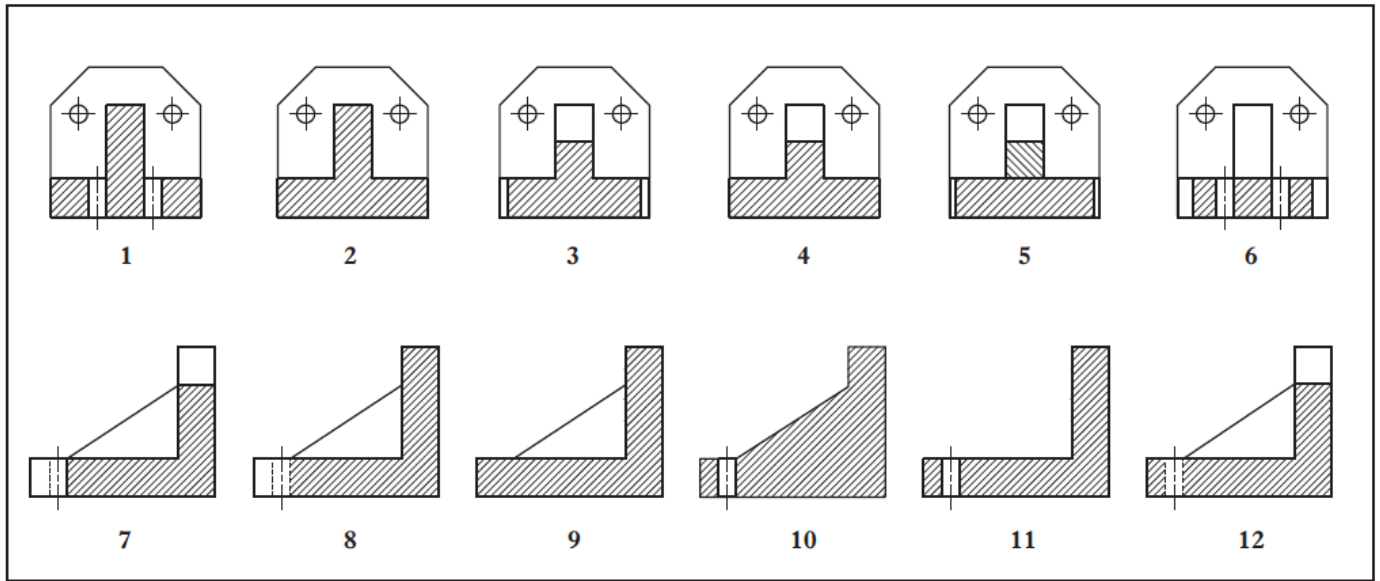

State which of the views above are the correct sections for **AA**, **BB**, **CC** and **DD**.

Section AA _____

Section BB _____

Section CC _____

Section DD _____

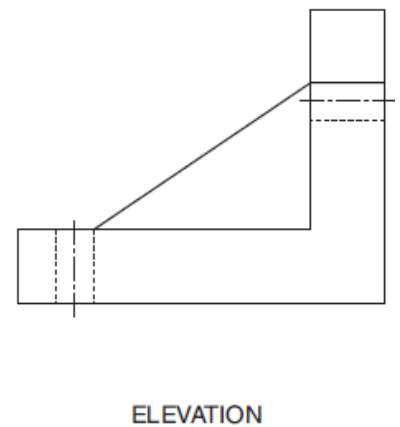
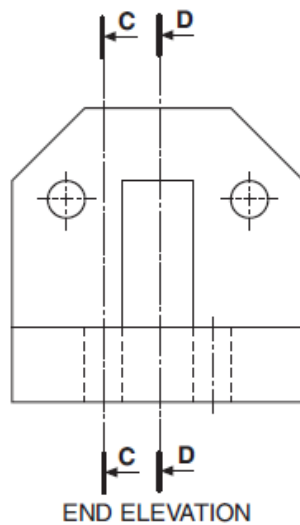
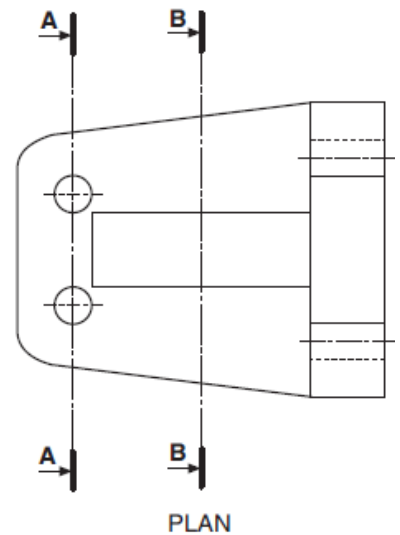

6. The Elevation, End Elevation and Plan of a coupling are shown below.

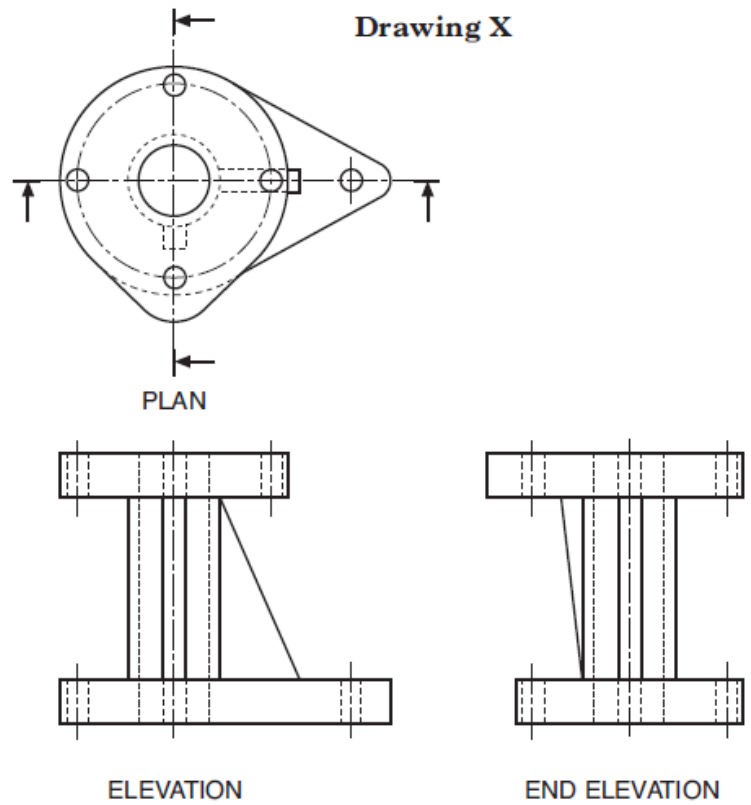

State which 2 of these pictorial views are of the coupling.

_____ and _____

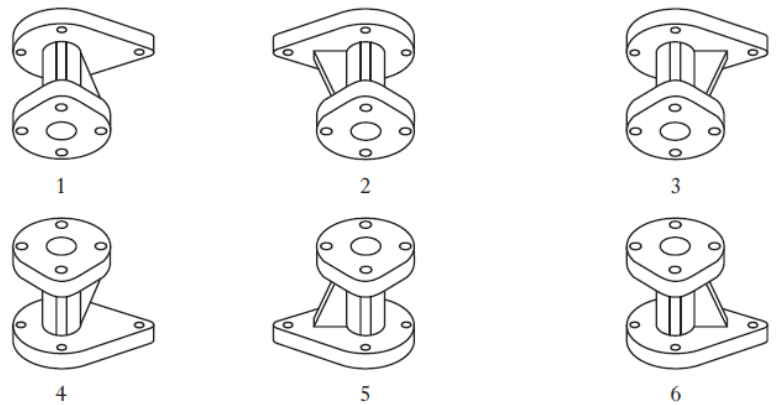

7. Name 3 different types of pictorial views that could be used to show the coupling.

8. Why are pictorial views of an object produced?

9. Below 8 Sectional Views of the coupling are shown.

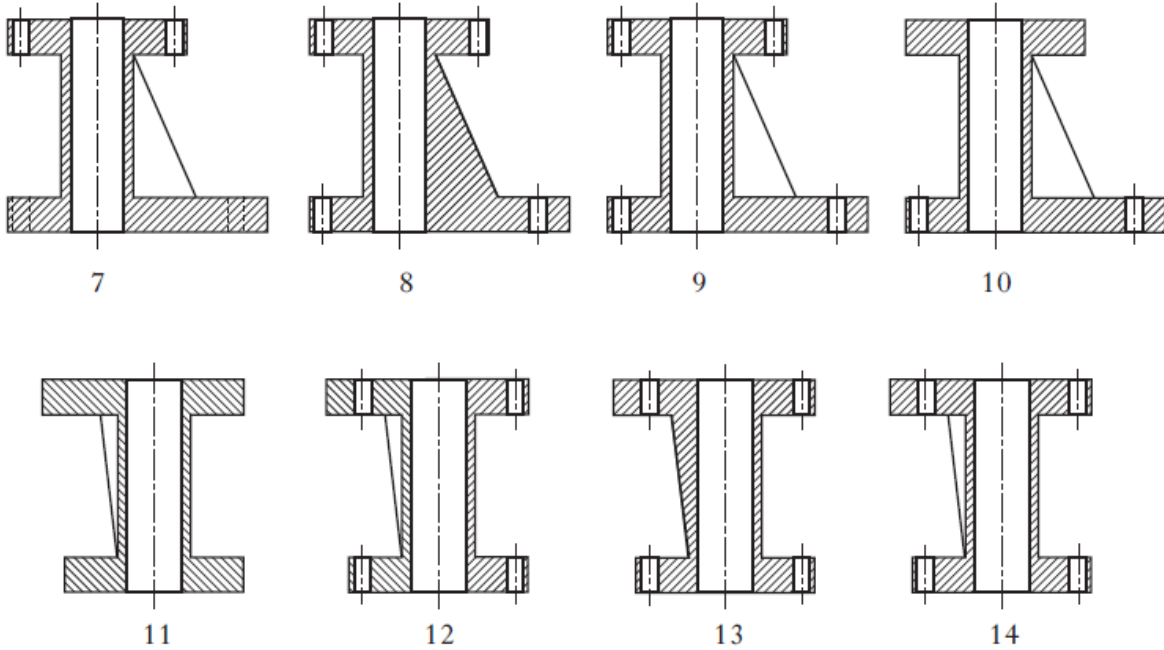

State which 2 are correct.

_____ and _____

10. Name the types of views shown here.

View 1 _____

View 2 _____

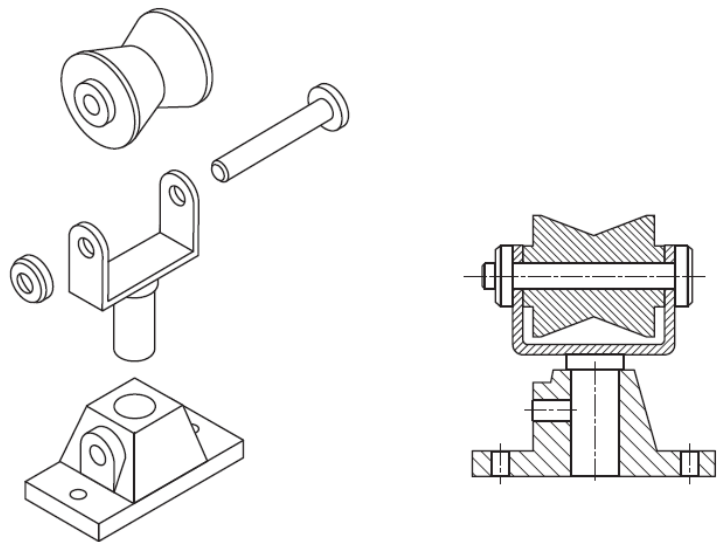

View 1

View 2

11. Explain why each of these drawings are produced.

View 1 _____

View 2 _____

12. State the names of the drawing types shown below.

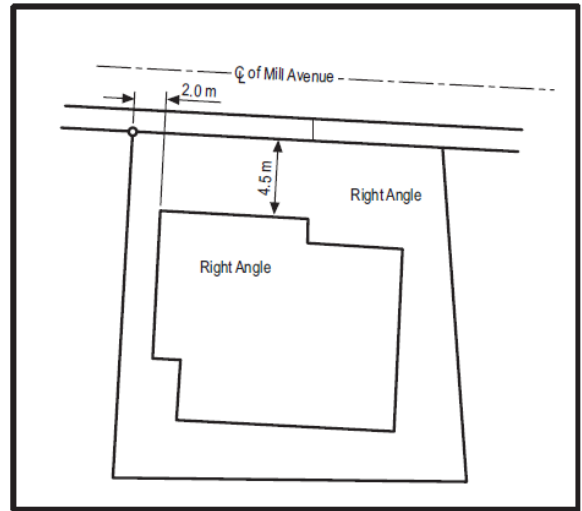
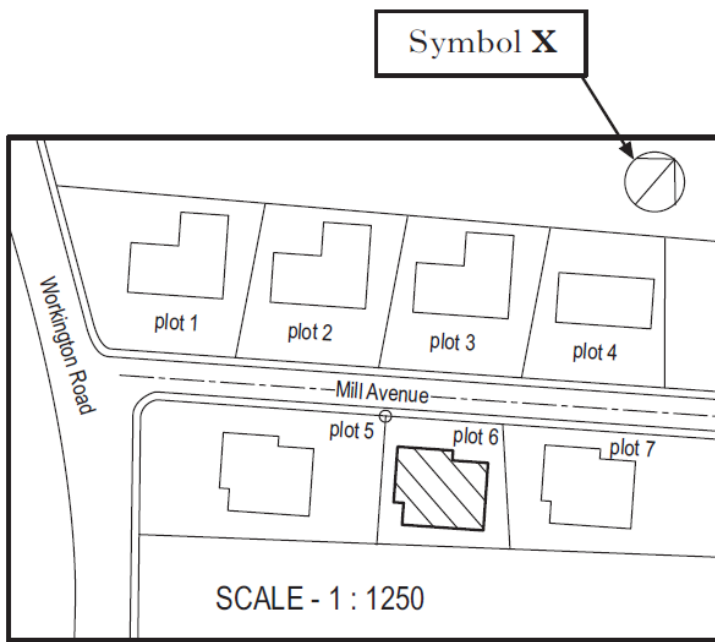

13. State the name of Symbol X.

14. In what part of a drawing set would you expect to find these types of drawings?

15. State the name the symbols shown on the floor plans.

- A _____
- B _____
- C _____
- D _____
- E _____
- F _____
- G _____
- H _____

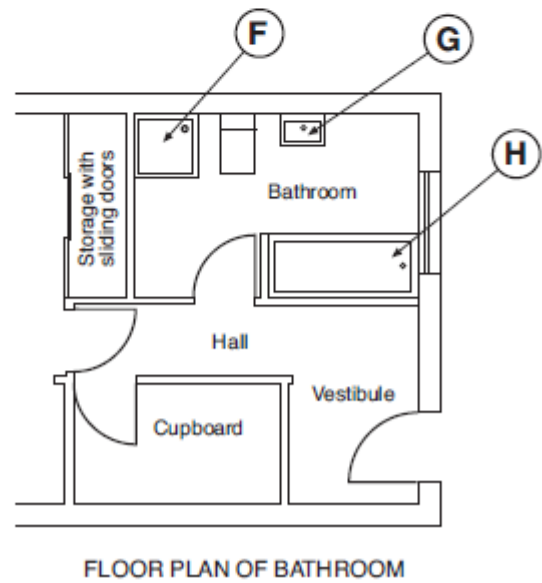
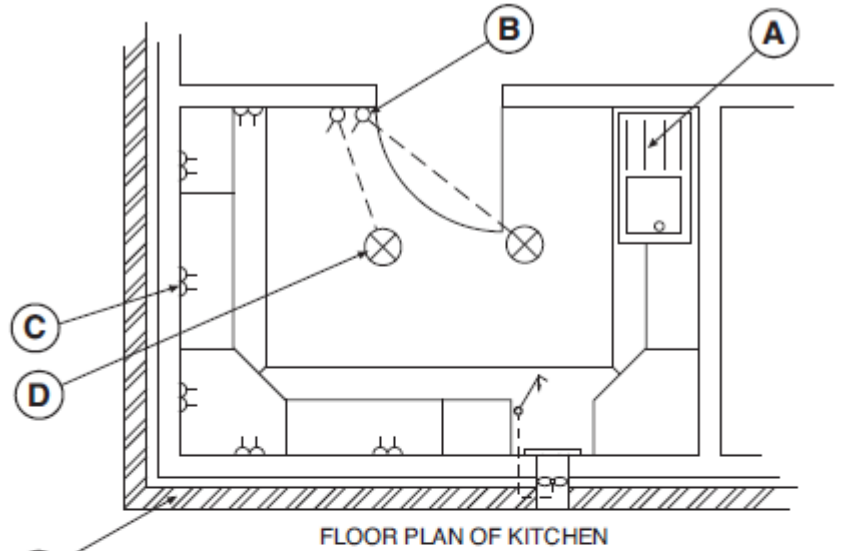

16. Using colour to help illustrate your answer, draw the symbols for the following.

Prohibition Sign

Warning Sign

Mandatory Sign

Safe Condition Sign

17. Describe what the following design elements mean.

Line

Mass

Shape

Colour

Size

18. Describe what the following design principles mean.

Balance

Contrast

Alignment

Proportion

Rhythm

Whitespace

Unity

19. A car sales company is looking to design a banner to go above their entrance to the sales area. They want the banner to be eye catching and stand out.

You must include in the banner the following things:

1. an image of a car,
2. the company name, "Cars R Us",
3. the sub heading, "we sell the cars you want"

Use some of the design elements and principles to design the banner below. Use colour in your answer.

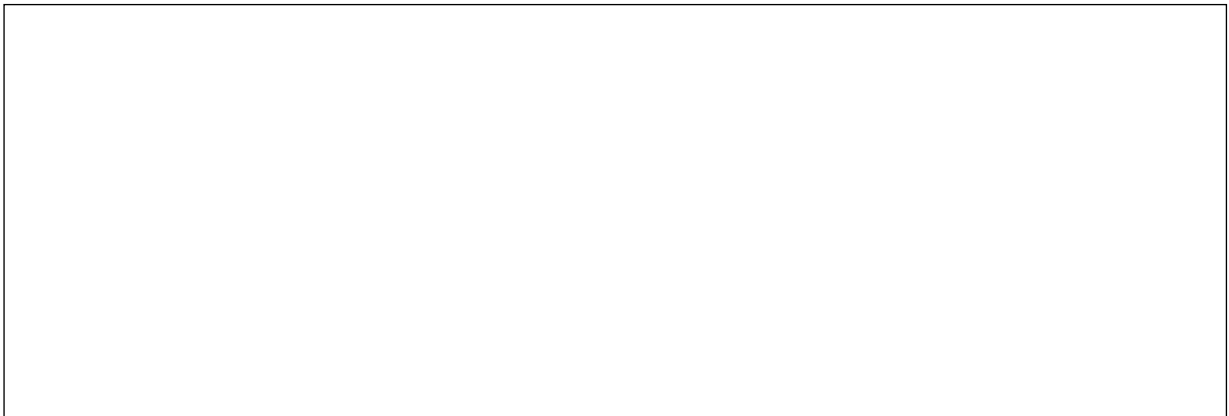

20. A mobile phone salesperson is ordering some business cards. These cards should be quite formal in their appearance.

The business card must include the following:

1. The business name, "MobFone",
2. The subheading, "ConneKting U",
3. The salespersons name and contact details. (make this up yourself)

Use some of the design elements and principles to design the business card below. Use colour in your answer.



21. Show one method of making the mug shown here stand out from a page. Use colour to do this and give a reason for selecting the colour you used.



Reason for colour choice -

22. Explain what is meant by the rule of thirds.

23. Add a title to the poster above in a suitable place. Use line and a suitable font to enhance the text you add.

24. State the effect has been applied to the cup below.

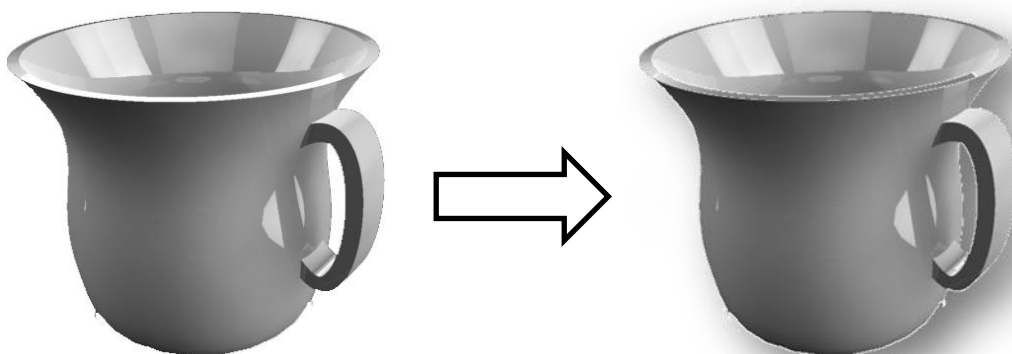

25. Name the elements shown in the magazine layout below.

Snowboard California

Snowboard California

California is uniquely positioned for winter sports. With the wind Jet Stream moving from west to east across the United States, a coastal mountain range, and the mighty Sierra Nevada range on the eastern border, California receives a lot of moisture in the winter and where the mountains rise from the valley floor—a consistent and persistent blanket of snow for everyone to enjoy. Since California has the tallest peak in the lower 48 (Mount Whitney), we often have the best skiing and snowboarding in the nation. All along the length of California, from Bear Mountain and Baldy Mountain in the south to Squaw Valley (home of the 1960 Winter Olympics) to Mt. Shasta Ski Resort, the towering Sierra Nevada Mountains provide the perfect combination of sunny weather, cool temperatures and fantastic snowfall to entice any snowman or snowwoman to enjoy their stay.

Types of Snowboarding

All of the various types of snowboarding are popular in California: freeride, freestyle, and freecarve or race. Freeride snowboarding is the most common type of snowboarding—it consists of just gliding down any hill or mountain. It can be as simple as a bunny hill for beginners and as complex and beautiful as aerial flips from snow hills and twists or the long, deep, slow turns of alpine snowboarding. Most riders will learn the basics of freeride before attempting any other style and 90% of riders will stay with freeride as their primary type of ride. Freestyle riders make use of manmade features, like jumps, rails, halfpipes and any other object that riders can use to perform any number of amazing feats of daring-do. One of the first tricks that any rider will learn is the “jib” or grind where a rider will slide on an object not made or covered with snow. The last type of riding is the freecarve style. Much like skiing, freecarve is most likely seen in race or slalom experiences. More often seen in European resorts, it is still extremely popular in California and can be done at any of the incredible resorts found in the Sierra Nevada Mountains.

Snow Resorts

Some of the most important snow resorts in the world are found in California. Squaw Valley was the host of the 1960 Olympic Games and is commonly considered one of the finest snow resorts. Mammoth Mountain holds some of the most challenging runs in the world—including the only quad-diamond run. Mt. Baldy is so connected to the southern California lifestyle that we regularly put together Surf/Turf/Snow packages where on spring days we present you with a surfing morning in Orange County, a mountain bike expedition on Saddleback Mountain, and finally a night skiing session in Mt. Baldy—all the features and experiences of California in one day.

Ski Packages

Besides the aforementioned Surf/Turf/Snow packages, we at Explore California have dozens of both a carte and all-in-one packages available for you to stretch your snowboarding legs. We can put you on any mountain you would like to carve down—even those without resorts. We have several fully “adventure skiing” packages where we put you in the wilderness of Donner Lake and you have to cross-country ski and snowboard you way back to civilization. Nothing says living like the ghosts of history and your own fear behind you. So join us—experience everything the Pacific coast has to offer and Explore Snowboarding in California.

Fact File

Fact The quick brown fox jumps over the lazy dog
 Name of Style Separated with a nonbreaking space

Wikipedia A good source for interesting tidbits about Joshua Tree
 Sidebar It's great to have a sidebar or two on the spread for variety—and more teaching points
 However I'm leaving out of things to say
 Times to just copy and paste what's here or for
 Fact The quick brown fox jumps over the lazy dog
 Name of Style Separated with a nonbreaking space

Wikipedia A good source for interesting tidbits about Joshua Tree
 Sidebar It's great to have a sidebar or two on the spread for variety—and more teaching points

8 Explore California 0900 1234 5678 www.explorecalifornia.com Explore California 9

26. In the snowboarding magazine layout, what effect does the line surrounding the page have?

27. How is Unity achieved in this magazine layout?

28. Give 2 advantages over manual methods that the use of computers has with producing DTP layouts.

29. What feeling is suggested by the use of the colour blue in the layout?

30. Why is yellow used in the header and the floating elements?

31. Using the appropriate terminology, describe what the effect of having the photographs at different angles is.

32. State the type of alignment that is used in the column text.

33. What DTP command was used to trace around the snowboarder's hand to remove the background from the original image?



34. Name 3 types of drawings that are produced at the Preliminary stage of developing a product?

35. What is the purpose of producing preliminary sketches?

36. Name 3 types of drawings that are produced at the Production stage of developing a product?

37. What role do production drawings play in producing a product?

38. Name 3 types of drawings that are produced at the Promotional stage of developing a product?

39. Why are promotional drawings produced?

40. What are the names of the line types and dimensioning symbols shown below?



i _____

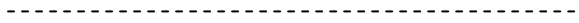

ii _____

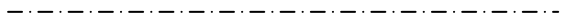

iii _____

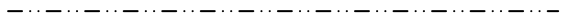

iv _____



v _____

41. Name the 3 mistakes in the dimension shown here.

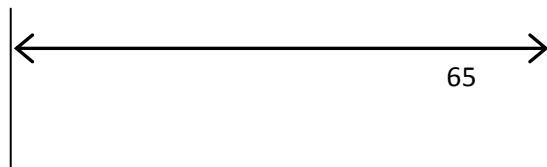

Mistake 1 _____

Mistake 2 _____

Mistake 3 _____

42. Draw the dimension properly in the space below.

43. Match the missing End Elevation of the hexagonal prism with the related Elevation and Plan.

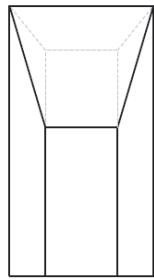

End Elevation

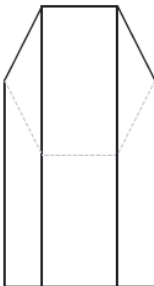

End Elevation

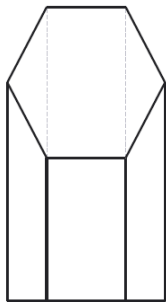

End Elevation

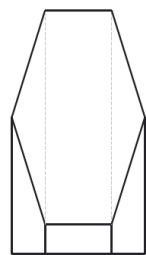

End Elevation

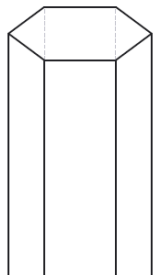

End Elevation

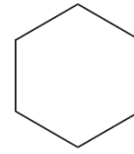

Plan

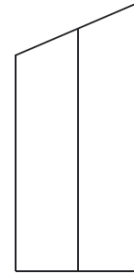

Elevation

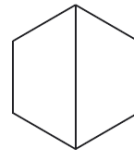

Plan

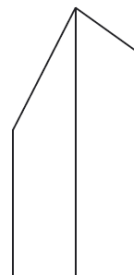

Elevation

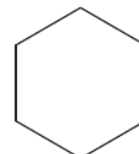

Plan

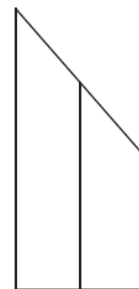

Elevation

44. Match the missing End Elevation of the pyramid with the related Elevation and Plan.

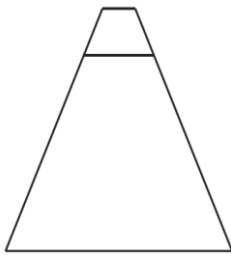

End Elevation

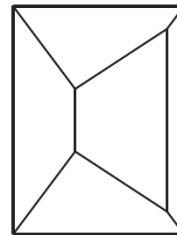

Plan

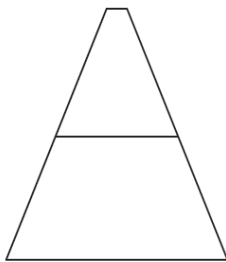

End Elevation



Elevation

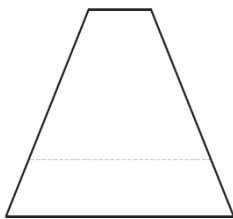

End Elevation

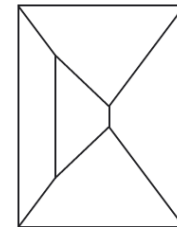

Plan

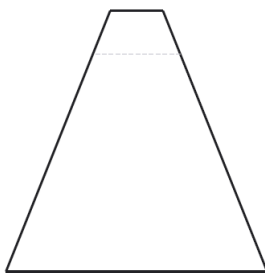

End Elevation



Elevation

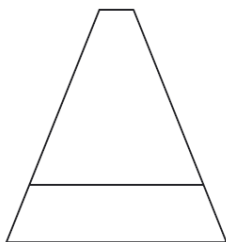

End Elevation

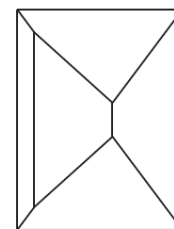

Plan

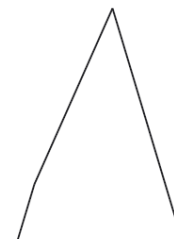

Elevation

45. Match the missing End Elevation of the cylinder with the related Elevation and Plan.

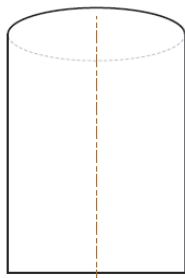

End Elevation

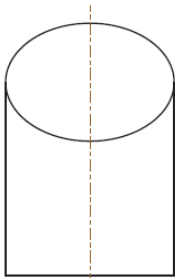

End Elevation

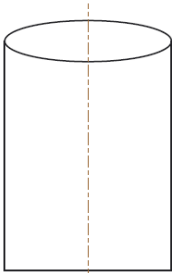

End Elevation

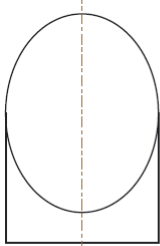

Elevation

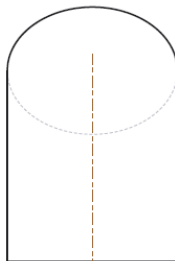

End Elevation

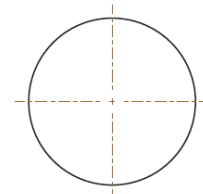

Plan

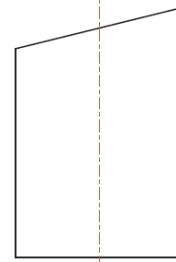

Elevation

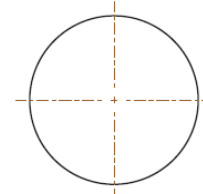

Plan

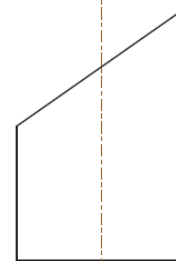

Elevation

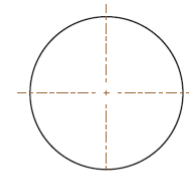

Plan

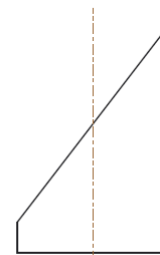

End Elevation

46. Match the missing End Elevation of the cone with the related Elevation and Plan.

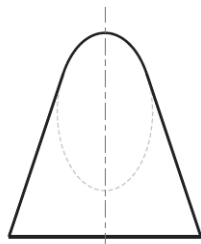

End Elevation

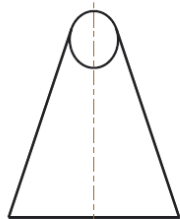

End Elevation

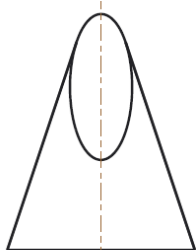

End Elevation

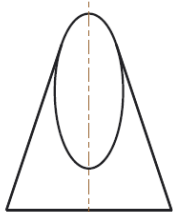

End Elevation

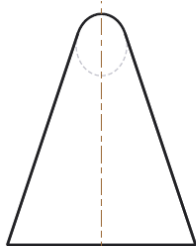

End Elevation

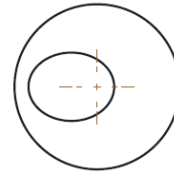

Plan

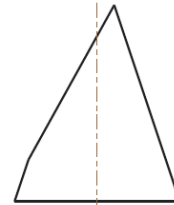

Elevation

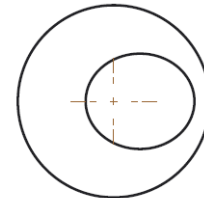

Plan

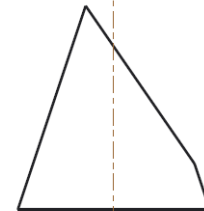

Elevation

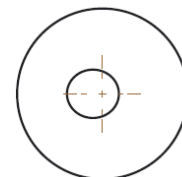

Plan



Elevation

You may be asked questions in your exam on the following topics. Use this as a guide to direct your studying and make sure that you ask any questions if you are unsure of any of these areas.

Component 1 — question paper

The question paper Component will require learners to draw on and apply knowledge and understanding (when responding to and interpreting given graphics or images and in theoretical situations or scenarios) of a sample from the topic areas listed below.

Topic area

Graphic types

Knowledge and understanding of the role of preliminary, production and promotional graphics in graphic communication activities.

Manual and computer-aided techniques

Knowledge and understanding of the role of manual and computer-aided techniques and processes, and their comparative merits when producing effective and informative graphic communications and solutions; activities including: describing processes, stages and generic commands applied or to be applied in producing graphic solutions; ranges, features and uses of graphic hardware and software, computer systems file management; digital input and output devices and the advantages and limitations of computer-aided design/draughting.

Skills in applying drawing standards, protocols and conventions

Knowledge, understanding and identification of recognised drawing standards, protocols and conventions commonly used in engineering and construction.
Including: line types (including dimension lines, centre line, hidden detail, cutting planes, fold lines), dimensioning (linear, radial, diameter, angular, square, across flats, across corners), and symbols for sections, hatching, symbols for building construction, and third angle projection system.
Building construction drawing: location plans, site plans, floor plans, sectional views and elevations.

Geometric shapes and forms, and everyday objects

Knowledge, understanding and skills in spatial awareness when interpreting geometric shapes and forms and/or those used in the communication of everyday objects. Common geometric forms and everyday objects consisting of: squares, rectangles, circles, hexagons, octagons, right prisms, pyramids, cones, and cylinders, partial or single cuts to these forms, components based on geometric forms, combinations of two components.

Views and techniques

Knowledge and understanding of the role, benefits and use of a variety of views and techniques in 2D, and 3D and pictorial formats, in communicating geometric shapes and forms and everyday objects.
Third angle orthographic projection of geometric forms and everyday objects in third angle projection, true lengths and

	<p>true shapes, surface developments, sectional views, assembly drawings, exploded isometric views of three parts. Pictorial views including isometric and oblique, containing curved parts and planometric.</p>
Layout elements and principles	<p>Knowledge and understanding of: the types of promotional graphics and their associated roles, and informational graphics. The interpretation and identification of the use of creative techniques for effective promotional graphics. Techniques including the use of: alignment, dominance, line, unity and depth, contrast, layout elements and principles; the use of colour, (warm, cool, contrast, harmony, advancing, receding, mood), reflection and shade. The use of a range of graphic manual and electronic modelling techniques in promotional graphics</p>
Computer-aided design/draughting	<p>Knowledge and understanding/interpretation of techniques and generic drawing and editing commands and terms including:</p> <p>Drawing tools: copy, zoom, mirror, trim-line, rotate, scale. Import and export.</p> <p>3D Modelling features: extrusion, revolved solids.</p> <p>3D Modelling edits: shell, subtraction, fillet, and chamfer. Assemblies. Techniques in the production of orthographic and pictorial work using computer-aided design/draughting, and the use and function of computer aided design/draughting libraries.</p>
Desktop publishing	<p>Knowledge, understanding/interpretation in explaining and justifying the use of desktop publishing techniques (DTP) and generic terms including: copy/cut/paste, text box, handles, colour fill, margin, single-page format, title, extended text, cropping, text wrap, flow text along a path, bleed, transparency, drop shadow, rotate, justification, paper sizing, reverse, column, gutter, caption, header and footer, line, grid, snap to grid, guidelines, snap to guidelines. The use and role of thumbnails and annotation.</p>
Graphic communication technology: impact on society and the environment	<p>Knowledge and understanding of the impact and influence of graphic communication activity on society and the environment — for example: the paperless office, use of recycled materials, computer-aided design/draughting as it supports manufacturing and other industries, DTP in marketing and promotional activities, remote working, and communication crossing international boundaries.</p>