



**National 5  
Physics**

# **Electricity & Energy exam questions**

**these questions have been collated from  
previous Standard Grade (Credit),  
Intermediate 2 and Higher Physics exams**

## DATA SHEET

### Speed of light in materials

Material	Speed in $\text{m s}^{-1}$
Air	$3.0 \times 10^8$
Carbon dioxide	$3.0 \times 10^8$
Diamond	$1.2 \times 10^8$
Glass	$2.0 \times 10^8$
Glycerol	$2.1 \times 10^8$
Water	$2.3 \times 10^8$

### Speed of sound in materials

Material	Speed in $\text{m s}^{-1}$
Aluminium	5200
Air	340
Bone	4100
Carbon dioxide	270
Glycerol	1900
Muscle	1600
Steel	5200
Tissue	1500
Water	1500

### Gravitational field strengths

	Gravitational field strength on the surface in $\text{N kg}^{-1}$
Earth	9.8
Jupiter	23
Mars	3.7
Mercury	3.7
Moon	1.6
Neptune	11
Saturn	9.0
Sun	270
Uranus	8.7
Venus	8.9

### Specific heat capacity of materials

Material	Specific heat capacity in $\text{J kg}^{-1} \text{ }^\circ\text{C}^{-1}$
Alcohol	2350
Aluminium	902
Copper	386
Glass	500
Ice	2100
Iron	480
Lead	128
Oil	2130
Water	4180

### Specific latent heat of fusion of materials

Material	Specific latent heat of fusion in $\text{J kg}^{-1}$
Alcohol	$0.99 \times 10^5$
Aluminium	$3.95 \times 10^5$
Carbon Dioxide	$1.80 \times 10^5$
Copper	$2.05 \times 10^5$
Iron	$2.67 \times 10^5$
Lead	$0.25 \times 10^5$
Water	$3.34 \times 10^5$

### Melting and boiling points of materials

Material	Melting point in $^\circ\text{C}$	Boiling point in $^\circ\text{C}$
Alcohol	-98	65
Aluminium	660	2470
Copper	1077	2567
Glycerol	18	290
Lead	328	1737
Iron	1537	2737

### Specific latent heat of vaporisation of materials

Material	Specific latent heat of vaporisation in $\text{J kg}^{-1}$
Alcohol	$11.2 \times 10^5$
Carbon Dioxide	$3.77 \times 10^5$
Glycerol	$8.30 \times 10^5$
Turpentine	$2.90 \times 10^5$
Water	$22.6 \times 10^5$

### Radiation weighting factors

Type of radiation	Radiation weighting factor
alpha	20
beta	1
fast neutrons	10
gamma	1
slow neutrons	3

$$E_p = mgh$$

$$d = vt$$

$$E_k = \frac{1}{2}mv^2$$

$$v = f\lambda$$

$$Q = It$$

$$T = \frac{1}{f}$$

$$V = IR$$

$$R_T = R_1 + R_2 + \dots$$

$$A = \frac{N}{t}$$

$$\frac{1}{R_T} = \frac{1}{R_1} + \frac{1}{R_2} + \dots$$

$$D = \frac{E}{m}$$

$$V_2 = \left( \frac{R_2}{R_1 + R_2} \right) V_s$$

$$H = Dw_R$$

$$\frac{V_1}{V_2} = \frac{R_1}{R_2}$$

$$\dot{H} = \frac{H}{t}$$

$$P = \frac{E}{t}$$

$$d = \bar{v}t$$

$$P = IV$$

$$s = \bar{v}t$$

$$P = I^2R$$

$$a = \frac{v-u}{t}$$

$$P = \frac{V^2}{R}$$

$$W = mg$$

$$E_h = cm\Delta T$$

$$F = ma$$

$$p = \frac{F}{A}$$

$$E_w = Fd$$

$$\frac{pV}{T} = \text{constant}$$

$$E_h = ml$$

$$p_1V_1 = p_2V_2$$

$$\frac{p_1}{T_1} = \frac{p_2}{T_2}$$

$$\frac{V_1}{T_1} = \frac{V_2}{T_2}$$

1. A mains electric fire has two heating elements which can be switched on and off separately. The heating elements can be switched on to produce three different heat settings: LOW, MEDIUM and HIGH. The fire also has an interior lamp which can be switched on to give a log-burning effect.



The circuit diagram for the fire is shown.

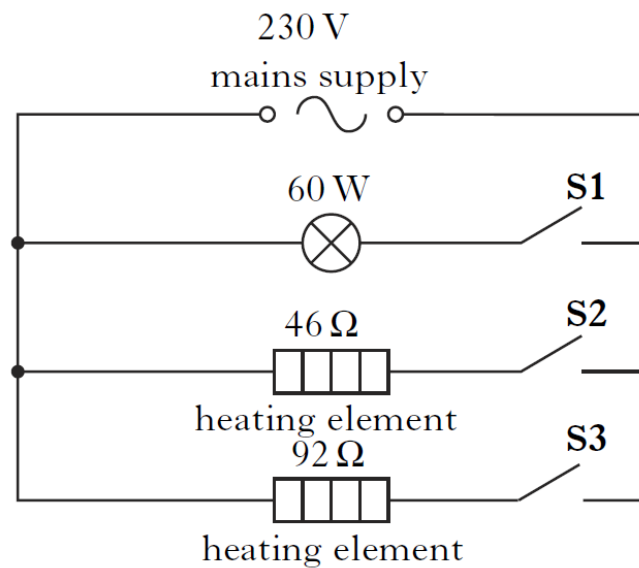

- (a) When switch **S1** is closed, the lamp operates at its stated rating of 60W.  
Calculate the current in the lamp. 3
- (b) Switch **S1** is opened and switches **S2** and **S3** are closed.
- (i) Calculate the combined resistance of both heating elements. 3
- (ii) Calculate the total power developed in the heating elements when **S2** and **S3** are closed. 3
- (iii) State and explain which switch or switches would have to be closed to produce the **LOW** heat setting. 2

2. An automatic hand dryer used in a washroom is shown in the diagram below.

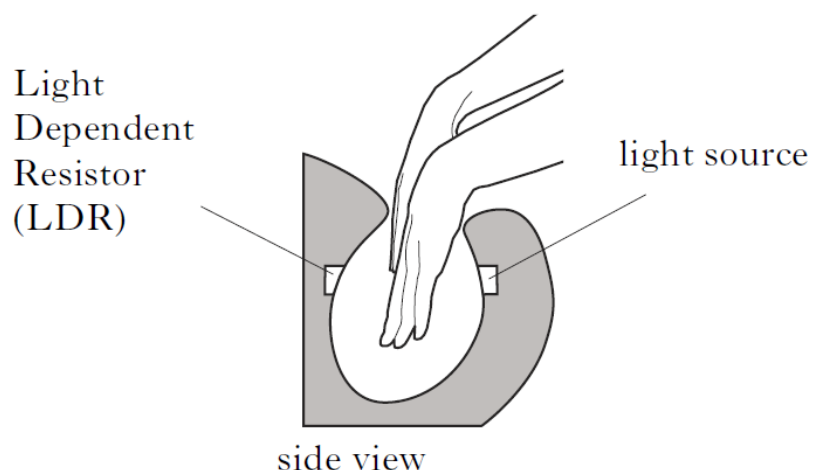

Inserting hands into the dryer breaks a light beam, this is detected using a light dependent resistor (LDR). The LDR is part of a switching circuit which activates the dryer when hands are inserted. Part of the circuit for the hand dryer is shown.

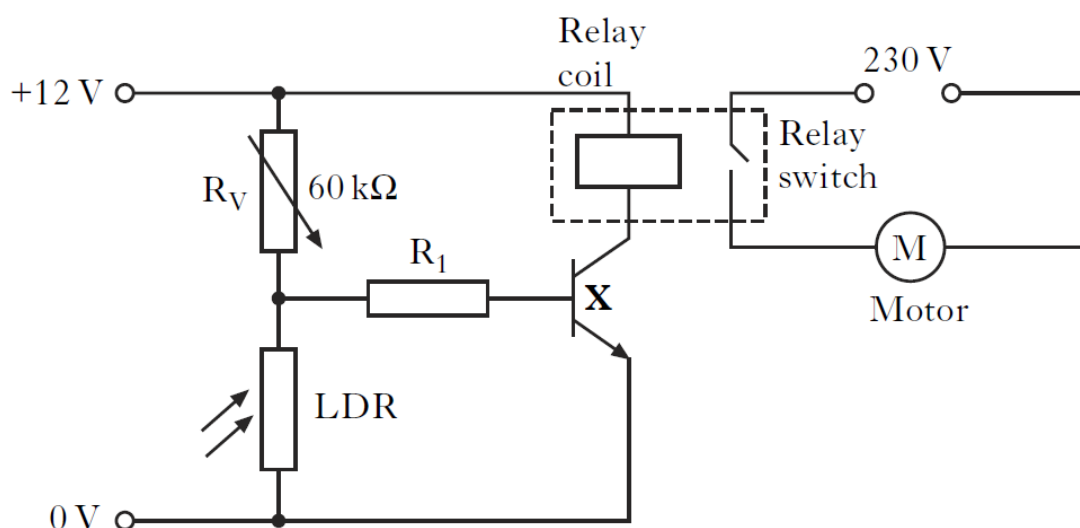

- (a) The variable resistor  $R_V$  is set to a resistance of  $60 \text{ k}\Omega$ .  
Calculate the voltage across the LDR when its resistance is  $4 \text{ k}\Omega$ . 3
- (b) Name component X in the circuit diagram. 1
- (c) Explain how this circuit operates to activate the motor in the dryer when the light level falls below a certain value. 4

3. A steam cleaner rated at 2 kW is used to clean a carpet. The water tank is filled with 1.6 kg of water at 20 °C. This water is heated until it boils and produces steam. The brush head is pushed across the surface of the carpet and steam is released.

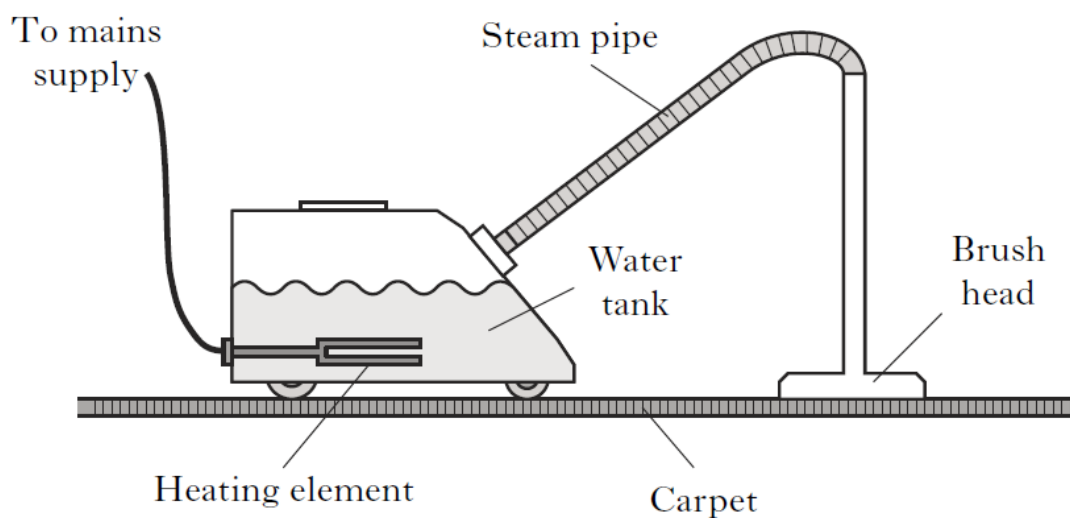

- (a) Calculate how much heat energy is needed to bring this water to its boiling point of 100 °C. 4
- (b) After the steam cleaner has been used for a period of time, 0.9 kg of boiling water has changed into steam.
- (i) Calculate how much heat energy was needed to do this. 4
- (ii) Calculate how long it would take to change this water into steam. 3

4. A small submersible pump is used in a garden water fountain. The pump raises 25 kg of water each minute from a reservoir at ground level. The water travels through a plastic tube and reaches a height of 1.2m above ground level.

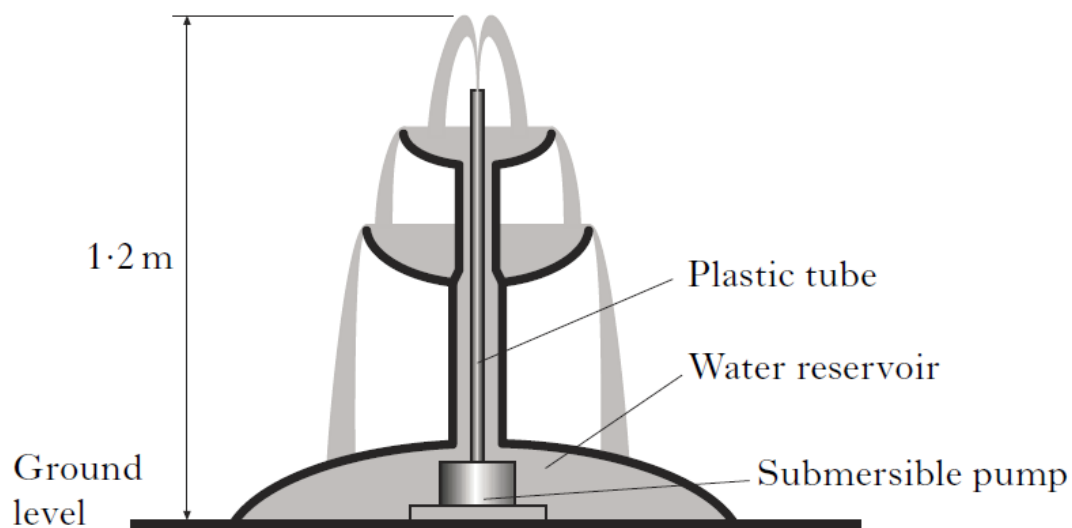

- (a) Calculate how much gravitational potential energy the water gains each minute.

3

5. An experiment was carried out to determine the specific heat capacity of water. The energy supplied to the water was measured by a joulemeter.

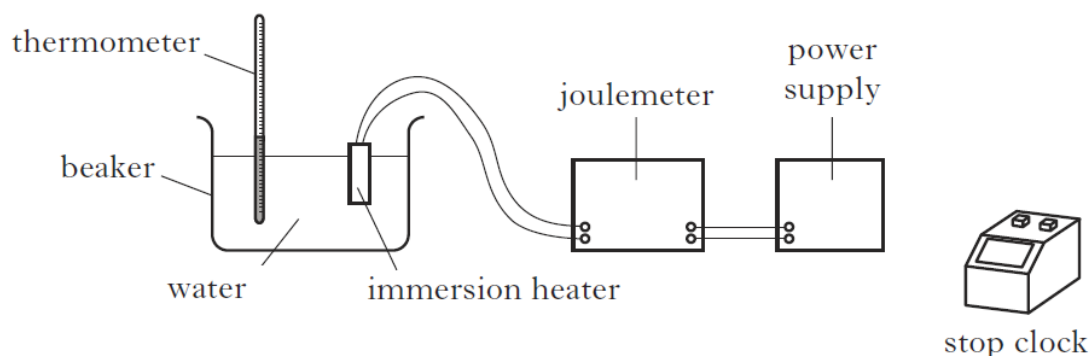

The following data was recorded.

Initial temperature of the water = 21 °C.

Final temperature of the water = 33 °C.

Initial reading on the joulemeter = 12 kJ.

Final reading on the joulemeter = 120 kJ.

Mass of water = 2.0 kg.

Time = 5 minutes.

- |     |       |  |   |
|-----|-------|--|---|
| (a) | (i)   | Calculate the change in temperature of the water.  | 1 |
|     | (ii)  | Calculate the energy supplied by the immersion heater.   | 1 |
|     | (iii) | Calculate the value for the specific heat capacity of water obtained from this experiment.   | 3 |
| (b) | (i)   | The accepted value for the specific heat capacity of water is quoted in the table in the Data Sheet. Explain the difference between the accepted value and the value obtained in the experiment. | 2 |
|     | (ii)  | How could the experiment be improved to reduce this difference?  | 1 |
| (c) |       | Calculate the power rating of the immersion heater.  | 3 |



6. Part of a circuit is shown below.

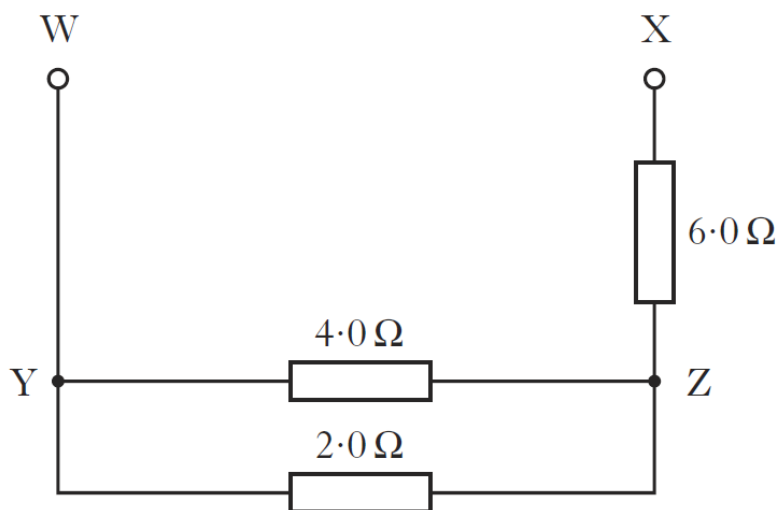

- (a) Calculate the total resistance between points Y and Z. 3
- (b) Calculate the total resistance between points W and X. 3
- (c) Calculate the voltage across the  $2.0\ \Omega$  resistor when the current in the  $4.0\ \Omega$  resistor is  $0.10\ \text{A}$ . 3
7. A student has two electrical power supplies. One is an a.c. supply and the other is a d.c. supply.

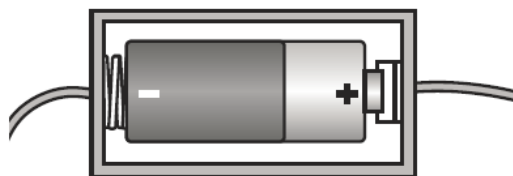
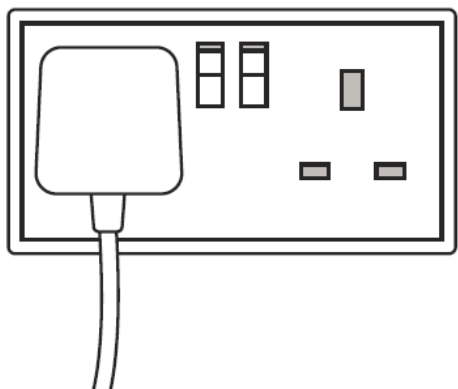

- (a) Explain a.c and d.c. in terms of electron flow in a circuit.

8. Light emitting diodes (LEDs) are often used as on/off indicators on televisions and computers.

An LED is connected in a circuit with a resistor R.

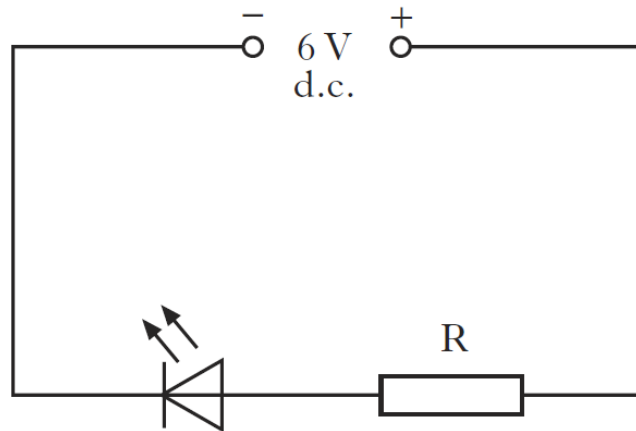

- (a) State the purpose of resistor R. 1
- (b) The LED is rated at 2 V, 100 mA. Calculate the resistance of resistor R. 4
- (c) Calculate the power developed by resistor R when the LED is working normally. 3

9. An engine applies a force of 2000 N to move a lorry at a constant speed.  
 The lorry travels 100 m in 16 s.  
 The power developed by the engine is

- A 0.8 W
- B 12.5 W
- C 320 W
- D 12 500 W
- E 3 200 000 W.

10. Which row in the table identifies the following circuit symbols?

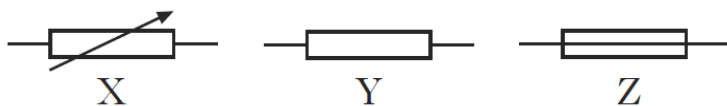

	<i>Symbol X</i>	<i>Symbol Y</i>	<i>Symbol Z</i>
A	fuse	resistor	variable resistor
B	fuse	variable resistor	resistor
C	resistor	variable resistor	fuse
D	variable resistor	fuse	resistor
E	variable resistor	resistor	fuse

11. Which graph shows how the potential difference  $V$  across a resistor varies with the current  $I$  in the resistor?

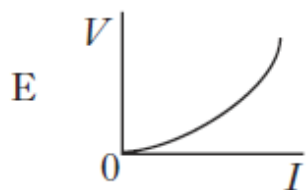
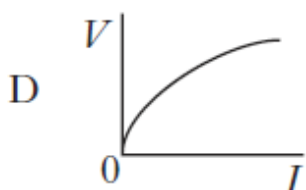
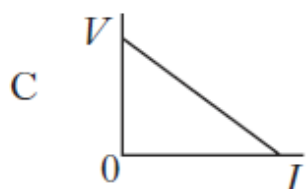
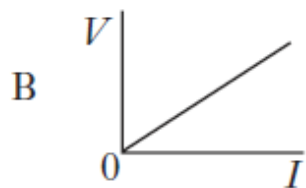
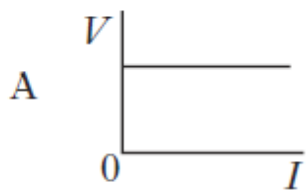

12. A circuit is set up as shown.

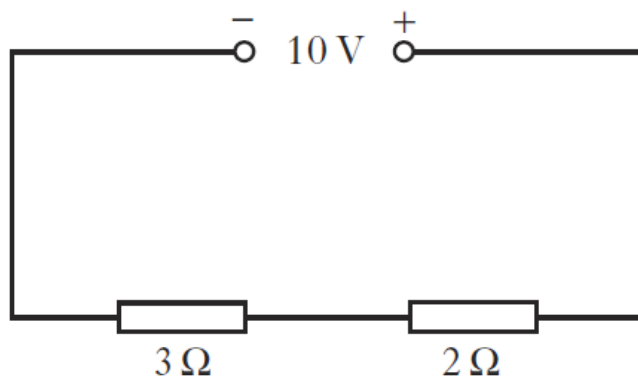



The potential difference across the  $2\ \Omega$  resistor is

- A 4 V
  - B 5 V
  - C 6 V
  - D 10 V
  - E 20 V.
13. A student makes the following statements about electrical supplies.
- I The frequency of the mains supply is 50 Hz.
  - II The quoted value of an alternating voltage is less than its peak value.
  - III A d.c supply and an a.c. supply of the same quoted value will supply the same power to a given resistor.

Which of the following statements is/are correct?

- A I only
- B II only
- C III only
- D I and II only
- E I, II and III

14. Which of the following is the circuit symbol for an NPN transistor?

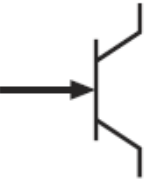
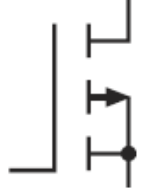
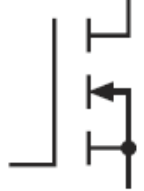
A	
B	
C	
D	
E	

15. A student sets up a circuit to operate two identical 12 V, 36 W lamps from a 48 V supply.

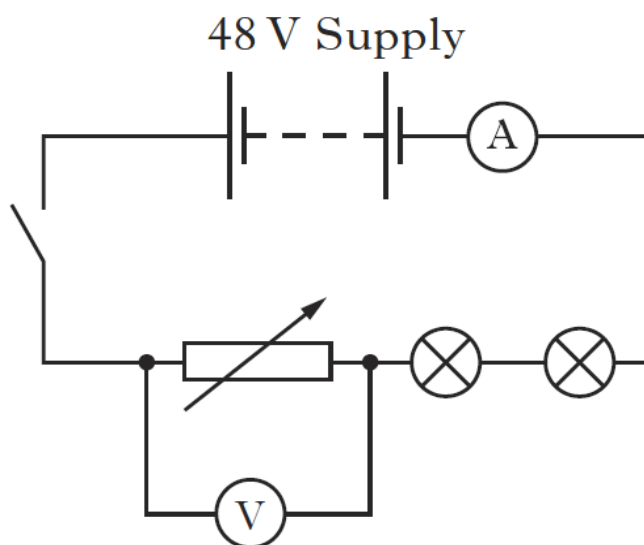

- (a) When the switch is closed, the lamps operate at their correct power rating. Calculate:
- |  |   |
|--|---|
| (i) the reading on the ammeter;                | 3 |
| (ii) the reading on the voltmeter;             | 1 |
| (iii) the resistance of the variable resistor. | 3 |

## 15. (continued)

- (b) The student sets up a second circuit using a 12 V supply and the same lamps. Each lamp has a resistance of  $4\ \Omega$ . The resistance of the variable resistor is set to  $6\ \Omega$ .

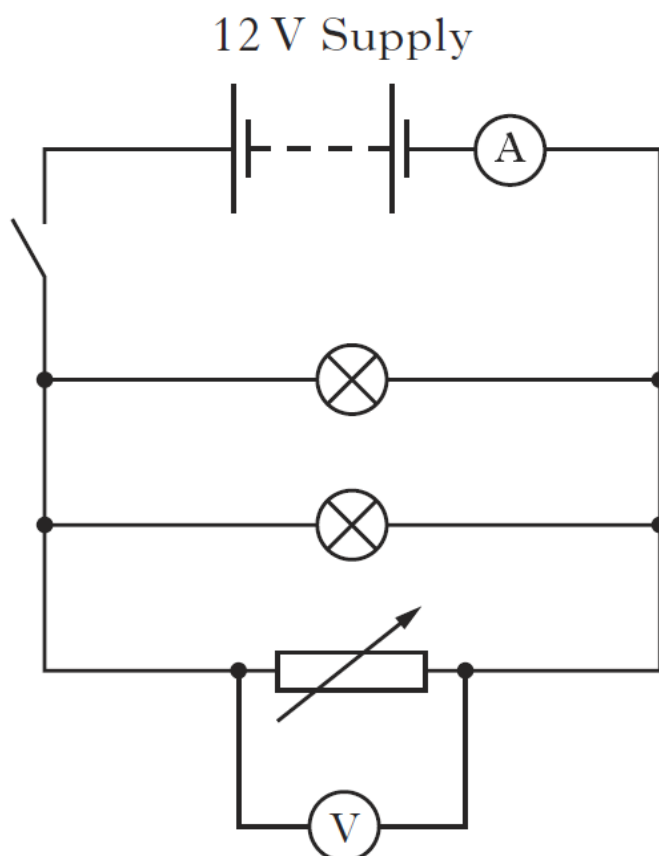

- (i) Calculate the total resistance of this circuit. 3
- (ii) The variable resistor is now removed from the circuit.
- (A) What happens to the reading on the ammeter? 1
- (B) Justify your answer. 1



16. A bank has an alarm system which can be triggered by the cashiers who work behind the counter.



The alarm can be triggered when the cashier removes an imitation £20 note from a cash drawer.

A circuit, inside the cash drawer, contains an LED which is directed at an LDR as shown. When the cashier removes the imitation £20 note the alarm is triggered.

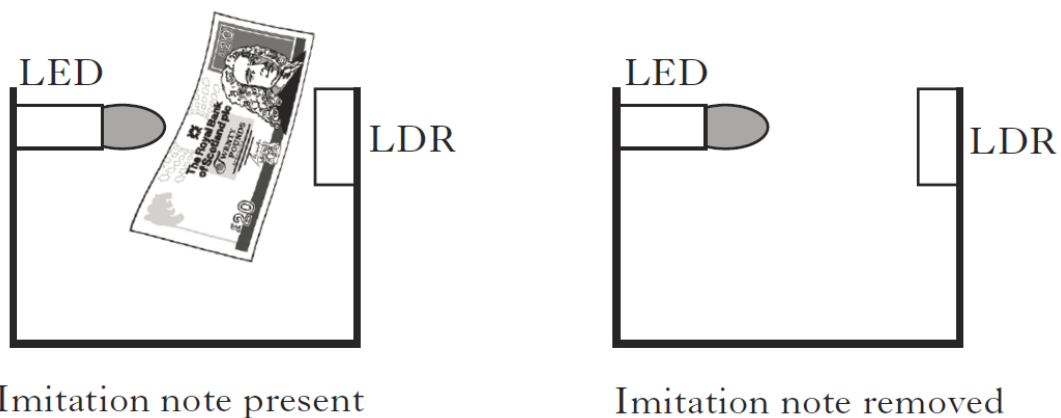

The table shows the resistance of the LDR in different light conditions.

<i>Imitation £20 note</i>	<i>Resistance (kΩ)</i>
present	24
removed	2

## 16. (continued)

Part of the cash drawer circuit is shown below.

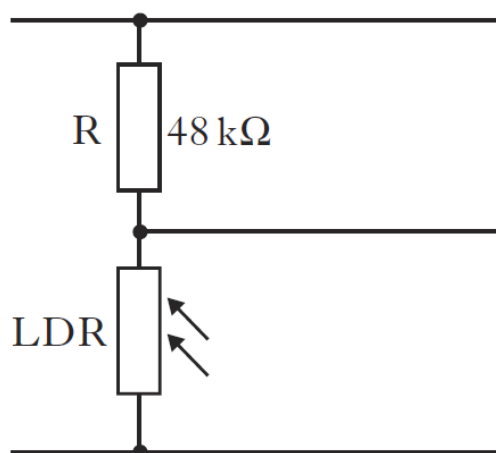

- (a) When the imitation £20 note is removed from the drawer, the voltage across the LDR is  $0.36\text{ V}$ .

Calculate the voltage across R.

3

- (b) The alarm has a loudspeaker as an output device, which emits a sound when the alarm is triggered.

The loudspeaker has a resistance of  $48\ \Omega$  and a power of  $3.0\text{ W}$ .

Calculate the voltage across the loudspeaker when it sounds.

3

17. A laptop is plugged into the mains to charge. A blue LED flashes to indicate that the laptop is charging.

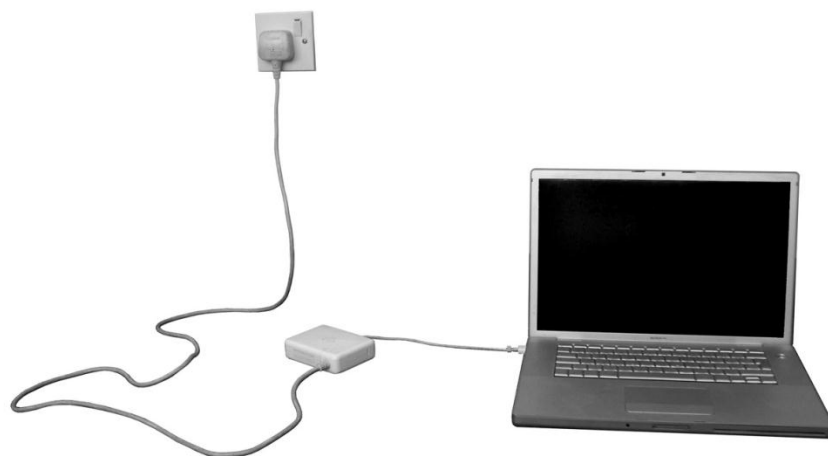

The LED is connected to a pulse generator.  
The circuit diagram for the pulse generator is shown.

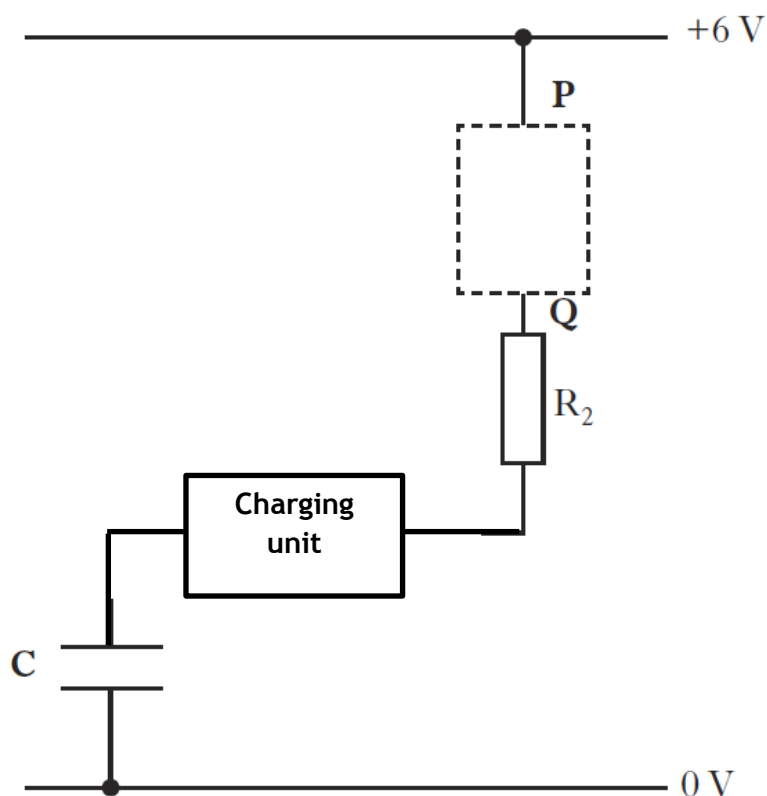

- |     |   |   |
|-----|---|---|
| (a) | (i) Complete the diagram to show the LED correctly connected between P and Q.   | 1 |
|     | (ii) State the purpose of resistor $R_2$ connected in series with the LED.  | 1 |
|     | (iii) When lit, the current in the LED is 15 mA and the voltage across it is 1.2 V. Calculate the value of resistor $R_2$ in series with the LED. | 4 |

18. Model power transmission lines are set up to demonstrate how electricity is distributed from a power station to consumers.

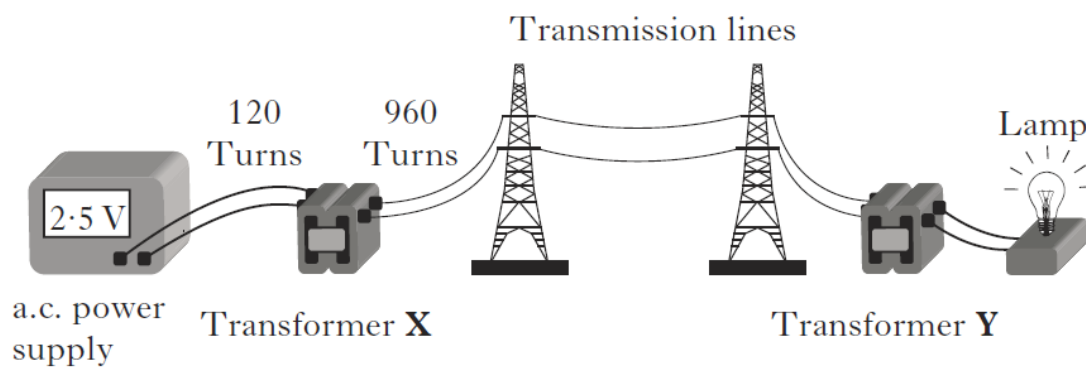

The current in the transmission lines is 200 mA.

The transmission lines have a total resistance of  $20 \Omega$ .

Calculate the total power loss in these transmission lines.

19. A manufacturer has developed an iron with an aluminium sole plate. A technician has been asked to test the iron.



The technician obtains the following data for one setting of the iron.

Starting temperature of sole plate:	24 °C
Operating temperature of the sole plate:	200 °C
Time for iron to reach the operating temperature:	35 s
Power rating of the iron:	1.5 kW
Operating voltage:	230 V
Specific Heat Capacity of Aluminium:	902 J kg <sup>-1</sup> °C <sup>-1</sup>

- (a) Calculate how much electrical energy is supplied to the iron in this time. 3
- (b) Calculate the mass of the aluminium sole plate. 3
- (c) The actual mass of the aluminium sole plate is less than the value calculated in part (b) using the technician's data.  
Give **one** reason for this difference. 1
20. An electrical motor raises a crate of mass 500 kg through a height of 12 m in 4 s.  
The minimum power rating of the motor is
- A 1.25 kW  
B 1.5 kW  
C 15 kW  
D 60 kW  
E 240 kW.

21. A student sets up the circuits shown.  
In which circuit will both LEDs be lit?

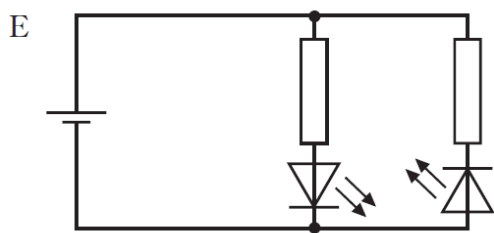
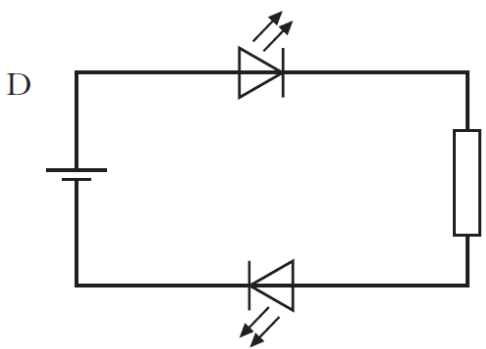
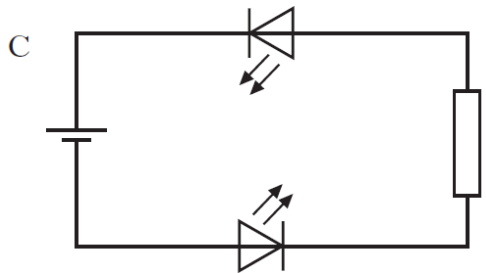
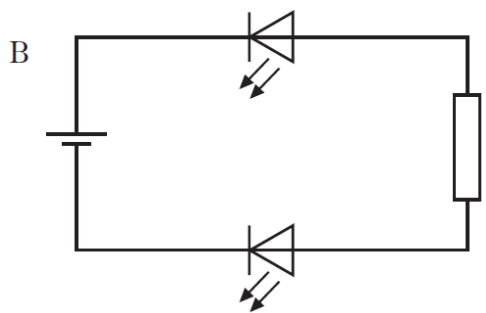
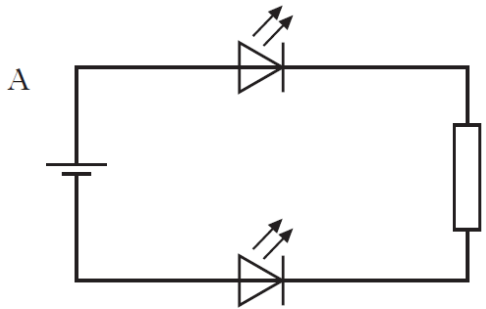

22. The current in an  $8\ \Omega$  resistor is 2 A.  
The charge passing through the resistor in 10 s is
- A 4 C
  - B 5 C
  - C 16 C
  - D 20 C
  - E 80 C.
23. Which of the following statements is/ are correct?
- I In an a.c. circuit the direction of the current changes regularly.
  - II In a d.c. circuit positive charges flow in one direction only.
  - III In an a.c. circuit the size of the current varies with time.
- A I only
  - B II only
  - C I and II only
  - D I and III only
  - E I, II and III

24. A student reproduces Galileo's famous experiment by dropping a solid copper ball of mass  $0.50 \text{ kg}$  from a balcony on the Leaning Tower of Pisa.

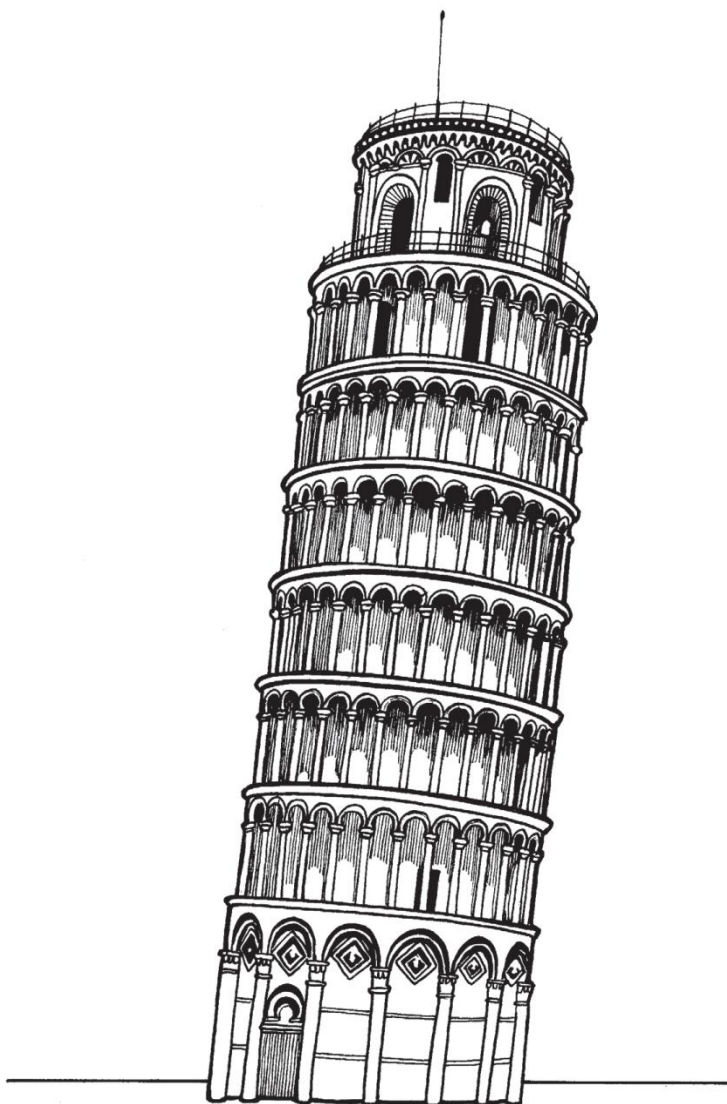

- (a) (i) The ball is released from a height of  $19.3 \text{ m}$ .  
Calculate the gravitational potential energy lost by the ball. 3
- (ii) Assuming that all of this gravitational potential energy is converted into heat energy in the ball, calculate the increase in the temperature of the ball on impact with the ground. 3
- (iii) Is the actual temperature change of the ball greater than, the same as or less than the value calculated in part (a)(ii)?  
You **must** explain your answer. 3
- (b) The ball was made by melting  $0.50 \text{ kg}$  of copper at its melting point. Calculate the amount of heat energy required for this. 4



25. A resistor is labelled: “ $10\ \Omega \pm 10\%$ , 3 W”.

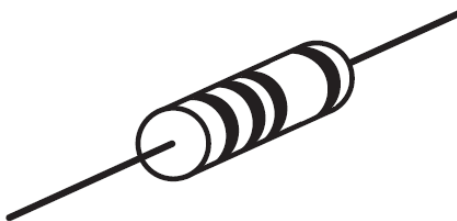

This means that the resistance value could actually be between  $9\ \Omega$  and  $11\ \Omega$ .

- (a) A student decides to check the value of the resistance.  
Draw a circuit diagram, including a 6 V battery, a voltmeter and an ammeter, for a circuit that could be used to determine the resistance. 3
- (b) Readings from the circuit give the voltage across the resistor as 5.7 V and the current in the resistor as 0.60 A.  
Use these values to calculate the resistance. 3
- (c) During this experiment, the resistor becomes very hot and gives off smoke.  
Explain why this happens.  
You **must** include a calculation as part of your answer. 4
- (d) The student states that **two** of these resistors would not have overheated if they were connected together in parallel with the battery.  
Is the student correct?  
Explain your answer. 2

26. The circuit shown switches a warning lamp on or off depending on the temperature.

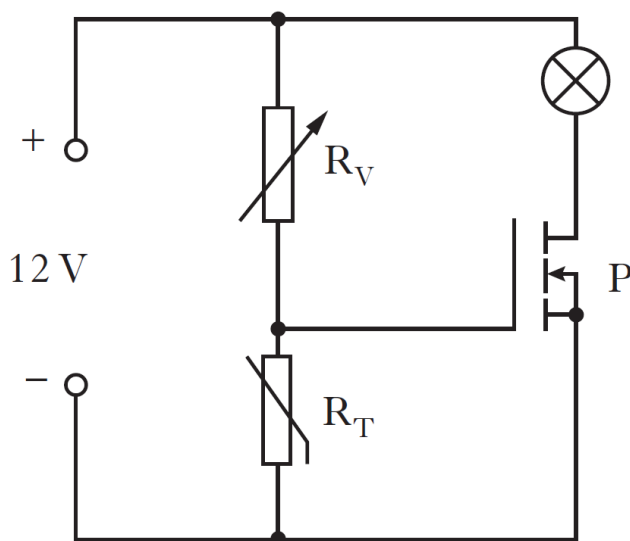

- (a) Name component P. 1
- (b) As the temperature increases the resistance of thermistor  $R_T$  decreases. What happens to the voltage across  $R_T$  as the temperature increases? 1
- (c) When the voltage applied to component P is equal to or greater than 2.4 V, component P switches on and the warning lamp lights.  
 $R_V$  is adjusted until its resistance is  $5600 \Omega$  and the warning lamp now lights.  
 At this point calculate:
- (i) the voltage across  $R_V$ ; 1
- (ii) the resistance of  $R_T$ . 3
- (d) The temperature of  $R_T$  now decreases.  
 Will the lamp stay on or go off?  
 You **must** explain your answer. 3

27. A house owner installs a heating system under the floor of a new conservatory. Three heating mats are fitted. The mats contain resistance wires and are laid underneath the floor. Each mat is designed to operate at 230 V and has a power of 300 W.

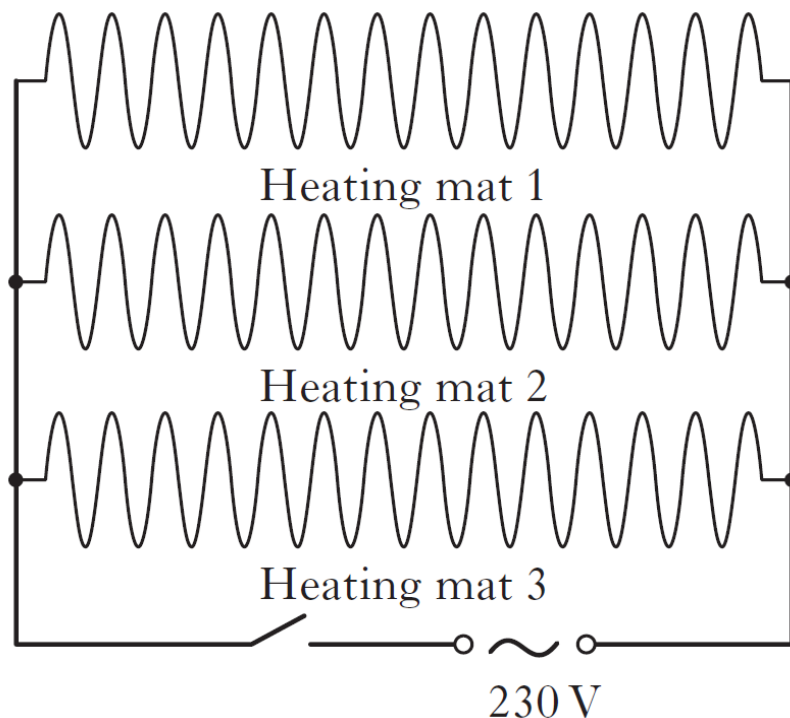

- (a) State how the three heating mats are connected together to operate at their correct voltage. 1
- (b) Calculate the current in each heating mat when switched on. 3
- (c) Calculate the total resistance of the heating system when all three mats are switched on. 3

28. A student has designed a simple electric cart. The cart uses 2 large 12 V rechargeable batteries to drive an electric motor. The speed of the cart is controlled by adjusting a variable resistor.

The circuit diagram for the cart is shown.

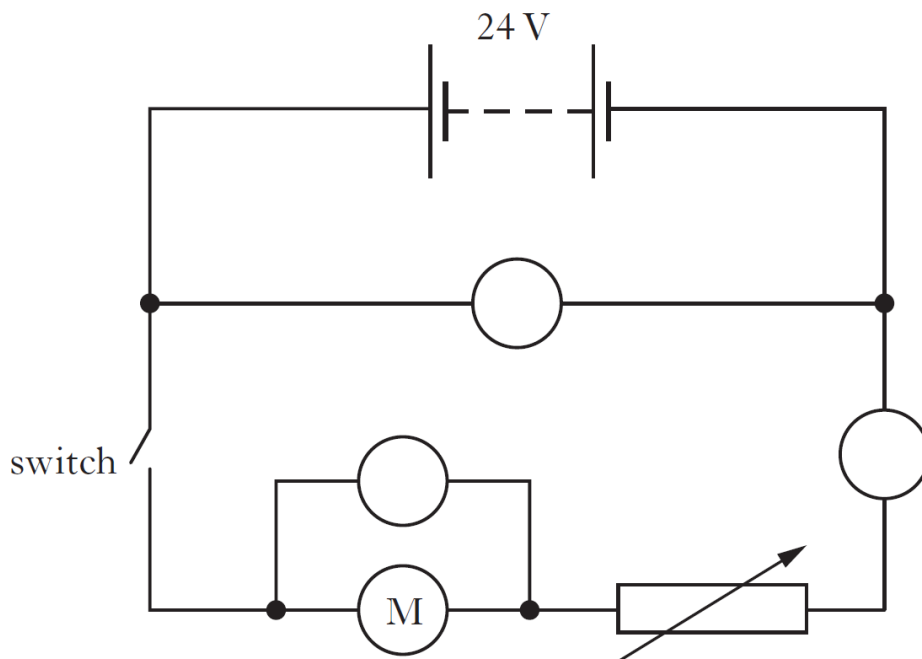

- (a) The circuit contains two voltmeters and an ammeter.  
Complete the diagram by labelling the meters. 1
- (b) When the cart is moving at a certain speed the voltage across the motor is 18 V and the resistance of the variable resistor is  $2.1 \Omega$ .  
Calculate the current in the motor. 4
- (c) The batteries take 10 hours to fully recharge using a constant charging current of 3.2 A.  
Calculate how much charge is transferred to the batteries in this time. 3
29. A laser used in laser eye surgery procedures produces 250 pulses of light per second. Each light pulse transfers 60 mJ of energy.  
Calculate the average power produced by each pulse of light. 4

30. A student designs the circuit shown to act as a high temperature warning circuit.

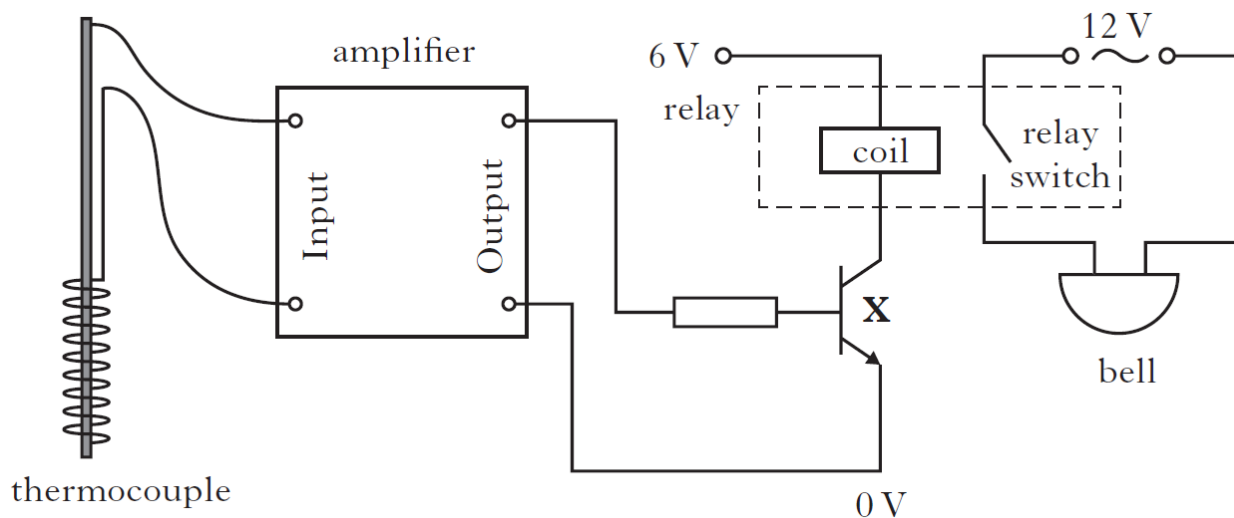

- (a) Name component X. 1
- (b) Explain how the circuit operates to sound the bell when the temperature of the thermocouple reaches a certain value. 3
- (c) The student also plays an electric guitar. The guitar is connected to a different amplifier and two loudspeakers as shown.

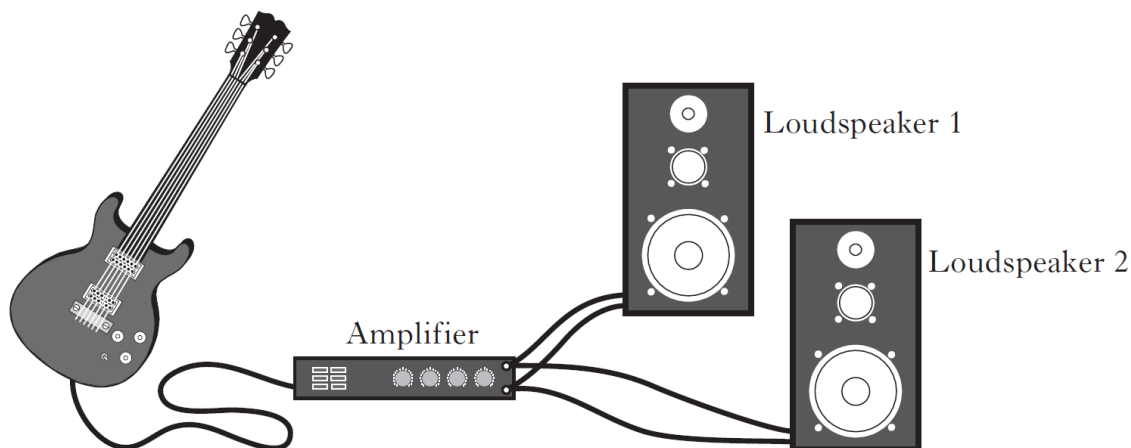

Each loudspeaker has a resistance of  $16 \Omega$ .

Calculate the combined resistance of the two loudspeakers when connected as shown.

3

31. An experimental geothermal power plant uses heat energy from deep underground to produce electrical energy. A pump forces water at high pressure down a pipe. The water is heated and returns to the surface. At this high pressure the boiling point of water is  $180\text{ }^{\circ}\text{C}$ .

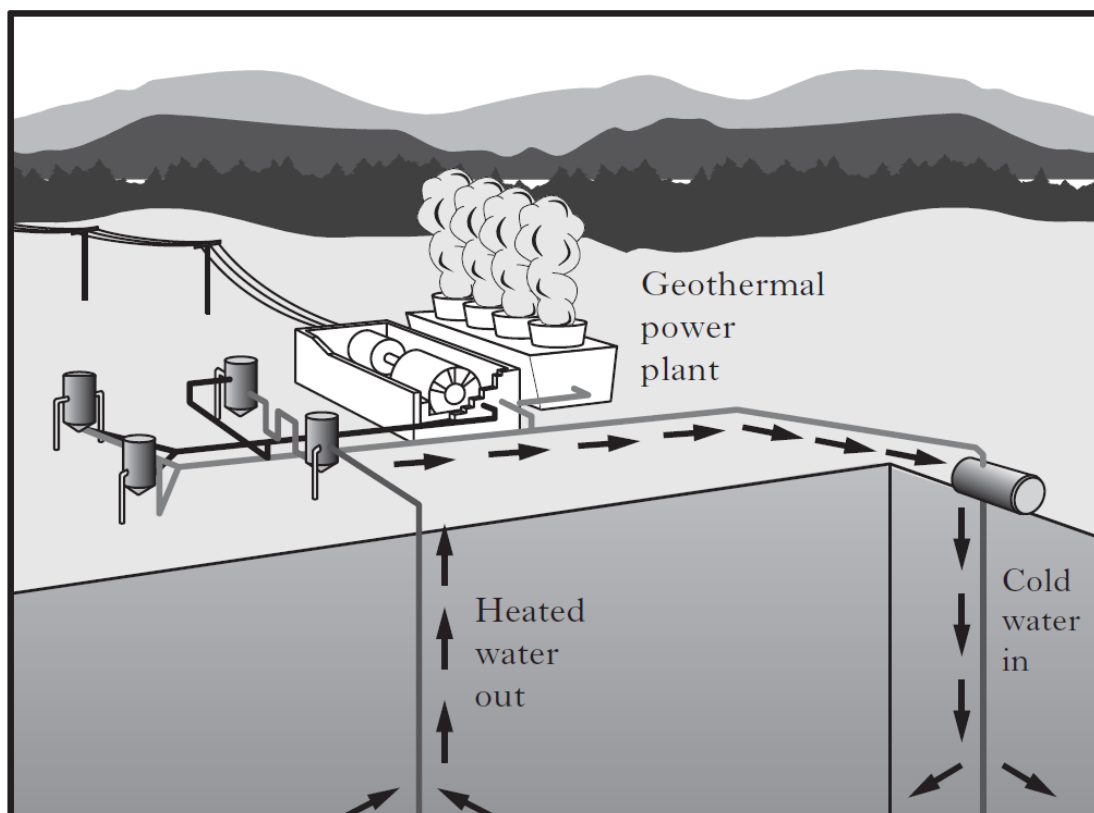

The plant is designed to pump  $82\text{ kg}$  of heated water, to the surface, each second. The specific heat capacity of this water is  $4320\text{ J kg}^{-1}\text{ }^{\circ}\text{C}^{-1}$ .

- (a) The water enters the ground at  $20\text{ }^{\circ}\text{C}$  and emerges at  $145\text{ }^{\circ}\text{C}$ .  
Calculate the heat energy absorbed by the water each second. 3
- (b) The hot water is fed into a heat exchanger where  $60\%$  of this heat energy is used to vapourise another liquid into gas. This gas is used to drive a turbine which generates electrical energy.  
The specific latent heat of vapourisation for this liquid is  $3.42 \times 10^5\text{ J kg}^{-1}$ .  
Calculate the mass of this liquid which is vapourised each second. 4

32. An overhead projector contains a lamp and a motor that operates a cooling fan. A technician has a choice of two lamps to fit in the projector.

**Lamp A:** rated  $24.0\text{ V}$ ,  $2.5\ \Omega$

**Lamp B:** rated  $24.0\text{ V}$ ,  $5.4\ \Omega$



- (a) Which lamp gives a brighter light when operating at the correct voltage?  
Explain your answer. 2
- (b) Calculate the power developed by lamp A when it is operating normally. 3
- (c) The overhead projector plug contains a fuse.  
Draw the circuit symbol for a fuse. 1
- (d) The technician builds a test circuit containing a resistor and a motor, as shown in **Circuit 1**.

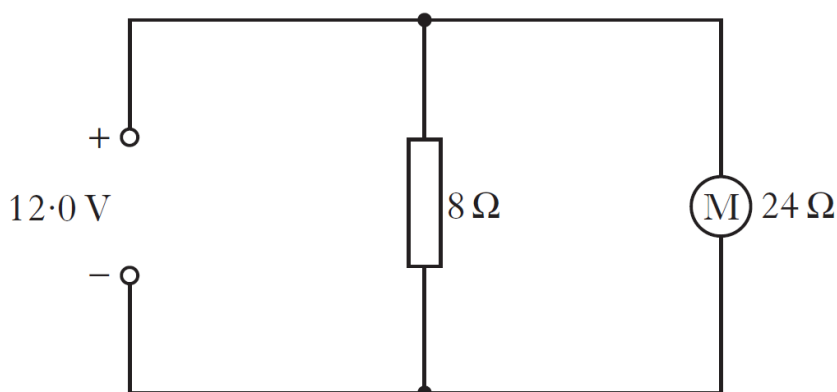

**Circuit 1**

- (i) State the voltage across the motor. 1
- (ii) Calculate the combined resistance of the resistor and the motor. 3

32. (continued)

(e) The resistor and the motor are now connected in series, as shown in **Circuit 2**.

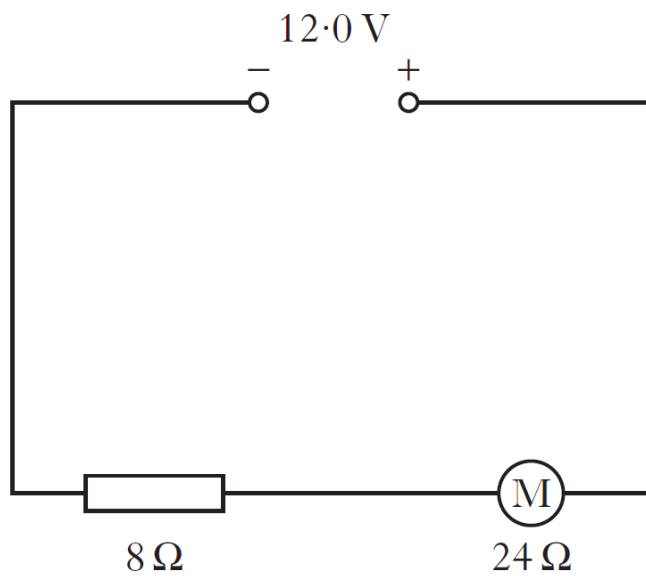

**Circuit 2**

State how this affects the speed of the motor compared to **Circuit 1**.

Explain your answer.

2



33. A photographic darkroom has a buzzer that sounds when the light level in the room is too high. The circuit diagram for the buzzer system is shown below.

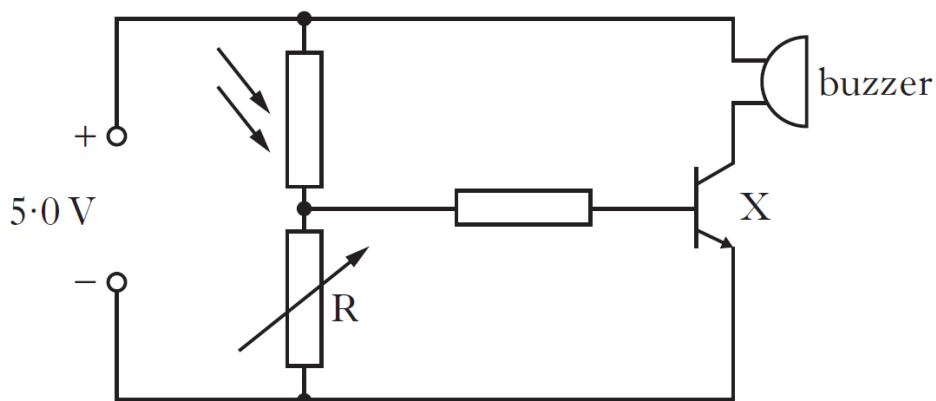

- (a) (i) Name component X. 1
- (ii) What is the purpose of component X in the circuit? 1
- (b) The darkroom door is opened and the light level increases. Explain how the circuit operates to sound the buzzer. 3
- (c) The table shows how the resistance of the LDR varies with light level.

<i>Light level (units)</i>	<i>LDR Resistance (<math>\Omega</math>)</i>
20	4500
50	3500
80	2500

The variable resistor has a resistance of 570  $\Omega$ .

The light level increases to 80 units.

Calculate the current in the LDR. 4

- (d) What is the purpose of the variable resistor R in this circuit? 1

34. A circuit with three gaps is shown below.

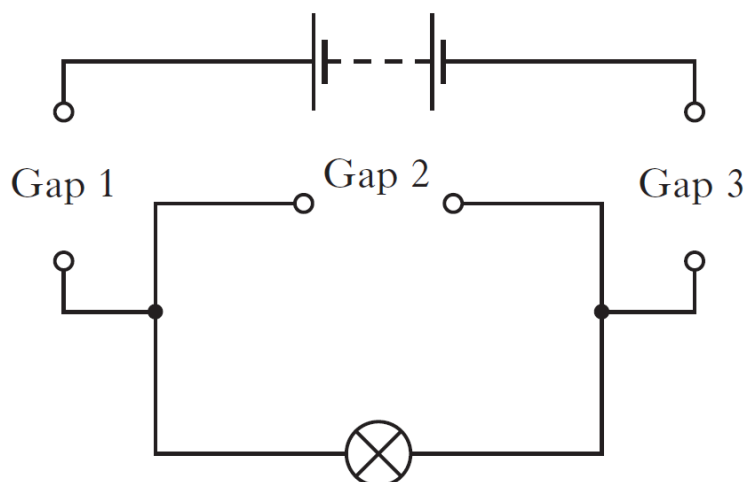

Which row in the table shows the combination of conductors and insulators that should be placed in the gaps to allow the lamp to light?

	<i>Gap 1</i>	<i>Gap 2</i>	<i>Gap 3</i>
A	conductor	insulator	conductor
B	conductor	conductor	insulator
C	conductor	conductor	conductor
D	insulator	insulator	conductor
E	insulator	insulator	insulator

35. In which circuit below would the meter readings allow the resistance of  $R_2$  to be calculated?

A

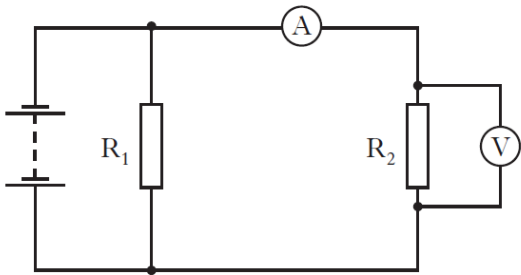

B

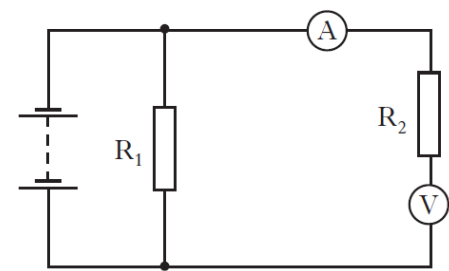

C

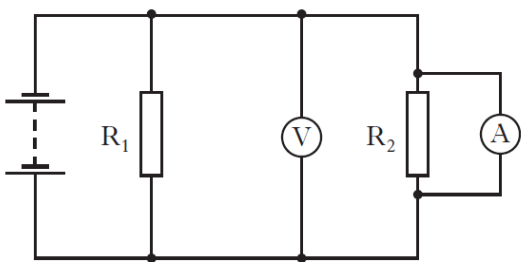

D

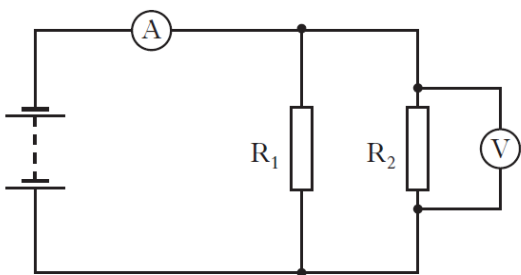

E

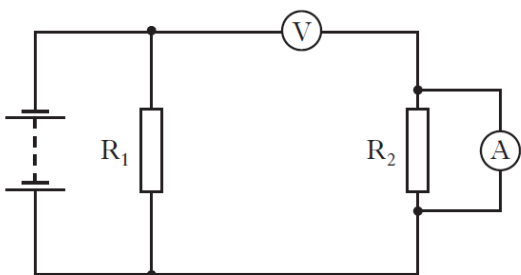

36. A circuit is set up as shown.

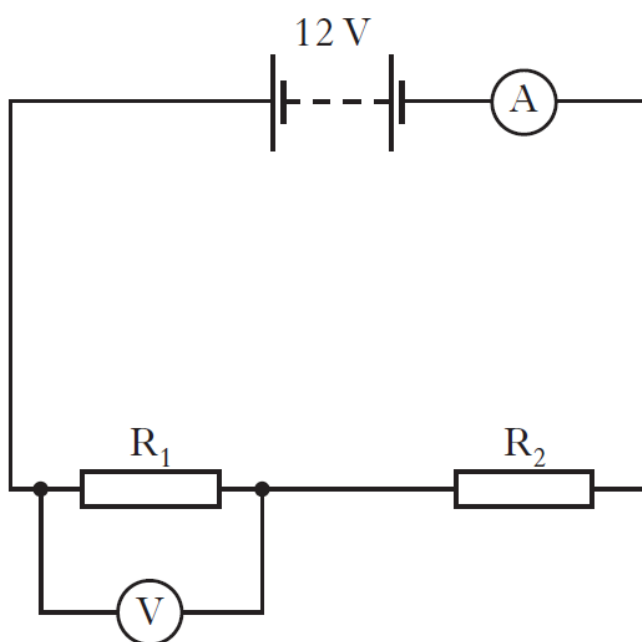

The reading on the ammeter is 3.0 A.

The reading on the voltmeter is 4.0 V.

Which row in the table shows the current in resistor  $R_2$  and the voltage across resistor  $R_2$ ?

	<i>Current in resistor <math>R_2</math> (A)</i>	<i>Voltage across resistor <math>R_2</math> (V)</i>
A	1.5	8.0
B	3.0	4.0
C	3.0	8.0
D	1.5	12.0
E	6.0	4.0

37. A circuit is set up as shown.

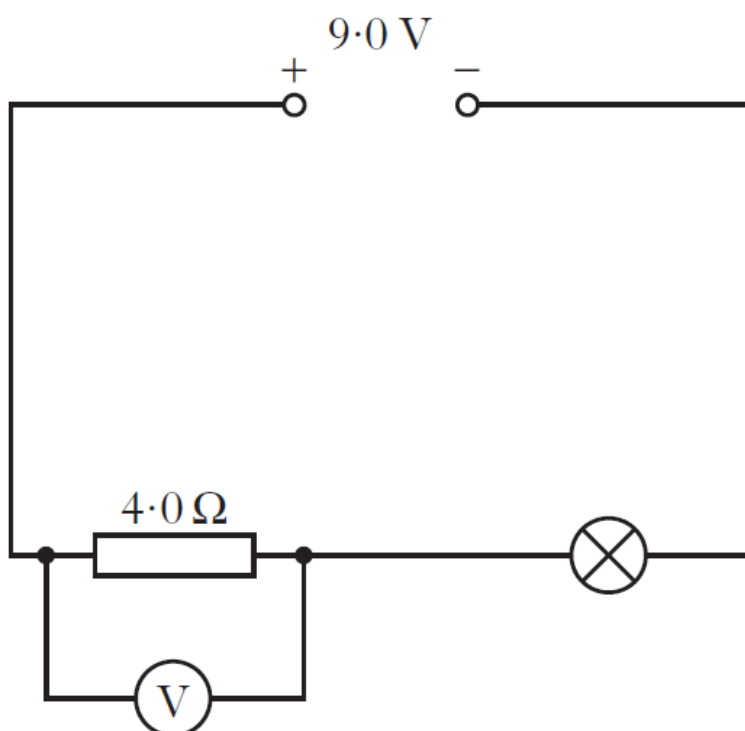

The current in the lamp is  $1.5\text{ A}$ .

The reading on the voltmeter is  $6.0\text{ V}$ .

The power developed in the lamp is

- A  $3.0\text{ W}$
  - B  $4.5\text{ W}$
  - C  $6.0\text{ W}$
  - D  $9.0\text{ W}$
  - E  $13.5\text{ W}$ .
38. Which of the following devices converts heat energy into electrical energy?
- A Solar cell
  - B Resistor
  - C Thermocouple
  - D Thermistor
  - E Transistor

39. The pressure of a gas in a sealed syringe is  $1.5 \times 10^5 \text{ Pa}$ .

The temperature of the gas is  $27^\circ\text{C}$ .

The temperature of the gas is now raised by  $10^\circ\text{C}$  and the volume of the gas halved.

The new pressure of the gas in the syringe is

- A  $1.1 \times 10^5 \text{ Pa}$   
B  $2.8 \times 10^5 \text{ Pa}$   
C  $3.1 \times 10^5 \text{ Pa}$   
D  $4.1 \times 10^5 \text{ Pa}$   
E  $11 \times 10^5 \text{ Pa}$ .
40. A diver is measuring the pressure at different depths in the sea using a simple pressure gauge. Part of the pressure gauge consists of a cylinder containing gas trapped by a moveable piston.

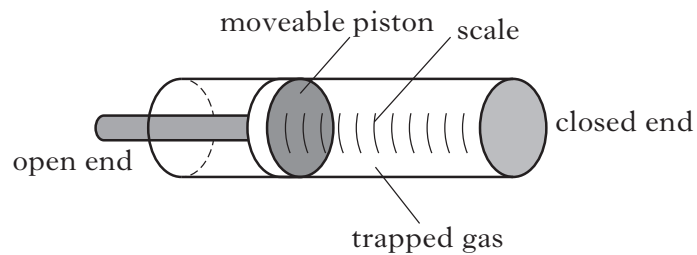

At sea level, the atmospheric pressure is  $1.01 \times 10^5 \text{ Pa}$  and the trapped gas exerts a force of  $262 \text{ N}$  on the piston.

- (a) Calculate the area of the piston.

41. Which of the following graphs shows the relationship between the pressure  $P$  and the volume  $V$  of a fixed mass of gas at constant temperature?

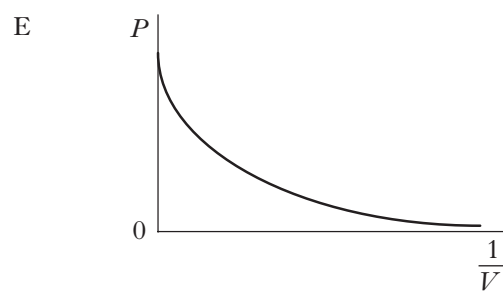
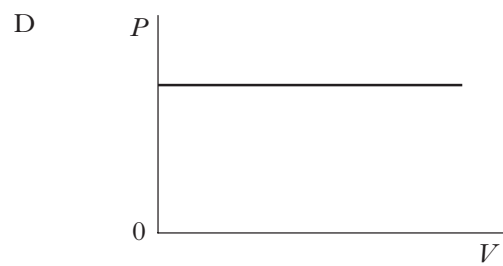
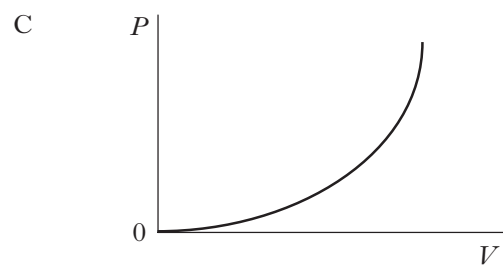
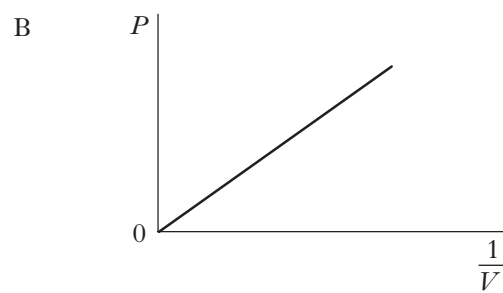
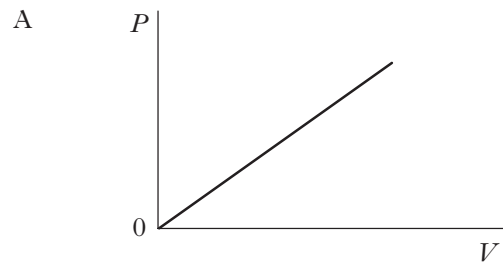

42. An aircraft cruises at an altitude at which the external air pressure is  $0.40 \times 10^5$  Pa. The air pressure inside the aircraft cabin is maintained at  $1.0 \times 10^5$  Pa. The area of an external cabin door is  $2.0 \text{ m}^2$ .

What is the outward force on the door due to the pressure difference?

- A  $0.30 \times 10^5$  N
- B  $0.70 \times 10^5$  N
- C  $1.2 \times 10^5$  N
- D  $2.0 \times 10^5$  N
- E  $2.8 \times 10^5$  N

43. A fixed mass of gas is heated inside a rigid container. As its temperature changes from  $T_1$  to  $T_2$  the pressure increases from  $1.0 \times 10^5$  Pa to  $2.0 \times 10^5$  Pa.

Which row in the table shows possible values for  $T_1$  and  $T_2$ ?

	$T_1$	$T_2$
A	$27^\circ\text{C}$	$327^\circ\text{C}$
B	$30^\circ\text{C}$	$60^\circ\text{C}$
C	$80^\circ\text{C}$	$40^\circ\text{C}$
D	303 K	333 K
E	600 K	300 K

44. Ice at a temperature of  $-10^\circ\text{C}$  is heated until it becomes water at  $80^\circ\text{C}$ .

The temperature change in kelvin is

- A 70 K
- B 90 K
- C 343 K
- D 363 K
- E 636 K.



45. A garden spray consists of a tank, a pump and a spray nozzle.

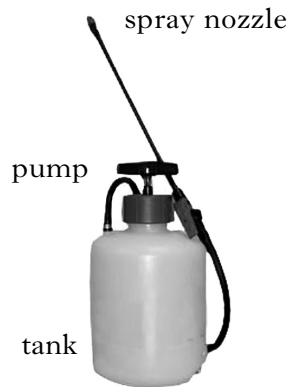

The tank is partially filled with water.

The pump is then used to increase the pressure of the air above the water.

- (a) The volume of the compressed air in the tank is  $1.60 \times 10^{-3} \text{ m}^3$ .

The surface area of the water is  $3.00 \times 10^{-2} \text{ m}^2$ .

The pressure of the air in the tank is  $4.60 \times 10^5 \text{ Pa}$ .

- (i) Calculate the force on the surface of the water. 3

- (ii) The spray nozzle is operated and water is pushed out until the pressure of the air in the tank is  $1.00 \times 10^5 \text{ Pa}$ .

Calculate the volume of water expelled. 3

46. A student is training to become a diver.

(a) The student carries out an experiment to investigate the relationship between the pressure and volume of a fixed mass of gas using the apparatus shown.

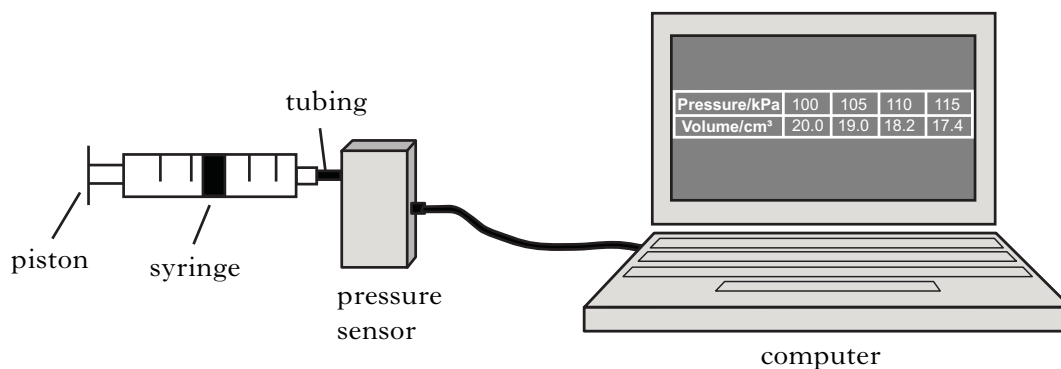

The pressure of the gas is recorded using a pressure sensor connected to a computer. The volume of the gas is also recorded. The student pushes the piston to alter the volume and a series of readings is taken.

The temperature of the gas is constant during the experiment.

The results are shown.

<i>Pressure/kPa</i>	100	105	110	115
<i>Volume/cm<sup>3</sup></i>	20.0	19.0	18.2	17.4

Use the kinetic model to explain the change in pressure as the volume of gas decreases.

47. A student carries out an experiment to investigate the relationship between the pressure and temperature of a fixed mass of gas. The apparatus used is shown.

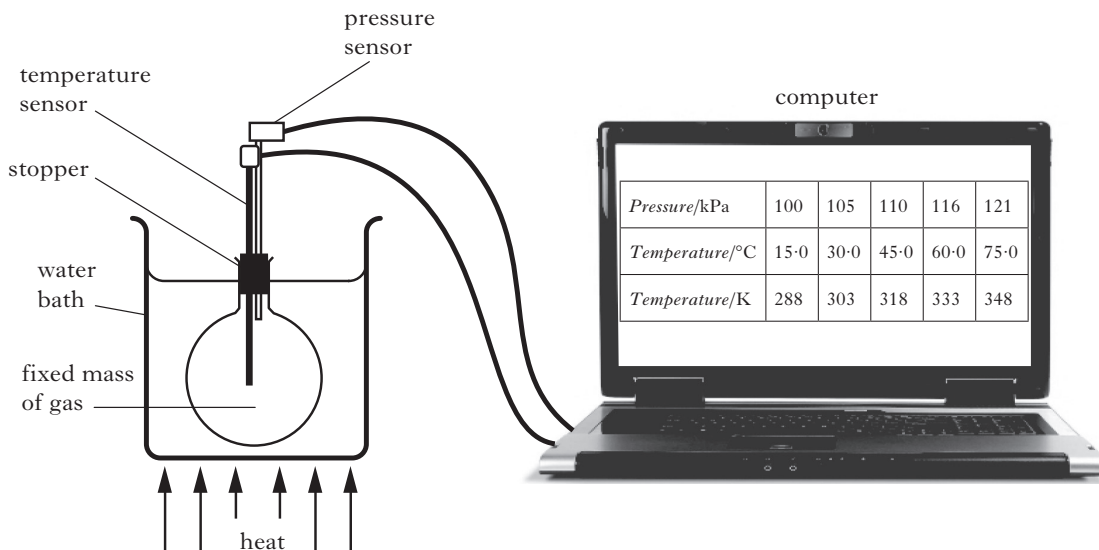

The pressure and temperature of the gas are recorded using sensors connected to a computer. The gas is heated slowly in the water bath and a series of readings is taken.

The volume of the gas remains constant during the experiment.

The results are shown.

<i>Pressure/kPa</i>	100	105	110	116	121
<i>Temperature/°C</i>	15.0	30.0	45.0	60.0	75.0
<i>Temperature/K</i>	288	303	318	333	348

Use the kinetic model to explain the change in pressure as the temperature of the gas increases.

48. One pascal is equivalent to
- A 1 N m
  - B 1 N m<sup>2</sup>
  - C 1 N m<sup>3</sup>
  - D 1 N m<sup>-2</sup>
  - E 1 N m<sup>-3</sup>.

49. A rigid cylinder contains  $8.0 \times 10^{-2} \text{ m}^3$  of helium gas at a pressure of 750 kPa. Gas is released from the cylinder to fill party balloons.

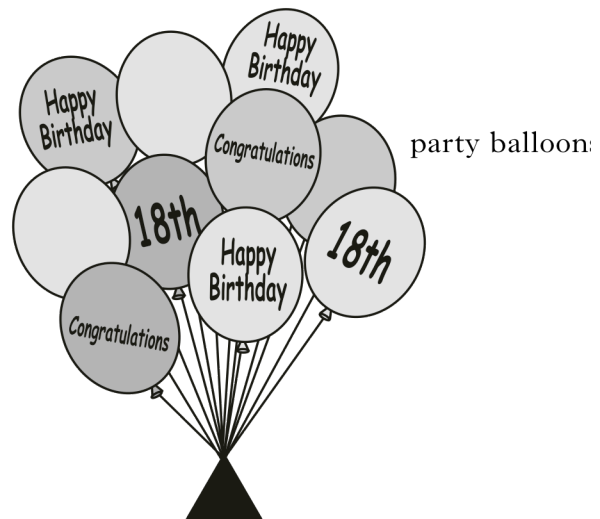
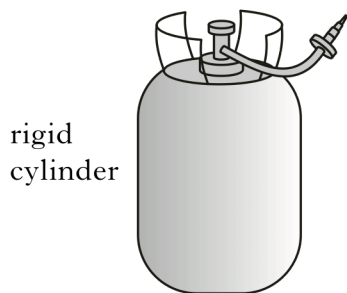

During the filling process, the temperature remains constant. When filled, each balloon holds  $0.020 \text{ m}^3$  of helium gas at a pressure of 125 kPa.

- (a) Calculate the total volume of the helium gas when it is at a pressure of 125 kPa. 3
- (b) Determine the maximum number of balloons which can be fully inflated by releasing gas from the cylinder. 3