

FOR OFFICIAL USE



National
Qualifications
2022 MODIFIED

Mark

X844/75/01

Applications of Mathematics Paper 1 (Non-calculator)

FRIDAY, 6 MAY

9:00 AM – 9:50 AM



* X 8 4 4 7 5 0 1 *

Fill in these boxes and read what is printed below.

Full name of centre

Town

Forename(s)

Surname

Number of seat

Date of birth

Day

Month

Year

Scottish candidate number

Total marks — 35

Attempt ALL questions.

You may NOT use a calculator.

To earn full marks you must show your working in your answers.

State the units for your answer where appropriate.

Write your answers clearly in the spaces provided in this booklet. Additional space for answers is provided at the end of this booklet. If you use this space you must clearly identify the question number you are attempting.

Use blue or black ink.

Before leaving the examination room you must give this booklet to the Invigilator; if you do not, you may lose all the marks for this paper.



* X 8 4 4 7 5 0 1 0 1 *

FORMULAE LIST

Circumference of a circle $C = \pi d$

Area of a circle $A = \pi r^2$

Theorem of Pythagoras

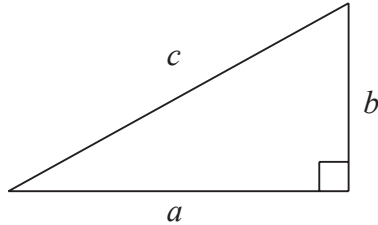

$$a^2 + b^2 = c^2$$

Volume of a cylinder $V = \pi r^2 h$

Volume of a prism $V = Ah$

Volume of a cone $V = \frac{1}{3} \pi r^2 h$

Volume of a sphere $V = \frac{4}{3} \pi r^3$

Standard deviation $s = \sqrt{\frac{\sum (x - \bar{x})^2}{n - 1}}$

or $s = \sqrt{\frac{\sum x^2 - \frac{(\sum x)^2}{n}}{n - 1}}$, where n is the sample size.

Gradient



$$\text{gradient} = \frac{\text{vertical height}}{\text{horizontal distance}}$$



Total marks — 35
 Attempt ALL questions

- Steven blew up the tyres on his bike.

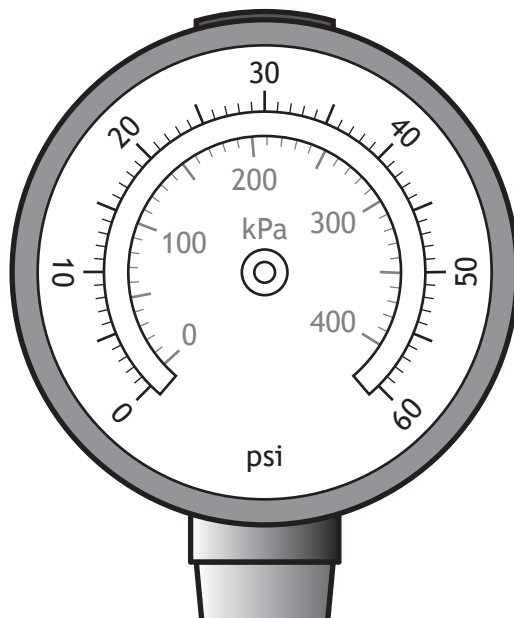

In order to be safe, his tyres should be blown up to a pressure of between 35 and 45 psi.

Steven blew his tyres up to a pressure of 230 kPa

Determine whether his tyres are at a safe pressure.

Justify your answer.

2

[Turn over



2. Marie and John are both reading the same book.
Marie is using an e-book reader and John is reading a hardback book.



John thinks he has read more of the book than Marie.

Is he correct?

Use your working to justify your answer.

2

3. The temperature, in degrees Celsius, of a restaurant fridge is recorded each day. The temperatures over a 13 day period were:

3.2 4.2 3.3 3.6 3.7 3.2 4.2
 3.3 3.4 3.6 3.2 4.1 2.9

(a) For this data, calculate:

- the median
- the lower quartile
- the upper quartile.

2

(b) Construct a box plot for this set of data.

2

(An additional grid, if required, can be found on *page 16*.)

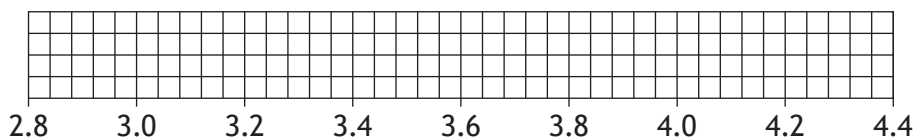

restaurant fridge temperatures (°C)

(c) Calculate the interquartile range for this set of data.

1

(d) The temperatures of a café fridge were also recorded for the same 13 day period.

The interquartile range of these temperatures was 0.9 degrees Celsius.

Make one valid comment comparing the temperatures of these two fridges.

1

[Turn over



4. Kieran and Dylan decide to redesign their garden.
There are several tasks that need to be done in order to achieve this.

Activity	Description	Preceding task	Time taken
A	lay patio	I	5 hours
B	assemble furniture	A	1 hour 30 minutes
C	remove decking	none	6 hours
D	paint fence	G	3 hours
E	lay artificial grass	I	3 hours
F	remove grass	none	2 hours
G	buy all materials	C,F	45 minutes
H	plant patio tubs	A	2 hours 15 minutes
I	roughcast wall	D	1 hour 45 minutes

- (a) Complete the diagram to show the tasks and times in the boxes.
(An additional diagram, if required, can be found on *page 16*.)

2

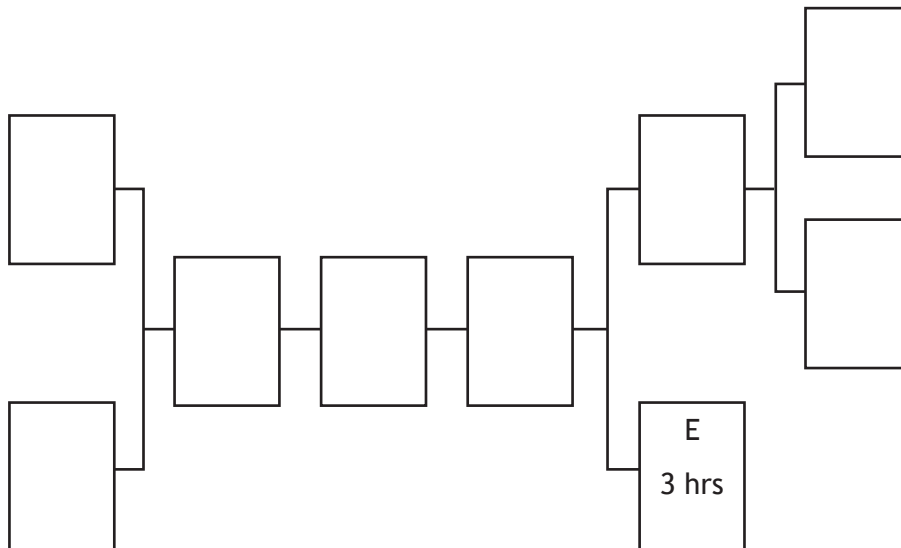

4. (continued)

- (b) Based on the times given, calculate the minimum time to complete all of the work.

Give your answer in hours and minutes.

2

[Turn over



5. Jade runs a game stall at the Christmas coffee morning.
 Her game requires two spinners to be spun and allowed to come to rest.
 The spinners are fair and are shown below.

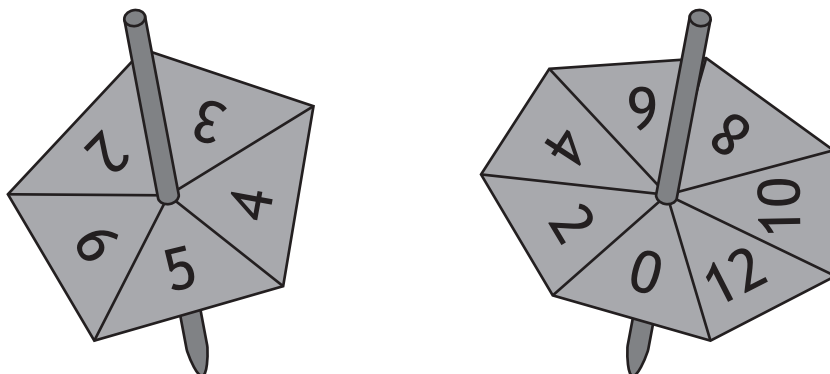

The numbers on which the spinners come to rest are multiplied together.
 To win a prize the answer to this multiplication must be **greater than 30**.
 Calculate the probability of winning a prize.

3

6. Farah works in a shop.
She earns £8.40 per hour.
She gets paid overtime at time-and-a-half.
In January she worked 100 hours basic plus 30 hours overtime.
In January she paid £33.50 in income tax, £61.92 in National Insurance and £25.20 towards her pension.
Calculate Farah's net pay for January.

2

[Turn over



* X 8 4 4 7 5 0 1 0 9 *

7. Tracy decides to walk to the top of Dumyat Hill from Blairlogie car park.

- The horizontal distance between these two places is 3 kilometres.
- Blairlogie car park is 21 metres above sea level.
- The top of Dumyat Hill is 420 metres above sea level.

Calculate the average gradient between the Blairlogie car park and the top of Dumyat Hill.

3

Give your answer as a fraction **in its simplest form**.



* X 8 4 4 7 5 0 1 1 0 *

8. Bryan, Jamie and Jessica bought two medium pizzas between them.

- Bryan ate $\frac{5}{7}$ of a pizza.
- Jamie ate $\frac{2}{3}$ of a pizza.
- Jessica ate the rest.

Calculate the total amount of pizza that Jessica ate.

3

Give your answer as a fraction of a pizza.

[Turn over



* X 8 4 4 7 5 0 1 1 1 *

9. Zainab designs a new badge.
The design is based on a rectangle and a semi-circle as shown in the diagram.

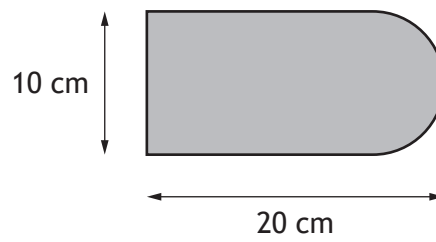

She decides to put gold edging around the badge.
Calculate the length of gold edging she needs.
Take $\pi = 3.14$

2



10. A youth group is planning a fundraising night to help pay for a trip.
The expenses for the night are shown.

DJ and disco	£340
Hall hire	£50
Hog roast	£770
Ticket production	£40

They will sell 200 tickets.

They need to make a profit of £2000.

Calculate the minimum ticket price to achieve this profit.

2

[Turn over



* X 8 4 4 7 5 0 1 1 3 *

11. A flag is in the shape of an isosceles triangle with a rectangle on the top.

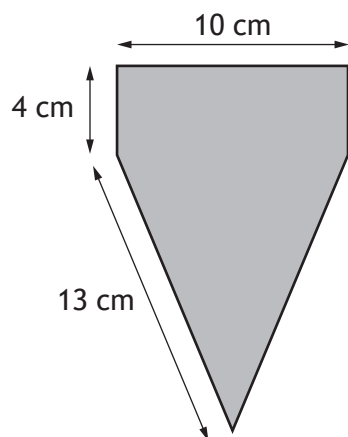

Calculate the area of the flag.

4



12. A company delivers parcels to people's homes.
The probability of a parcel arriving damaged is 0.023.
In one month, the company delivered 700 parcels, of which 15 were damaged.
Determine if this is more or less than expected.

2

[END OF QUESTION PAPER]



* X 8 4 4 7 5 0 1 1 5 *