

FOR OFFICIAL USE

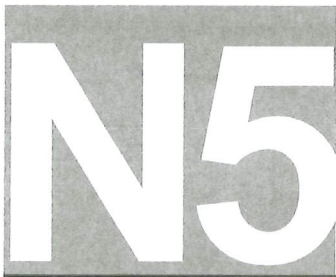

National
Qualifications
2024

--	--	--	--	--	--

Mark

--

X847/75/02

Mathematics
Paper 2

FRIDAY, 3 MAY

10:30 AM – 12:00 NOON



* X 8 4 7 7 5 0 2 *

Fill in these boxes and read what is printed below.

Full name of centre

Town

WORKED SOLUTIONS

--

Forename(s)

Surname

Number of seat

--

H

--

Date of birth

Day

Month

Year

Scottish candidate number

--	--

--	--

--	--

--	--	--	--	--	--	--	--	--	--

Total marks — 50

Attempt ALL questions.

You may use a calculator.

To earn full marks you must show your working in your answers.

State the units for your answer where appropriate.

Write your answers clearly in the spaces provided in this booklet. Additional space for answers is provided at the end of this booklet. If you use this space you must clearly identify the question number you are attempting.

Use blue or black ink.

Before leaving the examination room you must give this booklet to the Invigilator; if you do not, you may lose all the marks for this paper.



* X 8 4 7 7 5 0 2 0 1 *

FORMULAE LIST

The roots of $ax^2 + bx + c = 0$ are $x = \frac{-b \pm \sqrt{(b^2 - 4ac)}}{2a}$

Sine rule $\frac{a}{\sin A} = \frac{b}{\sin B} = \frac{c}{\sin C}$

Cosine rule $a^2 = b^2 + c^2 - 2bc \cos A$ or $\cos A = \frac{b^2 + c^2 - a^2}{2bc}$

Area of a triangle $A = \frac{1}{2}ab \sin C$

Volume of a sphere $V = \frac{4}{3}\pi r^3$

Volume of a cone $V = \frac{1}{3}\pi r^2 h$

Volume of a pyramid $V = \frac{1}{3}Ah$

Standard deviation $s = \sqrt{\frac{\Sigma(x - \bar{x})^2}{n - 1}}$

or $s = \sqrt{\frac{\Sigma x^2 - \frac{(\Sigma x)^2}{n}}{n - 1}}$, where n is the sample size.



* X 8 4 7 7 5 0 2 0 2 *

Total marks — 50
Attempt ALL questions

1. Dougie pays £460 for a new laptop.
It is expected that the value of the laptop will depreciate by 26% each year.
Calculate the expected value of Dougie's laptop after 3 years.

3

$$100\% - 26\% = 74\% = 0.74$$

$$£460 \times 0.74^3 = 186.40304$$

$$\underline{\underline{\text{Expected value} = £186.40.}}$$

2. An ant colony occupies an area of 250 hectares.
There is an average of 1.22×10^6 ants per hectare.
Calculate the number of ants in the colony.
Give your answer in scientific notation.

2

$$1.22 \times 10^6 \times 250$$

$$305,000,000$$

$$\underline{\underline{3.05 \times 10^8 \text{ ants.}}}$$

[Turn over



3. In triangle ABC:

- AB = 25 metres
- AC = 18 metres
- BC = 34 metres.

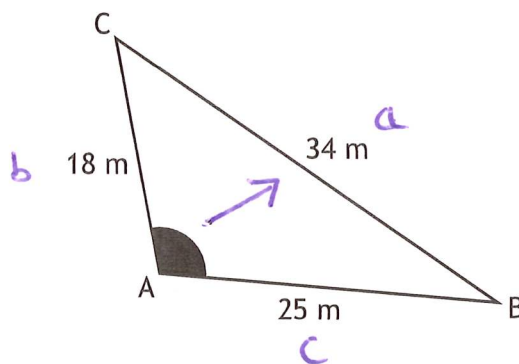

Calculate the size of the shaded angle at A.

3

$$\cos A = \frac{b^2 + c^2 - a^2}{2bc}$$

$$\cos A = \frac{18^2 + 25^2 - 34^2}{2(18)(25)}$$

$$\cos A = -0.23 \quad (\text{obtuse angle})$$

$$A = \cos^{-1}(-0.23)$$

$$\underline{\underline{\text{Angle} = 103.3^\circ}} \quad (1 \text{ dp})$$



4. Solve, algebraically, the inequation

$$\begin{aligned}
 5(x-2)+4 &< 7x+8. \\
 5x-10+4 &< 7x+8 \\
 5x-6 &< 7x+8 \\
 -6 &< 2x+8 \\
 -14 &< 2x \\
 -7 &< x \\
 \hookrightarrow \underline{\underline{x > -7}}
 \end{aligned}$$

3

5. This year the cost of Charley's car insurance is £278.40.

This is an increase of 16% on last year's cost.

Calculate the cost of Charley's insurance last year.

3

$$\begin{aligned}
 100\% + 16\% &= 116\% \\
 116\% &= £278.40 \\
 1\% &= 278.40 \div 116 = 2.4 \\
 100\% &= 2.4 \times 100 = 240
 \end{aligned}$$

Insurance last year = £240.

[Turn over



6. (a) Factorise $y^2 - 6y$.

Highest Common Factor

$$\underline{\underline{y(y-6)}}$$

1

(b) Hence simplify $\frac{y^2 - 6y}{y^2 - 3y - 18}$.

2

Trinomial $y^2 - 3y - 18$
 $(y+3)(y-6)$

	$y + 3$
y	$y^2 + 3y$
-6	$-6y - 18$

$$\hookrightarrow \frac{y(y-6)}{(y+3)(y-6)}$$

$$= \underline{\underline{\frac{y}{y+3}}}$$



7. A paperweight is in the shape of a cuboid. It consists of a hemisphere of red glass surrounded by clear glass.

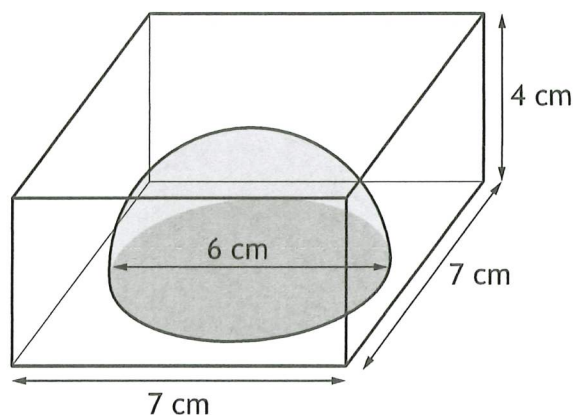

The cuboid has height 4 centimetres and a square base of length 7 centimetres.

The hemisphere has diameter 6 centimetres. \therefore radius = 3 cm

Calculate the volume of clear glass in the paperweight.

Give your answer correct to 2 significant figures.

4

Cuboid

$$\begin{aligned} V_{\text{cuboid}} &= l b h \\ &= 7 \times 7 \times 4 \\ &= 196 \text{ cm}^3 \end{aligned}$$

Hemi-sphere

$$\begin{aligned} V_{\text{sphere}} &= \frac{4}{3} \pi r^3 \\ V_{\text{hemisphere}} &= \frac{2}{3} \pi r^3 \\ &= \frac{2}{3} \times \pi \times 3^3 \\ &= 18\pi \\ &= 56.54866 \dots \text{ cm}^3 \end{aligned}$$

Clear Glass

$$\begin{aligned} \text{Volume} &= 196 - 56.54866 \dots \\ &= 139.45133 \dots \end{aligned}$$

Volume clear glass = 140 cm³ (2sf) [Turn over



$$ax^2 + bx + c = 0$$

8. Solve the equation $3x^2 + 8x + 1 = 0$.

Give your answers correct to 2 decimal places.

$$a=3 \quad b^2 - 4ac \quad x = \frac{-b \pm \sqrt{b^2 - 4ac}}{2a}$$

$$b=8 \quad (8)^2 - 4(3)(1)$$

$$c=1 \quad 64 - 12 \\ = 52$$

$$x = \frac{-8 \pm \sqrt{52}}{2(3)}$$

$$x = \frac{-8 - \sqrt{52}}{6} \quad \text{and} \quad x = \frac{-8 + \sqrt{52}}{6}$$

$$x = -2.53518\dots \quad x = -0.13148\dots$$

Solutions: $x = -2.54, -0.13$ (2dp)

9. Change the subject of the formula $f = \frac{2d+3}{e}$ to d .

$$\frac{2d+3}{e} = f$$

$$2d+3 = ef$$

$$2d = ef - 3$$

$$d = \frac{ef - 3}{2}$$

MARKS
DO NOT
WRITE IN
THIS
MARGIN

3

3



* X 8 4 7 7 5 0 2 0 8 *

10. Karen buys a door-number sign for her house.
The sign consists of parts of two identical circles.



AB is a chord to both circles.

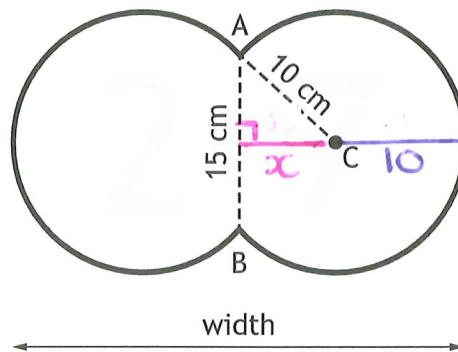

- AB has length 15 centimetres.
- The radius AC has length 10 centimetres.

Calculate the width of the sign.

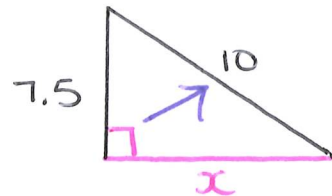

4

$$\begin{aligned} \text{width} &= 2(x + r) \\ &= 2(6.6 + 10) \\ &= 2(16.6) \end{aligned}$$

$$\underline{\underline{\text{width} = 33.2 \text{ cm}}}$$

$$x^2 = 10^2 - 7.5^2$$

$$x^2 = 43.75$$

$$x = \sqrt{43.75}$$

$$x = 6.614378\dots$$

$$x = 6.6 \text{ cm (1dp)}$$

[Turn over



11. Solve the equation $17 \sin x^\circ + 1 = 9$, for $0 \leq x < 360$.

3

$$17 \sin x + 1 = 9$$

$$17 \sin x = 8$$

$$\sin x = \frac{8}{17}$$

$$r_a = \sin^{-1}\left(\frac{8}{17}\right) = 28.1^\circ \text{ (1dp)}$$

$$x = 28.1, 180 - 28.1$$

$$\underline{\underline{x = 28.1^\circ, 151.9^\circ}}$$

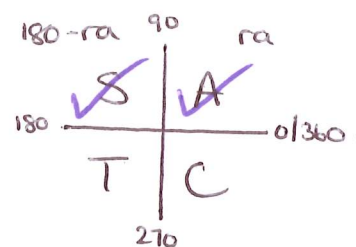
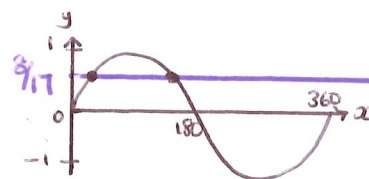

12. Express

$$\frac{2}{x+5} + \frac{3}{x-4}, \quad x \neq -5, x \neq 4$$

as a single fraction in its simplest form.

3

$$\frac{2(x-4)}{(x+5)(x-4)} + \frac{3(x+5)}{(x+5)(x-4)}$$

$$\frac{2(x-4) + 3(x+5)}{(x+5)(x-4)}$$

$$\frac{2x - 8 + 3x + 15}{(x+5)(x-4)} = \underline{\underline{\frac{5x + 7}{(x+5)(x-4)}}}$$



13. In triangle ABC:

MARKS DO NOT WRITE IN THIS MARGIN

$$180 - (40 + 30) = 110^\circ$$

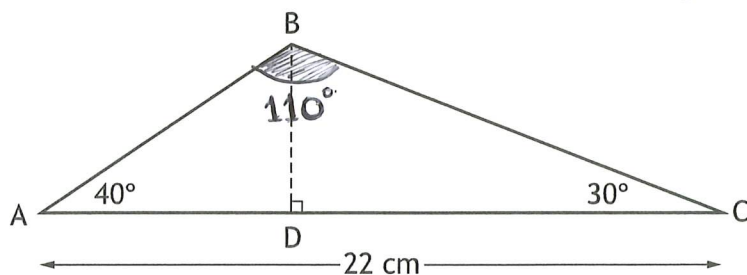

- AC = 22 centimetres
- angle BAC = 40°
- angle BCA = 30°
- BD is perpendicular to AC.

Find AB or BC first!

Calculate the length of BD.

5

$$\frac{AB}{\sin 30} = \frac{22}{\sin 110}$$

$$AB = \frac{22 \sin 30}{\sin 110}$$

$$AB = 11.7059555 \text{ cm}$$

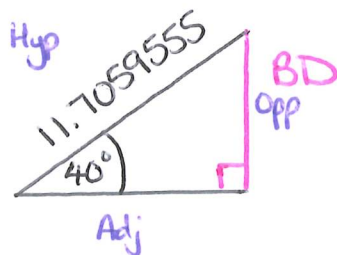

Sine Rule again or SOH CAH TOA.

$$\sin 40 = \frac{BD}{11.7059555}$$

$$BD = 11.7059555 \sin 40$$

$$= 7.524443 \dots$$

Height BD = 7.52 cm (2dp)

[Turn over



* X 8 4 7 7 5 0 2 1 1 *

14. The diagram shows a rhombus WXYZ with a diagonal ZX drawn.

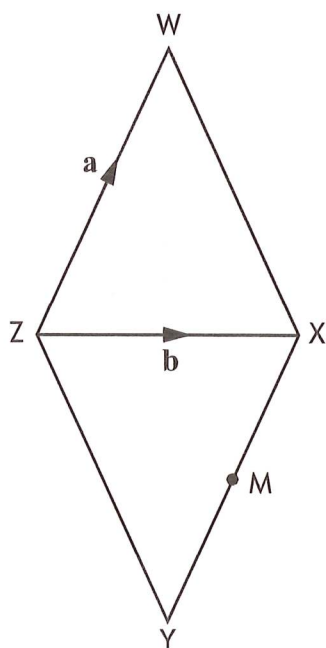

$$\vec{XY} = \vec{WZ} = -a$$

\vec{ZW} represents vector \mathbf{a} and \vec{ZX} represents vector \mathbf{b} .

- (a) Express \vec{WX} in terms of \mathbf{a} and \mathbf{b} .

1

$$\vec{WX} = -a + b$$

$$\vec{WX} = b - a$$

M is the mid-point of XY.

- (b) Express \vec{WM} in terms of \mathbf{a} and \mathbf{b} .

Give your answer in its simplest form.

2

$$\vec{WM} = \vec{WX} + \frac{1}{2}\vec{XY}$$

$$= b - a + \frac{1}{2}(-a)$$

$$= b - a - \frac{a}{2}$$

$$\vec{WM} = b - \frac{3}{2}a$$



15. The diagram shows a sector of a circle, centre C.

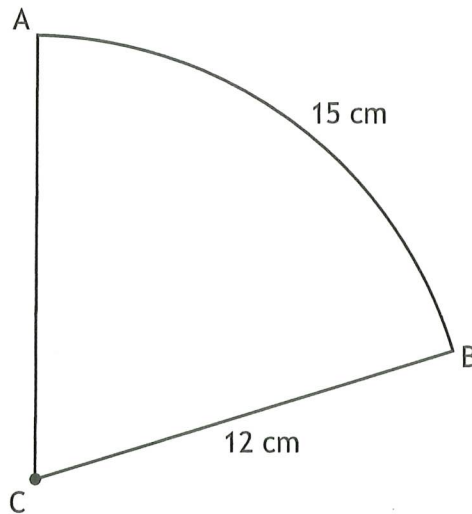

$r = 12$
 $D = 24$

The radius of the circle is 12 centimetres.
The length of arc AB is 15 centimetres.
Calculate the area of the sector.

3

$$\frac{\text{Angle}}{360} = \frac{\text{Arc}}{\pi D} = \frac{\text{Area}}{\pi r^2}$$

$$\frac{\text{Sector Area}}{\pi \times 12^2} = \frac{15}{\pi \times 24}$$

$$\text{Sector Area} = \frac{15 \times 144\pi}{24\pi}$$

$$\underline{\underline{\text{Sector Area} = 90\text{cm}^2}}$$

[Turn over



16. Express $3\cos^2 x^\circ - 1$ in the form $a + b\sin^2 x^\circ$.

Show your working.

2

Trig Identity $\sin^2 x + \cos^2 x = 1$
 $\therefore \cos^2 x = 1 - \sin^2 x$

$$\begin{aligned} & 3\cos^2 x - 1 \\ &= 3(1 - \sin^2 x) - 1 \\ &= 3 - 3\sin^2 x - 1 \\ &= \underline{\underline{2 - 3\sin^2 x}} \end{aligned}$$

where $a = 2$
 $b = -3$.
in $a + b\sin^2 x$.

[END OF QUESTION PAPER]



* X 8 4 7 7 5 0 2 1 4 *