

FOR OFFICIAL USE



National Qualifications

Mark

X847/75/02

Mathematics Paper 2

Duration — 1 hour 50 minutes



Fill in these boxes and read what is printed below.

Full name of centre

Town

Forename(s)

Surname

Number of seat

Date of birth

Day

Month

Year

Scottish candidate number

Total marks — 60

Attempt ALL questions.

You may use a calculator.

To earn full marks you must show your working in your answers.

State the units for your answer where appropriate.

Write your answers clearly in the spaces provided in this booklet. Additional space for answers is provided at the end of this booklet. If you use this space you must clearly identify the question number you are attempting.

Use blue or black ink.

Before leaving the examination room you must give this booklet to the Invigilator; if you do not, you may lose all the marks for this paper.



FORMULAE LIST

The roots of $ax^2 + bx + c = 0$ are $x = \frac{-b \pm \sqrt{(b^2 - 4ac)}}{2a}$

Sine rule $\frac{a}{\sin A} = \frac{b}{\sin B} = \frac{c}{\sin C}$

Cosine rule $a^2 = b^2 + c^2 - 2bc \cos A$ or $\cos A = \frac{b^2 + c^2 - a^2}{2bc}$

Area of a triangle $A = \frac{1}{2}ab \sin C$

Volume of a sphere $V = \frac{4}{3}\pi r^3$

Volume of a cone $V = \frac{1}{3}\pi r^2 h$

Volume of a pyramid $V = \frac{1}{3}Ah$

Standard deviation $s = \sqrt{\frac{\Sigma(x - \bar{x})^2}{n - 1}}$

or $s = \sqrt{\frac{\Sigma x^2 - \frac{(\Sigma x)^2}{n}}{n - 1}}$, where n is the sample size.



* X 8 4 7 7 5 0 2 0 2 *

Total marks — 60
Attempt ALL questions

1. A housing development is being built.

The price of a house built in 2020 is £250 000.

This price is expected to increase by 4% each year.

Calculate the expected price of a house built in 2022.

3

2. Light travels at 3×10^8 metres per second.

A star is 4.2×10^{17} metres away from Earth.

Calculate the number of seconds it takes for light from this star to reach Earth.

Give your answer in scientific notation.

2



* X 8 4 7 7 5 0 2 0 3 *

MARKS

DO NOT
WRITE IN
THIS
MARGIN

3. Factorise fully $3a^2 - 75$.

2

4. In triangle PQR

- $PR = 11.3$ metres
- $QR = 9.8$ metres
- angle $QPR = 54^\circ$.

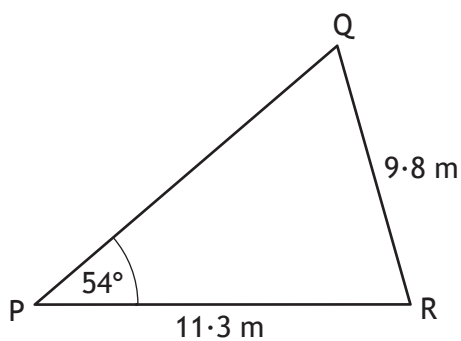

Calculate the size of acute angle PQR.

3



5. The vectors \mathbf{u} and \mathbf{v} are shown in the diagram below.

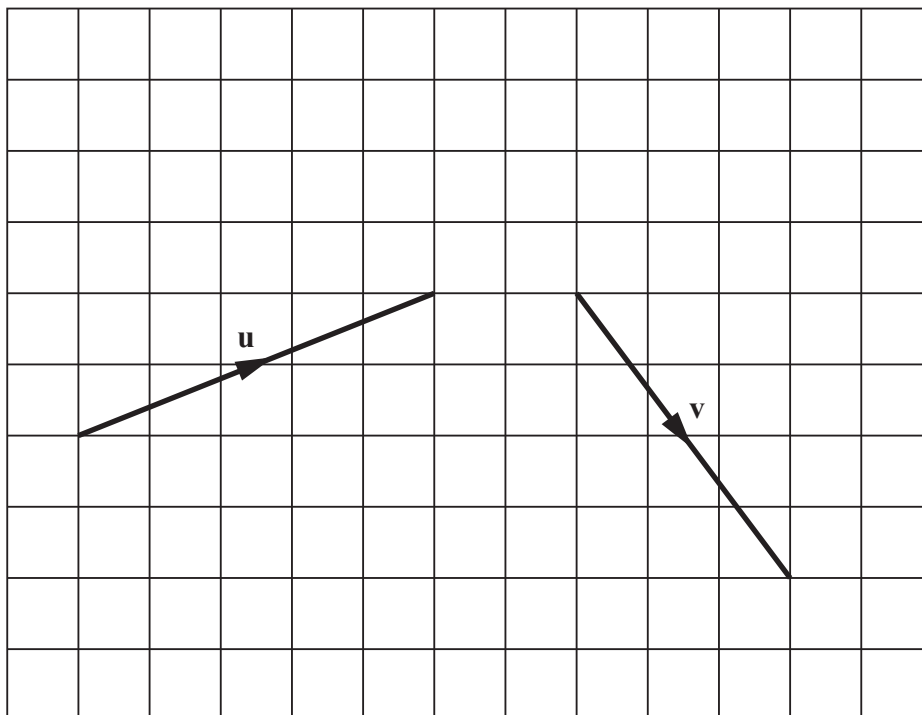

Find the resultant vector $\mathbf{u} - \mathbf{v}$.

Express your answer in component form.

2



* X 8 4 7 7 5 0 2 0 5 *

6. A company operates a bus route from the city centre to the airport.
The number of passengers on six of its buses on a Monday was

32 27 34 29 31 33.

- (a) Calculate the mean and standard deviation of the number of passengers. 4

- (b) The mean number of passengers the following Saturday was 28 and the standard deviation was 3.2.

Make two valid comments comparing the number of passengers on each bus on Monday and Saturday.

2



7. A fishing boat and a yacht left a harbour at the point H.
The fishing boat travelled 3.4 kilometres on a bearing of 047° to the point F.
The yacht travelled 5.7 kilometres on a bearing of 115° to the point Y.

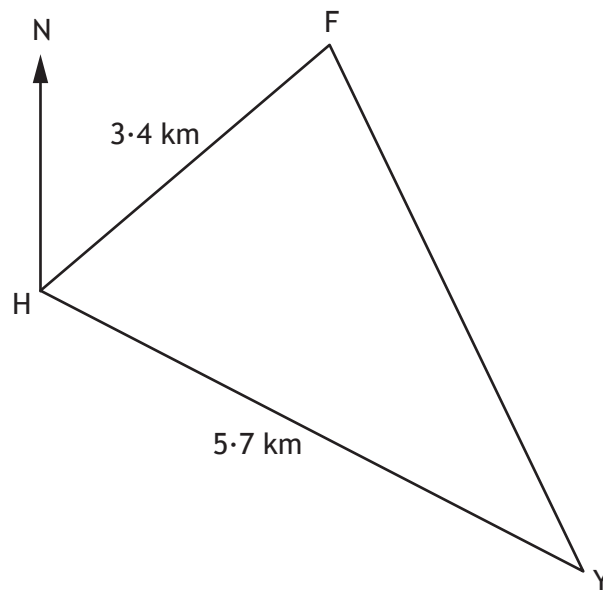

Calculate the distance between the fishing boat at F and the yacht at Y.

4



MARKS

DO NOT
WRITE IN
THIS
MARGIN

8. The diagram shows a sector of a circle, with centre C and radius 14 centimetres.
Angle ACB is 110° .

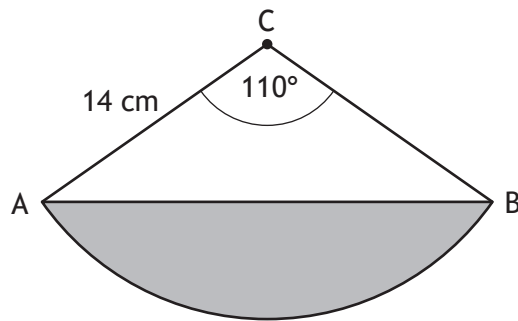

AB splits the sector into the shaded segment and triangle ABC.
Find the area of the shaded segment.

5



MARKS

DO NOT
WRITE IN
THIS
MARGIN

9. A straight line has equation $3x + 4y - 8 = 0$.

(a) Find the gradient of the line.

2

(b) State the coordinates of the point where the line crosses the y -axis.

1

10. Change the subject of the formula $d = \sqrt{\frac{3h}{2}}$ to h .

3



* X 8 4 7 7 5 0 2 0 9 *

11. The base of an ice cream cone has centre O and radius 4 centimetres.
The length of AB is 14.5 centimetres.

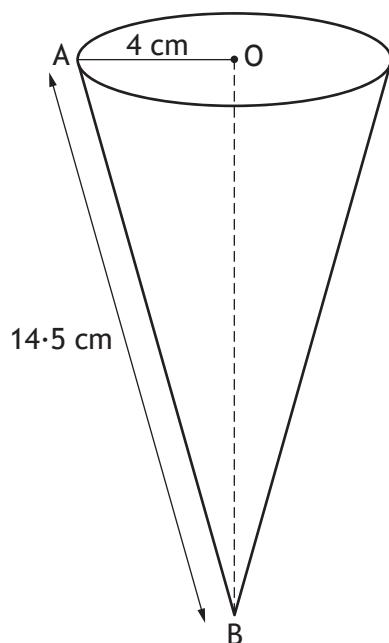

Calculate the volume of the cone.
Give your answer correct to 2 significant figures.

5



MARKS

DO NOT
WRITE IN
THIS
MARGIN

12. Express

$$\frac{6x}{y} \div \frac{2x^2}{y+5}, \quad x \neq 0, y \neq 0, y \neq -5$$

as a single fraction in its simplest form.

3



* X 8 4 7 7 5 0 2 1 1 *

13. The two photographs shown are mathematically similar.



The small photograph has an area of 80 square centimetres, and is 12 centimetres wide.

The large photograph has an area of 500 square centimetres.

Calculate the width of the large photograph.

3

14. The diagram shows the part of the blade of a circular saw above a workbench.

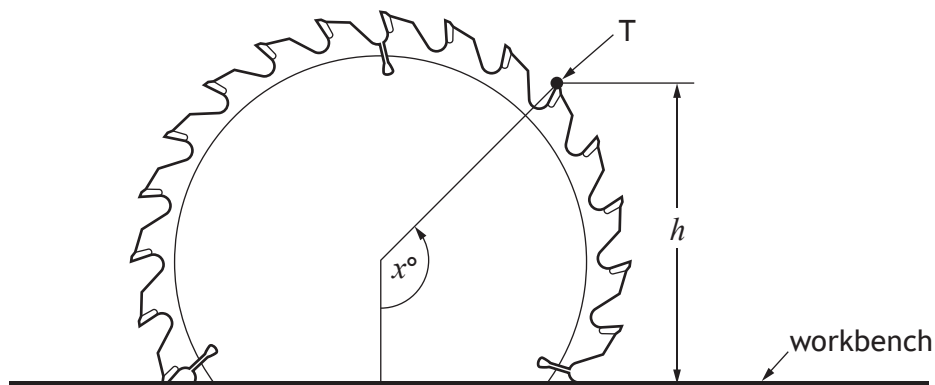

As the blade rotates, the height, h millimetres, of point T above the workbench is given by

$$h = 57 - 85 \cos x^\circ$$

where x is the angle the blade has turned anti-clockwise from a starting position.

- (a) Calculate the value of x when point T is first at a height of 115 millimetres above the workbench.

3

- (b) Calculate the value of x when point T is next at this height.

1



* X 8 4 7 7 5 0 2 1 3 *

15. The diagram shows a rectangle with breadth x centimetres.

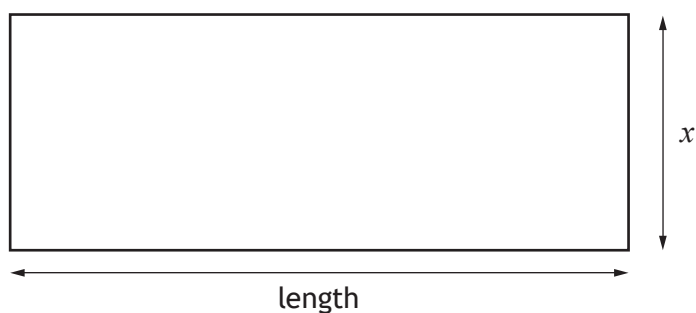

The length of the rectangle is 5 centimetres more than its breadth.

(a) Write down an expression for its length in terms of x .

1

The rectangle has an area of 20 square centimetres.

(b) Show that $x^2 + 5x - 20 = 0$.

2



MARKS

DO NOT
WRITE IN
THIS
MARGIN

15. (continued)

(c) Calculate x , the breadth of the rectangle.

Give your answer correct to one decimal place.

4



* X 8 4 7 7 5 0 2 1 5 *

MARKS

DO NOT
WRITE IN
THIS
MARGIN

16. Expand and simplify

$$\cos x^\circ (\tan x^\circ + 1).$$

Show your working.

2



* X 8 4 7 7 5 0 2 1 6 *

17. The triangle ABC is shown below

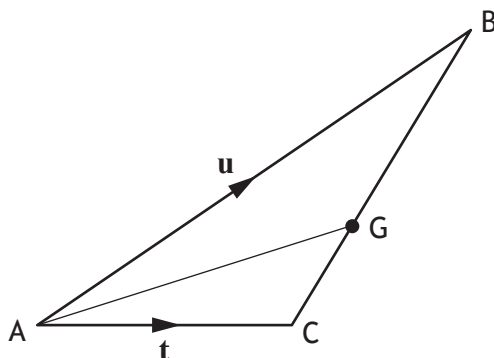

$$\vec{AB} = \mathbf{u} \text{ and } \vec{AC} = \mathbf{t}.$$

G is the point such that $CG = \frac{1}{3}CB$.

Express \vec{AG} in terms of \mathbf{u} and \mathbf{t} .

Give your answer in simplest form.

3

[END OF QUESTION PAPER]

