

FOR OFFICIAL USE



National Qualifications

Mark

X847/75/01

# Mathematics Paper 1 (Non-calculator)

Duration — 1 hour 15 minutes



\* X 8 4 7 7 5 0 1 \*

Fill in these boxes and read what is printed below.

Full name of centre

Town

Forename(s)

Surname

Number of seat

Date of birth

Day

Month

Year

Scottish candidate number

Total marks – 50

Attempt ALL questions.

You must NOT use a calculator.

To earn full marks you must show your working in your answers.

State the units for your answer where appropriate.

Write your answers clearly in the spaces provided in this booklet. Additional space for answers is provided at the end of this booklet. If you use this space you must clearly identify the question number you are attempting.

Use blue or black ink.

Before leaving the examination room you must give this booklet to the Invigilator; if you do not, you may lose all the marks for this paper.



\* X 8 4 7 7 5 0 1 0 1 \*



## FORMULAE LIST

The roots of  $ax^2 + bx + c = 0$  are  $x = \frac{-b \pm \sqrt{(b^2 - 4ac)}}{2a}$

Sine rule  $\frac{a}{\sin A} = \frac{b}{\sin B} = \frac{c}{\sin C}$

Cosine rule  $a^2 = b^2 + c^2 - 2bc \cos A$  or  $\cos A = \frac{b^2 + c^2 - a^2}{2bc}$

Area of a triangle  $A = \frac{1}{2}ab \sin C$

Volume of a sphere  $V = \frac{4}{3}\pi r^3$

Volume of a cone  $V = \frac{1}{3}\pi r^2 h$

Volume of a pyramid  $V = \frac{1}{3}Ah$

Standard deviation  $s = \sqrt{\frac{\Sigma(x - \bar{x})^2}{n - 1}}$

or  $s = \sqrt{\frac{\Sigma x^2 - \frac{(\Sigma x)^2}{n}}{n - 1}}$ , where  $n$  is the sample size.



\* X 8 4 7 7 5 0 1 0 2 \*

MARKS

DO NOT  
WRITE IN  
THIS  
MARGIN

Total marks — 50  
Attempt ALL questions

1. Calculate  $|\mathbf{d}|$ , the magnitude of vector  $\mathbf{d} = \begin{pmatrix} 1 \\ -4 \\ 8 \end{pmatrix}$ .

2

2. Evaluate  $5\frac{1}{2} - 1\frac{2}{7}$ .

2



3. Expand and simplify  $(6x - 5)(x + 3) + 2x(4 - x)$ .

3

4. In the diagram shown below

- PM is a tangent to the circle, centre O
- PN is a straight line
- angle OPM is  $14^\circ$ .

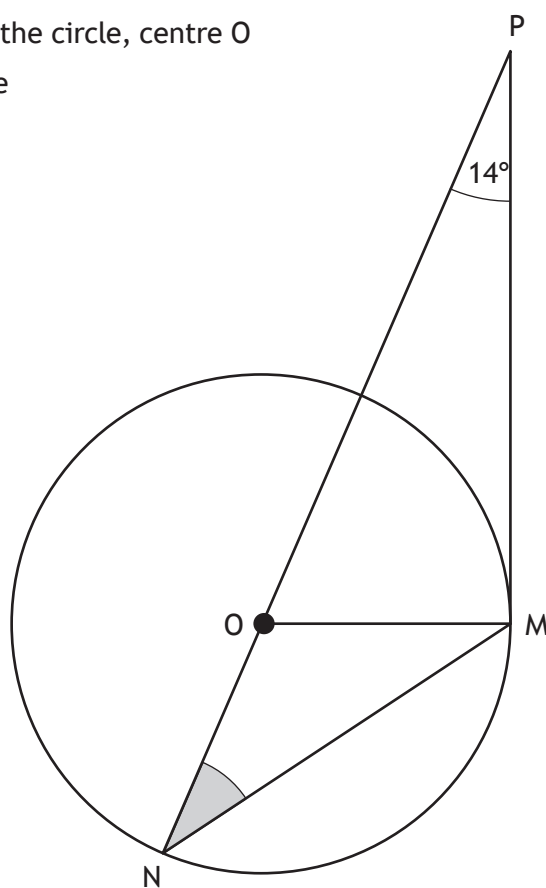

Calculate the size of shaded angle ONM.

2



5. The number of absentees at Applegrove High School was recorded each day over a four-week period.

The results are shown below.

7	8	8	11	12	14	14	15	17	17
18	20	20	21	23	24	25	26	27	29

Find the semi-interquartile range of this data.

2

6. The diagram below shows part of the graph of  $y = kx^2$ .

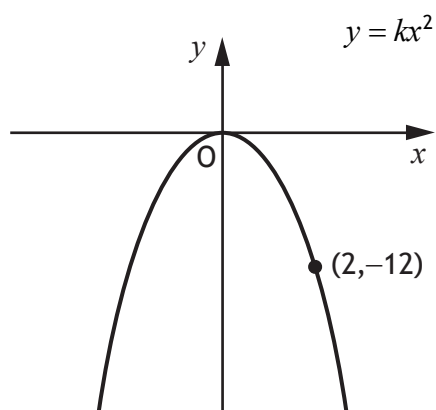

Find the value of  $k$ .

2



MARKS DO NOT  
WRITE IN  
THIS  
MARGIN

7. Solve, algebraically, the system of equations

$$5c + 2d = 4$$

$$4c - 3d = 17$$

3



\* X 8 4 7 7 5 0 1 0 6 \*

MARKS

DO NOT  
WRITE IN  
THIS  
MARGIN

8. Determine the nature of the roots of the function  $f(x) = x^2 + 4x - 7$ .

2

9. Express  $\sqrt{50} + \sqrt{45} - \sqrt{2}$  in its simplest form.

3



\* X 8 4 7 7 5 0 1 0 7 \*

10. David works in a shop, and is paid weekly.  
 His wage is made up of a basic wage plus commission on his sales.  
 The graph shows his wage,  $W$  pounds, against his sales,  $S$  pounds.

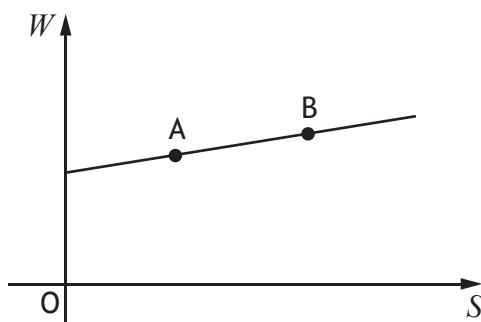

Point A represents sales of £6000 and a wage of £450.

Point B represents sales of £7200 and a wage of £510.

- (a) Find the equation of the line in terms of  $W$  and  $S$ .  
 Give the equation in its simplest form.

3



10. (continued)

(b) Calculate David's wage in a week when his sales are £1000.

1

11. Solve, algebraically, the inequation  $1 - (x + 4) > 2x$ .

3



12. A band sold 2400 tickets for their gig in Edinburgh.  
This was 75% of the number of tickets sold for their gig in Glasgow.  
Calculate the number of tickets sold for their gig in Glasgow.

3

13. The graph of  $y = a \cos x^\circ + b$ ,  $0 \leq x \leq 360$ , is shown.

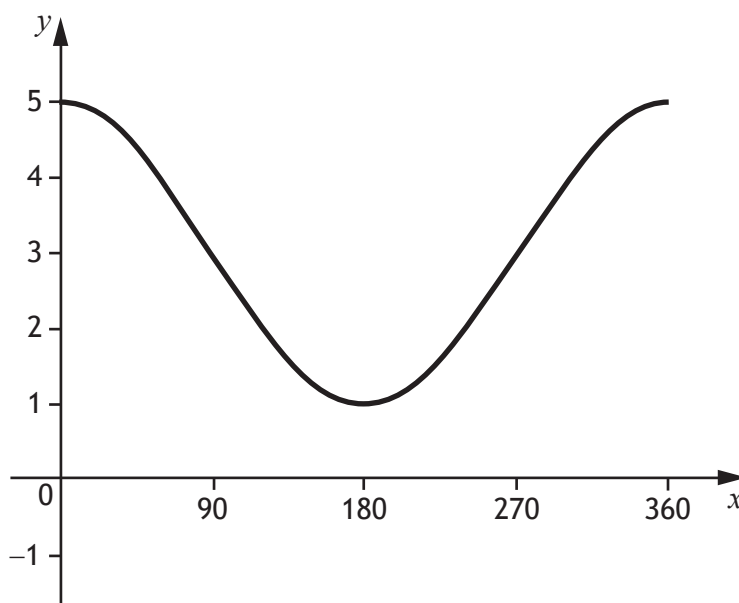

State the values of  $a$  and  $b$ .

2



14. The diagram shows a hemisphere relative to the coordinate axes.

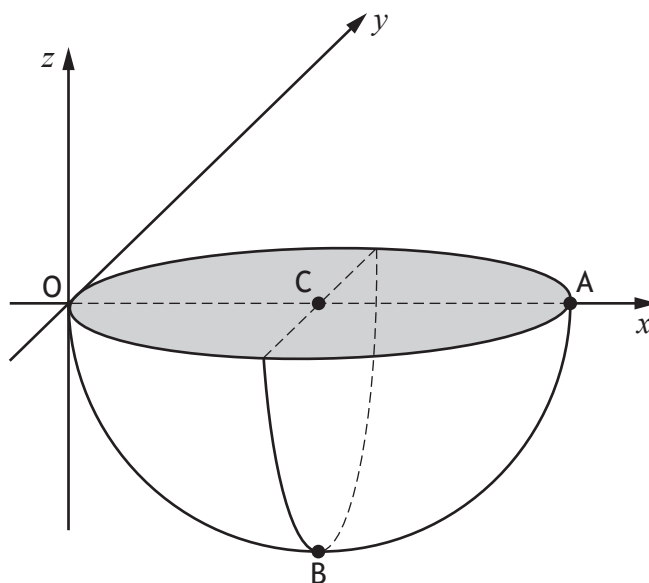

- A is the point  $(6, 0, 0)$
- C is the midpoint of diameter OA
- B is vertically below C

(a) State the coordinates of B.

1

(b) Calculate the volume of the hemisphere.

Give your answer in its simplest form in terms of  $\pi$ .

2



\* X 8 4 7 7 5 0 1 1 1 \*

MARKS

DO NOT  
WRITE IN  
THIS  
MARGIN

15. Evaluate  $16^{\frac{3}{2}}$ .

2

16. The function  $f(x)$  is defined by  $f(x) = 4 \sin 3x^\circ$ .  
Evaluate  $f(90)$ .

2



\* X 8 4 7 7 5 0 1 1 2 \*

MARKS

DO NOT  
WRITE IN  
THIS  
MARGIN

17. Sketch the graph of  $y = 2(x-1)^2 + 4$ .

On your sketch, show clearly the coordinates of the turning point and the point of intersection with the  $y$ -axis.

3



\* X 8 4 7 7 5 0 1 1 3 \*

18. The diagram below shows a design for a memory stick.  
The design consists of a rectangle, RSTU and part of a circle, centre C.

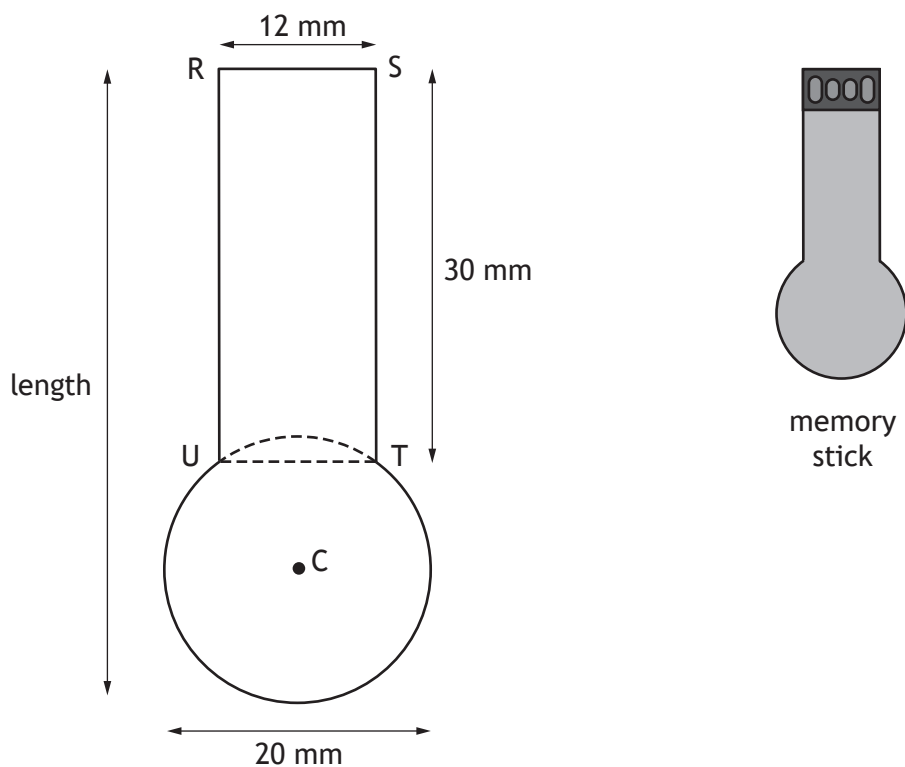

- $RS = UT = 12$  millimetres
- $RU = ST = 30$  millimetres
- The diameter of the circle is 20 millimetres
- $UT$  is a chord of the circle

Calculate the length of the memory stick.

4



MARKS

DO NOT  
WRITE IN  
THIS  
MARGIN

19. Solve the equation by factorising

$$6x^2 + 13x - 5 = 0$$

3

[END OF QUESTION PAPER]



\* X 8 4 7 7 5 0 1 1 5 \*