

1. The sketch below shows the final design for one piece of playground equipment, a bouncer.

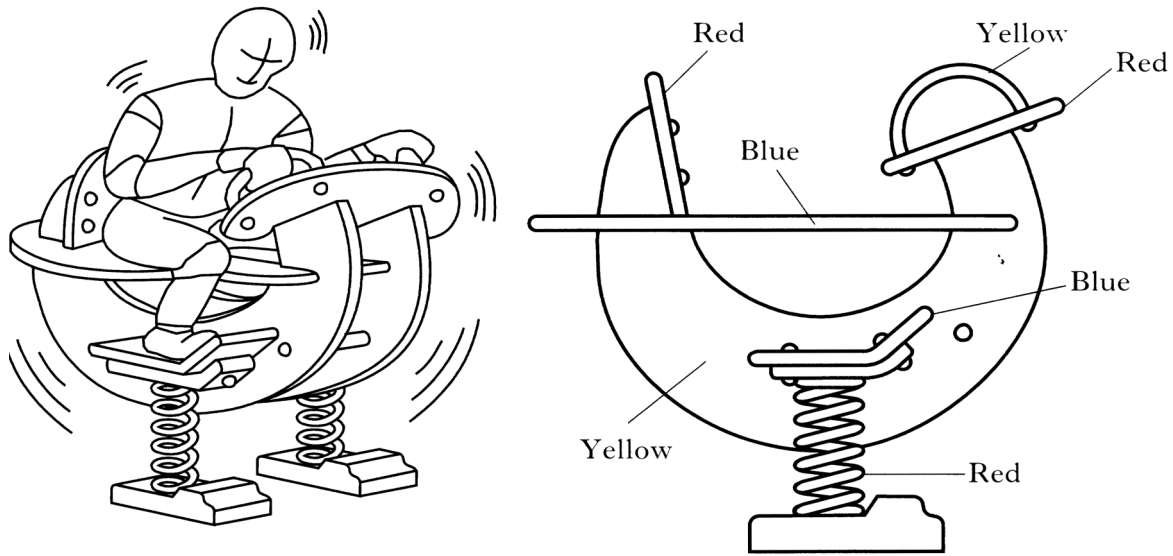

(b) Suggest one reason why the specification asked for primary colours to be used on this product.

---



---

1

(c) Unfortunately the coil springs will corrode if they are exposed to the weather. They are to be protected by **'plastic dip-coating'**. Suggest one further reason for choosing this process to give an appropriate finish.

---



---

1

(d) Describe the dip-coating process. Sketches may be used to illustrate your answer.

---



---



---



---



---



---

3

2. A base-stand had to be designed for a spherical 'eyeball' mirror. It was decided that a metal stand would be appropriate.

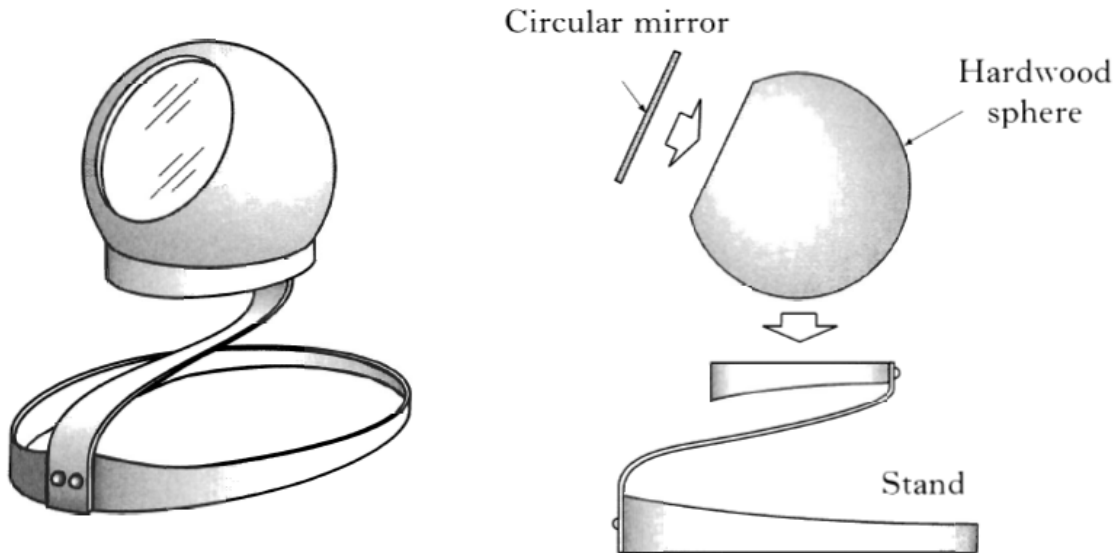

- (b) It was decided to use **flat head rivets** to join the stem to the hoops.

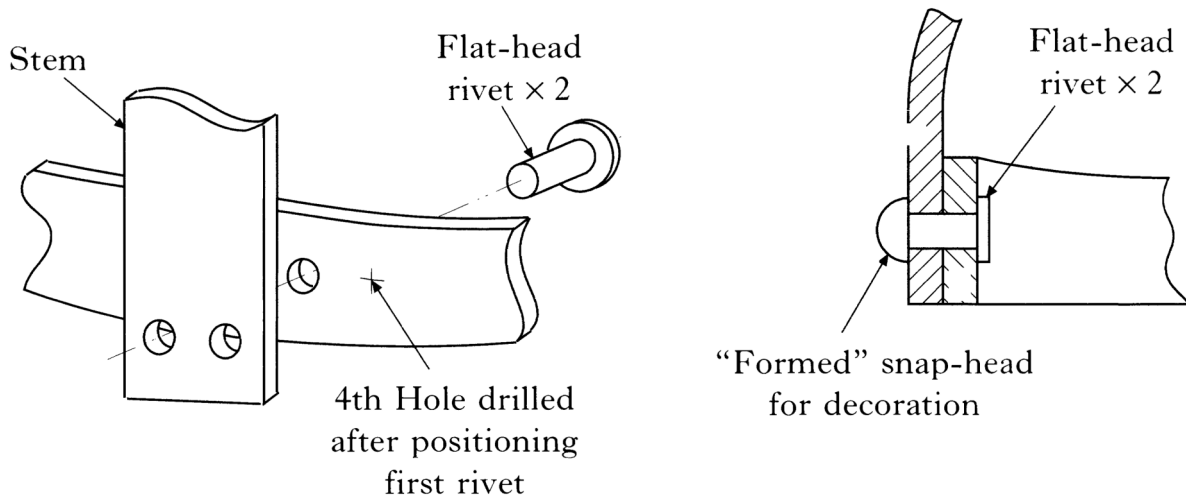

Name the tool used to **form** the snap-head of the rivet as illustrated above.

---

1

- (c) Three holes are shown in the sketch on the left. Explain why the **fourth** hole was not drilled.

---



---



---



---

1

3.

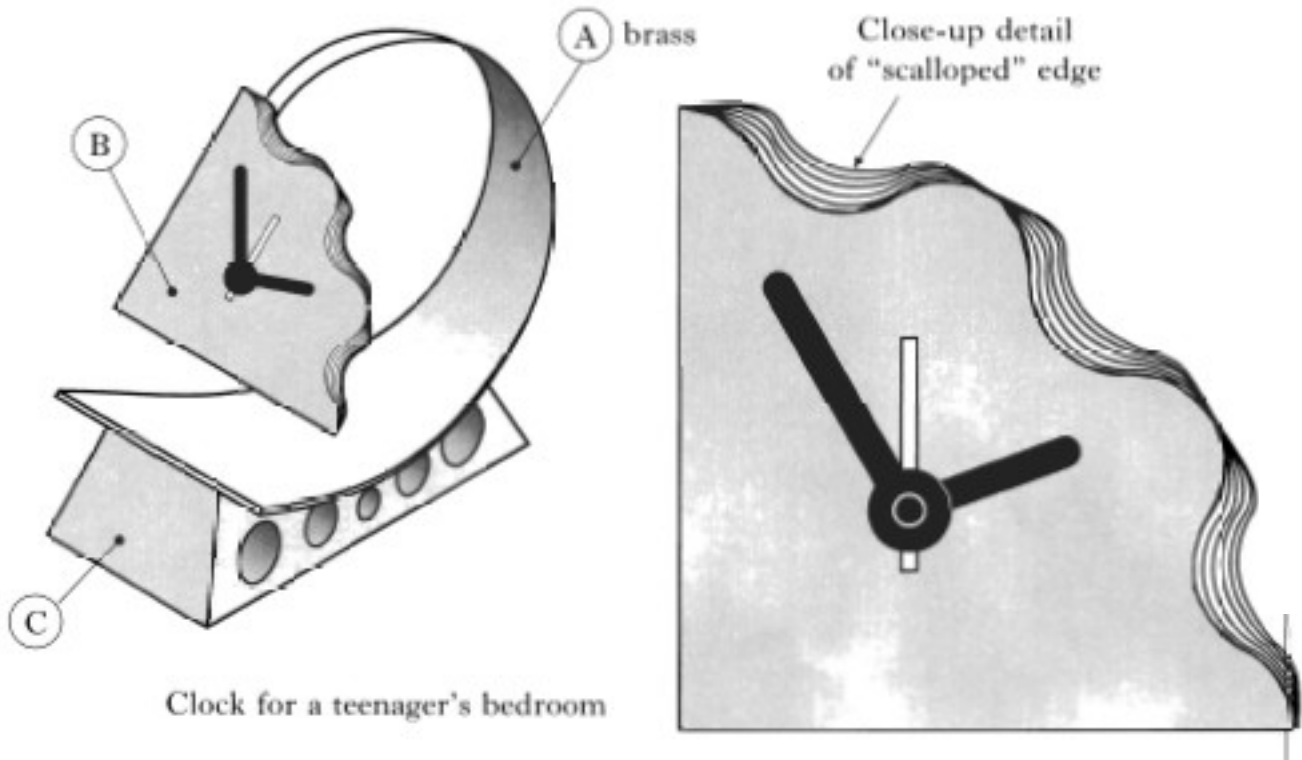

When forming part A, the brass sheet will become **work hardened**. In order to make it **malleable**, it will have to be **annealed**.

Explain these terms.

**Work hardened**

---

---

1

**Malleable**

---

---

1

**Annealed**

---

---

1

4. Brass is an alloy of **copper and zinc**.

(a) Name one other alloy.

---

1

(b) Explain why metals are alloyed.

---

---

1

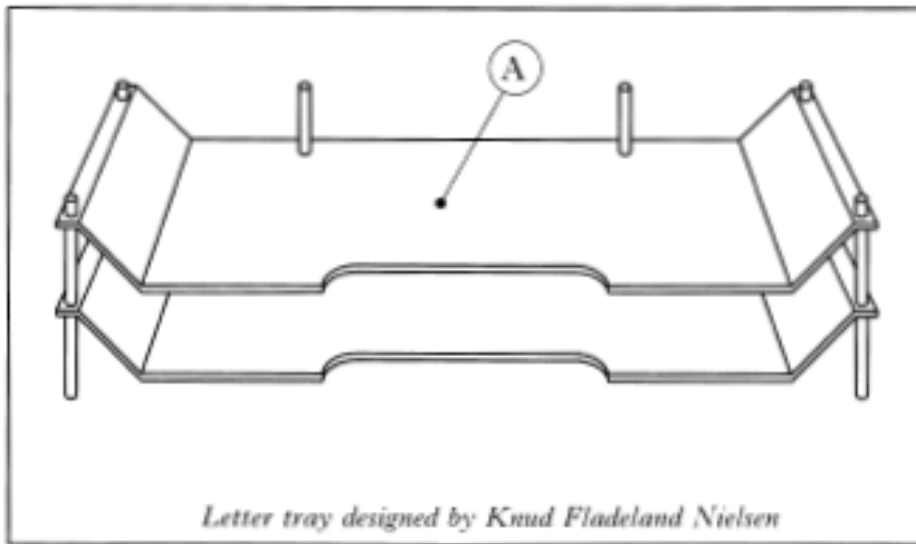

*Letter tray designed by Knud Fladeland Nielsen*

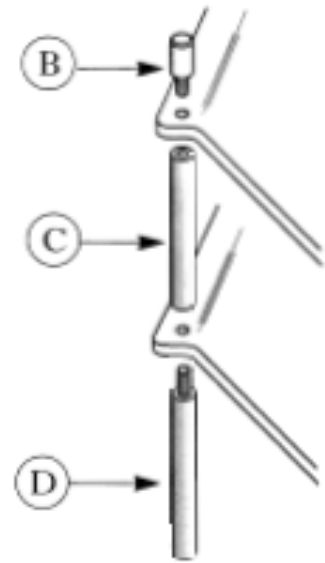

Construction details for leg components

1. The letter tray illustrated above is made from brass to and acrylic. It is intended for use in an office or at a workstation.

(a) The metal lathe will be used to turn the leg components B, C and D. Below is a sketch of component D.



(i) Name the type of chuck that will hold the metal in the lathe.

\_\_\_\_\_

(ii) Write down the sequence of operations required to produce Part D.

1. Face off both ends.

2. \_\_\_\_\_

3. \_\_\_\_\_

4. \_\_\_\_\_

(iii) Name the tool that should be used to accurately check the diameter of the part to be threaded is 6mm.

\_\_\_\_\_

1

3

1

(iv) What is the purpose of the chamfer on the end of the part to be threaded?

---

---

---

1

2. A table lamp is shown below.

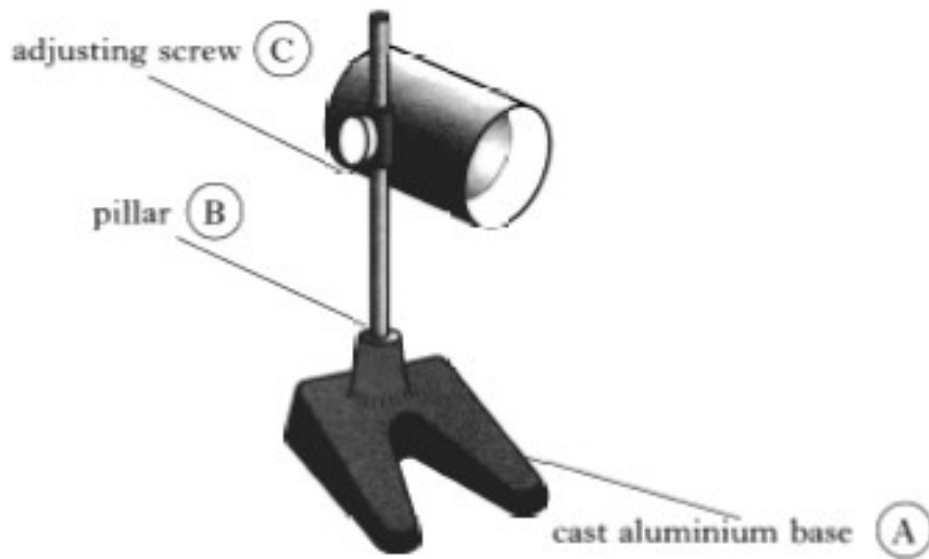

(a) State why aluminium is commonly used for casting in the school workshop.

---

---

1

(b) List three points which should be considered in the production of the pattern for the base.

1. 

---
2. 

---
3. 

---

3

(c) Write a short note on each of the following casting terms:

**Cope and Drag**

---

---

---

1

**Riser and Runner**

---

---

---

1

(d) The pillar is screwed into the aluminium base. Describe one procedure to ensure a high quality thread on the pillar.

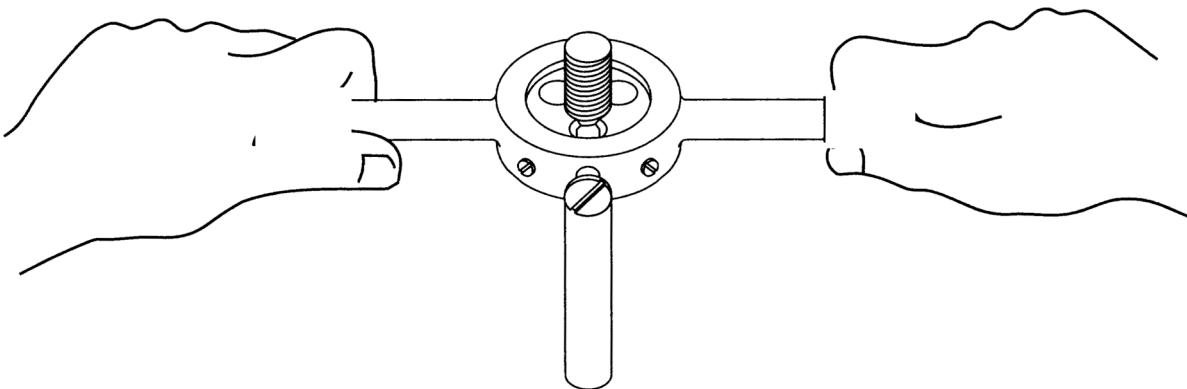

---

---

---

---

---

1

(e) State the name of the textured surface found on the adjusting screw.

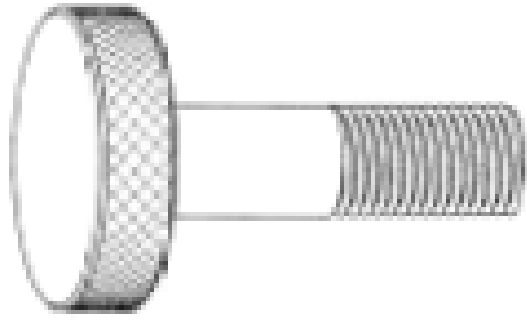

---

**1**

(f) State three reasons in general why a change in speed on the lathe may be necessary.

1. \_\_\_\_\_

\_\_\_\_\_

2. \_\_\_\_\_

\_\_\_\_\_

3. \_\_\_\_\_

\_\_\_\_\_

**3**

- 1. The screwdriver shown was made from a single piece of high carbon steel. The handle was coated using plastic powder.



- (a) Suggest two reasons for applying a plastic finish to the handle.

1. \_\_\_\_\_

\_\_\_\_\_

2

2. \_\_\_\_\_

\_\_\_\_\_

- (b) Describe how you could produce identically shaped handles on a number of screwdrivers.

\_\_\_\_\_

\_\_\_\_\_

\_\_\_\_\_

\_\_\_\_\_

1

- (c) The tip of the screwdriver was **hardened** and **tempered**. Describe how this is carried out.

\_\_\_\_\_

\_\_\_\_\_

\_\_\_\_\_

\_\_\_\_\_

\_\_\_\_\_

3



2. A brass coat hook which fits over the top of a door is shown below.

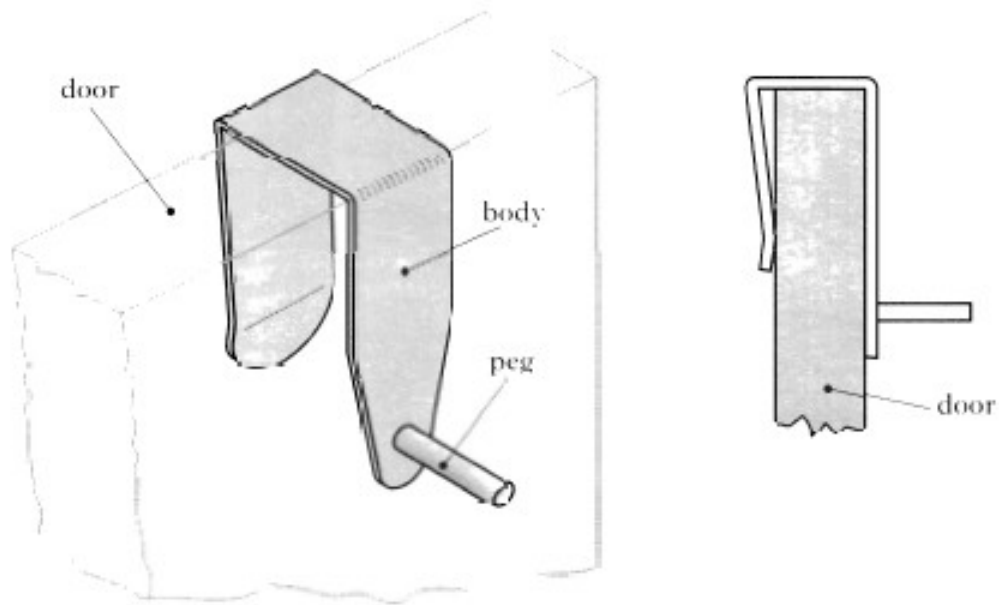

The body, made from 4mm brass plate is shown marked out.

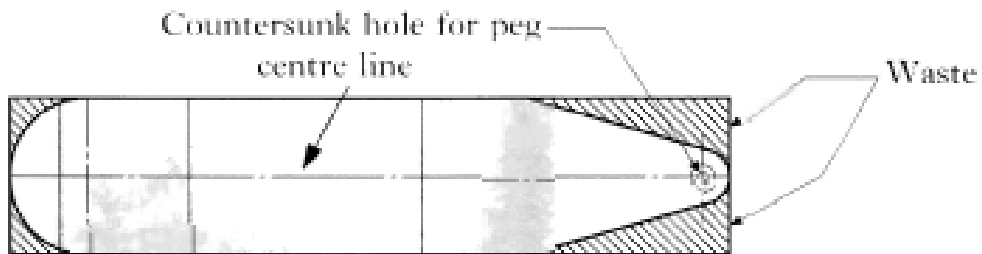

- (a) The centre line has to be marked on the metal.  
(i) Name the tool that should be used to find the centre and mark the centre line.

---

1

- (ii) Describe how this tool is used to find the centre.

---

---

---

---

---

2

(b) (i) Name the saw that can be used to cut off most of the waste material.

\_\_\_\_\_

1

(ii) Describe how the blade can be changed on this saw. Sketches can be used to illustrate your answer.

\_\_\_\_\_

\_\_\_\_\_

\_\_\_\_\_

\_\_\_\_\_

\_\_\_\_\_

\_\_\_\_\_

2

(c) Explain how the pillar drill can be set to a suitable depth for countersinking. Sketches may be used to illustrate your answer.

\_\_\_\_\_

\_\_\_\_\_

\_\_\_\_\_

\_\_\_\_\_

\_\_\_\_\_

\_\_\_\_\_

1

(d) Name the process that will soften the brass to make it easier to bend.

\_\_\_\_\_

1

(e) (i) Lacquer is applied to the brass. Give one reason why this is a suitable finish.

---

---

1

(ii) Give two methods of applying lacquer.

Method 1 \_\_\_\_\_

---

2

Method 2 \_\_\_\_\_

---

3. A scooter designed for city life is shown.

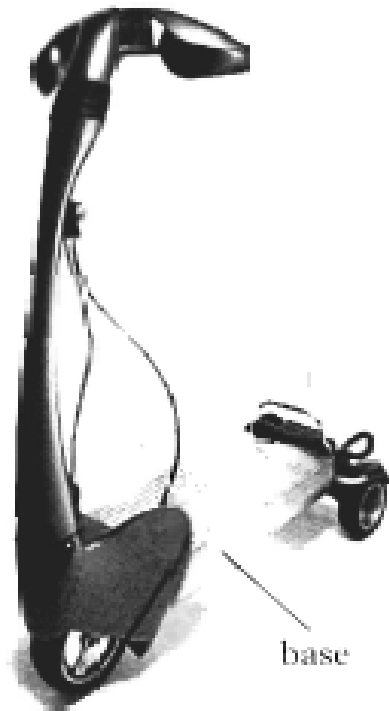

(a) The electrical wires are made from a ductile metal.

(i) State the name of a suitable metal.

---

1

(ii) Describe what is meant by the term *ductile*.

---

---

1

- (c) (i) Blind holes are drilled into the casting to aid the attachment of other components. Explain the term *blind hole*.

---

---

---

1

- (ii) A tap can be easily broken when threading a blind hole. Describe a method of preventing this from happening.

---

---

---

---

1

1. The image below shows a pan which has been designed to make it easier to lift.

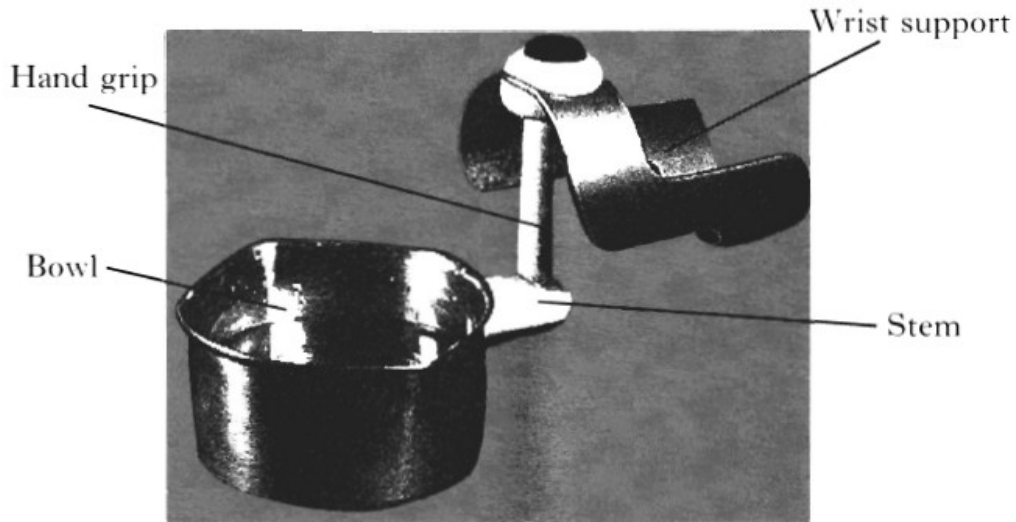

(a) (i) An alloy was one of the materials used in the construction. Explain what is meant by the term *alloy*.

1

(ii) Only one part of the pan has been made from a material which is a conductor of heat. State which part.

1

(iii) The other parts of the pan are made from non-conductive materials. Name one suitable non-conductive material.

1

2. A stand to display plastic bottles in a garage forecourt is shown below.

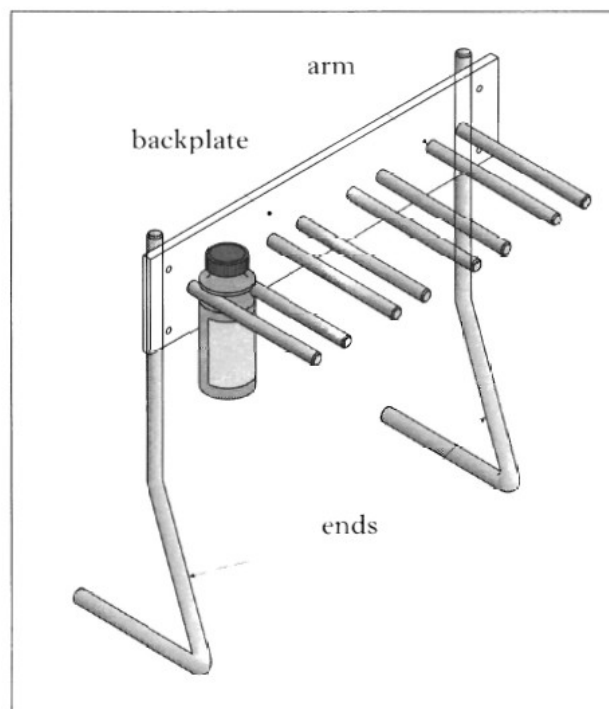

1  
1  
1

(a) (i) The material chosen by the designer was mild steel because it is malleable. Explain the term *malleable*.

---

---

1

(ii) Describe a method of ensuring that both ends of the stand are bent to an identical shape.

---

---

---

1

(b) The arms are machined on the lathe.

(i) Describe one method of checking that the lathe tool is set at the correct centre height.

---

---

---

---

2

The machining process on the ends of arm are shown at A and B.



(ii) Name the turning process carried out at:

End A \_\_\_\_\_

End B \_\_\_\_\_

2

(c) The arm could be fixed to the back plate in a variety of ways. Name a suitable method of:

Permanent fixing \_\_\_\_\_

Non-permanent fixing \_\_\_\_\_

2

3. A design for a wall mounted lamp is shown below.

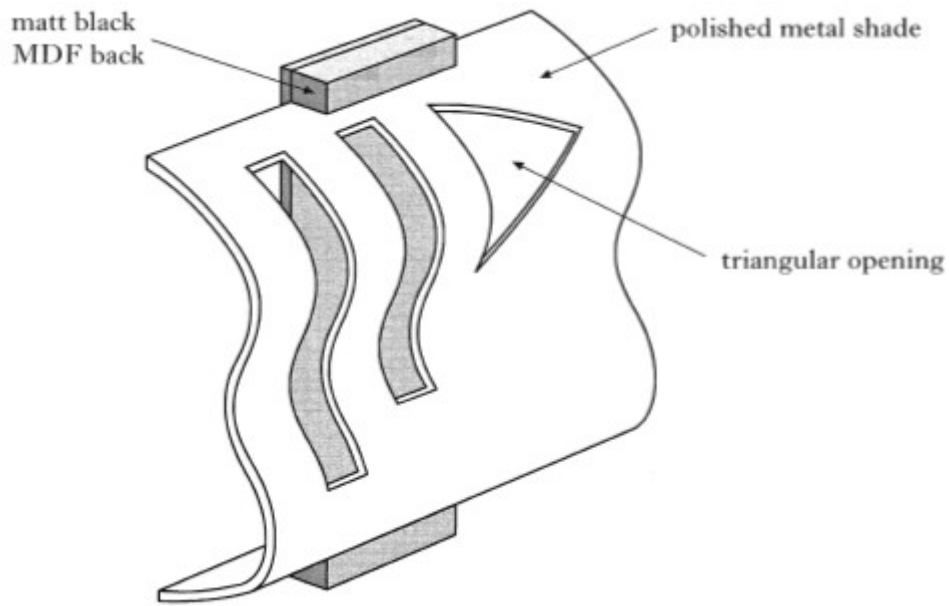

(a) The shade is to be made from a non-ferrous metal. State the name of a suitable metal.

\_\_\_\_\_

1

(b) When forming the shade, the metal became work-hardened. To make the metal more malleable, it will have to be annealed. Explain the following terms:

Work-hardened \_\_\_\_\_

\_\_\_\_\_

Annealed \_\_\_\_\_

\_\_\_\_\_

2

(c) An incomplete sequence of operations for cutting and finishing the triangular opening is shown below. Complete the table.

| Step        | Tools               |
|-------------|---------------------|
| 1. Mark out | Scriber, steel rule |
| 2.          |                     |
| 3.          |                     |
| 4.          |                     |
| 5.          |                     |
| 6. Finish   | Emery cloth         |

4

4. A metalwork lathe was used to turn the brass fixing shown below.

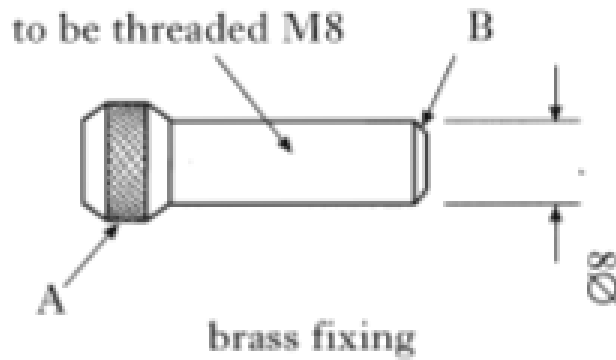

(a) State the name of the process carried out at A and B.

A \_\_\_\_\_ 2

B \_\_\_\_\_

(b) State a reason for this process being carried out at B.

\_\_\_\_\_ 1

(c) State the name of the tool that could be used to accurately measure the diameter of the brass fixing.

\_\_\_\_\_ 1

5. A small picture frame is shown below.



(a) The frame is made by pouring molten aluminium into a sand mould.

(i) State the name of this manufacturing process.

\_\_\_\_\_ 1



(ii) State which property of aluminium makes it a suitable material for this process.

\_\_\_\_\_

1

(iii) Describe one step in the preparation of the sand mould that will ensure the picture frame has a good finish.

\_\_\_\_\_

1

(b) Tapers and rounded corners are common features of most patterns. State the purpose of the:

Tapers \_\_\_\_\_

2

Rounded corners \_\_\_\_\_

1. A sketch of a table lamp is shown below.

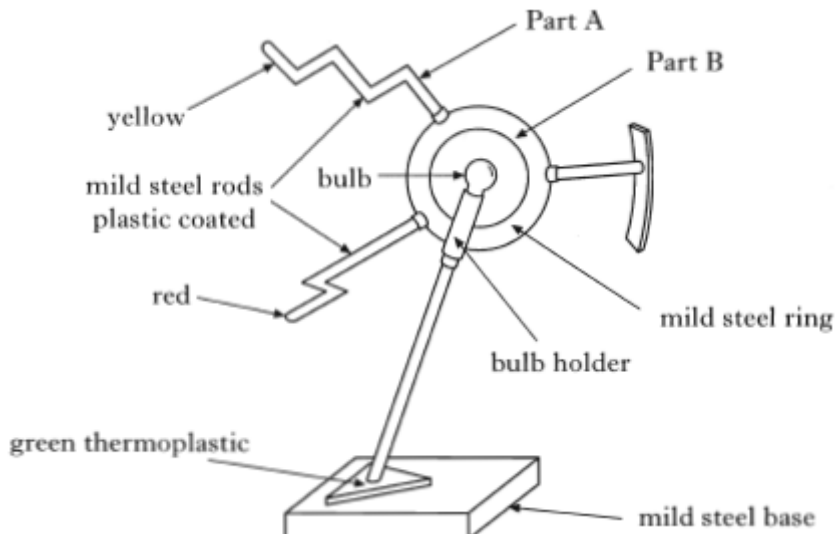

- (a) (i) Part A was *dip coated*. Describe the dip coating process. Sketches may be used to illustrate your answer.

---



---



---



---



---



---

3

- (ii) State the most likely reason the which would cause the plastic coating to look dull and gritty after being dip coated.

---



---

1

- (b) (i) A blind hole was drilled in Part B. Explain the term *blind hole*.

---



---



---

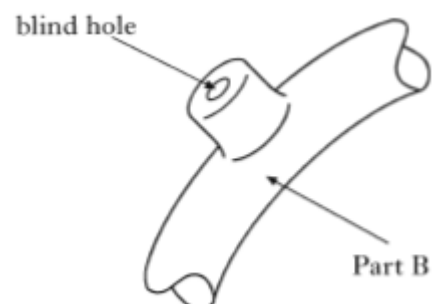

1

(ii) State why particular care must be taken when threading a blind hole.

---

1

(iii) State the name of the last tap that should be used when threading a blind hole.

---

1

(c) The tool shown below was used to cut the thread on one end of Part A.

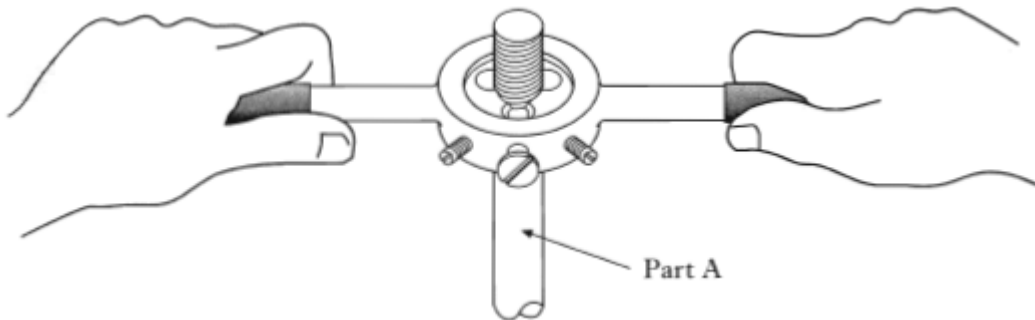

(i) State the name of this tool.

---

1

(ii) Explain why the thread on Part A was cut **after** the thread in Part B.

---

1

2. A set of wind chimes is shown below.

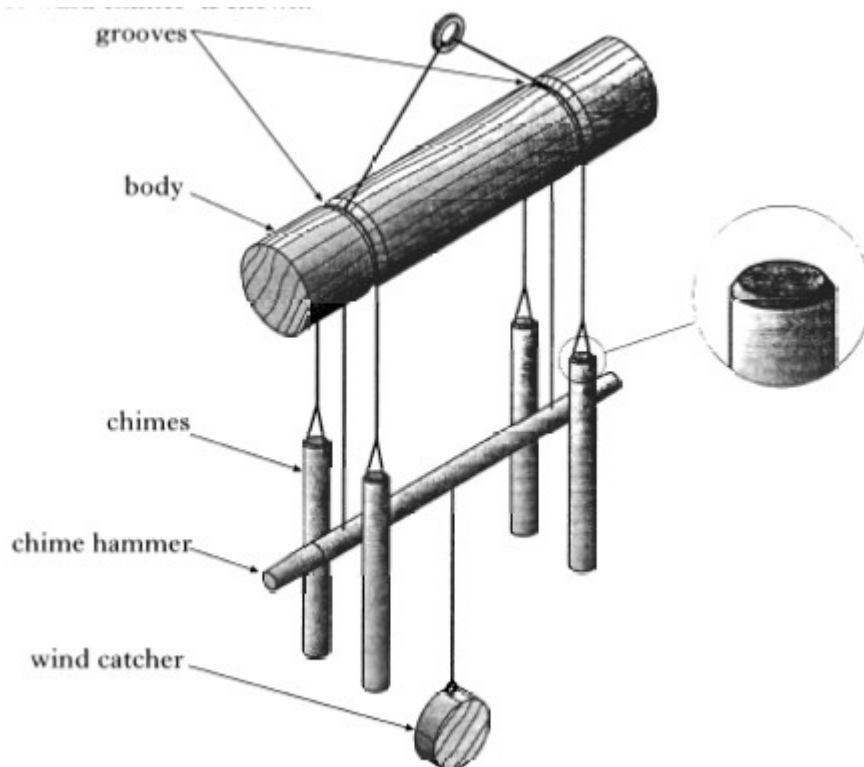

- (s) (i) The 'chimes' are faced off on the metal lathe.

Describe what would happen if the lathe tool was **not** set to the correct height.

---

---

1

- (ii) Describe how the height of the cutting tool is checked before 'facing off'. Sketches may be used to illustrate your answer.

---

---

---

---

2

- (b) The chime hammer is shown below.

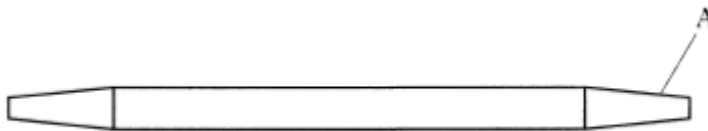

- (i) State the name of the turning process shown at A.

---

1

- (ii) State the name of the slide that would be adjusted on the lathe to allow this process.

---

1

- (c) State two general reasons why the speed of the lathe may need to be changed.

1. 

---

2. 

---

2

3. A pupil's design for a clock is shown.

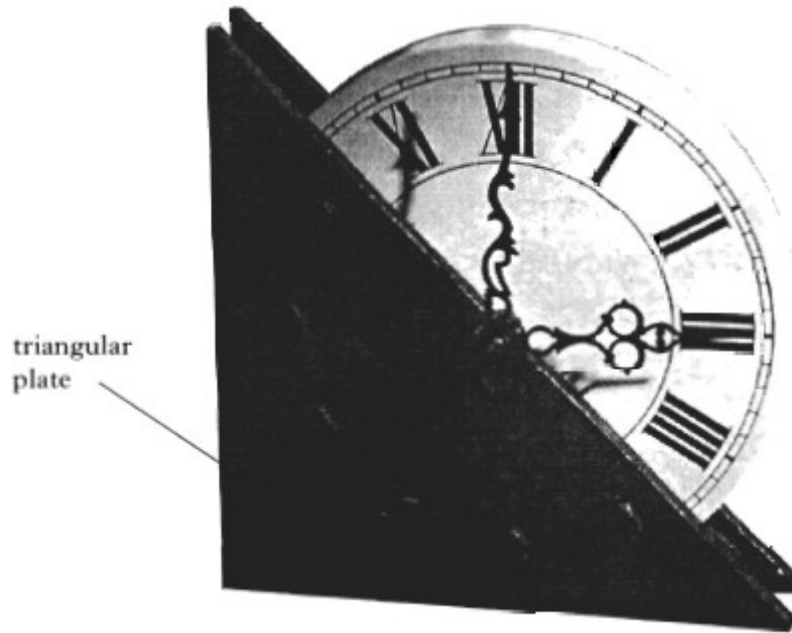

(a) M10 internal threads are cut into the triangular plate.

(i) State the name of the first taps used to cut the threads.

\_\_\_\_\_

1

(ii) State two procedures that would ensure a high quality thread is cut.

1. \_\_\_\_\_

2

2. \_\_\_\_\_

4. A chair is shown below.

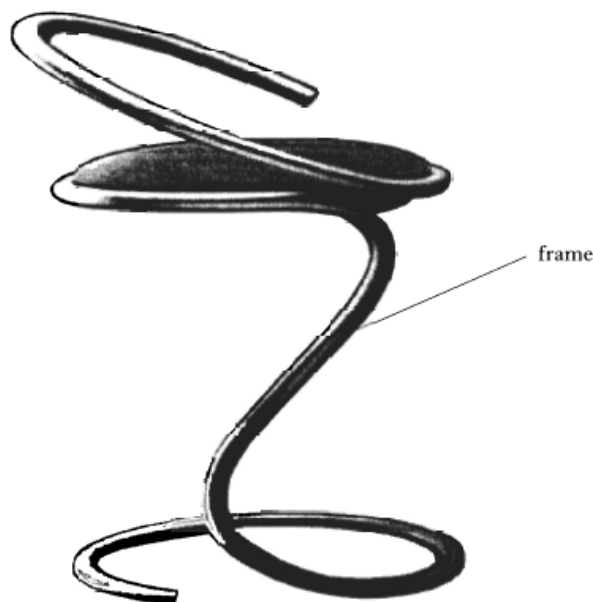

- (a) (i) The frame was modelled using malleable wire. Explain the term *malleable*.

\_\_\_\_\_

1

- (ii) State the name of a suitable material for the wire.

\_\_\_\_\_

1

- (b) Stainless steel tube was used in the final production of the chair frame. State **two** reasons for the choice of this material.

1. \_\_\_\_\_

2. \_\_\_\_\_

2

5. The mirror shown below has been designed in the style of Charles Rennie Mackintosh.

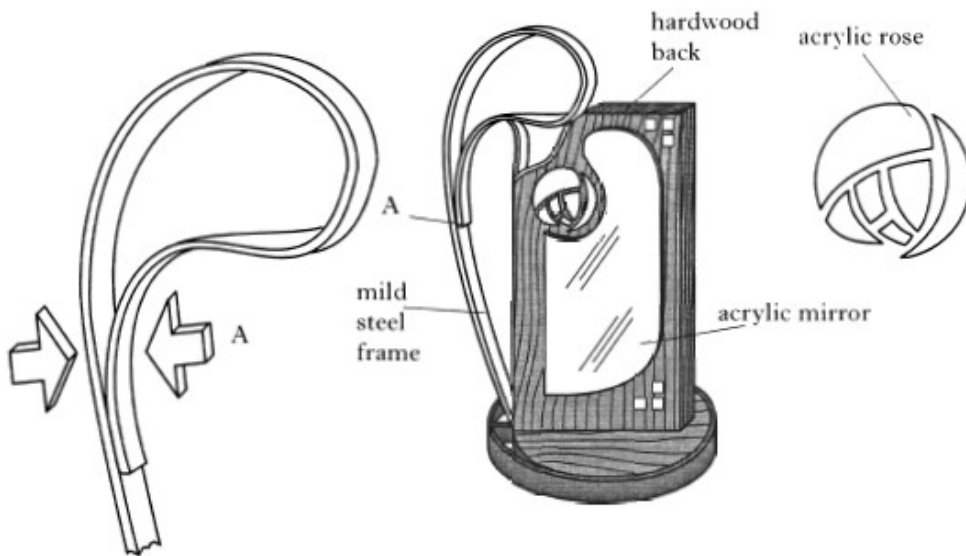

- (a) The mild steel frame was joined together using the spot welder, then finished with a matt paint.

- (i) Describe the process of spot welding. *You may use sketches to illustrate your answer.*

\_\_\_\_\_  
 \_\_\_\_\_  
 \_\_\_\_\_  
 \_\_\_\_\_

2

- (ii) State two stages in preparing the mild steel frame before applying the matt paint.

Stage 1 \_\_\_\_\_

\_\_\_\_\_

Stage 2 \_\_\_\_\_

\_\_\_\_\_

1. The chair shown below has been designed using the theme of the human skeleton.

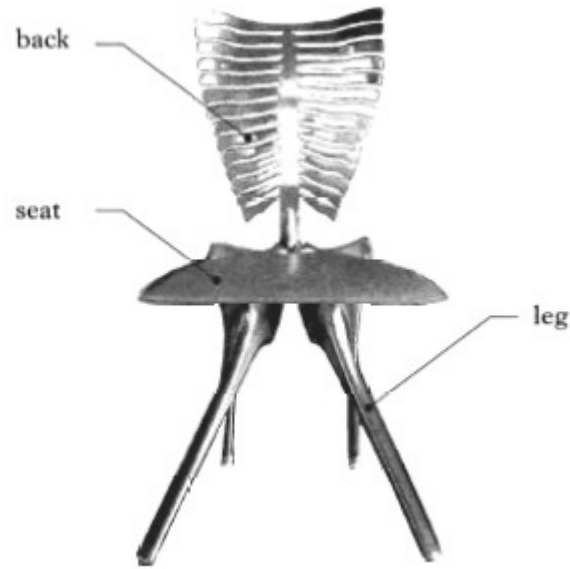

- (a) The back and legs of the chair are to be cast.  
The material used must:
- be lightweight
  - be light in colour
  - have a relatively low melting temperature.

State the name of a suitable metal.

\_\_\_\_\_

1

- (b) A pattern was used during the casting process. High quality surfaces, rounded corners and tapered edges are common features of patterns.  
State **two** reasons for these features.

1. \_\_\_\_\_

2. \_\_\_\_\_

2

2. The metal candle holder shown below was turned on a metal lathe.

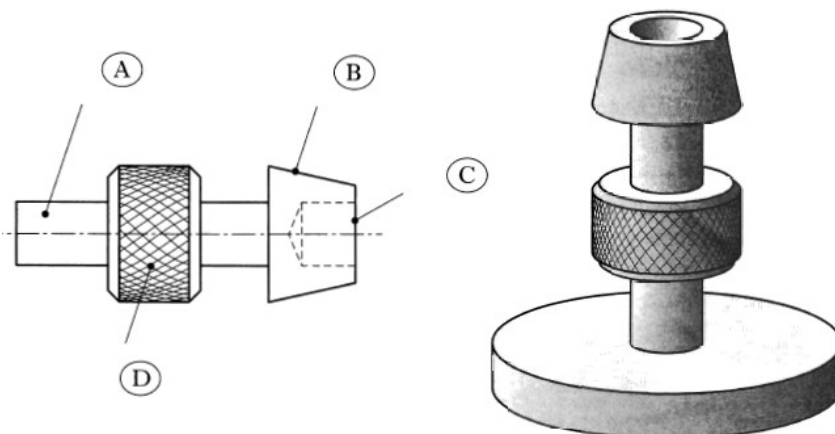



(a) State the name of a suitable non ferrous material that could be used for the candle holder.

\_\_\_\_\_

1

(b) State the name of the process of reducing the diameter at A.

\_\_\_\_\_

1

(c) State the name of the slide that would be adjusted on the lathe when turning the taper at B.

\_\_\_\_\_

1

(d) State a method of achieving a good finish when turning the taper at B.

\_\_\_\_\_

1

(e) The hole at C is to be drilled 20mm deep.  
Describe a method of ensuring that the hole is drilled to the correct depth. *Sketches may be used to illustrate your answer.*

\_\_\_\_\_  
\_\_\_\_\_  
\_\_\_\_\_  
\_\_\_\_\_

2

(f) State the name of the lathe tool used to produce the finish at D.

\_\_\_\_\_

1

(g) State the purpose of the finish at D.

\_\_\_\_\_

1

(h) Part 1 of the candle holder is joined to Part 2 with an M8 thread as shown below.

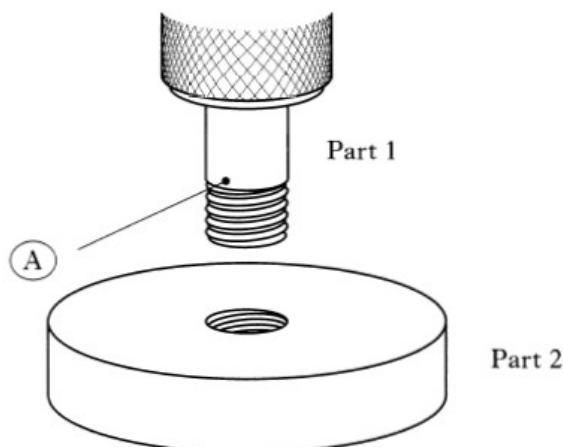

- (i) State the diameter of A which would allow an M8 thread to be cut.

---

1

- (ii) The hand tool shown below was used to cut the thread.

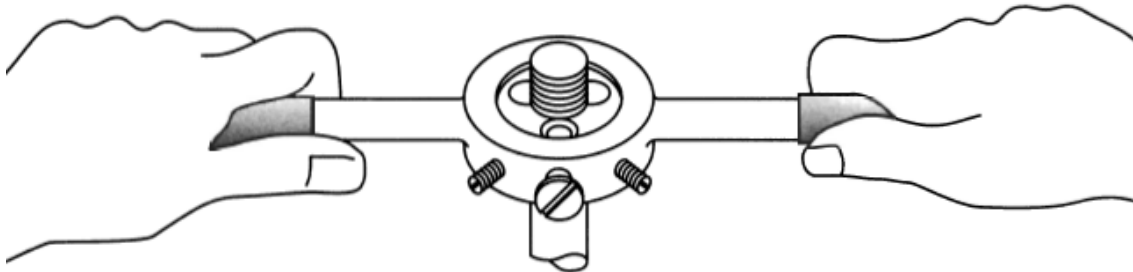

State the name of this tool.

---

1

- (ii) The fit of the thread was found to be tight. Describe how the tool could be adjusted to achieve a better fit. *(Sketches may be used to illustrate your answer.)*

---

---

---

---

2

- (i) State a reason for producing the candle holder in two parts.

---

1

3. A sketch of a mini torch is shown below.

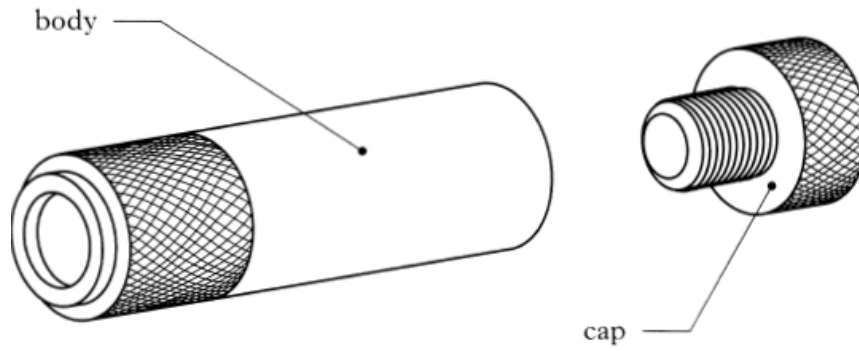

The stages of the manufacture of the torch are shown below.

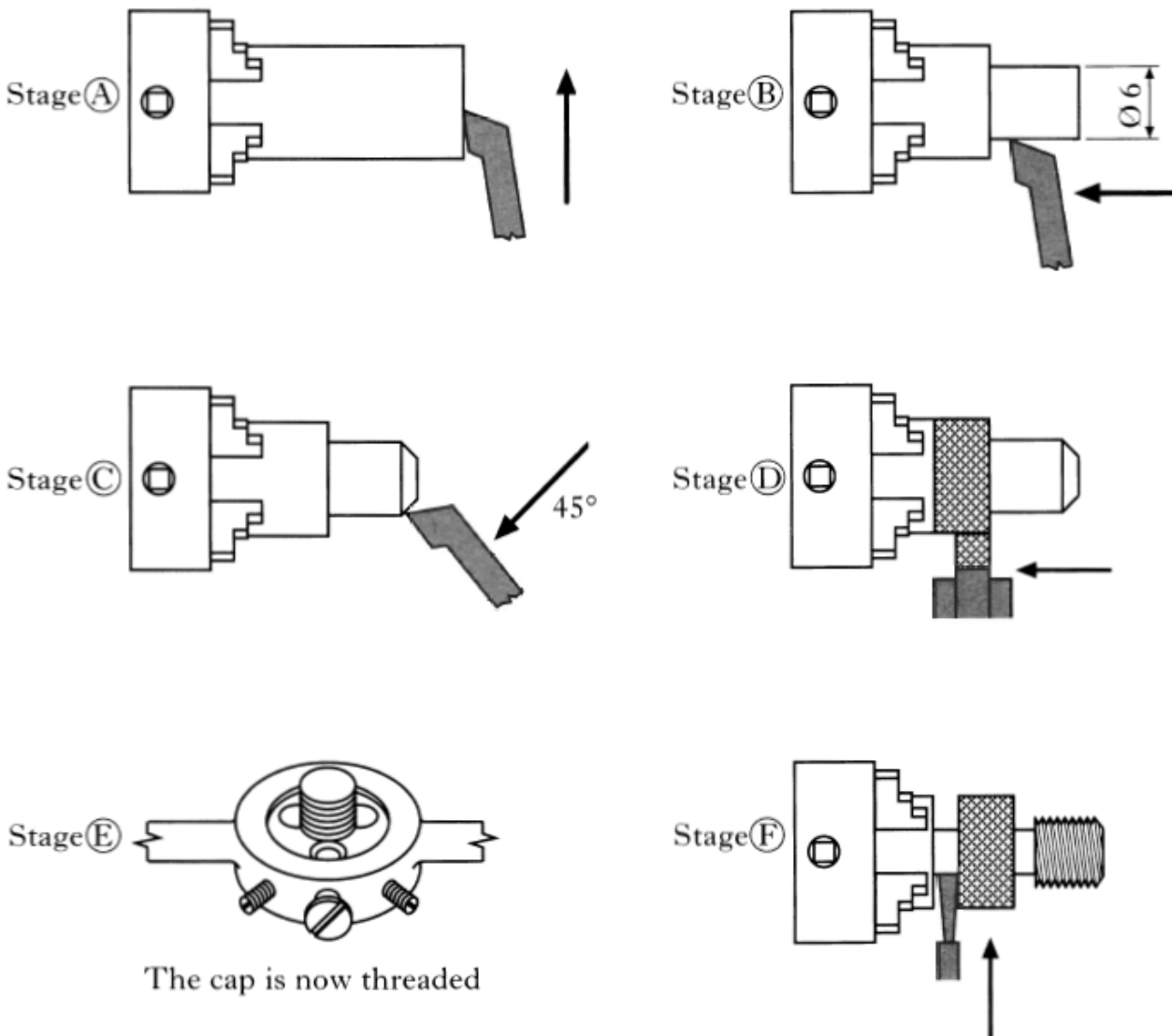

(a) State the name of the process used at Stage B.

---

(b) State the name of the process used at Stage D.

---

(c) State two reasons why a change in lathe speed may be necessary when turning the cap.

1. \_\_\_\_\_

2. \_\_\_\_\_

2

(d) State the name of the tool used to accurately measure  $\varnothing 6\text{mm}$  at Stage B.

\_\_\_\_\_

1

(e) *Other than safety*, state a reason for the  $45^\circ$  chamfer at Stage C.

\_\_\_\_\_

1

1. A pupil's design for a piece of jewellery is shown below.

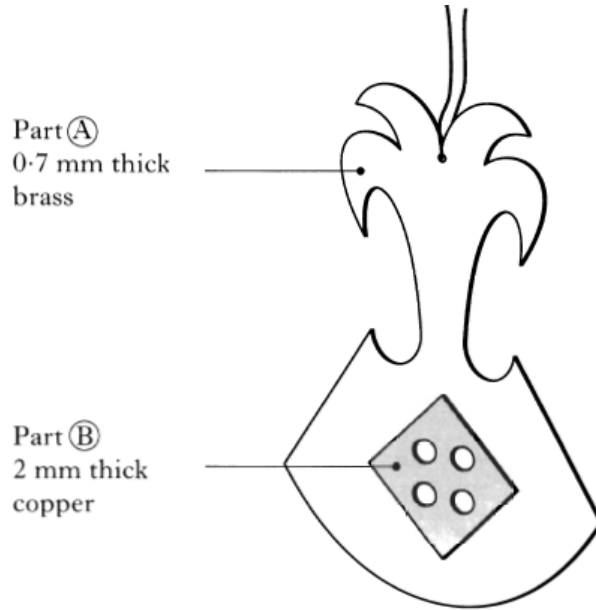

(a) Part A is made from brass which is an alloy. State what is meant by the term *alloy*.

---



---

1

(b) The positions of the four holes in Part B are shown below.

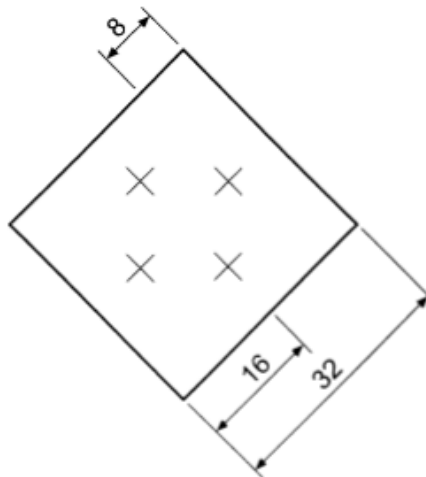

Describe how the centres of the holes could be marked out using odd leg calipers.  
*Sketches may be used to illustrate your answer.*

---



---



---



---

2

- (c) State the name of a suitable hand tool that could be used to remove the waste material when cutting Part A.

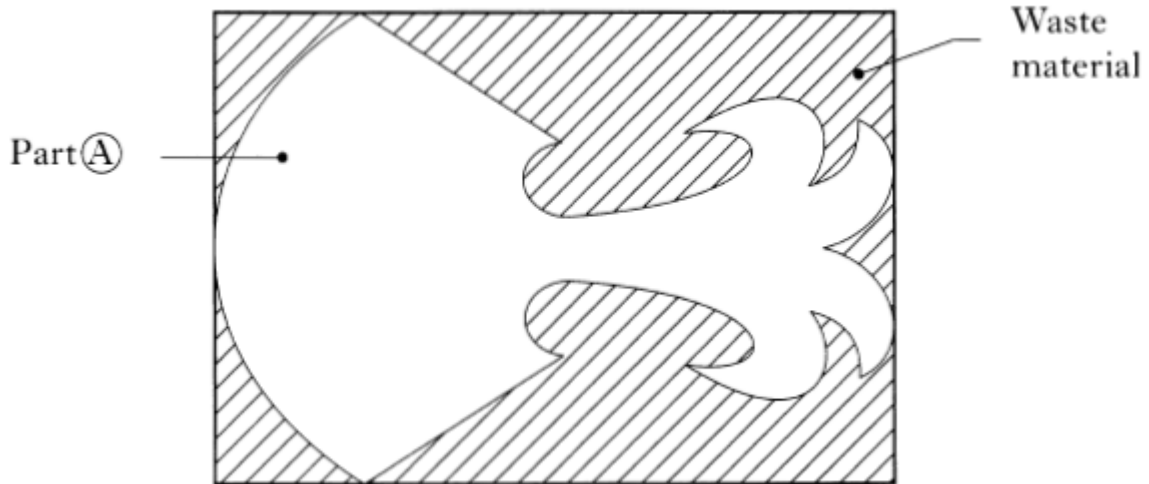

\_\_\_\_\_

1

- (d) Other than glue, state a suitable method of joining Part A to Part B.

\_\_\_\_\_

1

- (e) The jewellery was finished with clear lacquer. State two reasons for using this finish.

1. \_\_\_\_\_

2. \_\_\_\_\_

2

- 2. A design for a chair is shown below.

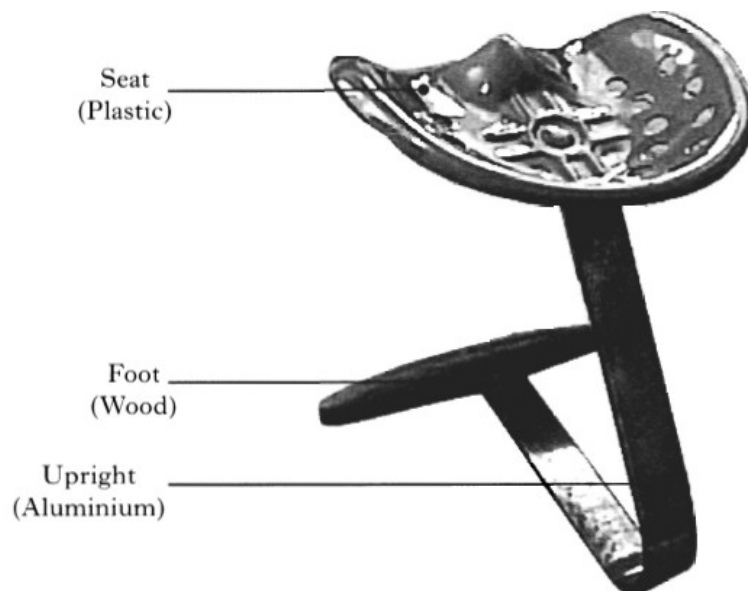

- (a) During the manufacture of the upright, the aluminium was annealed.

State a reason for annealing the aluminium.

---

---

1

- (b) Describe the process of annealing aluminium.

---

---

---

2

- 3. A school enterprise group designed and made the clock shown.

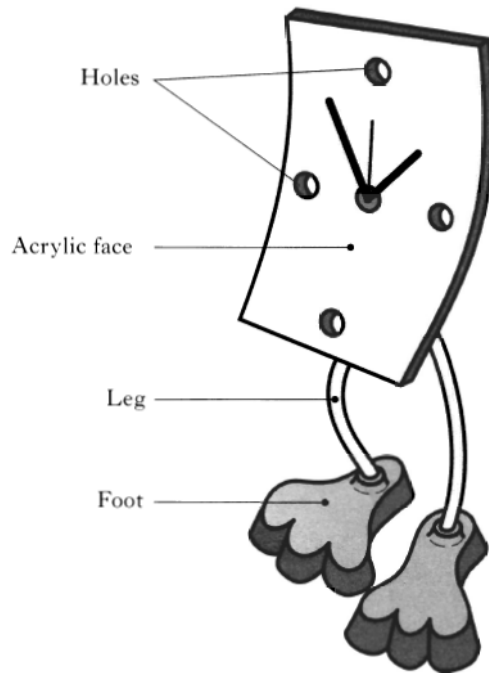

- (a) During the investigation, the group decided on using an aluminium casting for the feet.

State why aluminium is a suitable choice for this.

---

1

- (b) Casting was chosen as the method for manufacturing the feet.

- (i) State two important features which should be considered when producing the pattern for the feet.

1. \_\_\_\_\_

2. \_\_\_\_\_

2

- (c) While preparing the mould, small holes are made in the sand above the pattern. State a reason for these holes.

---

---

1

- (d) Each foot has to have a hole drilled in it to a depth of 15mm.

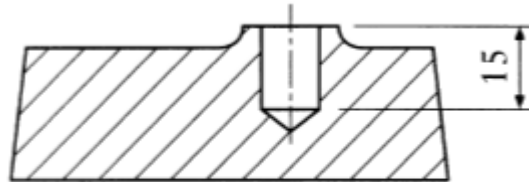

Section through foot

Describe how you would ensure that all of the feet are drilled to the same depth.  
*(You may use sketches to illustrate your answer.)*

---

---

---

---

2



1. A small hammer is shown below.

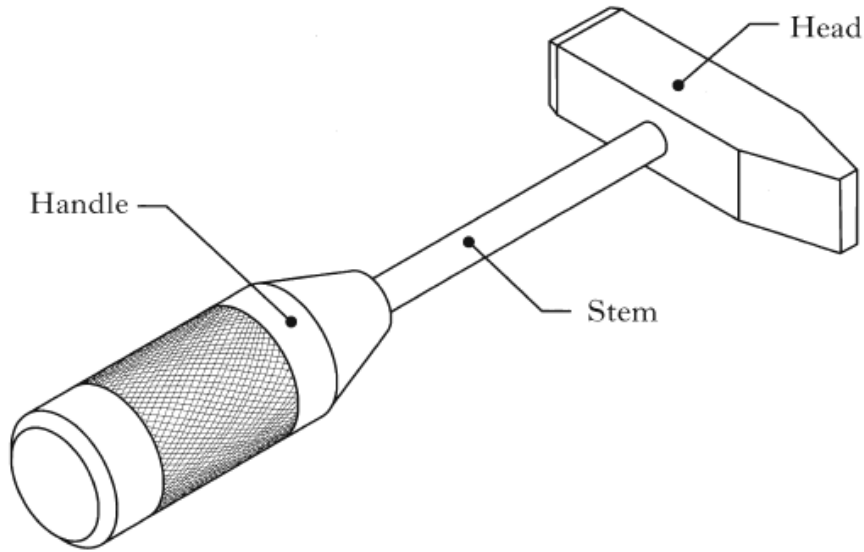

(a) Carbon steel and aluminium were considered as possible materials for the hammer.

(i) State a property of aluminium that makes it suitable for the handle.

\_\_\_\_\_

1

(ii) State a property of carbon steel that makes it suitable for the head.

\_\_\_\_\_

1

(b) The handle was machined on the metal lathe.

(i) State what the effect would be if the lathe tool was not centred when facing the end of the handle.

\_\_\_\_\_

1

(ii) State one method of checking that the lathe tool is set to the correct centre height. *(You may use sketches to illustrate your answer.)*

\_\_\_\_\_  
\_\_\_\_\_  
\_\_\_\_\_  
\_\_\_\_\_  
\_\_\_\_\_

1

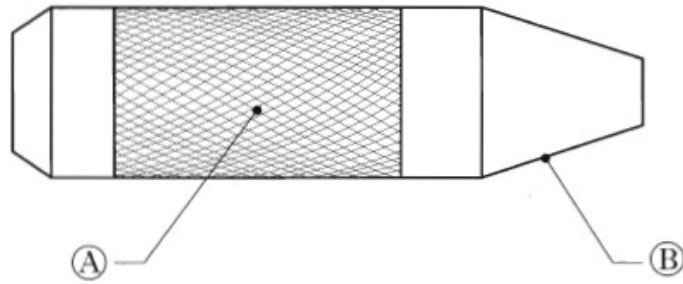

(iii) State an adjustment to the lathe that may be necessary before knurling surface A.

\_\_\_\_\_

1

(iv) State a functional reason for the finish at A.

\_\_\_\_\_

1

(v) State two procedures for achieving a smooth finish when carrying out the turning process at B.

1. \_\_\_\_\_

2. \_\_\_\_\_

2

(vi) The lathe tool shown below was used during the manufacture of the handle. State the name of this tool.



\_\_\_\_\_

1

(c) During the manufacture of the hammer, a blind hole was drilled in the head.

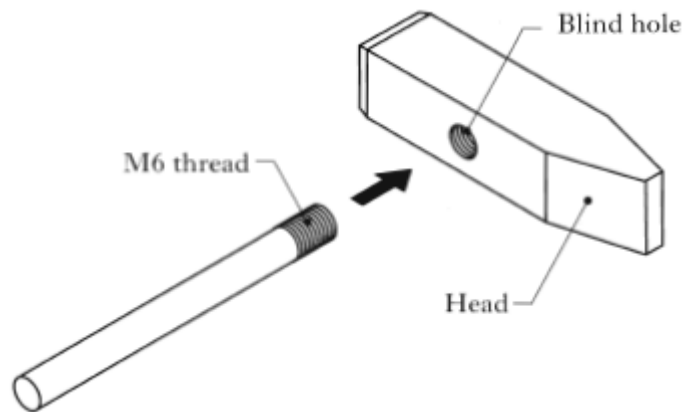

(i) Explain what is meant by the term *blind hole*.

---

---

1

(ii) State the name of the first tap used to cut the M6 thread.

---

1

(iii) State one method that will ensure a high quality thread is cut in the blind hole.

---

1

2. A pair of pliers is shown below.

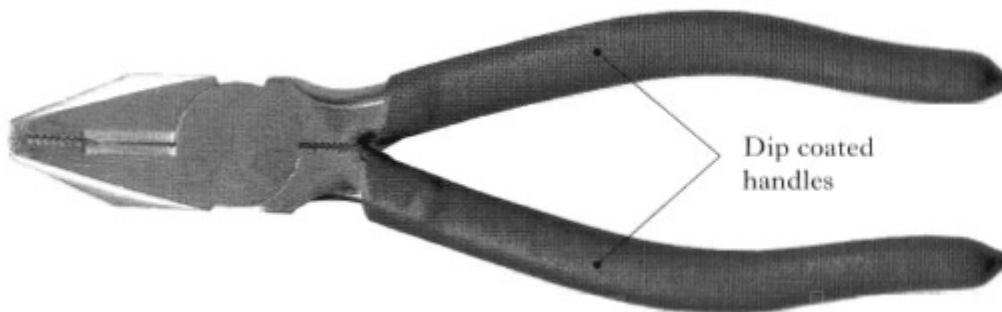

(a) Complete the sequence of operations for dip coating the handles.

1. Degrease and clean the material.

2. \_\_\_\_\_

3. \_\_\_\_\_

4. \_\_\_\_\_

3

(b) State the most likely reason why the plastic coating looked dull and gritty after dip coating.

---

---

1

(c) State two reasons why a thermoplastic is a suitable finish for the handles.

1. 

---

---

2. 

---

---

2

3. A table lamp is shown below.

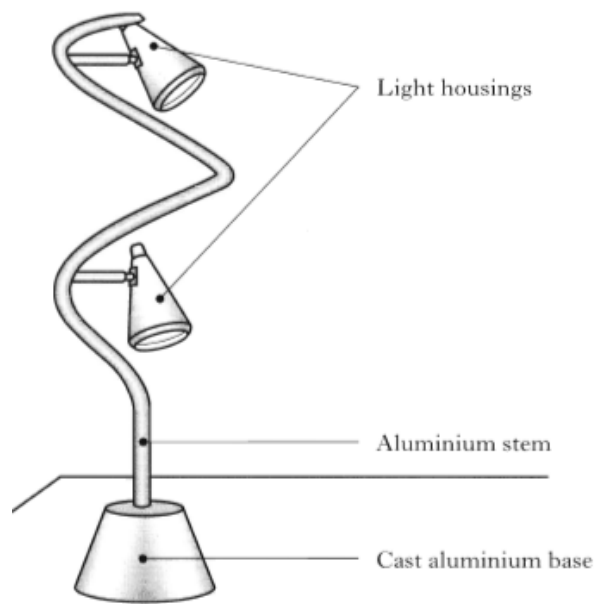

(a) (i) The stem was modelled using malleable wire.

Explain what is meant by the term *malleable*.

---

---

1

(ii) State the name of a malleable metal suitable for modelling the stem.

---

1

(b) In order to produce the aluminium casting, a wooden pattern was produced.

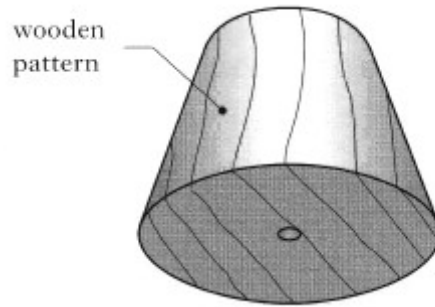

State two features of the pattern that would allow it to be easily removed from the moulding sand.

1. \_\_\_\_\_

2. \_\_\_\_\_

2

(c) During the process it was necessary to anneal the aluminium.

(i) State the purpose of annealing the aluminium.

\_\_\_\_\_

1

(ii) Describe the process of annealing aluminium.

\_\_\_\_\_

\_\_\_\_\_

\_\_\_\_\_

\_\_\_\_\_

2

1. A towel rail is shown below.

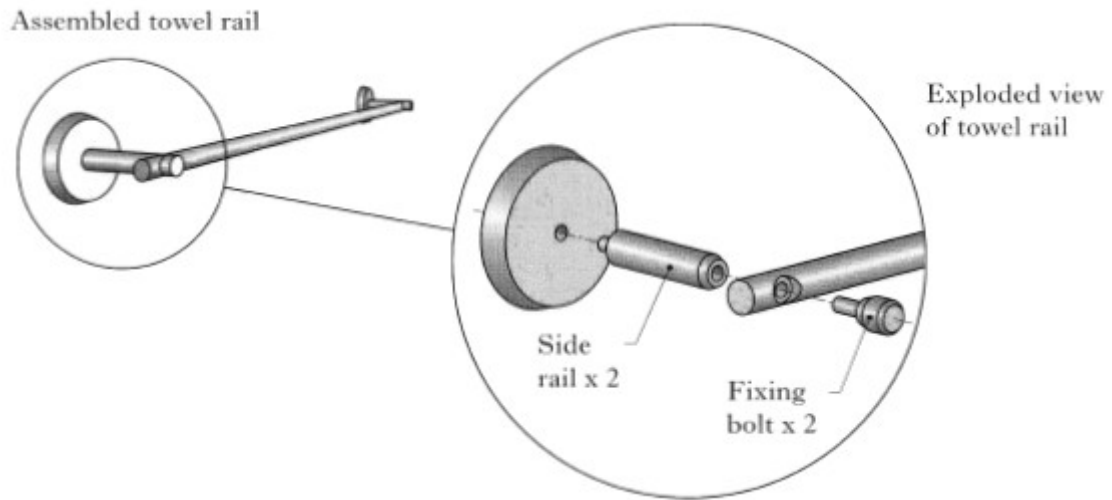

(a) The fixing bolts were manufactured using the metalwork lathe. State the names of the turning processes shown below:

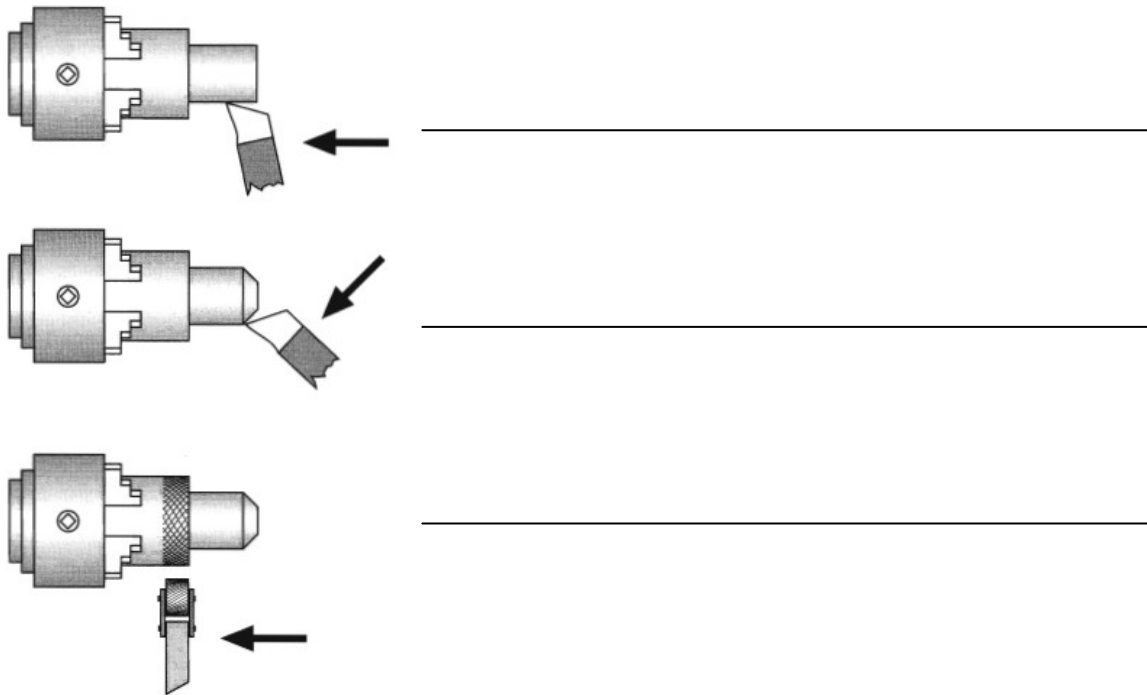

3

(b) State two reasons why a change in speed of the lathe may be necessary when turning the fixing bolts.

1. \_\_\_\_\_

2. \_\_\_\_\_

2

(c) The side rail is shown below:

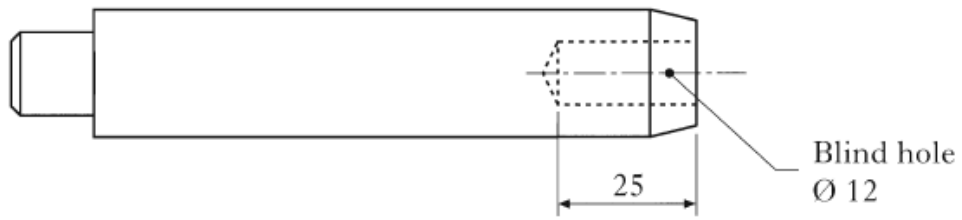

The blind hole is to be drilled using the metalwork lathe. Complete the sequence of operations for drilling the blind hole accurately to a depth of 25mm.

Stage 1 Face off the end of the bar.

Stage 2 \_\_\_\_\_  
\_\_\_\_\_

Stage 3 \_\_\_\_\_  
\_\_\_\_\_

Stage 4 \_\_\_\_\_  
\_\_\_\_\_

3

(d) A thread is to be cut in the blind hole.

(i) State why particular care should be taken when threading a blind hole.

\_\_\_\_\_

1

(ii) State the name of the first tap used when threading the blind hole.

\_\_\_\_\_

1

(iii) State the name of the last tap used when threading the blind hole.

\_\_\_\_\_

1

2. A coat hook is shown below.

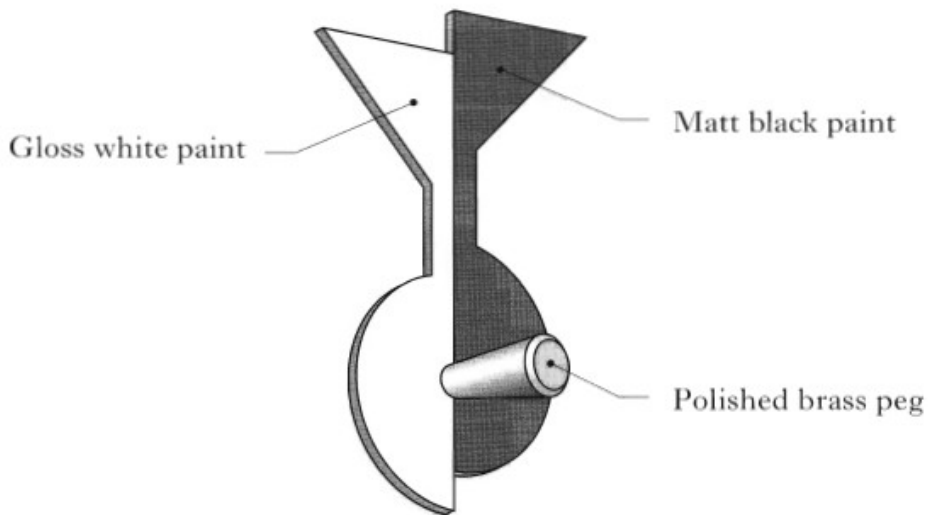

(a) The peg is shown below.

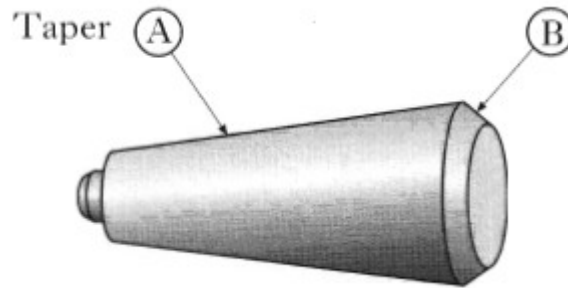

(i) State a functional reason for the peg being tapered at A.

\_\_\_\_\_

1

(ii) State a reason for removing the corner at B.

\_\_\_\_\_

1

(b) The peg is made from brass, a non-ferrous alloy. Explain what is meant by the terms:

Non-ferrous \_\_\_\_\_

Alloy \_\_\_\_\_

2



The back plate is made from 4mm steel.

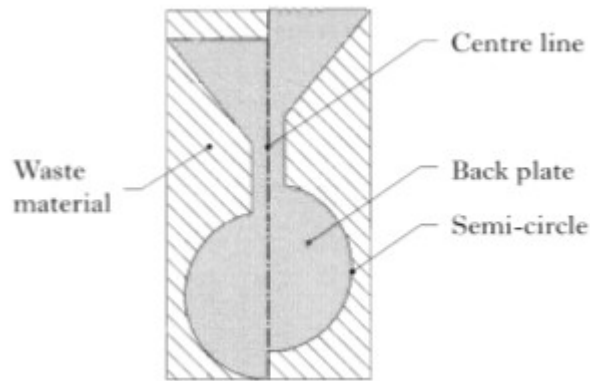

(c) Odd leg calipers were used in marking out the shape.

(i) Complete the sketch of the odd leg calipers shown below:



1

(ii) Describe how odd leg calipers can be used to find the centre of the blank material without using a rule. (You may use a sketch to illustrate your answer).

---



---



---



---



---

2

(d) State the name of the tool used to mark the semi-circles.

---

1

(e) State the name of a suitable hand tool used to remove the waste material from the back plate.

---

1

3. (a) A wall light is shown:

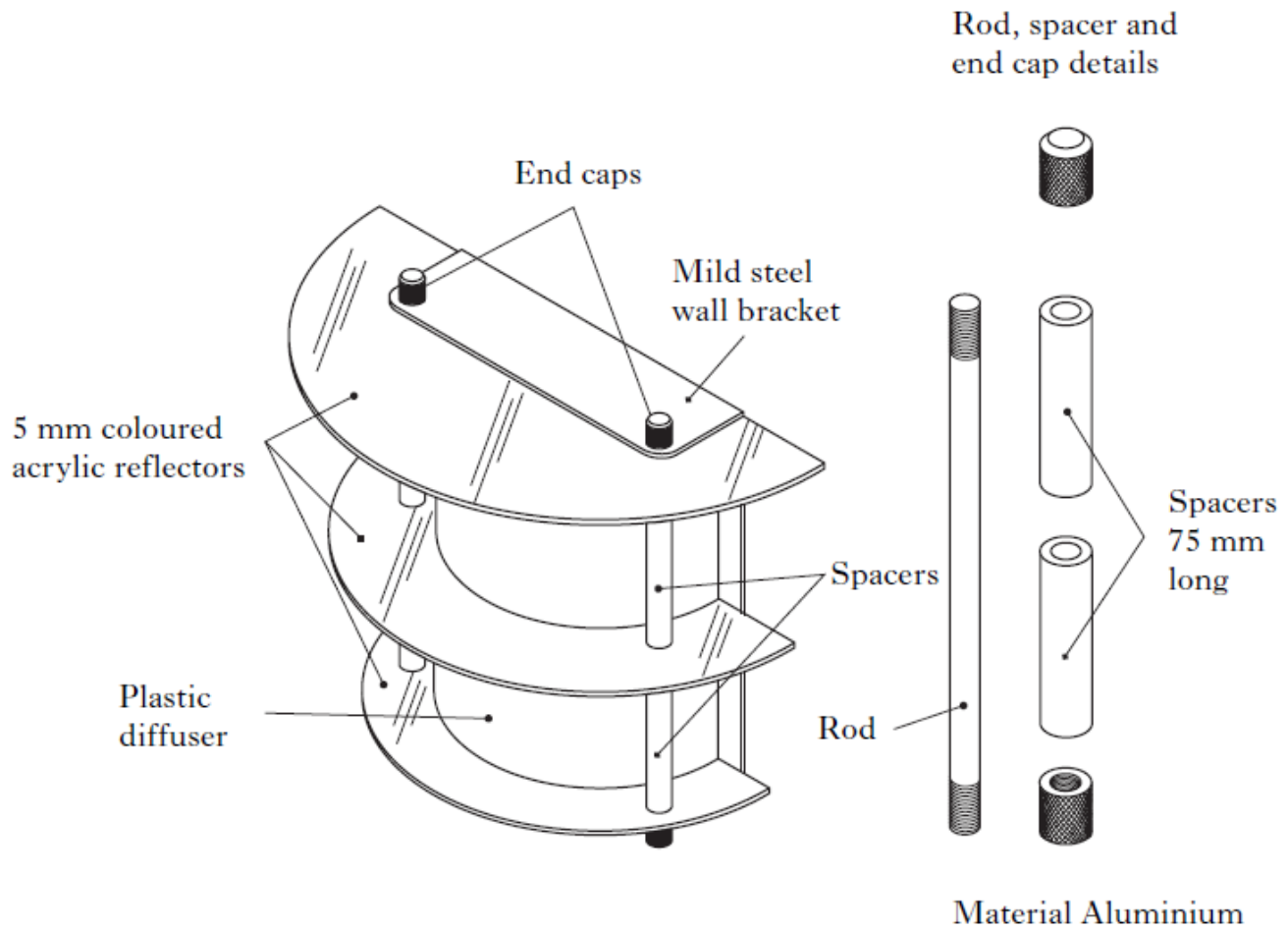

The mild steel for the wall bracket was marked out as shown.

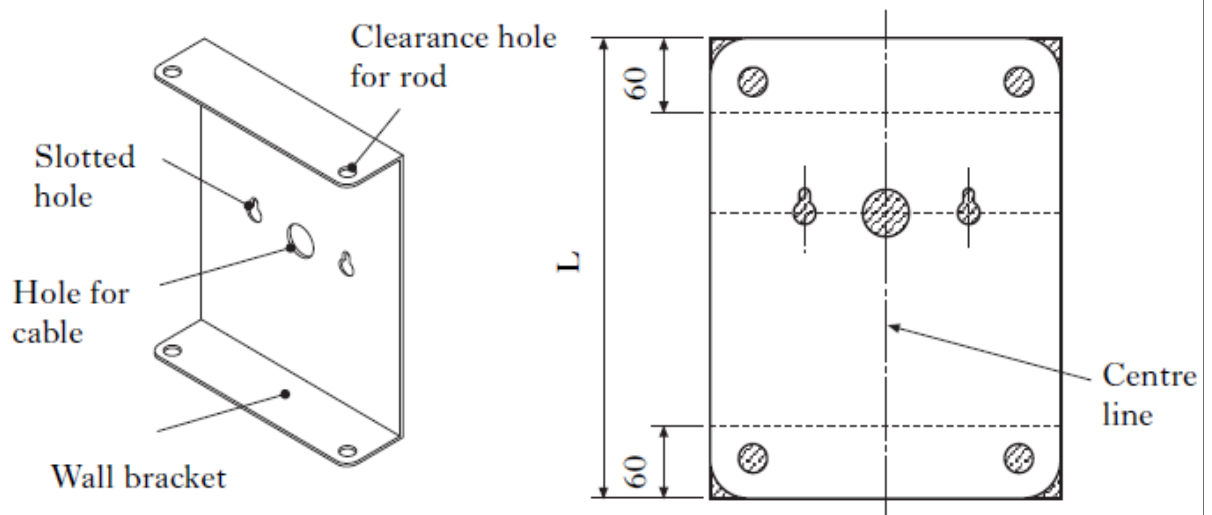

(i) Mild steel is a ferrous metal.

State what is meant by a ferrous metal.

- (ii) The wall bracket holds three acrylic reflectors and two spacers.

State the total length (L) of the material required for the bracket.

Total Length L \_\_\_\_\_

1

- (iii) A centre line was marked on the material for the wall bracket. Describe how odd leg calipers can be used to scribe a centre line without using a ruler. *(You may use sketches to illustrate your answer).*

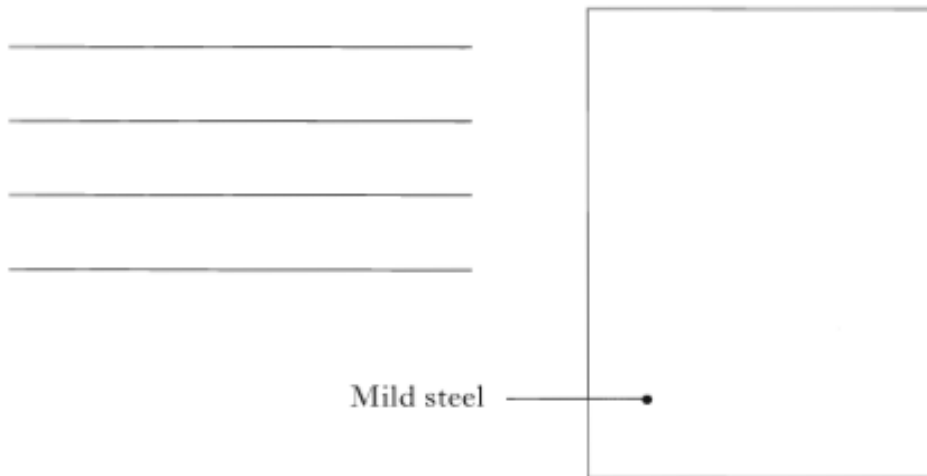

2

- (b) (i) The mild steel was drilled.

State a reason why the metal was centre punched before drilling.

\_\_\_\_\_

\_\_\_\_\_

1

- (ii) State a reason for the slotted holes in the wall bracket.

\_\_\_\_\_

\_\_\_\_\_

1

- (c) (i) The end caps were faced off using the metal lathe.

State one fault that would result in a small 'pip' forming on the cap during the turning.

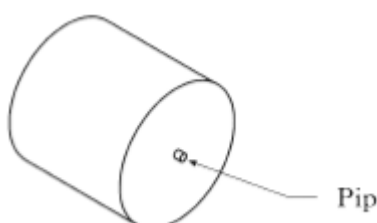

\_\_\_\_\_

\_\_\_\_\_

\_\_\_\_\_

\_\_\_\_\_

1

- (ii) During the manufacture of the end caps, the tool below was used.



State the name of this tool.

---

1

State the purpose of this tool.

---

1

- (iii) A metal lathe was used when drilling a blind hole in each end cap.

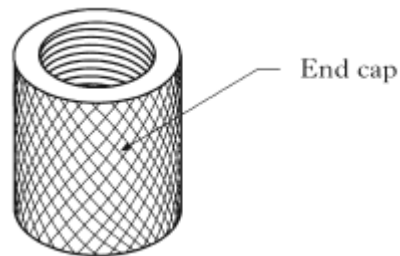

Describe a method of ensuring the depth of the blind hole is 30mm.

---

1

---

- (d) (i) Taps were used to thread the blind holes.

State the name of the last tap used when threading a blind hole.

---

1

- (ii) The tool shown below was used to cut an external thread on the rod.

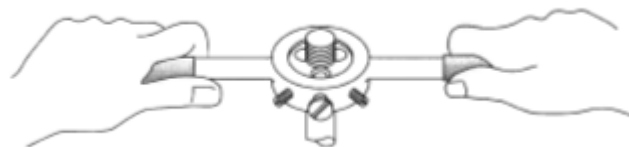

State the name of this tool.

---

1

(iii) The thread was found to be a tight fit. Describe how to adjust this tool to ensure a good fitting thread.

---

---

---

1

(e) The end caps were knurled.

State an adjustment to the lathe that may be necessary prior to knurling.

---

1

1. A metal gate is shown below:

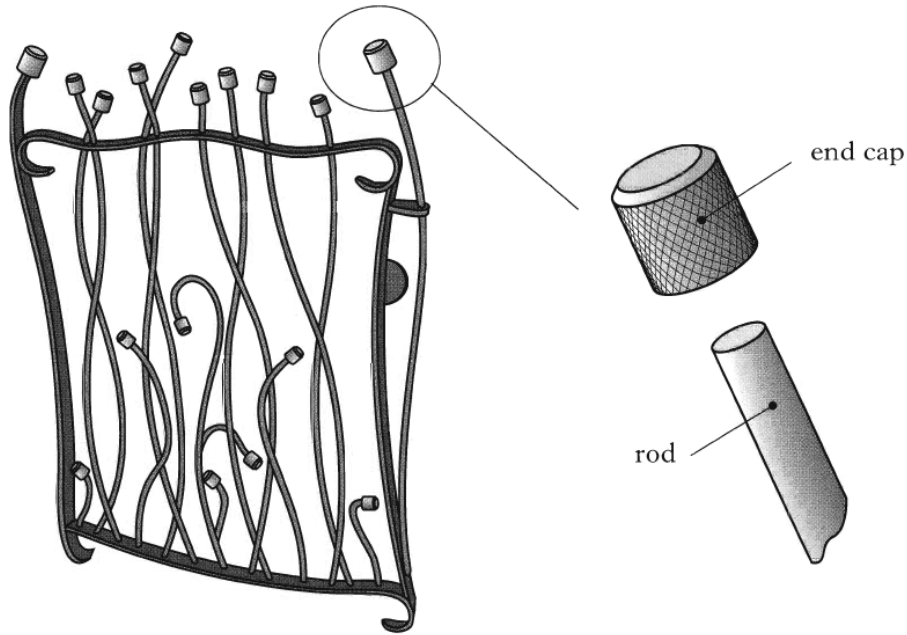

(a) The end caps were manufactured using the metal lathe.

(i) State the names of the turning processes shown below.

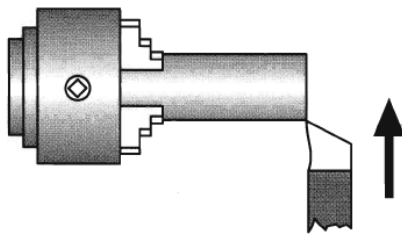

Process A

\_\_\_\_\_

1

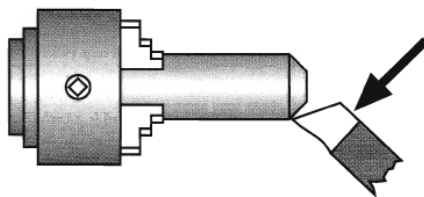

Process B

\_\_\_\_\_

1

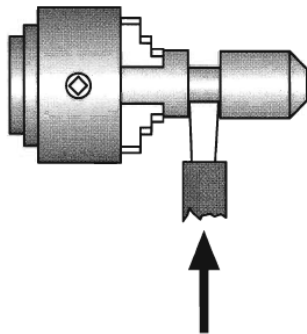

Process C

\_\_\_\_\_

1

(ii) State **two** reasons why a change in speed on the lathe may be necessary when turning metal.

1. \_\_\_\_\_

2. \_\_\_\_\_

2

(b) One end of each rod is threaded.

(i) State the diameter of the rod required for an M6 thread to be cut.

\_\_\_\_\_

1

(ii) State how the end of the rod should be prepared for threading.

\_\_\_\_\_

1

(iii) State the name of the tool used to cut the thread on the end of the rod.

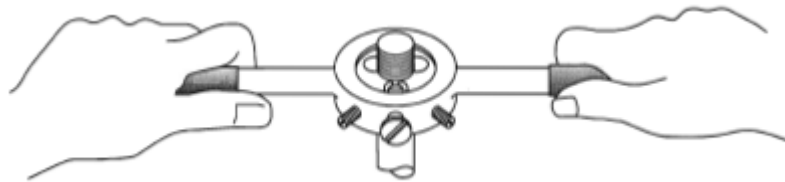

\_\_\_\_\_

(iv) State **two** procedures that would ensure a high quality thread is cut.

1. \_\_\_\_\_

2. \_\_\_\_\_

2

(v) The thread between the end cap and the rod was found to be a tight fit. Describe an adjustment that could be made to ensure a good fitting thread.

\_\_\_\_\_

\_\_\_\_\_

\_\_\_\_\_

\_\_\_\_\_

2

2. A clock is shown:

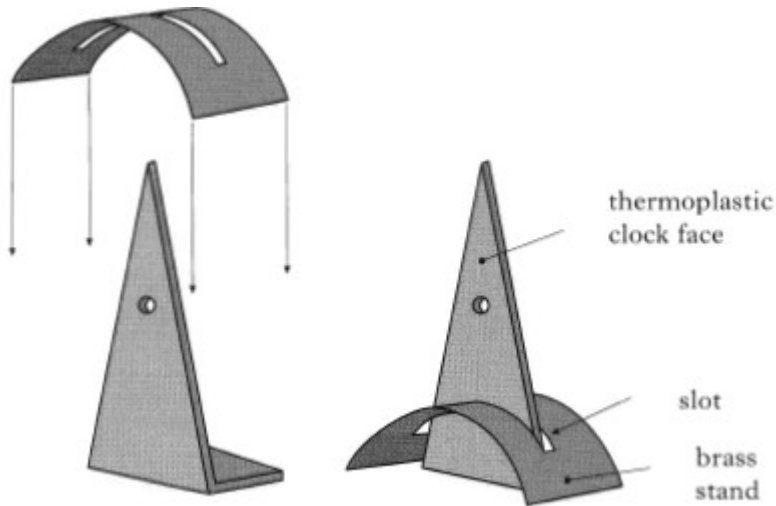

- (a) The stand is made from brass sheet. Brass is an alloy.  
Explain what is meant by the term *alloy*.

---

- (b) Odd leg calipers were used to mark the centre line of the slot on the brass sheet as shown.

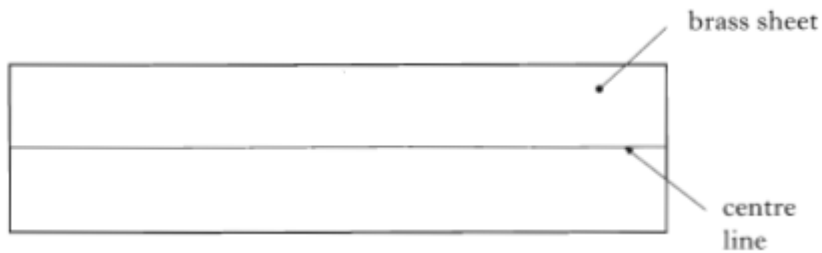

Describe a method of setting the odd leg calipers to half the width of the brass sheet without the use of a rule. Sketches may be used to illustrate your answer.

---

---

---

---

---

---



(c) A hide mallet and former were used to shape the brass sheet.

State a reason for using a hide mallet instead of a ball peen hammer.

\_\_\_\_\_

1

(d) The brass sheet work hardened when shaped. It was annealed to make it malleable.

Explain the terms work hardened, annealed and malleable.

1. Work hardened \_\_\_\_\_

2. Annealed \_\_\_\_\_

3. Malleable \_\_\_\_\_

3

3. A stainless steel park bench is shown below.

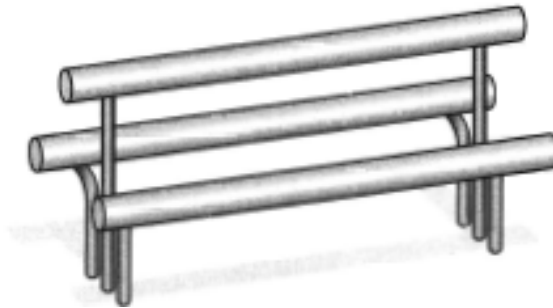

(a) Stainless steel, a ferrous metal was used in the manufacture of the bench.

(i) State what is meant by the term ferrous metal.

\_\_\_\_\_

1

(ii) State two reasons why stainless steel is a suitable material for the bench.

1. \_\_\_\_\_

\_\_\_\_\_

2. \_\_\_\_\_

\_\_\_\_\_

2

- (b) The bolt shown below is used to assemble the bench.

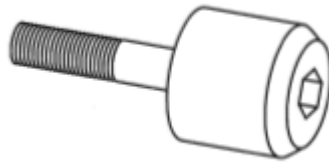

Some of the processes used to manufacture the bolt on a metal lathe are shown below.

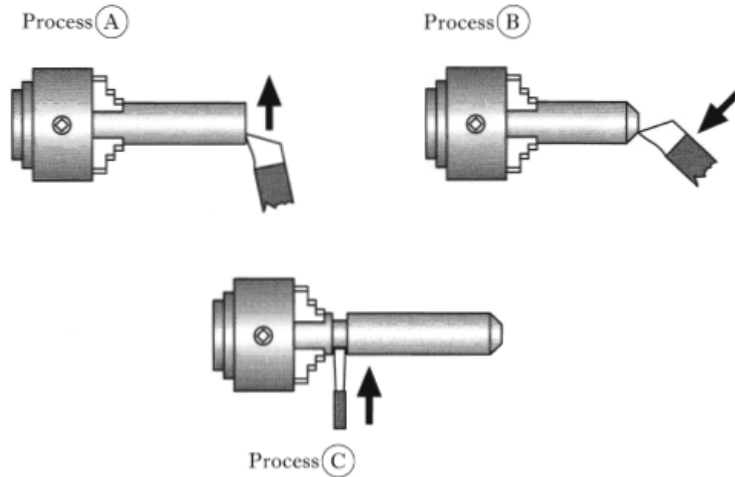

- (i) State a reason for the 45° chamfer at process B.

\_\_\_\_\_

1

- (ii) State the name of the slide that would need to be adjusted when turning the chamfer at process B.

\_\_\_\_\_

1

- (iii) State the name of the cutting tool used in process C.

\_\_\_\_\_

1

- (iv) State **two** procedures or adjustments that ensure a high quality finish is achieved when turning metal.

1. \_\_\_\_\_

2. \_\_\_\_\_

2

(c) The tool shown below was used during the manufacture of the bolt.



(i) State the name of this tool.

---

1

(ii) State a reason why this tool was used rather than a pair of outside calipers.

---

1